

Technical Specifications

55489

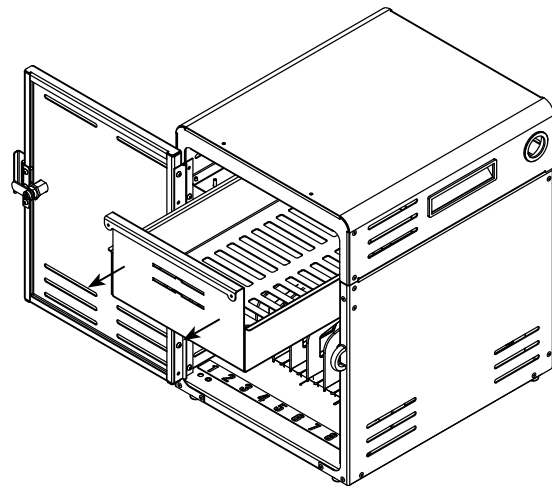
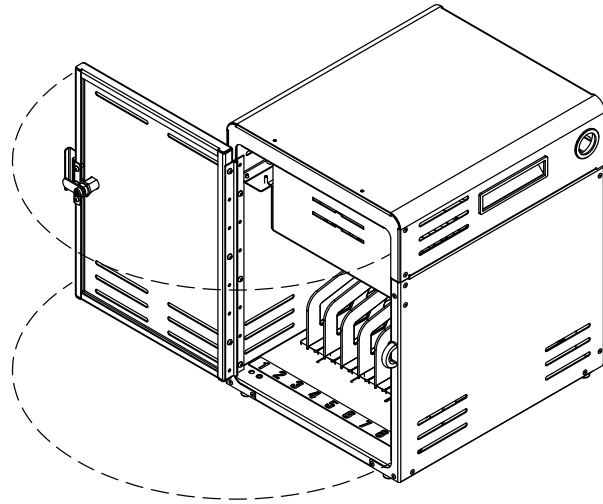
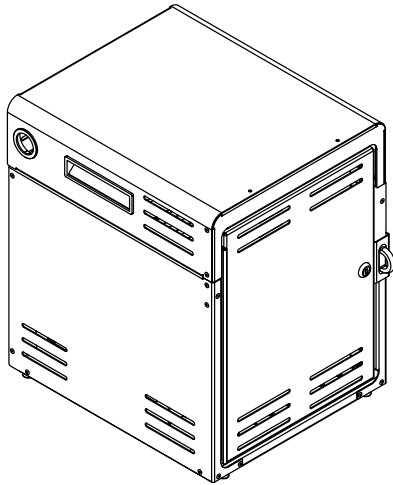

205 Westwood Ave, Long Branch, NJ 07740  
Phone: 866-94 BOARDS (26273) / (732)-222-1511  
Fax: (732)-222-7088 | E-mail: sales@touchboards.com

Use the Connect10 Locker to store and charge up to 10 devices (tablets, Chromebooks™, or notebooks). Flexible dividers protect the computer devices from damage and overhead wire management in a pullout tray aids wiring integration, and allows the charging plugs to hang in front of each device. The Connect10 Locker's small footprint covers less counter space, and is made with powder-coated steel for security and durability. A single-bolt lock, integrated padlock hasp on the door, Kensington® lock capabilities, and surface-mounting all provide additional levels of security.



Features and Benefits

- Stores and charges up to 10 tablets, Chromebooks™, or notebooks
- 1.25"W [3.17 cm] x 14.39"D [36.55 cm] x 10.122"H [25.7 cm] universal storage bay (numbered 1-10)
- Durable ABS plastic dividers (dividers are removable to provide storage space for thicker devices)
- Single point lock, keyed, heavy gauge steel door provides security
- Integrated padlock hasp in the hinged door provides an additional level of security and the ability to use your padlock of choice (not included)
- Unit can be anchored to a floor, permanent worksurface or wall for additional stability and security. (2) #14 x 1-3/4" PHSM screws are provided for anchoring to a wood worksurface or wall stud. (Fasteners for concrete applications not provided)
- Locker can be hung from a wall using optional wall hanging kit
- Multiple lockers can be stacked and secured to each other using optional stacking kit
- Power drawer provides easy-access to electrical power while keeping line voltage, wiring, and cords away from students
- Superior, all-metal overhead cord management system keeps charge cords organized above each storage bay
- Ventilated door and side panels keep devices cool, preventing overheating, and extending device life
- One 10-outlet, surge-suppressed power strip
- Side grommets placed for effective cord management
- Locker ships fully-assembled for quick, simple integration and deployment
- Durable powder coated steel chassis provides a long lasting finish
- Warranted to be free of all defects in materials and workmanship for 10 years, electrical system 2 years
- Designed and assembled in Chippewa Falls, WI, USA

**55489-COO** - Connect10 Locker  
**55489-COU** - Connect10 Locker with 10-outlet power strip

**Color Options**  
Metal:  
Warm Gray 

# Construction

- Metal components consist of 16-gauge steel
- 16-gauge side panels, shelf, drawer, and door
- All metal components are finished with a scratch-resistant powder coat epoxy
- Each Connect10 Locker is factory-assembled

# Specifications

Capacity	10 devices	
Storage bays (nominal)	1.25"W [3.17 cm] x 14.39"D [36.55 cm] x 10.122"H [25.7 cm]	
Power Tray	10.715"W [27.22 cm] x 13.5"D [34.3 cm] x 6.193"H [15.73 cm]	
Electrical (power strip)	<ul style="list-style-type: none"> <li>• Includes one 10-outlet power strip</li> <li>• Outlet type: NEMA 5-15R</li> <li>• 10" [25.4 cm] x 4.75 [12 cm] x 1.5" [3.8 cm]</li> <li>• 125VAC / 15A / 1875W</li> <li>• 10-outlets (8 standard width, and 4 designated transformer outlets) (integrated safety covers)</li> <li>• Surge protection 2850 joules with LED "protected" indicator</li> <li>• LED "grounded" indicator illuminates when a properly grounded AC outlet is detected</li> </ul>	<ul style="list-style-type: none"> <li>• ON / OFF - Reset switch (non-lighted)</li> <li>• Resettable 15-amp circuit breaker</li> <li>• EMI/RFI filtration: 150 kHz to 100 MHz</li> <li>• 8' [244 cm] nominal 3-wire power cord</li> <li>• Right angle power plug with 45-degree offset</li> <li>• Cord gathering bracket</li> <li>• Keyhole mounting slots</li> <li>• Unit weight: 1.9 lb [.86 kg]</li> <li>• Certifications: cUL listed, RoHS</li> </ul>
Certifications / Compliance	<ul style="list-style-type: none"> <li>• TAA compliant</li> </ul>	<ul style="list-style-type: none"> <li>• Meets or exceeds applicable ANSI-BIFMA test standards</li> </ul>
Unit weights (nominal)	40 lb [18.2 kg] - 55489 (no power) 42 lb [19.1 kg] - 55489	
Shipping weights (nominal)	42 lb [19.1 kg] - 55489 (no power) 44 lb [20 kg] - 55489	

Specifications subject to change without notice

10-Outlet power strip

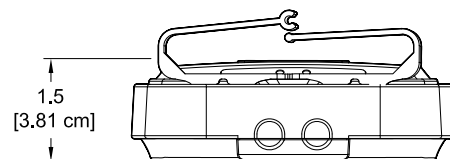
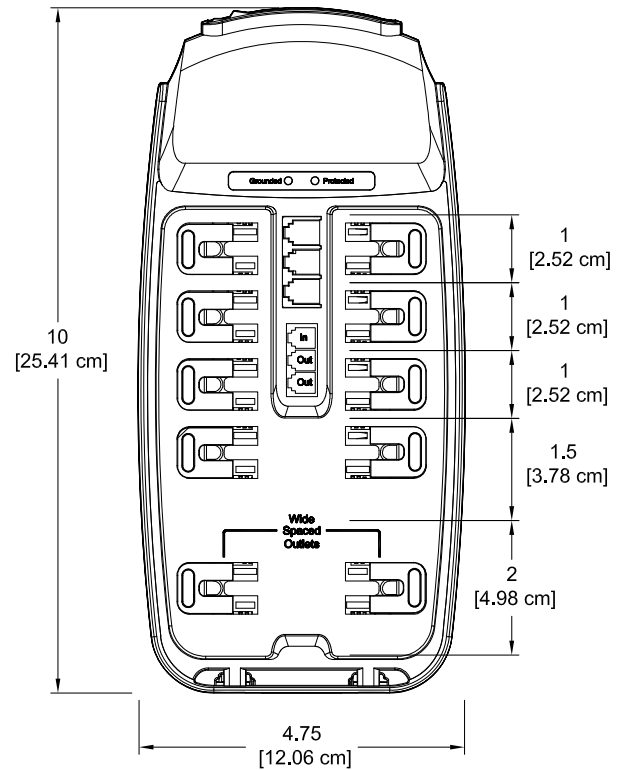

Connect10 Locker

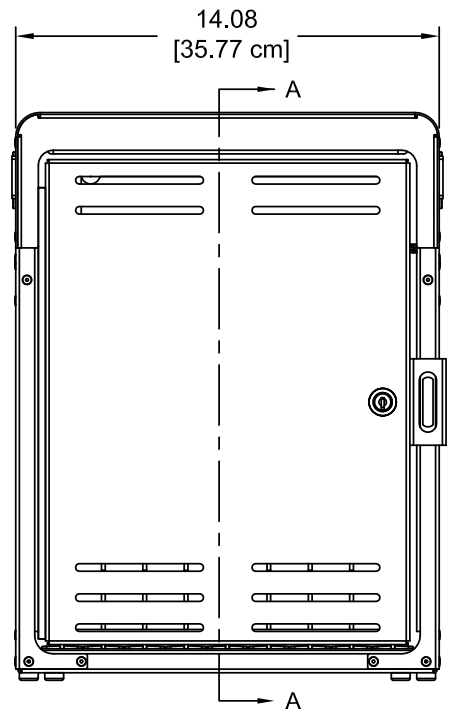
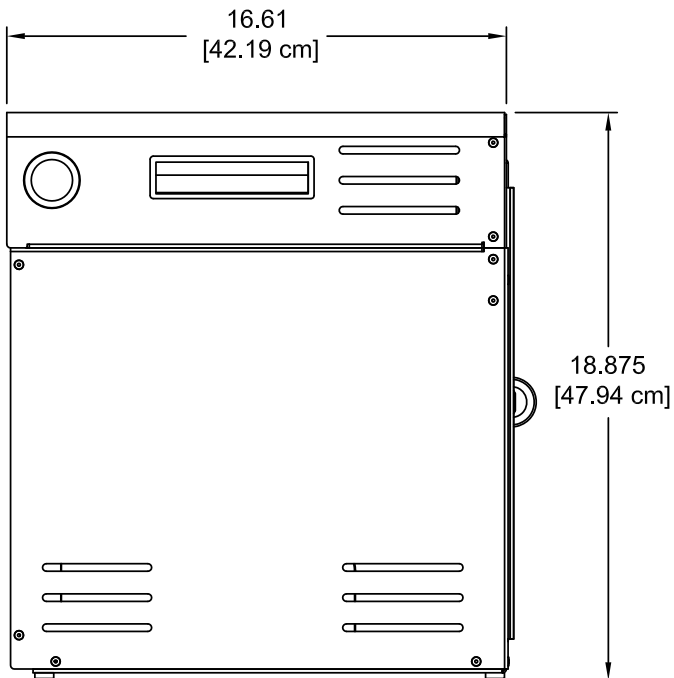
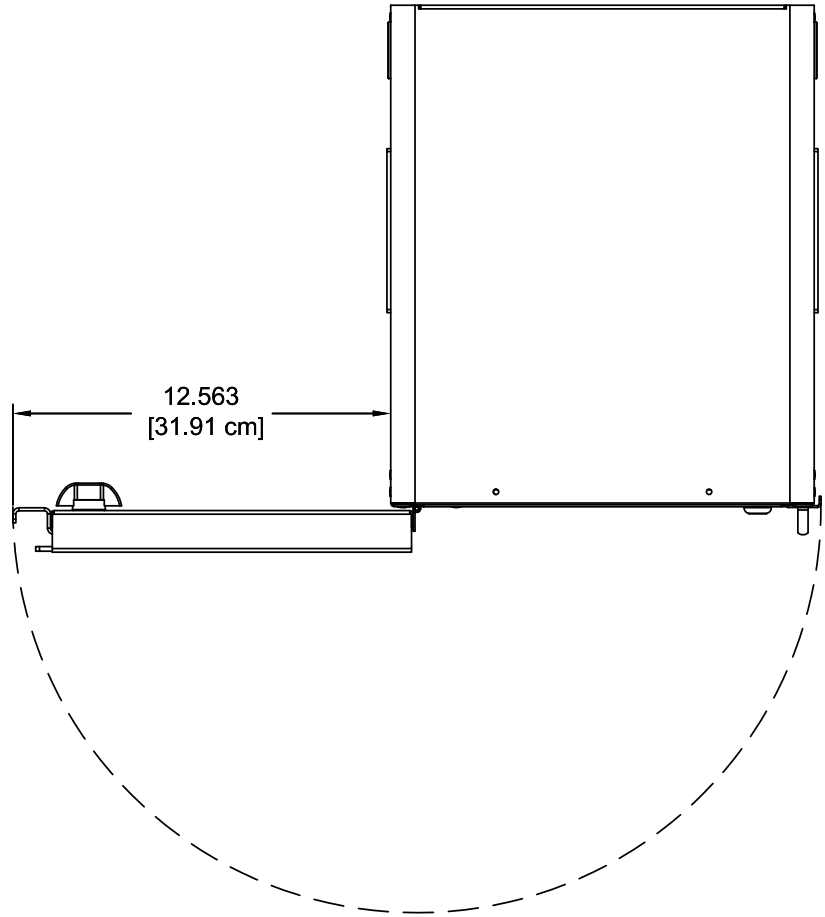
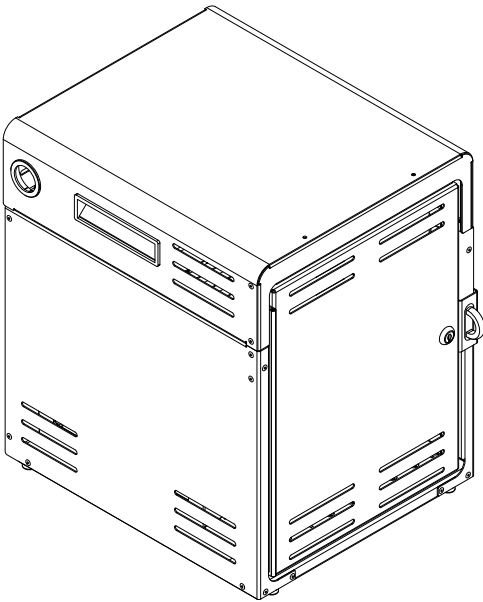

Section View A-A

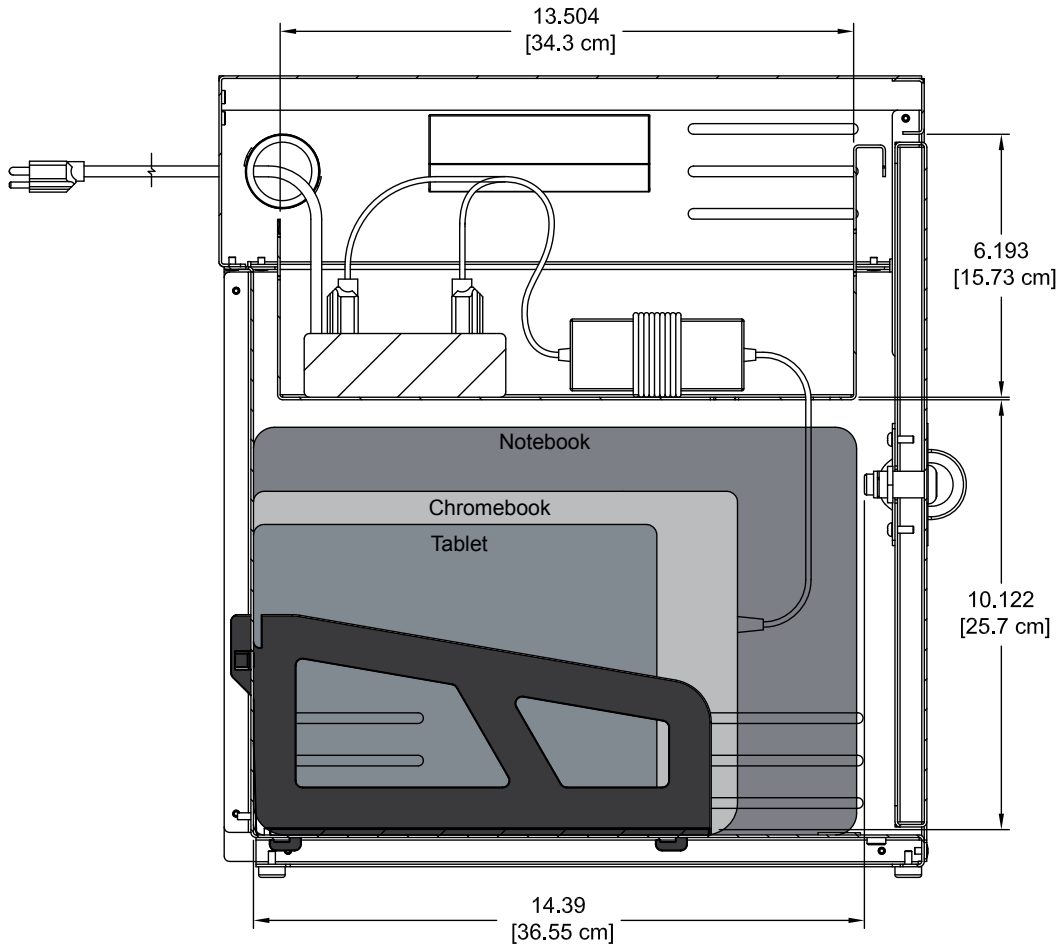

Device-side view with tablets

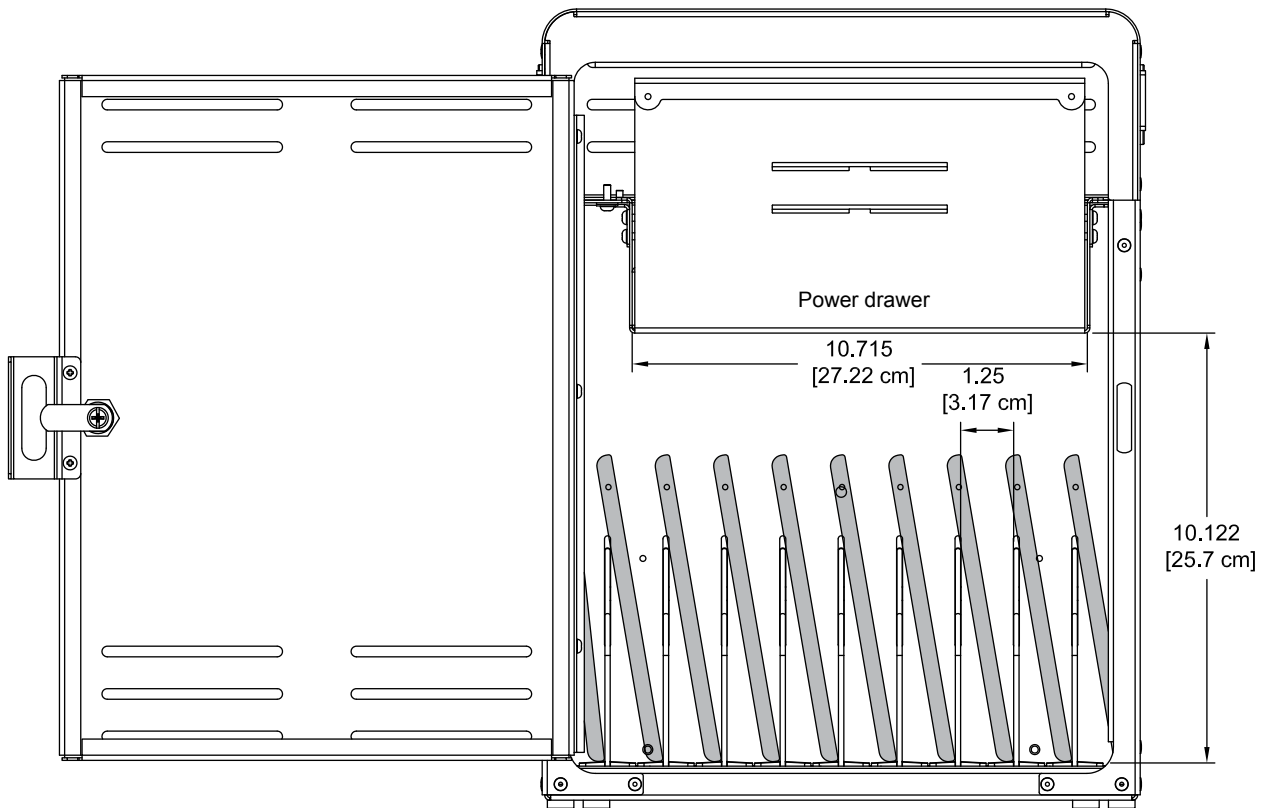

Bottom view of anchor holes

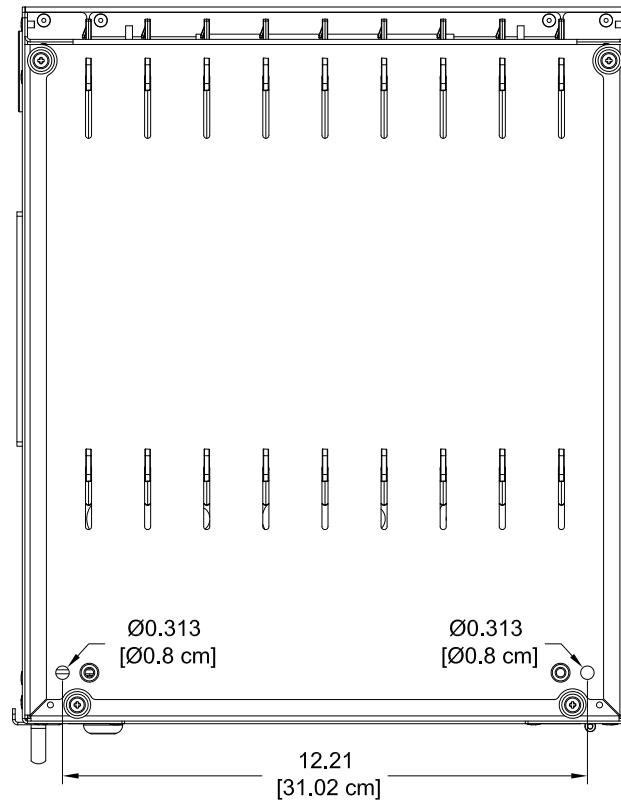

Device-side

## Accessories

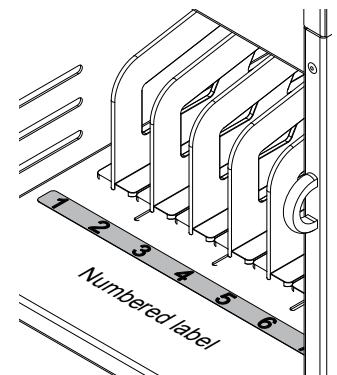
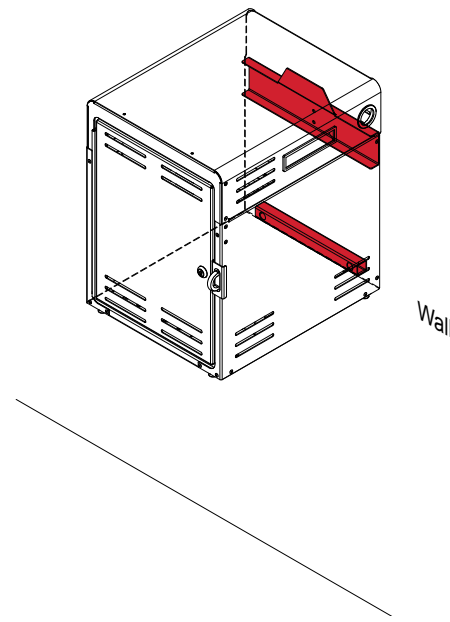
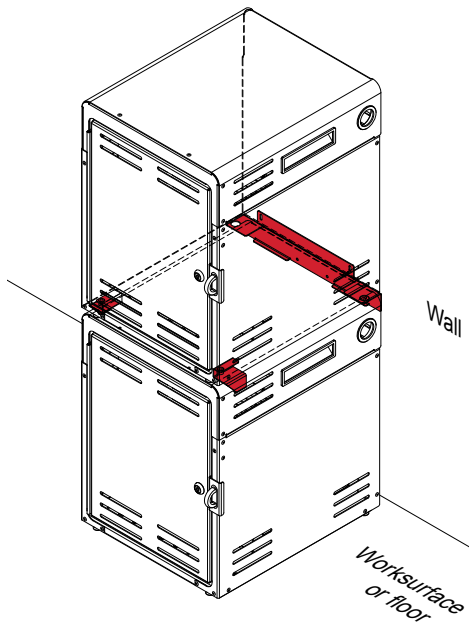

### Stacking Kit - 55491

- Secures to worksurface/floor and wall (Not designed to hang locker from wall)
- One 55491 kit will stack one locker onto another that sits on a worksurface or floor (one kit required for each additional level)
- Max recommended stack height: 2 units (stack of 2 or more must be secured to floor or wall)
- 2 lb [.9 kg]

### Wall Hanging Kit - 55490

- One 55490 kit will attach one locker to a wall
- One 55490 kit required per locker
- Fasteners included for concrete wall applications
- To fully comply with ADA guidelines, it's recommended the locker be hung above base cabinets or other permanent structure that extends to the floor.
- 175 lb [79.5 kg] capacity
- 3 lb [1.4 kg]

### Bay Label Kit - 55492

- Numbered 1-10 label
- Black numbers on transparent adhesive backer

See [spectrumfurniture.com](http://spectrumfurniture.com) for the latest accessories and detailed warranty information.

# Warranty

## **WE WILL MAKE IT RIGHT FOR YOU!**

Spectrum is committed to provide complete customer satisfaction. Each of our products is manufactured from the best materials available and each product is stringently monitored throughout the production process through our P.A.C.E. program (Product Assurance to meet Customer Expectations).

We expressly warrant that Spectrum products will be of good quality and workmanship and free from defect for the period set out in the warranty table below from the date of delivery. This warranty shall not apply to defects or damage resulting from misuse, abuse, neglect, improper care, modification or repair not authorized by Spectrum, or any other cause outside the control of Spectrum. Spectrum will, at its sole option, either repair or replace the defective product.

This warranty is exclusive; no other warranty, written or oral, is expressed or implied. This warranty is given by Spectrum to Buyer and to no other person or legal entity. No Spectrum dealer, distributor, agent or employee is authorized to make any modification or addition to this warranty.

**NOTWITHSTANDING ANYTHING TO THE CONTRARY, SPECTRUM WILL NOT UNDER ANY CIRCUMSTANCES BE LIABLE FOR INDIRECT OR LIQUIDATED DAMAGES, INCLUDING CONSEQUENTIAL, INCIDENTAL AND SPECIAL DAMAGES. IN NO EVENT SHALL SPECTRUM'S LIABILITY, WHETHER UNDER CONTRACT OR WARRANTY, IN TORT OR OTHERWISE, EXCEED THE PURCHASE PRICE RECEIVED BY SPECTRUM FOR THE PRODUCT AT ISSUE AND "RECALL ACTION" EXPENSES. SPECTRUM SHALL NOT BE SUBJECT TO ANY OTHER OBLIGATIONS OR LIABILITIES, WHETHER ARISING OUT OF BREACH OF CONTRACT, WARRANTY, TORT (INCLUDING NEGLIGENCE AND STRICT LIABILITY) OR OTHER THEORIES OF LAW, WITH RESPECT TO PRODUCTS SOLD OR SERVICES RENDERED BY SPECTRUM, OR ANY UNDERTAKINGS, ACTS OR OMISSIONS RELATING THERETO.**

Our Customer Service Department is ready to provide immediate attention to any questions, comments or concerns. They are available to answer your calls Monday through Friday from 7 am to 5 pm CST. In addition your product comments or concerns are welcome via e-mail at: [spectrum@spectrumfurniture.com](mailto:spectrum@spectrumfurniture.com).

Warranty Table

Item	Warranty Period effective 1/1/2015
Adjustable Crank / Electric Desk Legs	• 1 Year
Flat Panel Desk Gas Cylinders	
Chairs <ul style="list-style-type: none"> <li>• Adjustable Height Chair Parts – including frames, gas cylinders, wood and plastic parts, control handles, casters</li> <li>• Adjustable Height Chair Upholstery</li> <li>• In-Stock Upholstery</li> <li>• Graded-In Fabrics and Customer Owned Material</li> </ul>	<ul style="list-style-type: none"> <li>• 7 Years</li> <li>• 2 Years</li> <li>• 2 Years</li> <li>• No Warranty</li> </ul>
Height Adjustable Columns and Lifts	• 1 Year
General Use Casters	
Electrical (including timers and LINAK actuators)	• 2 Years
Keyboard / Mouse Trays	• 1 Year
Flat Panel Monitor Arms <ul style="list-style-type: none"> <li>• Flat Panel Monitor Arm – General Parts</li> <li>• Flat Panel Monitor Arm – Gas Cylinders</li> </ul>	<ul style="list-style-type: none"> <li>• 5 Years</li> <li>• 2 Years</li> </ul>
Desks and Lecterns <ul style="list-style-type: none"> <li>• Computer Desk Chassis</li> <li>• Cart Chassis</li> <li>• Lectern Chassis</li> </ul>	• 10 Years

