

Assembly Instructions

⚠ Important ⚠

Before you begin, read and comply with all safety and operating instructions, and ensure all parts and correct quantities are included.

Any parts damaged during shipment must be reported within 5 days of receipt. To report information regarding missing parts or damage, to purchase parts or accessories, or if you have any questions, please contact us.

www.spectrumfurniture.com
800-235-1262, 715-723-6750

Thank you for purchasing Spectrum products!



(2) 0119468
Recessed bumper
w/ 1/4" washer

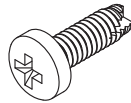

(6) 0100167
8-32 x 1/2" PH
Thread ctg screw

1. Attach door to equipment rack

1. Determine which side of the equipment rack the door will be attached. The locking door is symmetrical and can be mounted to swing from the left or right-side.
2. With the hinge open, align the mounting holes as shown and attach to equipment rack frame with (4) 8-32 x 1/2" PH thread-cutting screws. Be sure the screws are installed straight. Do not tighten completely until all screws are installed. **Figure 1.**

2. Install bumpers

1. With the door open, install each bumper with (1) 8-32 x 1/2" PH thread-cutting screw to the equipment rack frame (opposite of door) as shown. **Figure 2.**

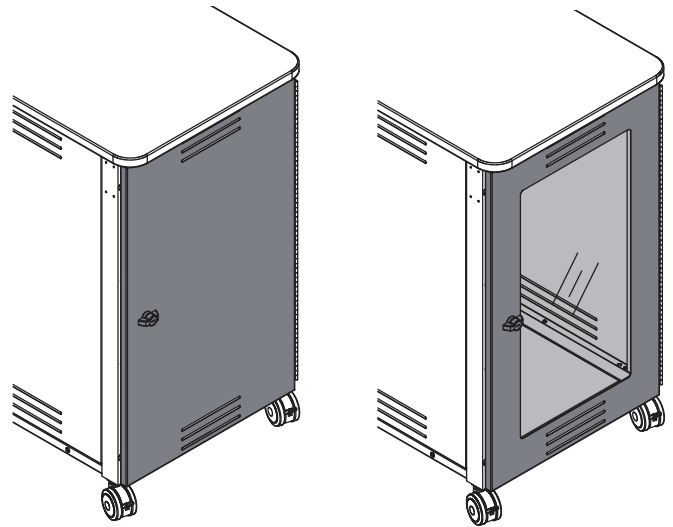

Locking door for Equipment Rack

55509 - 32"H Solid Door
55511 - 39"H Solid Door

55510 - 32"H Acrylic Door
55512 - 39"H Acrylic Door

