

# Assembly Instructions:

To purchase parts or accessories, please contact us at  
[www.spectrumfurniture.com](http://www.spectrumfurniture.com)  
1-800-235-1262  
Thank you for choosing Spectrum products!

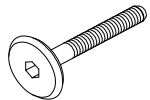

(4) 0102063  
1/4-20 x 35mm JC Bolt

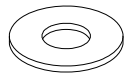

(4) 026059  
1/4" Washer



(4) 037282  
1/4-20 Locknut

Before you begin, please make sure all parts and proper quantities are included. Any parts damaged during shipment must be reported within 15 days of receipt. To report information regarding damages or if you have any questions, please call 1-800-235-1262.

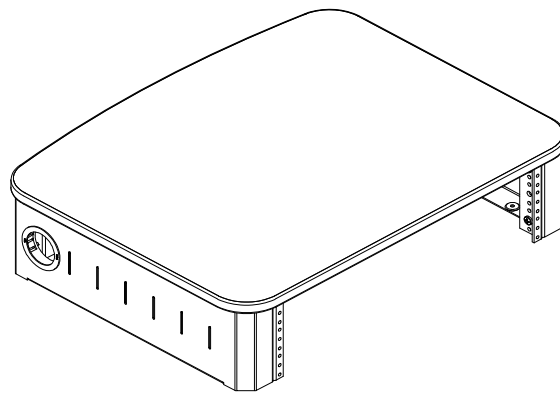

## Overbridge (3RU) #95003

**Tools Required:**  
electric drill  
5/16" drill bit  
7/16" or adjustable wrench  
4mm hex wrench

### 1. Overbridge positioning

**Note:** Some lecterns have pre-drilled overbridge mounting holes under the worksurface. These holes are partially drilled and need to be drilled completely through the worksurface with a 5/16" drill bit to attach the overbridge.

- If your worksurface does not have pre-drilled overbridge mounting holes, place the overbridge on the worksurface in the preferred final mounting location making sure the overbridge and fasteners do not interfere with grommets or anything under the worksurface.
- Mark the (4) mounting hole locations on the worksurface, remove the overbridge, and carefully drill all the way through with a 5/16" drill bit. **Figure 1.**

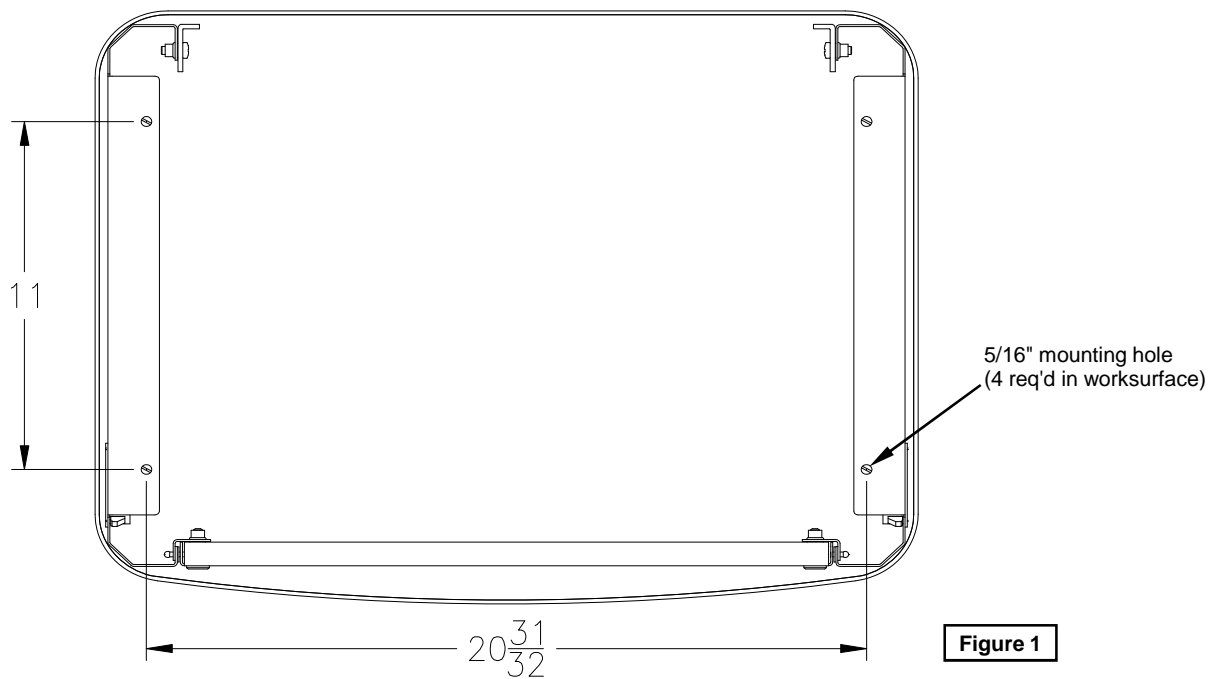

**Caution:** Be sure to use a sharp bit and drill out the worksurface holes slowly to minimize laminate breakage around the holes. Drilling pilot holes and/or placing masking tape on the worksurface laminate at the hole locations before drilling will also minimize breakage.

## 2. Attaching Overbridge

- A. Align the overbridge with the mounting holes. **Figure 2.**
- B. Place a 1/4-20 x 35mm JC Bolt in each hole, followed by a washer and a locknut. **Figure 2A.**
- C. Using a 4mm hex wrench and adjustable wrench, tighten the four bolts securely.

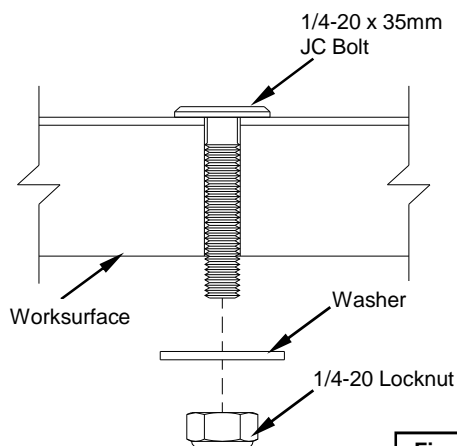
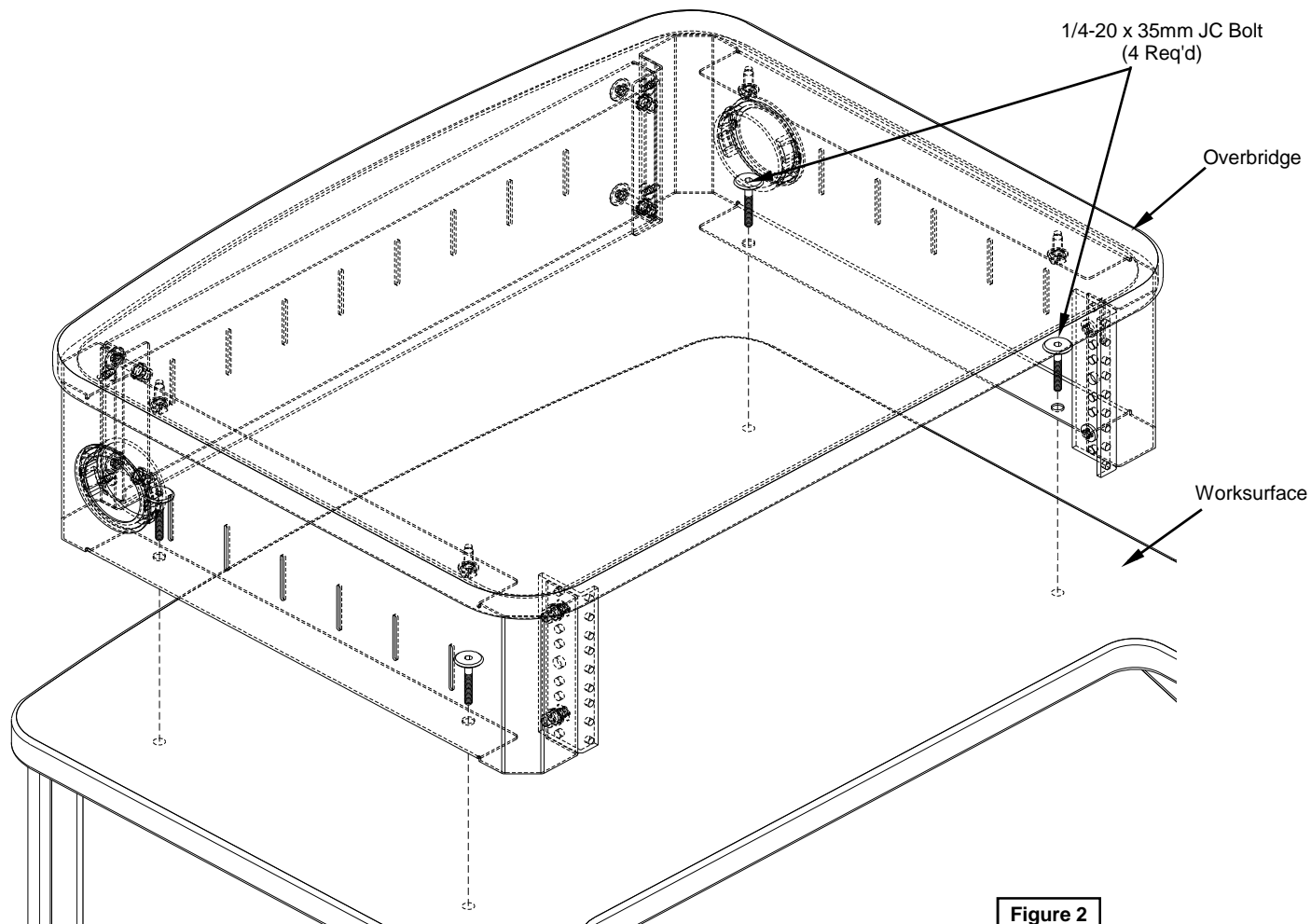

**Touchboards**

205 Westwood Ave, Long Branch, NJ 07740  
Phone: 866-94 BOARDS (26273) / (732)-222-1511  
Fax: (732)-222-7088 | E-mail: sales@touchboards.com

**SPECTRUM**  
INDUSTRIES INC.

925 First Avenue, PO Box 400, Chippewa Falls, WI 54729 Ph: 1-800-235-1262 Fax: 1-800-335-0473  
E-mail: spectrum@spectrumfurniture.com web: www.spectrumfurniture.com