



Assembly Instructions:

SMALL PARTS LIST (per desk)



 1/4-20 X 5/8"
 Pan Head Machine Screw
 (10) #026064 (Black)
 (12) for 48", 60" & 72"
 Desks

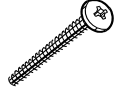

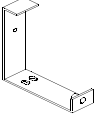
 Glide Wrench
 (1) #025069

 1/4-20 X 1-3/4"
 Pan Head Machine Screw
 (4) #041289 (Silver)

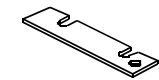

 Chair Rail Bracket
 (1) #051024P
 for 48" 60 & 72" Only

 Glide
 5/16-18 x 1-5/8"
 (4) #025068

 1/4-20 x 2"
 Flat Head Machine Screw
 (2) #043771
 (3) for 48", 60" & 72"
 Desks

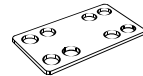

Rear Unit to
 Unit
 Bracket
 (1) #052463



Dual Unit-to-unit
 Bracket
 (1) 036281

TOOLS REQUIRED FOR ASSEMBLY:
 #2 phillips screwdriver

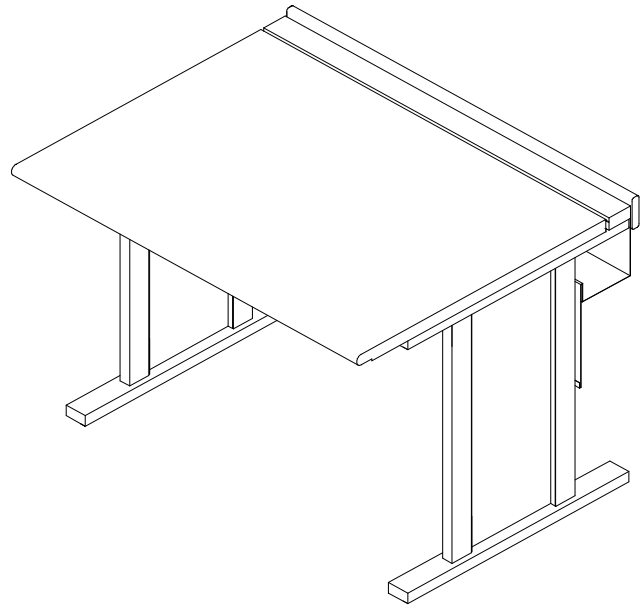

36 - 72 EVOLUTION DESK

Before you begin, please make sure all parts and proper quantities are included. Any parts damaged during shipment must be reported within 15 days of receipt. To report information regarding damages or if you have any questions, please call 1-800-235-

1 ATTACHING LEGS TO WORKSURFACE

A: Position legs, attach with
 4 of the **1-3/4" silver screws**
 (do not tighten screws
 completely at this point).
 See Figure 1.

For 48", 60" & 72" desks only...

B: Attach chair rail bracket
 with 2 of the **5/8" screws**
 (Tighten these screws).

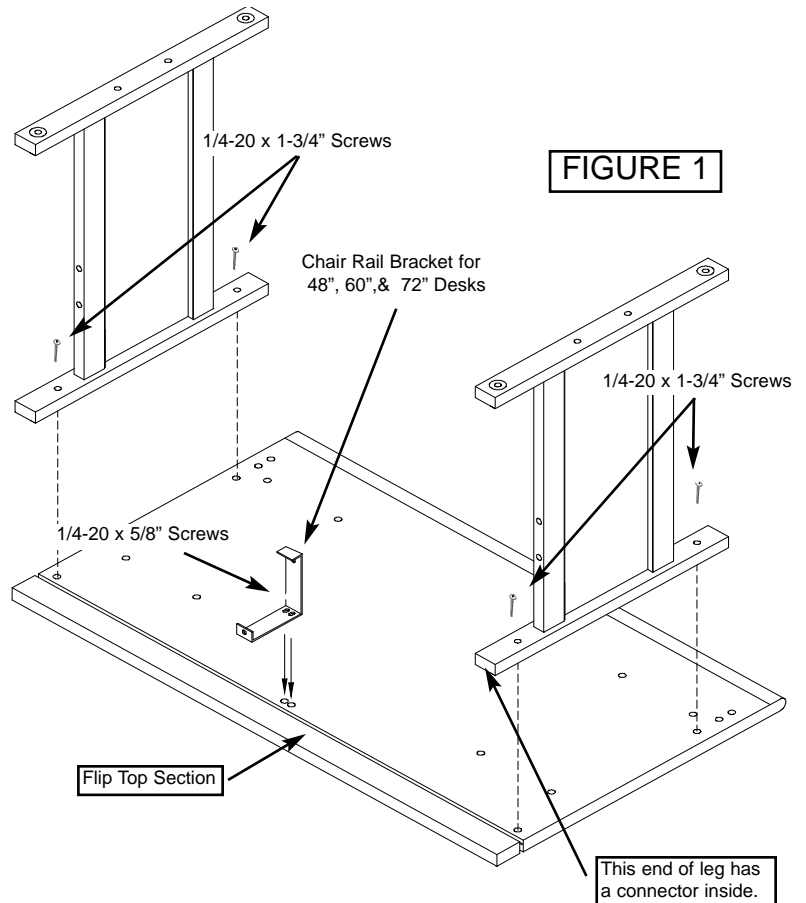

Touchboards

205 Westwood Ave, Long Branch, NJ 07740
 Phone: 866-94 BOARDS (26273) / (732)-222-1511
 Fax: (732)-222-7088 | E-mail: sales@touchboards.com

SPECTRUM
 INDUSTRIES INC.

2 ATTACHING MODESTY PANEL/ CORD CHANNEL TO LEGS

A: Attach Modesty Panel/
Cord Channel to back of legs
as shown in FIGURE 2
with 4 of the **5/8" screws**.

B: Install **glides** in bottom of
leg at this point.

Tighten all screws now.

NOTE: If using chair rail
bracket, slide cord channel
over bracket, then attach to
legs.
Bracket will rest **inside** of
cord channel.

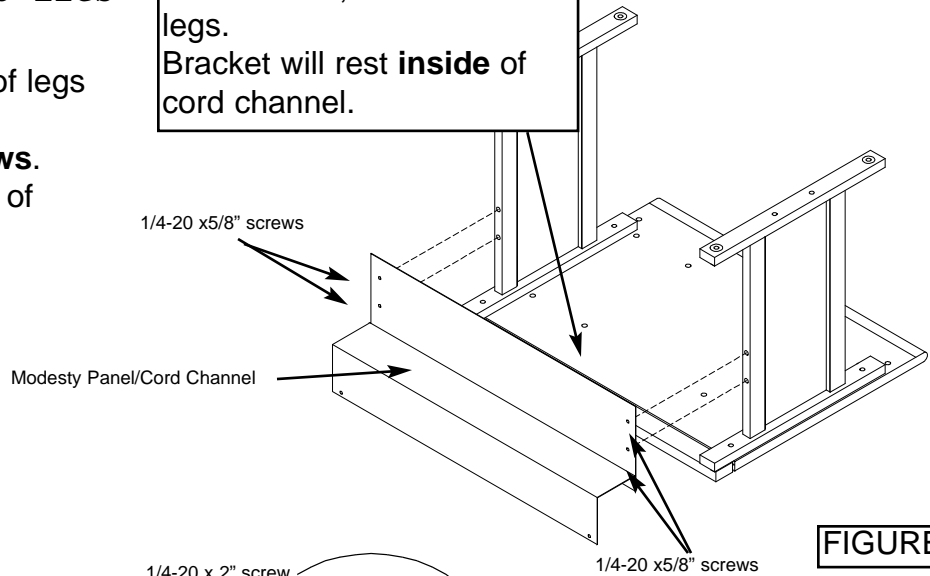

3 ATTACHING CHAIR RAIL

A: Stand desk upright. Attach chair rail
using 2 of the **2" flat head screws** into
the connectors in back of legs (the
countersunk holes are down and out).
See FIGURE 3 & FIGURE 4.

For 48", 60" & 72" desks only...

B: Attach chair rail to **chair rail bracket**
with 1 - **2" flat head screw**.

*(Chair rail bracket may require adjustment
for proper alignment.)*

C: Tighten screws.

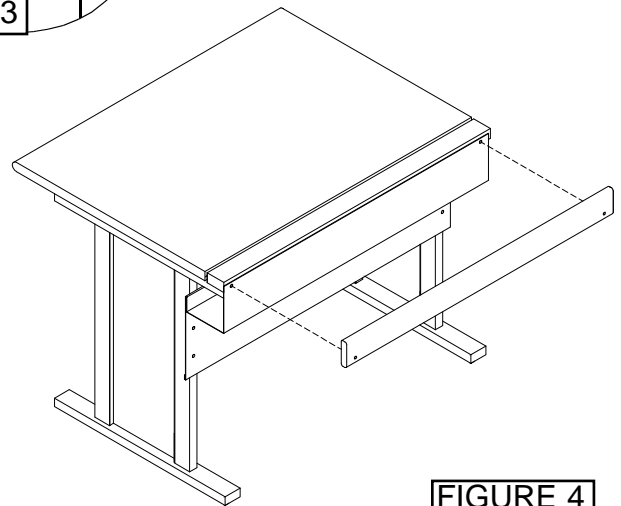
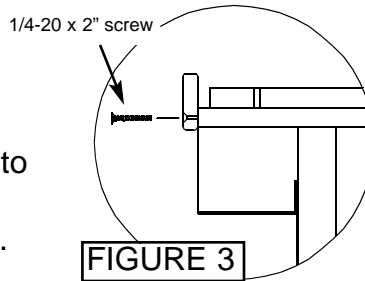

4 ATTACHING DESKS TOGETHER

A: The unit to unit brackets secure one desk
to another, the front side is attached using
4 of the **5/8" screws** for the **dual unit to
unit bracket**. See FIGURE 5.

B. The rear attachment is done by backing out
the leg screw part way and sliding the
rear unit to unit bracket under the
screw head and tighten.
See FIGURE 6.

FIGURE 5

