

Technical Specifications

37125	Table with Set and go™ legs
37126	Table with eLift™ electric legs
37127	Table with Fixed legs

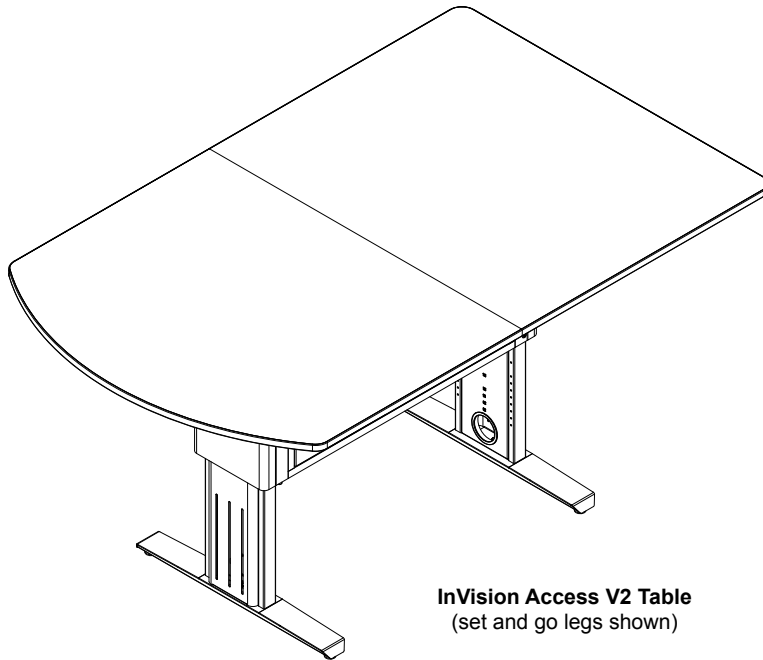

InVision Access V2 Table
(set and go legs shown)

The InVision Access Table is the next generation of active learning classroom and collaboration space furniture. Like the other InVision Collaboration Tables, the Access Table can mount a large screen monitor and has a lot of space for communication and sharing technology securely mounted in the 52" x 84" table. Two different leg options give the user the opportunity to choose the height of the table. The Set and go legs can be assembled to the desired worksurface height from 29 to 42 inches for sitting, standing or any height in between, and the height can be changed in the future if desired. The electric adjustable eLift Legs can be adjusted with a push of a button for on-demand worksurface height adjustment.

Features and Benefits

- The best value in the quickly changing collaboration system environment
- Choose from Set and go (selectable worksurface height during assembly), eLift electric (adjustable-height worksurface), or Fixed leg versions
- Ships with 2 piece cross grain worksurface with matching color edge trim
- Durable powder coated steel chassis provides a long-lasting finish
- Scratch and impact-resistant high-pressure laminate top provides a durable, useful worksurface
- Durable worksurface edge trim
- Heavy-duty braces provide exceptional worksurface support
- Technology compartment / cord channel provides secure internal space for most popular A/V equipment and doubles as a worksurface support to minimize flexing
- ADA-compliant knee clearance under worksurface
- Leveling glides keep table level on uneven surfaces
- Cords and wiring can be channeled cleanly throughout the unit using grommet holes and openings in the bottom of the technology compartment / cord channel
- Removable, ventilated, locking access panels with double-bolt, keyed locks provide security, easy access, and cooling to internal equipment
- Table ships "knocked-down" and can be assembled at the final location for easy installation and lower shipping costs
- Optional display stand provides ability to attach most monitors (37"-63" diagonal)
- SCS Indoor Advantage Certified; meets or exceeds applicable ANSI-BIFMA test standards
- Warranted to be free of all defects in materials and workmanship for 10 years, electrical system 2 years
- Manufactured in Chippewa Falls, WI, USA



205 Westwood Ave, Long Branch, NJ 07740
Phone: 866-94 BOARDS (26273) / (732)-222-1511
Fax: (732)-222-7088 | E-mail: sales@touchboards.com



Color Options

Standard laminate / metal color combinations	3mm vinyl worksurface edgeband color
Wild Cherry / Black (CHB)	Wild Cherry
Fusion Maple / Black (FMB)	Fusion Maple
Fusion Maple / Silver Sparkle (FMS)	Fusion Maple
Indigo Organix / Black (IB)	Black
Indigo Organix / Silver Sparkle (IS)	Black
White Fiesta / Black (WFB)	Black
White Fiesta / Silver Sparkle (WFS)	Silver

Standard color combination refers to the quickest deliverable product color combination. Custom laminates and color combinations are available-additional lead-times and up-charges may apply. Call 1-800-235-1262 for further information.

Construction

- The worksurfaces are constructed from 1.063" thick NAUF (No Added Urea Formaldehyde) composite board with .030" high-pressure laminate on one face, and a balancing phenolic backer on the opposing face
- Metal components consist of 12, 16, and 20-gauge steel
- The formed worksurface braces are 14-gauge steel
- Worksurface edges are covered with 3mm vinyl (color matching)
- All metal components are finished with a scratch-resistant powder coat epoxy
- Tables are shipped KD (Knocked-Down) and require assembly

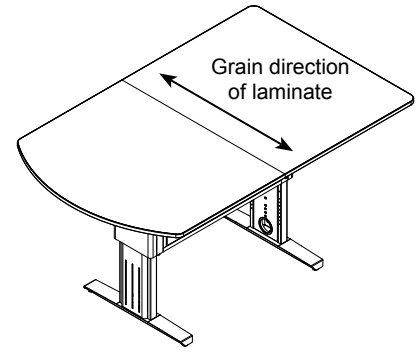

Specifications

Worksurface height adjustability	<ul style="list-style-type: none"> • Set and go legs - 29-42"H [73.66-106.68 cm] in 1" and 2" increments (<i>adjustable at time of assembly</i>) (height settings available: 29", 30", 31", 32", 34", 36", 40", 42") • eLift electric legs - 29-42"H [73.66-106.68 cm] • Fixed legs - 29"H [73.66 cm]
Available worksurface cutout area	<ul style="list-style-type: none"> • 37.625"W [93.98 cm] x 10"D [25.4 cm] (Fixed and Set and go legs) • 27.188"W [69 cm] x 10"D [25.4 cm] (eLift electric legs)
Internal area of cord channel (nominal)	35.625"W [90.5 cm] x 9.875"D [25 cm] x 13.938"H [35.4 cm]
Seating	See configuration possibilities on p.6
ADA-compliance*	Each table supports (4) ADA-compliant seating positions
	<p><i>*Minimum ADA guidelines for knee clearances are 30"W [76.2 cm] x 19"D [48.3 cm] x 27"H [68.6 cm]</i></p> 
eLift electric legs	<ul style="list-style-type: none"> • Full range of motion: 13" [33 cm] in approximately 10 seconds • Inverter: 120V @ 60Hz, max output 400 watts • Motors: 18V / 10 amps • Typical electrical load during operation: <u>4.3 amps @ 120 VAC</u> • Anti-collision protection • 11' [335 cm] nominal 3-wire power cord • Max load: 800N (180 lb) [81.7 kg] per actuator (total lift capacity: 360 lb [163.4 kg]) • Actuators feature non-hydraulic, permanently lubricated screw jacks • Actuators rated for 20,000 cycles
Shipping dimensions (nominal)	52"W x 84"D x 42"H - 37125 - (Set and go) 52"W x 84"D x 42"H - 37126 - (eLift table) 52"W x 84"D x 29"H - 37127 - (Fixed table)
Shipping weights (nominal)	306 lb [139 kg] - 37125 - (Set and go) 350 lb [159 kg] - 37126 - (eLift) 290 lb [132 kg] - 37127 - (Fixed legs)

Specifications subject to change without notice

Leg options

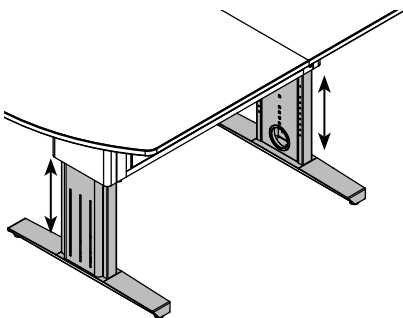

Set and go
(29-42"H)
[73.7-106.7 cm]

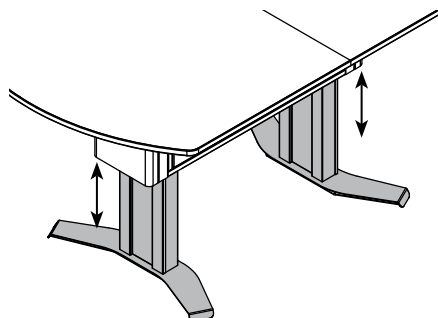

eLift electric
adjustable-height
(29-42"H)
[73.7-106.7 cm]

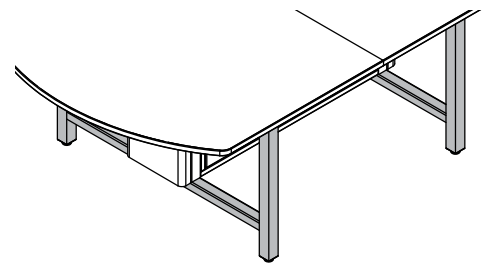

Fixed
(29"H)
[73.7 cm]

InVision Access V2 Table
with Set and go legs

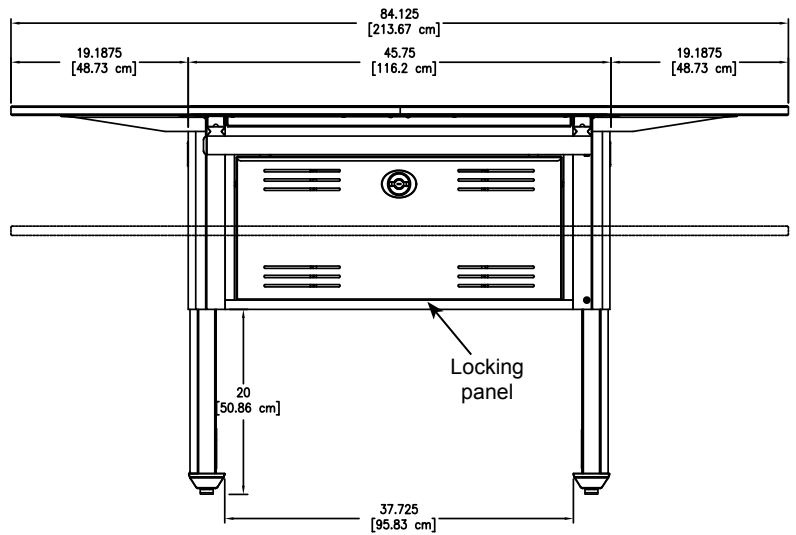
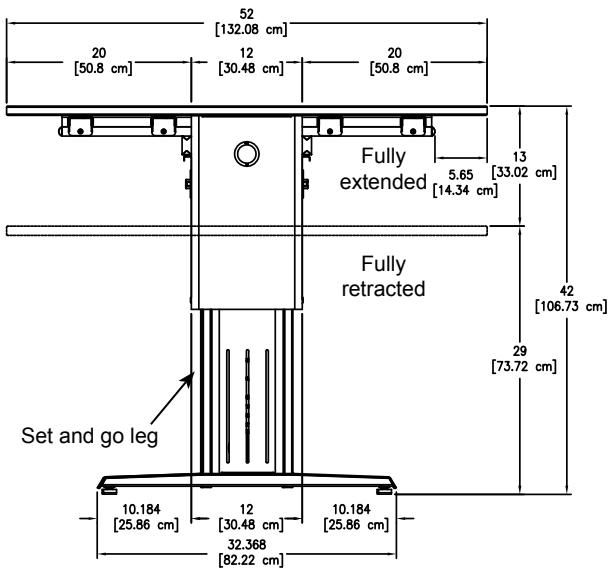
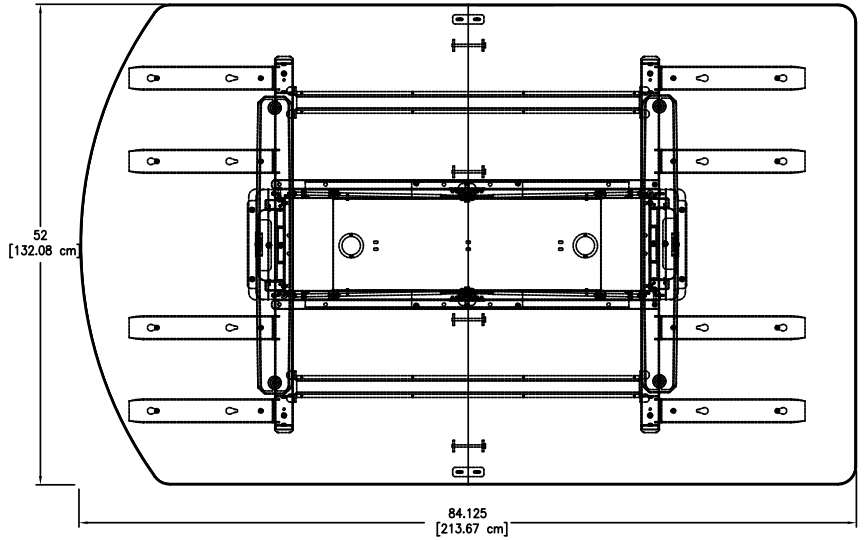
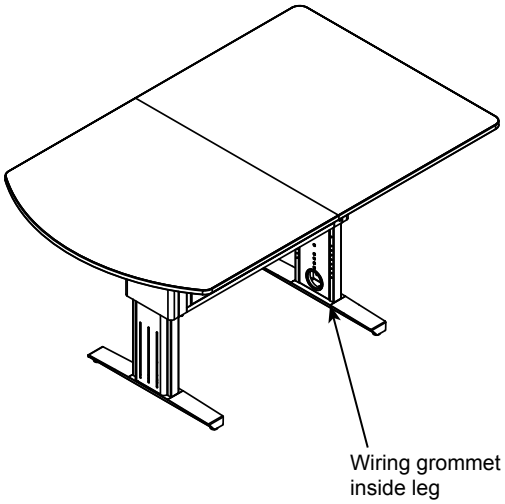

Note: The InVision Access Table does not support optional keyboard trays.

InVision Access V2 Table
with eLift electric legs

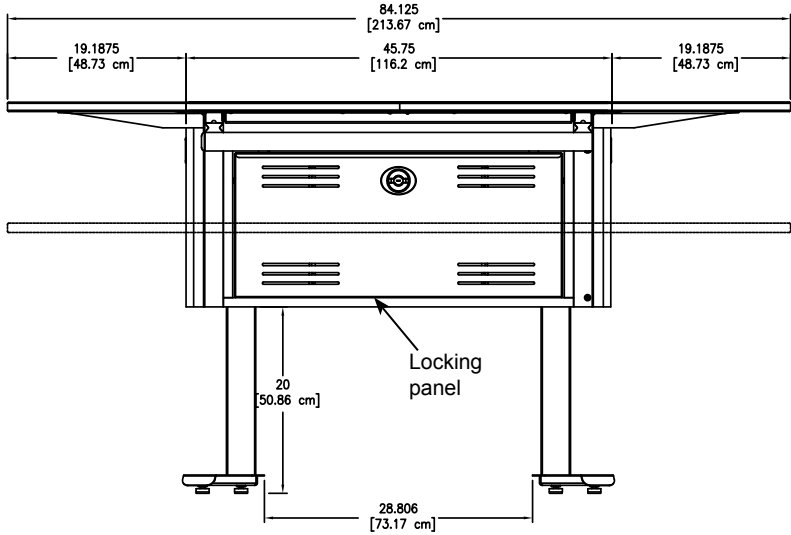
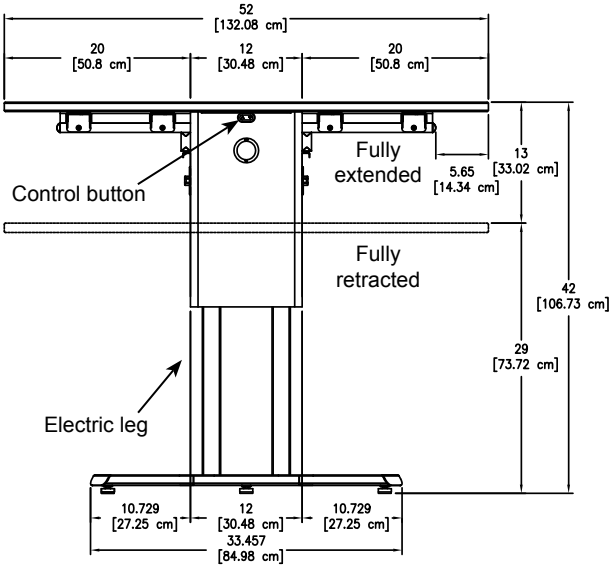
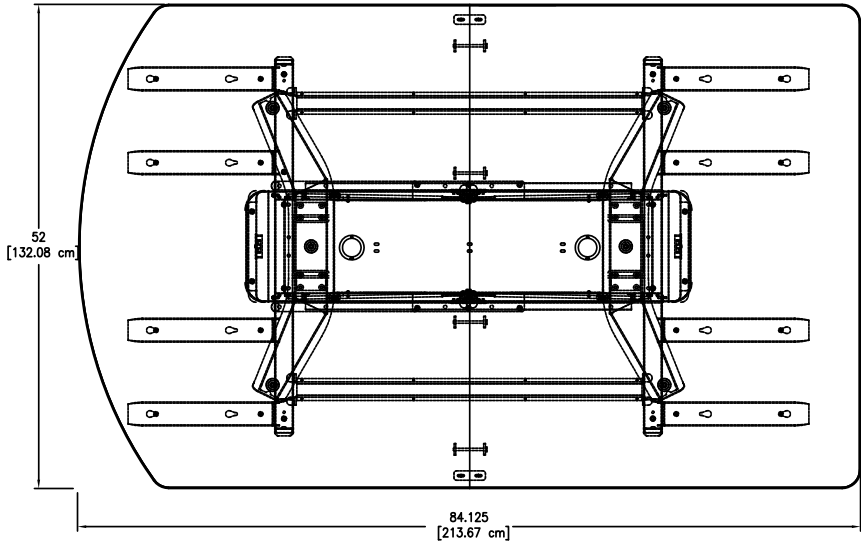
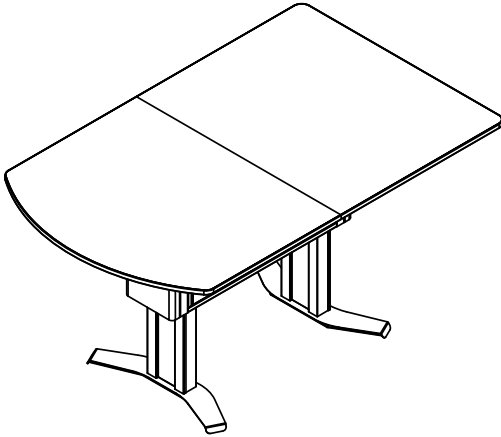

Note: Includes user-mountable control button.

Note: The InVision Access Table does not support optional keyboard trays.

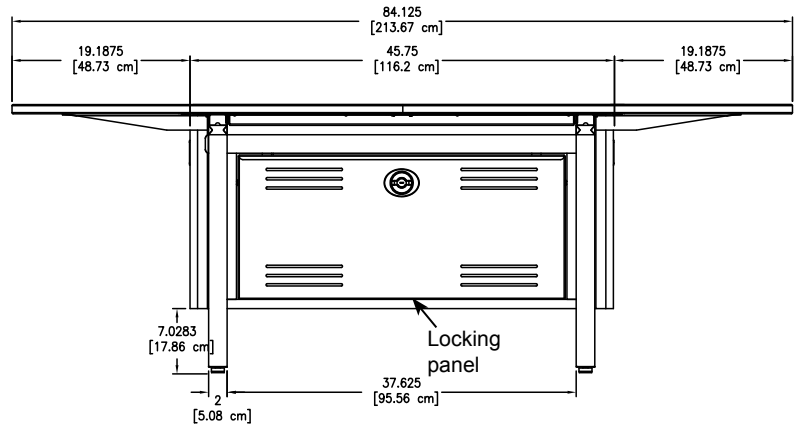
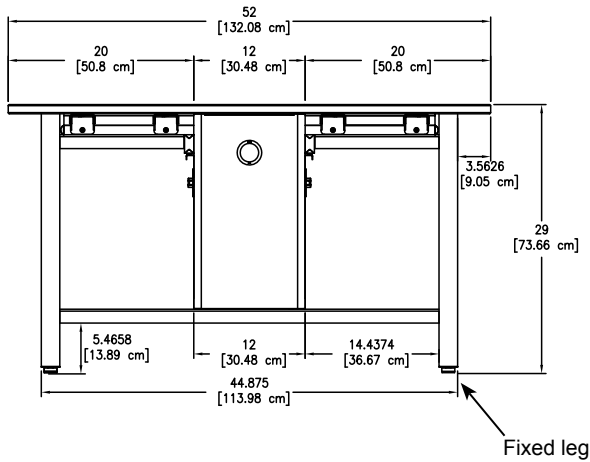
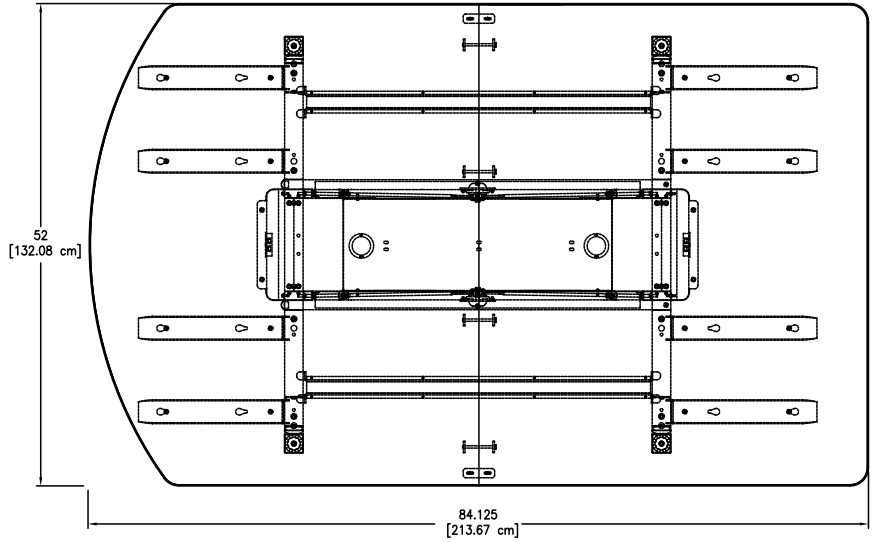
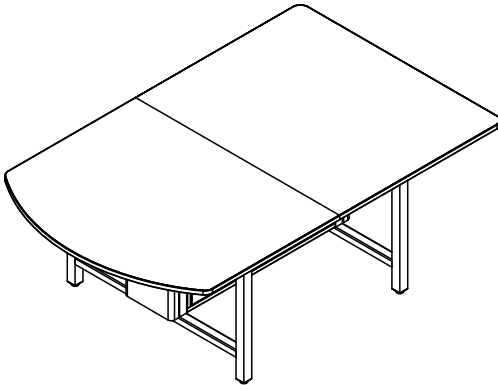

Note: The InVision Access Table does not support optional keyboard trays.

Possible seating configurations
 InVision Access V2 Table
 (Set and go and eLift electric legs)

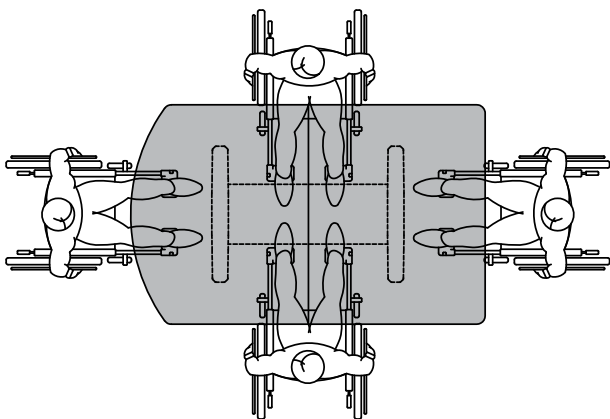
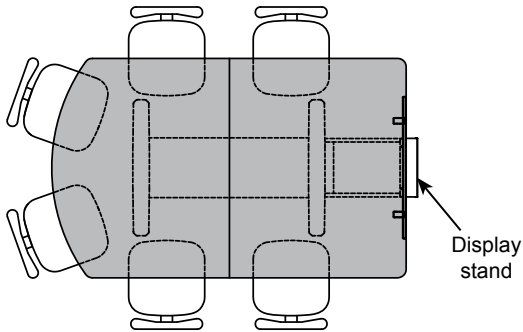
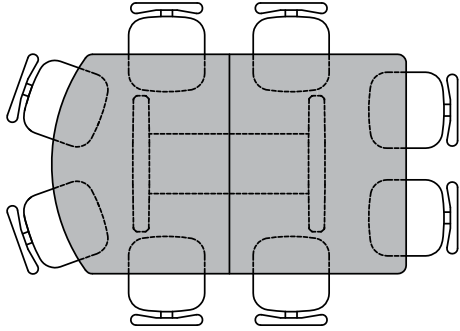

Possible seating configurations
 InVision Access V2 Table
 (Fixed legs)

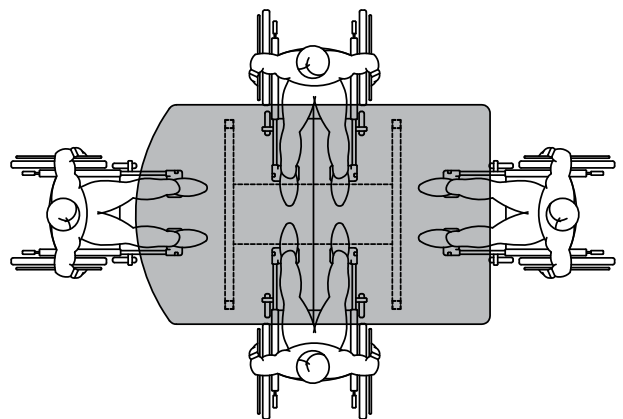
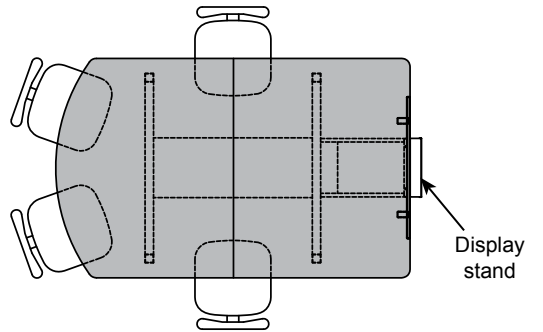
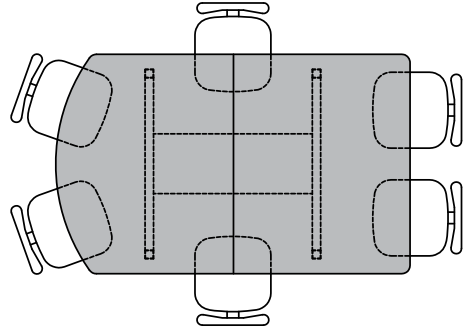

Note: The 2 piece worksurface can be ordered blank or with cutouts. The table has been designed for many of the currently available surface-mount devices on the market.

***When ordering a table with cutouts, specify complete details of the device(s) (brand, model number, cutout size, quantity, etc.) to the Spectrum sales rep when ordering.**



Note: Some controllers and devices require additional space around the cutout for clamping under the worksurface. Please double check your device specifications to ensure adequate space around the cutout.

Note: Spectrum Industries, Inc, manufactures furniture that supports a wide variety of power and communication devices from a variety of manufacturers. The InVision Access table is compatible with many Extron, Crestron, Altinex, AMX, and other devices. Spectrum does not resell these products; *please consult your electronic supplier* for the equipment that best suits your needs. Size specifications from the manufacturer can be used to verify the fit.

InVision Access V2 Table
available worksurface cutout
area in 2 piece worksurface

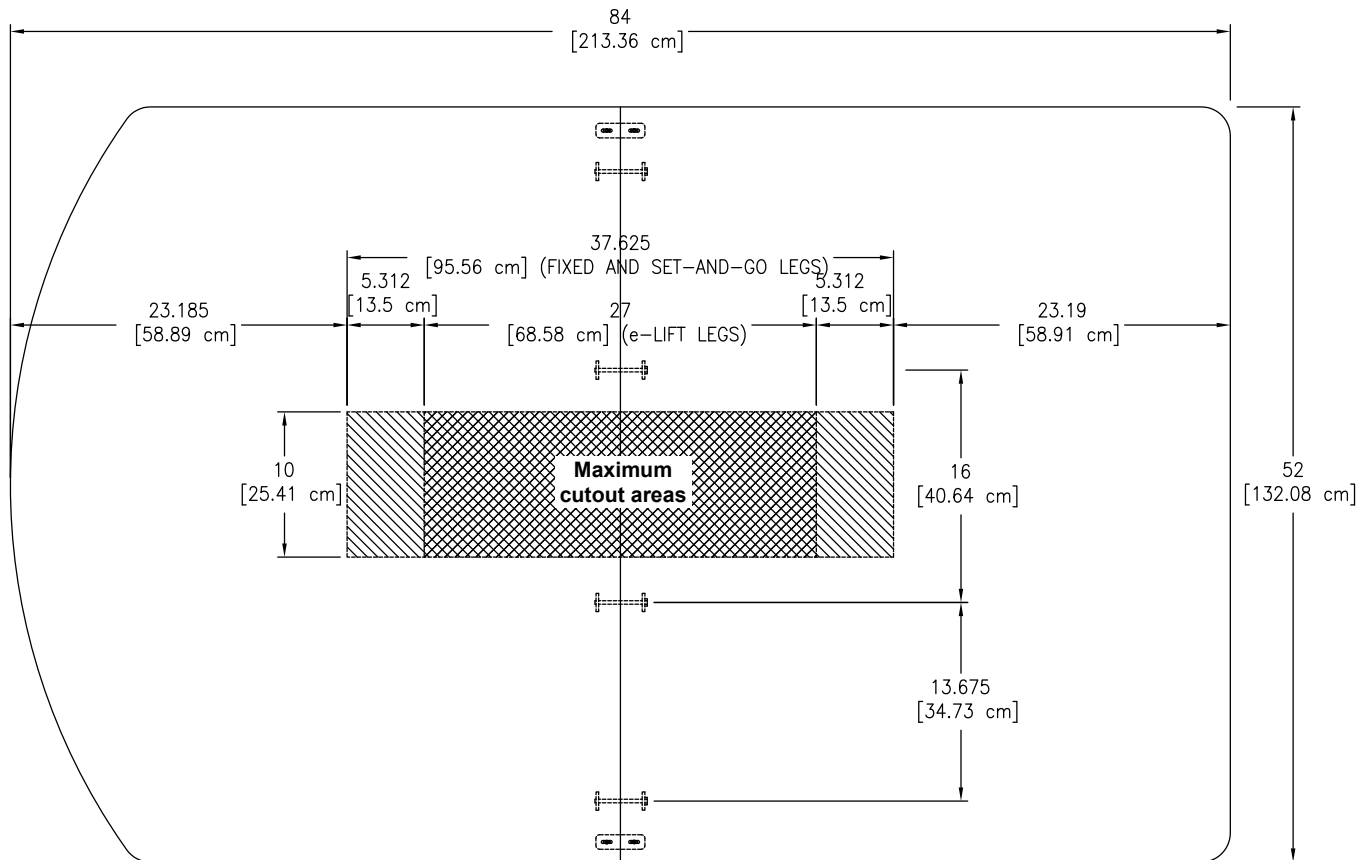

Custom cutouts by Spectrum

2 cutouts are provided at no charge. Spectrum can provide cutouts exactly matching any commercially available data and electrical power outlet, but are only recommended within the maximum cutout areas shown. Cutouts made beyond this shaded area could interfere with the legs, cord channel rails, or worksurface reinforcement bars.

Cutouts in standard (blank) worksurfaces by customer

Cutouts in standard (blank) worksurfaces can be made by the customer after the table has been assembled, but are only recommended within the maximum cutout areas shown. Cutouts made beyond this shaded area could interfere with the legs, cord channel rails, or worksurface reinforcement bars. Before assembling the worksurface and locating the cutouts, consideration should be given to avoid the draw bolts along the worksurface seam. See draw bolt location dimensions.

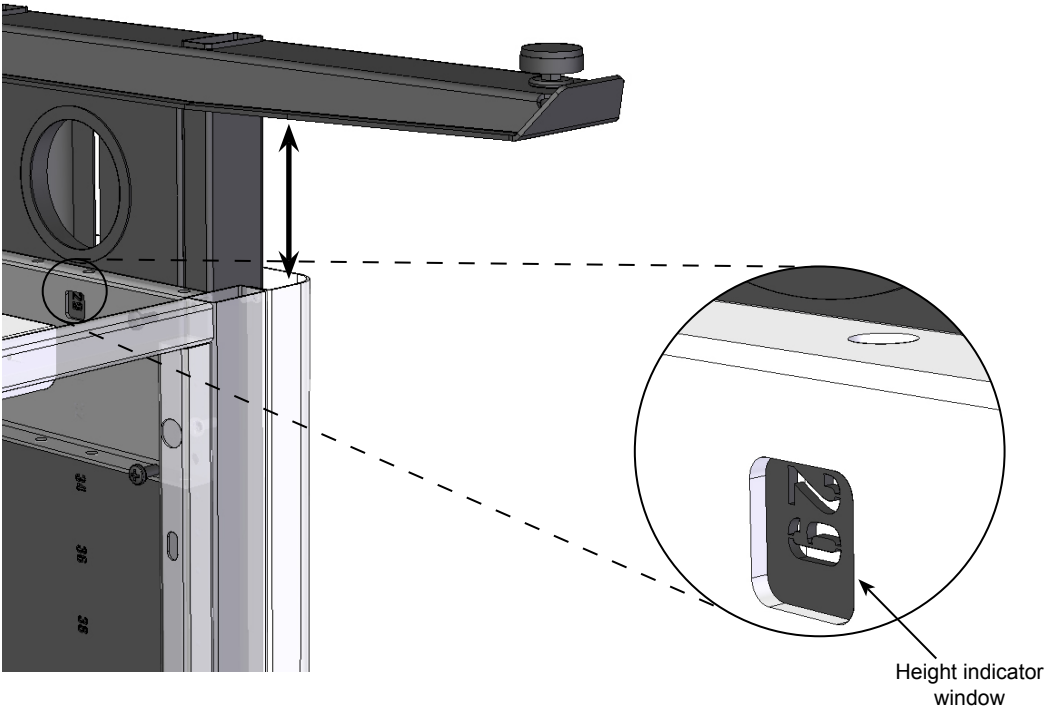

Section view
(Set and go leg shown)

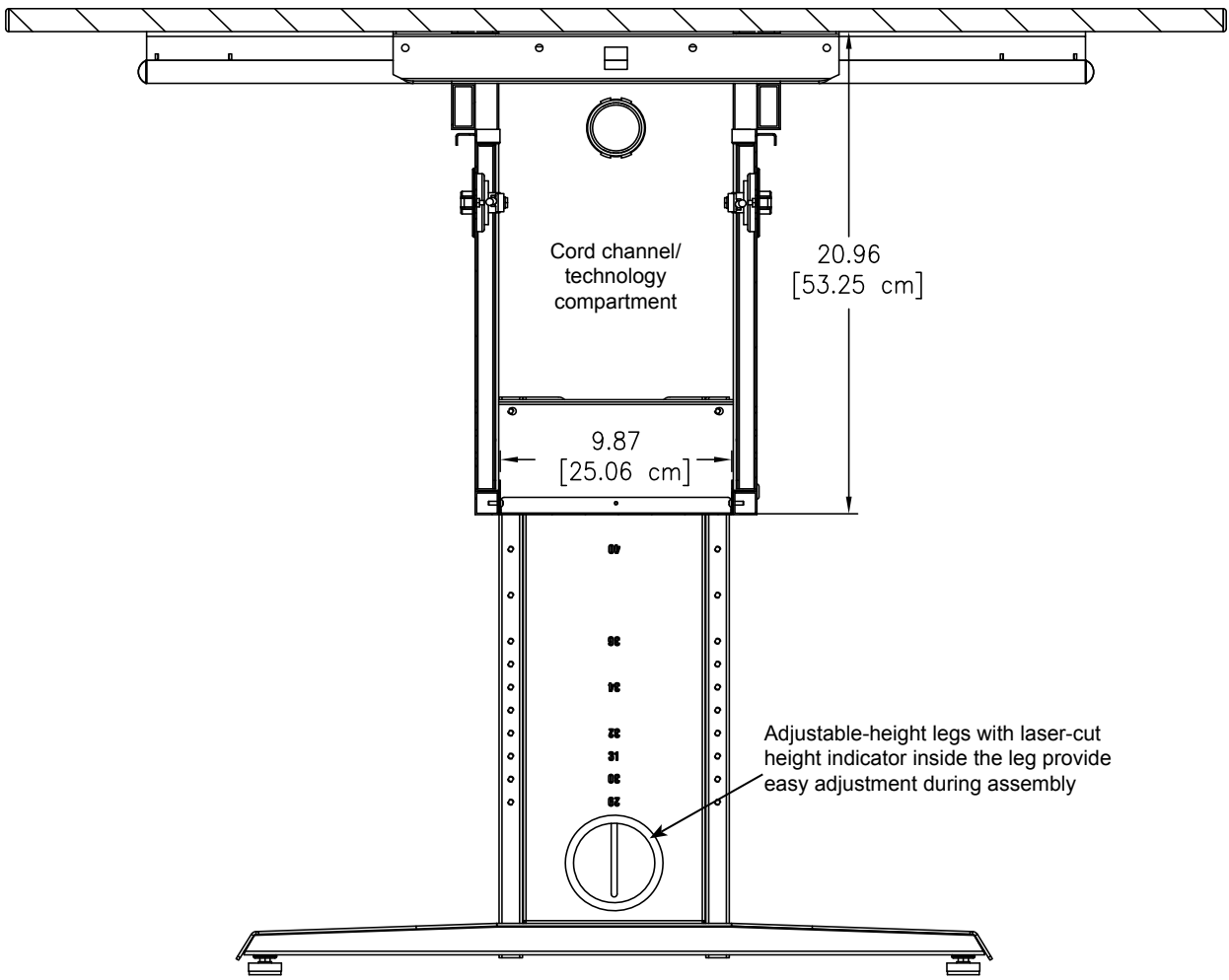

Options

Access Display Stand - 37120

- Includes two-position VESA display mount with tilting mounting brackets
- Wiring channel and back panel provide secure and hidden wiring to technology compartment
- Laminate panel matches table color and can be drilled to support other custom monitor mounts

Monitor size range	37"-63" [94-160 cm] diagonal
Max weight capacity	100 lb [45.4 kg] <i>(see chart below for combination capacities)</i>
Tilting	15° range
Available colors	CHB, FMB, FMS, IB, IS, WFB, WFS
Box dimensions (nominal)	42" [106.7 cm] x 31.25" [79.4 cm] x 5.5" [14 cm]
Weight (nominal)	47 lb [21.34 kg]

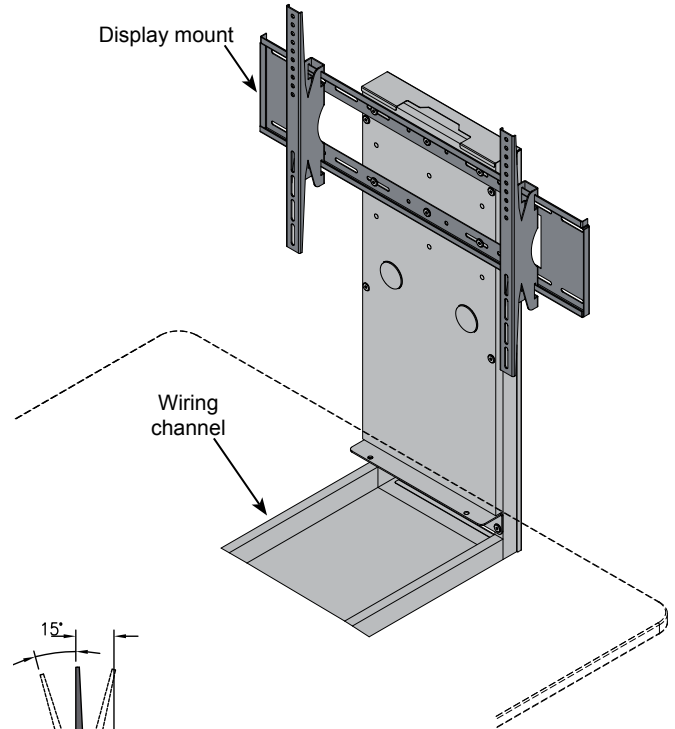

Two-vertical positions available
(dimensions shown to center of mount)

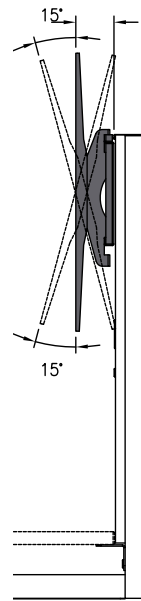
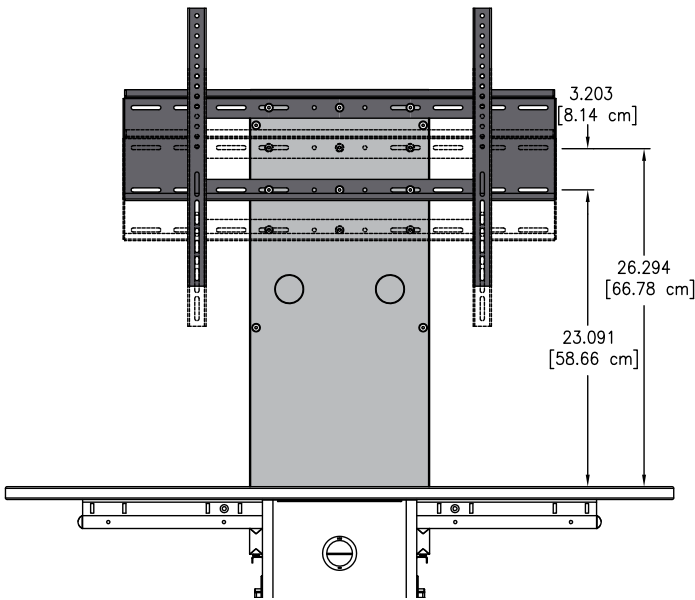

	Added InVision Access option			Weight capacity available for installed monitor(s)
	Display Shroud 95532 -38 lb -[17.3 kg]	Dual Display Mount 37124 -29 lb -[13.2 kg]	Camera Mount 37108 -7 lb -[3.18 kg]	
InVision Access Display Stand 37120 100 lb [254 kg] capacity			✓	= 93 lb [42.2 kg]
	✓			= 62 lb [28.1 kg]
	✓		✓	= 55 lb [25 kg]
		✓		= 71 lb [32.2 kg]
		✓	✓	= 64 lb [29 kg]
	No additional options added			= 100 lb [45.4 kg]

*Note: The display shroud is not compatible with the dual display mount.

InVision Access Display Shroud - 95532

- Helps project sound from rear monitor speakers to audience
- Protects monitor and hides wires
- Adjustable width
- Upper and lower height mounting options
- Made of aluminum
- Requires Access Display Stand 37120

Monitor size range	for one 37"-63" [94-160 cm] monitor
Available colors	B, S
Box dimensions (nominal)	N/A
Weight (nominal)	38 lb [17.25 kg]

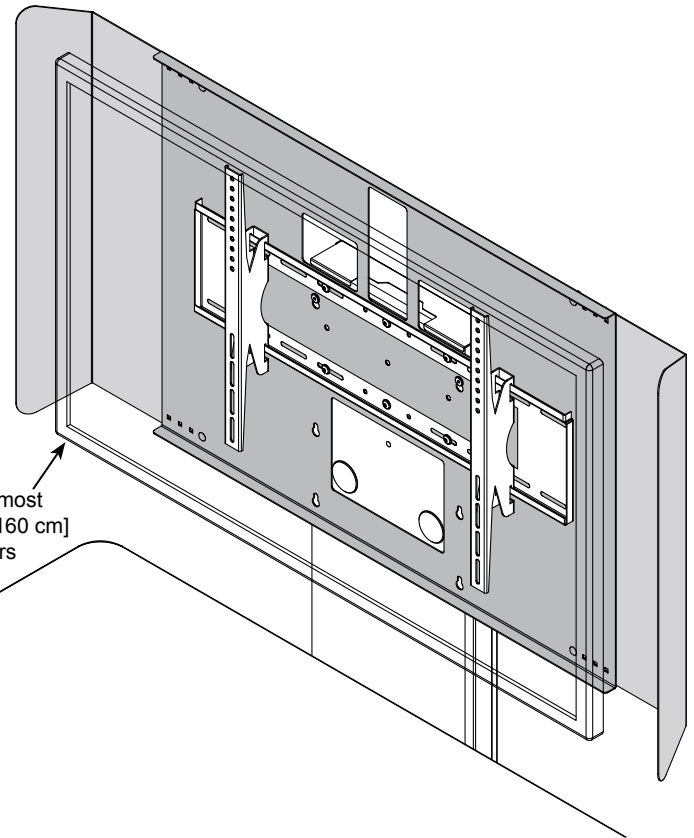
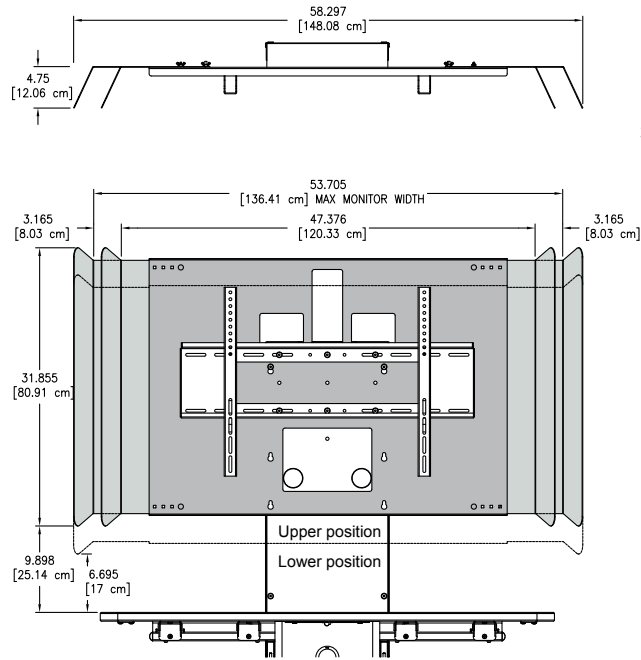

Note: The Display Shroud is not compatible with the Dual Display Mount.

Camera Mount - 37108

- Provides ability to mount camera for video teleconferencing
- Requires Access Display Stand 37120
- Mounts above monitor for group teleconferencing
- Adjustable height bracket provides shelf height adjustment
- Includes two shelf sizes to accommodate most camera and video devices
- Not recommended for use with the dual display mount

Shelf sizes included	12"W [30.5 cm] x 8.5"D [21.6 cm] and 6.5"W [16.5 cm] x 8.5"D [21.6 cm]
Available colors	B, S
Box dimensions (nominal)	14" [35.6 cm] x 9" [22.9 cm] x 3.5" [8.9 cm]
Weight (nominal)	7 lb [3.2 kg]

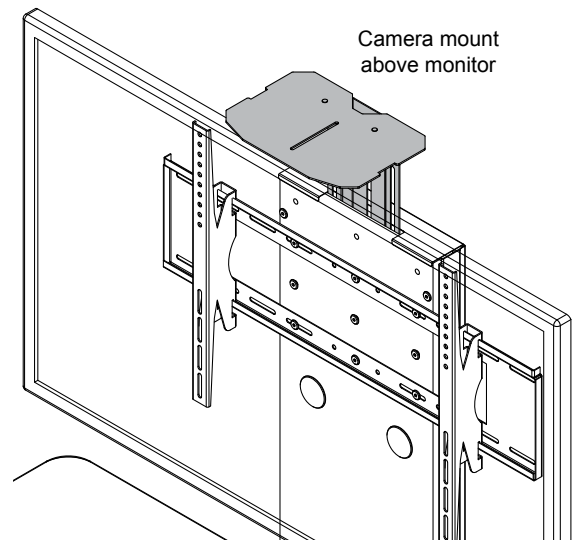
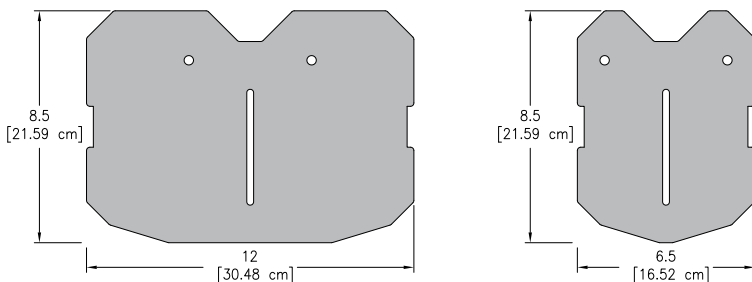

Note: To mount the Camera Mount, the monitor mount must be attached to the Display Stand in the lower position.

InVision Access Dual Display Mount - 37124

- For two monitors up to 42" [106.7 cm]
- Includes a 2nd two-position VESA display mount with tilting mounting brackets
- Includes 2 support tubes
- Adjustable left-to-right
- Requires Access Display Stand 37120

Monitor size range	Most monitors up to 42" [107 cm] diagonal
Tilting	15° range
Available colors	B
Box dimensions (nominal)	N/A
Weight (nominal)	29 lb [13.166 kg]

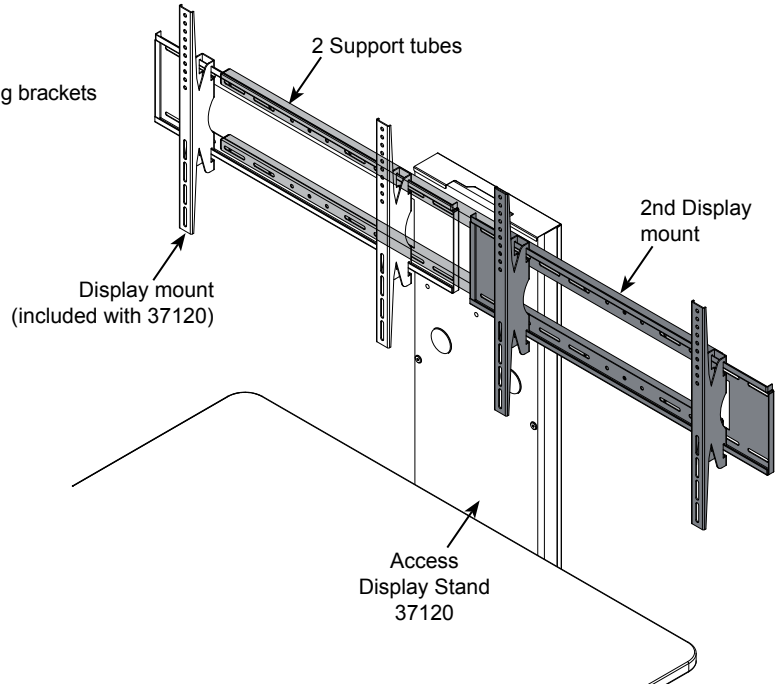

Note: The Dual Display Mount is not compatible with the Display Shroud.

Two-vertical positions available
(dimensions shown to center of mount)

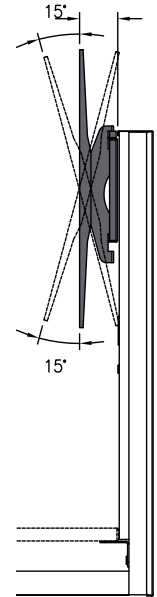
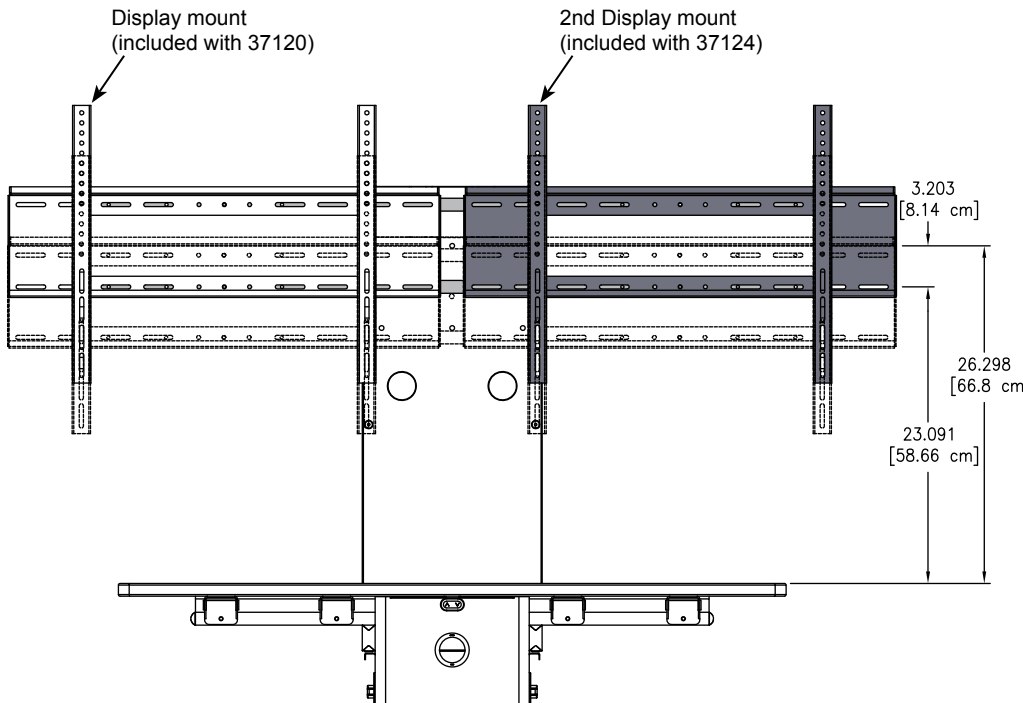

InVision Access Equipment Rack 8RU - 37123

- Provides rack storage next to table
- Equipment rack can be integrated off-site, then wheeled into place
- Single cam locking front and rear panels
- Glides and casters included for stationary or mobile use (glides can be unscrewed to raise unit off casters for stationary use)
- Ventilated side panels help dissipate heat
- Access panels (one clear acrylic, one solid) provide easy monitoring and access to internal equipment
- Laminate worksurface
- Grommet holes in worksurface and base panel provide cord access
- Includes 2 wire looms to route wires to / from table

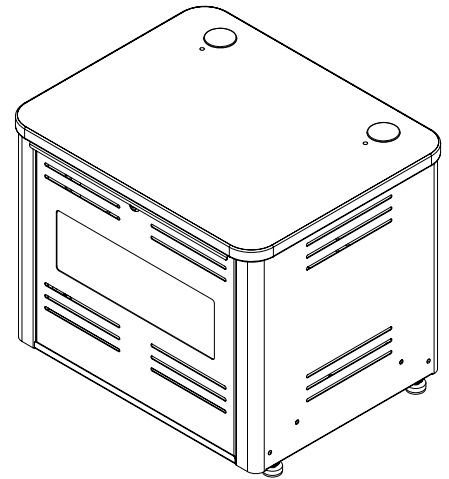

Capacity	8RU
Available colors	CHB, FMB, FMS, IB, IS, WFB, WFS
Wire looms	.75" dia [1.9 cm] x 64" [162.6 cm] length (includes 2)
Box dimensions (nominal)	N/A
Weight (nominal)	64 lb [29 kg]

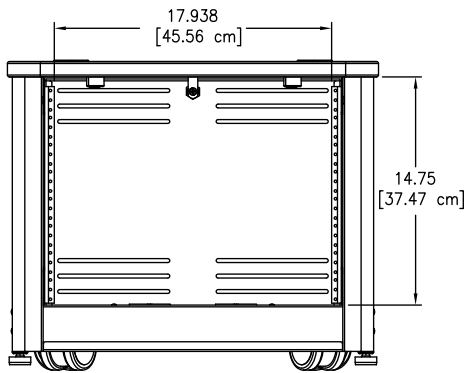

Front view
(shown with front panel removed)

Note: Rack-mount accessories with a depth greater than 14.331" [36.4 cm] will not fit in the Access equipment rack. Check the dimensions of all equipment before installation.

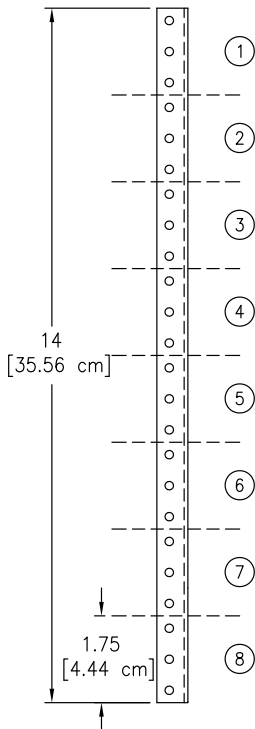
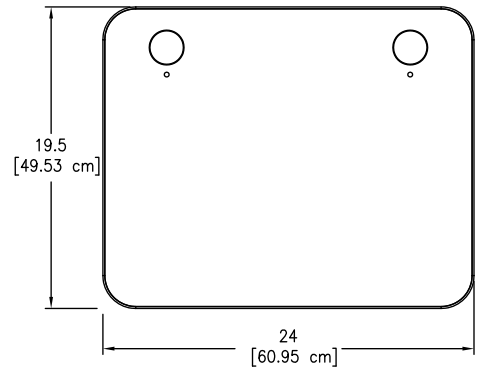

8RU available

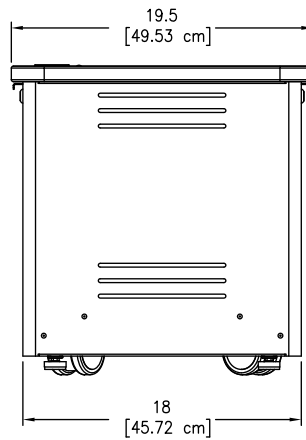

Section view A-A

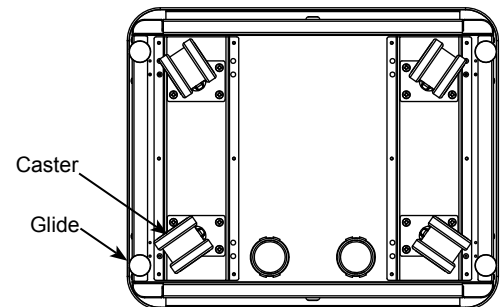
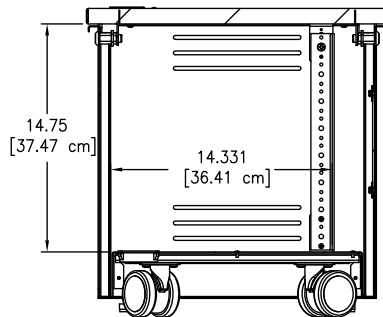
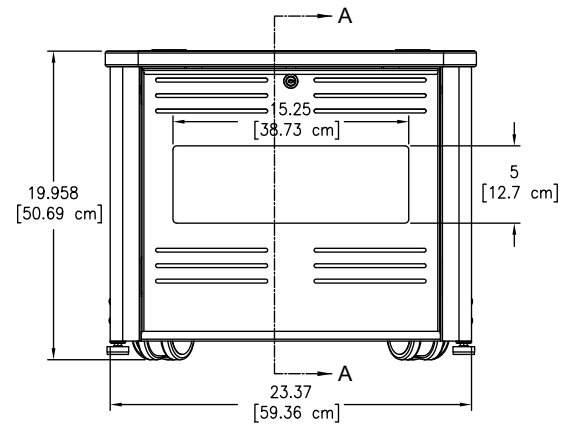

Bottom view

Warranty

WE WILL MAKE IT RIGHT FOR YOU!

Spectrum is committed to provide complete customer satisfaction. Each of our products is manufactured from the best materials available and each product is stringently monitored throughout the production process through our P.A.C.E. program (Product Assurance to meet Customer Expectations).

We expressly warrant that Spectrum products will be of good quality and workmanship and free from defect for the period set out in the warranty table below from the date of delivery. This warranty shall not apply to defects or damage resulting from misuse, abuse, neglect, improper care, modification or repair not authorized by Spectrum, or any other cause outside the control of Spectrum. Spectrum will, at its sole option, either repair or replace the defective product.

This warranty is exclusive; no other warranty, written or oral, is expressed or implied. This warranty is given by Spectrum to Buyer and to no other person or legal entity. No Spectrum dealer, distributor, agent or employee is authorized to make any modification or addition to this warranty.

NOTWITHSTANDING ANYTHING TO THE CONTRARY, SPECTRUM WILL NOT UNDER ANY CIRCUMSTANCES BE LIABLE FOR INDIRECT OR LIQUIDATED DAMAGES, INCLUDING CONSEQUENTIAL, INCIDENTAL AND SPECIAL DAMAGES. IN NO EVENT SHALL SPECTRUM'S LIABILITY, WHETHER UNDER CONTRACT OR WARRANTY, IN TORT OR OTHERWISE, EXCEED THE PURCHASE PRICE RECEIVED BY SPECTRUM FOR THE PRODUCT AT ISSUE AND "RECALL ACTION" EXPENSES. SPECTRUM SHALL NOT BE SUBJECT TO ANY OTHER OBLIGATIONS OR LIABILITIES, WHETHER ARISING OUT OF BREACH OF CONTRACT, WARRANTY, TORT (INCLUDING NEGLIGENCE AND STRICT LIABILITY) OR OTHER THEORIES OF LAW, WITH RESPECT TO PRODUCTS SOLD OR SERVICES RENDERED BY SPECTRUM, OR ANY UNDERTAKINGS, ACTS OR OMISSIONS RELATING THERETO.

Our Customer Service Department is ready to provide immediate attention to any questions, comments or concerns. They are available to answer your calls Monday through Friday from 7 am to 5 pm CST. In addition your product comments or concerns are welcome via e-mail at: spectrum@spectrumfurniture.com.

Warranty Table

effective 1/1/2015

Item	Warranty Period
Adjustable Crank/Electric Desk Legs	• 1 Year
Flat Panel Desk Gas Cylinders	
Chairs <ul style="list-style-type: none"> • Adjustable Height Chair Parts – including frames, gas cylinders, wood and plastic parts, control handles, casters • Adjustable Height Chair Upholstery • In-Stock Upholstery • Graded-In Fabrics and Customer Owned Material 	<ul style="list-style-type: none"> • 7 Years • 2 Years • 2 Years • No Warranty
Height Adjustable Columns and Lifts	• 1 Year
General Use Casters	
Electrical	• 2 Years
Keyboard/Mouse Trays	• 1 Year
Flat Panel Monitor Arms <ul style="list-style-type: none"> • Flat Panel Monitor Arm – General Parts • Flat Panel Monitor Arm – Gas Cylinders 	<ul style="list-style-type: none"> • 5 Years • 2 Years
Desks and Lecterns <ul style="list-style-type: none"> • Computer Desk Chassis • Cart Chassis • Lectern Chassis 	• 10 Years



205 Westwood Ave, Long Branch, NJ 07740
 Phone: 866-94 BOARDS (26273) / (732)-222-1511
 Fax: (732)-222-7088 | E-mail: sales@touchboards.com

