

Logo Panels

You can easily increase your organization's brand-awareness on a variety of Spectrum products by adding a custom logo. If you are interested in this option, please provide Spectrum with the preferred logo file at the time of quotation and your request will be reviewed, appropriately priced, and added to the quote.

1. What Spectrum needs to make a logo cutout:

Option A: (Preferred)

Vector-based "print-ready" art is the easiest to translate the logo to a laser cut metal panel. The preferred file types are AI, EPS, DWG or DXF. Most organizations have high quality vector-based logos on file for use with large signs, stadiums, and large-format advertisements. These files can often be obtained from a marketing or PR department.



Good quality vector-based logo image file (Preferred)

Touchboards

205 Westwood Ave, Long Branch, NJ 07740
Phone: 866-94 BOARDS (26273) / (732)-222-1511
Fax: (732)-222-7088 | E-mail: sales@touchboards.com

Option B:

(additional lead times and up-charges may apply)

As an alternative, Spectrum can trace a high resolution (300 DPI or higher) raster image file but additional lead times and up-charges may apply. Usable raster file types are black and white (high-contrast), have crisp edges when zoomed in, are high-resolution, and in JPG, PSD, GIFF or TIFF formats.



Poor quality raster logo image file

(More labor-intensive-additional lead times
& up-charges may apply)

2. Initial Customer Approval:

A preliminary Customer Approval Sheet is sent back for verification of size, location, and style, with the option of a color backer behind the logo.

CUSTOMER APPROVAL SHEET

Fax approval back to: 1-800-335-0473

Submitted By:
Quote#
Quote Date
Quote Expiration Date

Business Relation
Contact
Phone
Extension
Fax
E-mail



Metal color: Black

REQUESTED NON-STANDARD SOLUTION DETAILS

Qty-1 55303 Logo Panel for Freedom Lectern

Spectrum Logo on Freedom Lectern logo panel

No color backer required

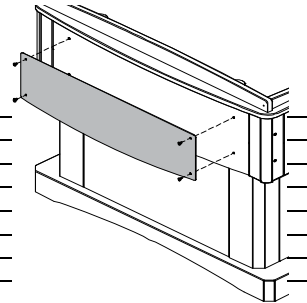

By signing the Customer Approval Sheet the customer agrees that all changes listed above are correct. No orders for non-standard products will be accepted without a signed Customer Approval Sheet.

****Non-Standard products are non-returnable, non-refundable and can require a lead time of up to 8-14 weeks depending on the complexity of the changes and the time of year.****

Approved by:

[Redacted signature area]

Date:

[Redacted date area]

Print Name:

[Redacted print name area]



1600 Johnson St. P.O. Box 400 Chippewa Falls, WI 54729 Ph. 1-800-235-1262 Fax. 1-800-335-0473
E-mail: spectrum@spectrumfurniture.com web: www.spectrumfurniture.com

**Filled out and signed
by customer**

3. Final Customer Approval:

After the preliminary customer approval, Spectrum's Engineering Department then sets up the logo for laser cutting and a second approval is sent back for final verification.

Because some features and letters may need tabs or bridging to hold them together, and logo features need to be interpreted into monochromatic (black or white) shapes, the laser cut logo panel may not exactly match your original logo artwork. Please pay special attention to these changes when approving a logo to ensure they encompass the original intent of the artwork. Any changes can be made at this time, and will be re-submitted for your approval.



Letter from original logo artwork

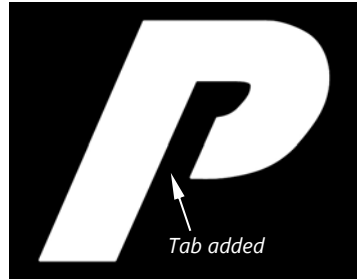

Actual cutout letter in metal panel

	<table border="1" style="width: 100%; border-collapse: collapse;"> <tr> <th>#</th> <th>Material Description</th> </tr> <tr> <td>1</td> <td>STEEL SH116GA CR</td> </tr> <tr> <td>2</td> <td>POWDERCOAT</td> </tr> <tr> <td>3</td> <td>CHEMICAL FLAVORIZATION RESIN</td> </tr> </table> <p>NOTES: -DIMENSIONS ARE TYPICAL -DEBURR</p>	#	Material Description	1	STEEL SH116GA CR	2	POWDERCOAT	3	CHEMICAL FLAVORIZATION RESIN																						
#	Material Description																														
1	STEEL SH116GA CR																														
2	POWDERCOAT																														
3	CHEMICAL FLAVORIZATION RESIN																														
<p>LOGO PANEL TO BE METAL, PAINTED: BLACK LOGO BACKER: NONE</p>																															
<p>"SPECTRUM" LOGO APPROVAL SHEET *APPROVAL SIGNATURES REQUIRED 3 PLACES</p> <p>LOGO SIZE: </p> <p>LOGO LOCATION: </p> <p>LOGO STYLE: </p>																															
<table border="1" style="width: 100%; border-collapse: collapse;"> <tr> <td colspan="2" style="text-align: center;">SPECTRUM INDUSTRIES INC.</td> <td style="font-size: small;">CHIPPENAW FALLS, WISCONSIN</td> </tr> <tr> <td colspan="3" style="font-size: x-small;">THIS DRAWING IS THE PROPERTY OF SPECTRUM INDUSTRIES AND IS PREPARED BY GENERAL AND IN DETAIL. IT SHALL NOT BE COPIED OR ITS CONTENTS REVEALED TO OUTSIDE PARTIES WITHOUT THE EXPRESSED WRITTEN CONSENT OF SPECTRUM INDUSTRIES INC. REVISED 8/09</td> </tr> <tr> <td style="font-size: x-small;">TITLE/ITEM DESCRIPTION</td> <td style="font-size: x-small;">DATE</td> <td style="font-size: x-small;">ITEM NO.</td> </tr> <tr> <td style="font-size: x-small;">DRAWN BY: GJH</td> <td style="font-size: x-small;">DATE: 12/11/2011</td> <td style="font-size: x-small;">DESIGNED BY: ELS</td> </tr> <tr> <td style="font-size: x-small;">CHECKED BY: LDK</td> <td style="font-size: x-small;">DATE: 9/6/2011</td> <td style="font-size: x-small;">PRINTED DATE: 12/6/2011</td> </tr> <tr> <td colspan="2" style="font-size: x-small;">TOLERANCES:</td> <td style="font-size: x-small;">DRAWING NO.:</td> </tr> <tr> <td style="font-size: x-small;">FRACTION</td> <td style="font-size: x-small;">2 DEC</td> <td style="font-size: x-small;">3 DEC</td> </tr> <tr> <td style="font-size: x-small;">±1/64</td> <td style="font-size: x-small;">±.01</td> <td style="font-size: x-small;">±.005</td> </tr> <tr> <td colspan="2"></td> <td style="font-size: x-small;">ANGLE ±1°</td> </tr> <tr> <td colspan="2"></td> <td style="font-size: x-small;">S-111176</td> </tr> </table>		SPECTRUM INDUSTRIES INC.		CHIPPENAW FALLS, WISCONSIN	THIS DRAWING IS THE PROPERTY OF SPECTRUM INDUSTRIES AND IS PREPARED BY GENERAL AND IN DETAIL. IT SHALL NOT BE COPIED OR ITS CONTENTS REVEALED TO OUTSIDE PARTIES WITHOUT THE EXPRESSED WRITTEN CONSENT OF SPECTRUM INDUSTRIES INC. REVISED 8/09			TITLE/ITEM DESCRIPTION	DATE	ITEM NO.	DRAWN BY: GJH	DATE: 12/11/2011	DESIGNED BY: ELS	CHECKED BY: LDK	DATE: 9/6/2011	PRINTED DATE: 12/6/2011	TOLERANCES:		DRAWING NO.:	FRACTION	2 DEC	3 DEC	±1/64	±.01	±.005			ANGLE ±1°			S-111176
SPECTRUM INDUSTRIES INC.		CHIPPENAW FALLS, WISCONSIN																													
THIS DRAWING IS THE PROPERTY OF SPECTRUM INDUSTRIES AND IS PREPARED BY GENERAL AND IN DETAIL. IT SHALL NOT BE COPIED OR ITS CONTENTS REVEALED TO OUTSIDE PARTIES WITHOUT THE EXPRESSED WRITTEN CONSENT OF SPECTRUM INDUSTRIES INC. REVISED 8/09																															
TITLE/ITEM DESCRIPTION	DATE	ITEM NO.																													
DRAWN BY: GJH	DATE: 12/11/2011	DESIGNED BY: ELS																													
CHECKED BY: LDK	DATE: 9/6/2011	PRINTED DATE: 12/6/2011																													
TOLERANCES:		DRAWING NO.:																													
FRACTION	2 DEC	3 DEC																													
±1/64	±.01	±.005																													
		ANGLE ±1°																													
		S-111176																													
SHEET 1 OF 1	REF: SEE 104511	X 8/29/2011																													
CR #	DESCRIPTION OF CHANGE	BY DATE																													

Signed by customer

4. Programming

After receiving the signed final approval, Spectrum Engineering begins programming for production.

5. Production

Spectrum's Production will laser-cut the logo panel and powder coat with the specified color. Any backer laminate is added and the unit is inspected and packed for shipping.

