

Assembly Instructions

Important

Before you begin, please make sure all parts and proper quantities are included. Any parts damaged during shipment must be reported within 15 days of receipt. To report information regarding damage, to purchase parts or accessories, or if you have any questions, please contact us at:

www.spectrumfurniture.com
715-723-6750, 800-235-1262

Thank you for purchasing Spectrum products!

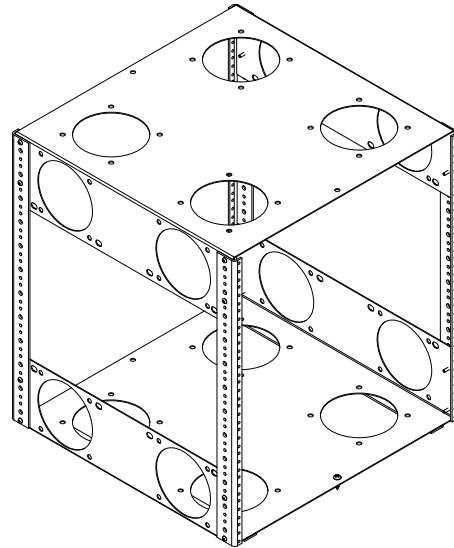

Rack Cube 55197

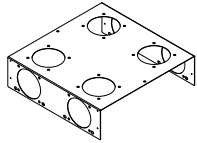

(1) 0118596
Cube top



(1) 0101382
#14 x 7/8" PHSM
screw

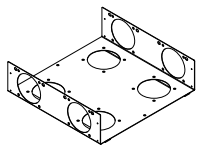

(1) 0118879
Cube bottom



(16) 0100167
8-32 x 1/2" PH
thread-cutting
screw

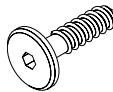

(4) 0102297
7mm x 30mm JCW
screw



(4) 052436
Rack rail (21")



(4) 0107139
Bumper Stop



(1) 025039
4mm Hex
wrench

Tools Required



Drill with
Phillips
driver



Phillips
Screwdriver



4mm Hex
Wrench
(included)

1. Assemble Cube

1. Assemble the cube top, bottom, and four rack rails using (16) 8-32 x 1/2" PH thread-cutting screws. Note the orientation of the rails. **Figure 1.**
2. Tighten screws securely.

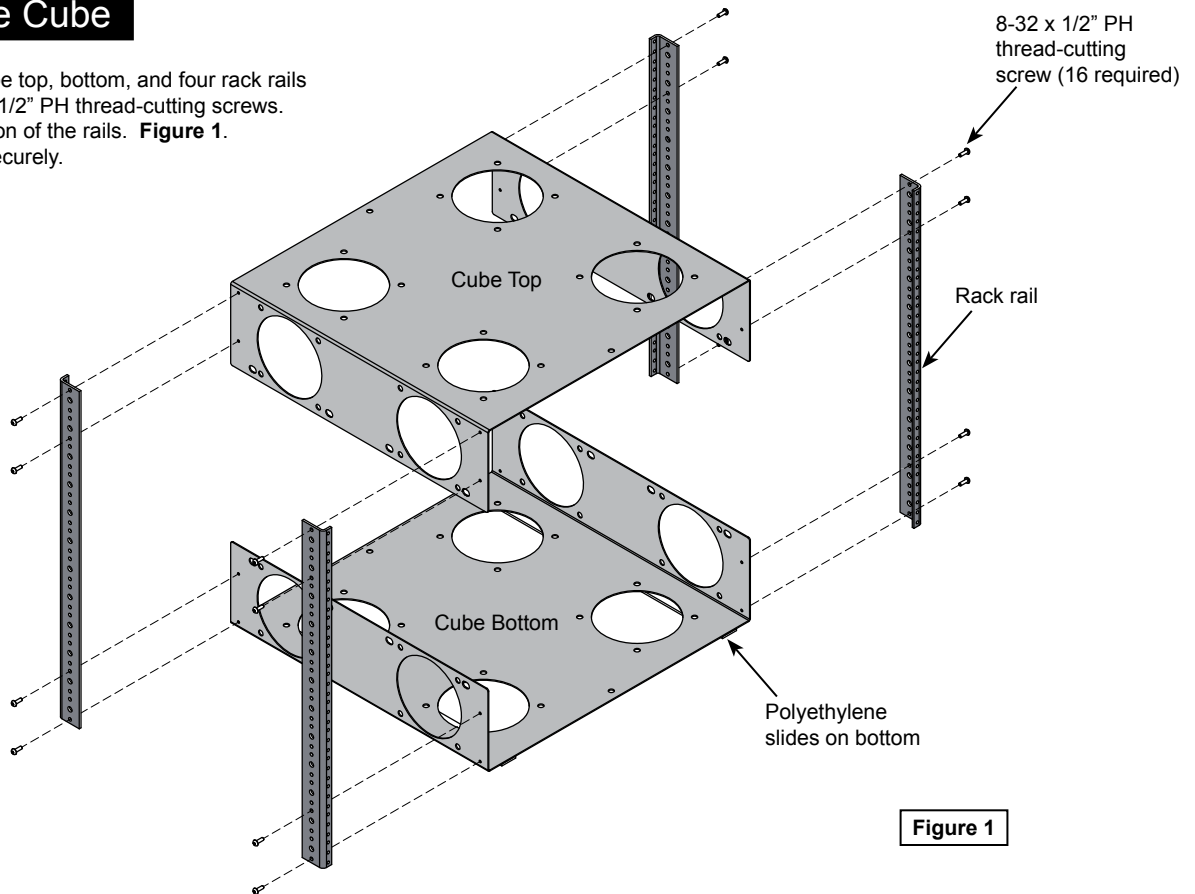

Figure 1

2. Install Cube

1. Determine which side of the lectern the cube will be installed (left or right side).
Removing the doors using the quick-release levers will provide better access.
2. Install the (4) bumper stops to the base panel as shown with one 7mm x 30mm JCW screw each. **Figure 2.**
3. Install the cube assembly into the lectern.
4. Secure the cube to the base panel with (1) #14 x 7/8" PHSM screw and tighten securely.
5. The bumper stops can be rotated if adjustment is necessary.

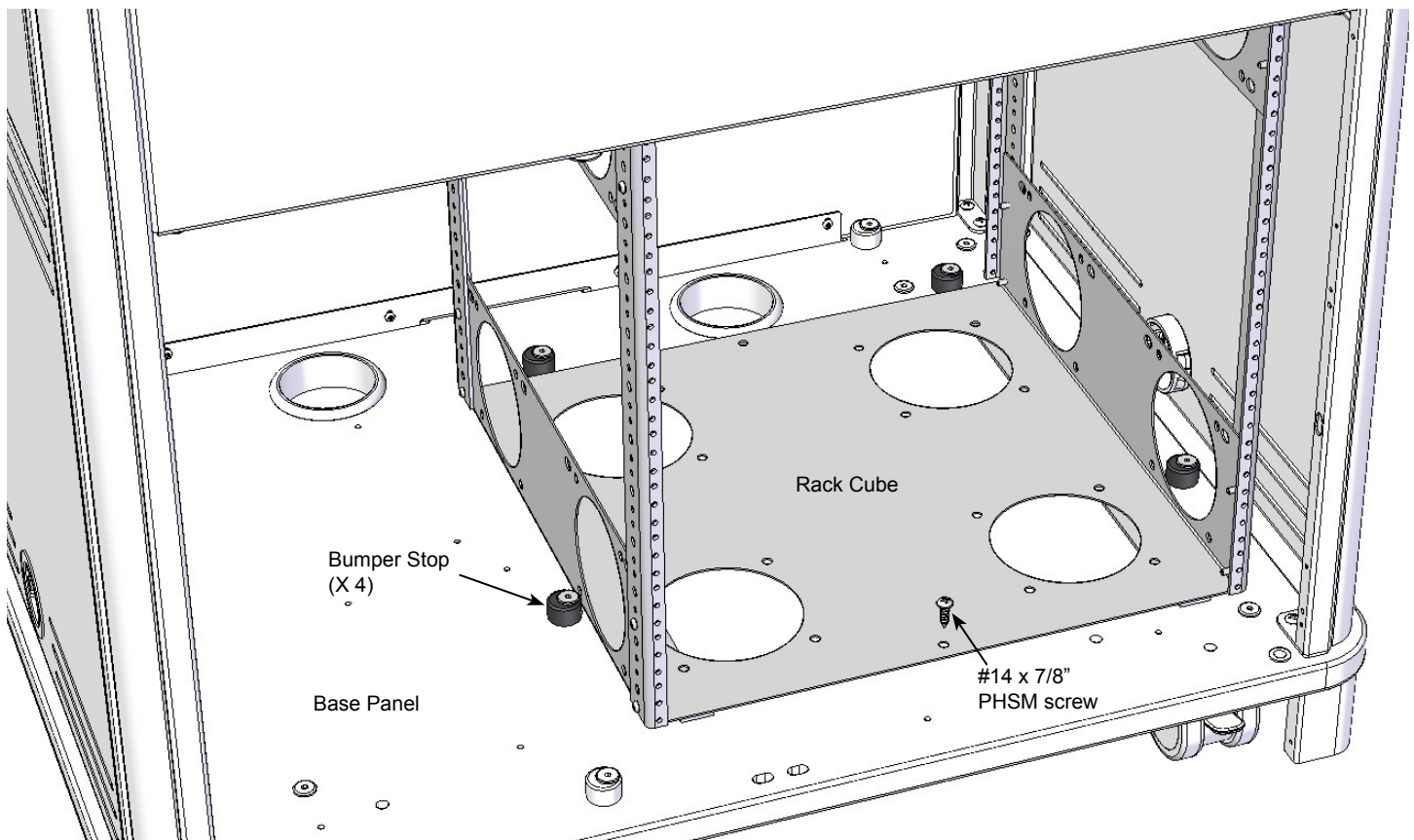

Figure 2

The rack cube provides 12RU of rack space and is easily removed from the lectern. This simplifies installation of equipment and provides the ability to integrate equipment remotely. The cube can be installed into the lectern at a later date or when convenient.

The cube also provides mounting capabilities for multiple cooling fans if necessary. Compatible with most 4.75" cooling fans with 4.13" mounting hole spacing (12 mounting locations available).

Touchboards

205 Westwood Ave, Long Branch, NJ 07740
Phone: 866-94 BOARDS (26273) / (732)-222-1511
Fax: (732)-222-7088 | E-mail: sales@touchboards.com