

Technical Specifications

SIM32 Cart w/ Power Switch - 55494-FBR

SIM32 Cart w/ eLogix™ Timer - 55494-FBT

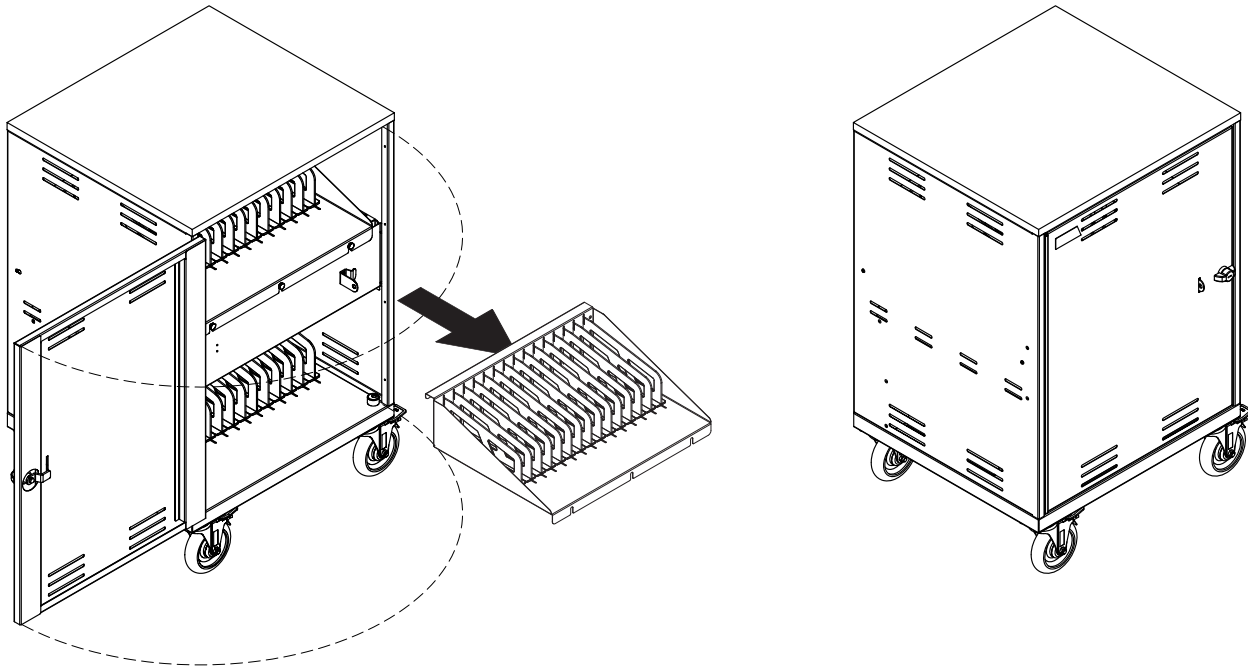

Use the SIM32 Cart to store, transport, and charge up to 32 devices. Two charging options are available. Flexible dividers protect the devices. The cart's compact footprint and integrated handle provides easy mobility. The economical SIM32 cart is made with heavy-gauge steel for security and powder-coated for a durable, long-lasting finish. Locking door increases device security.



Features and Benefits

- Stores, charges, and transports up to 32 devices (most Chromebooks, tablets*, and notebooks up to 15.6" diagonal)
- 1.25"W x 17"D x 11"H storage bay
- Easy front-loading design simplifies deployment
- Small cart footprint (24"W x 22"D) saves valuable space
- Durable ABS plastic dividers protect notebooks from scratching (dividers are removable to provide storage space for thicker devices)
- Removable upper divider / mid panel tray provides access to wiring and power underneath
- Recessed power / cord wrap design eliminates damage through doorways
- Door features a locking single-point steel lock with padlock hasp for additional security. (Padlock not included).
- Devices and students are separated from AC line voltage
- Superior cord management system keeps charge cords organized and routed to each bay
- Replaceable, IEC (quick-release) 8' nominal 14 AWG, 3-wire power cord and external recessed cord wrap brackets provide easy power access
- Four inboard 5" balloon wheel plate casters (two locking, two non-locking) with metal construction and non-marring rubber provide easy rolling, and quiet transport (rated for 300 lb each)
- Integrated handle provides control and maneuverability
- Cart ships fully-assembled for quick, simple integration and deployment
- Durable powder coated steel chassis provides a long-lasting finish
- ETL recognized (certified to UL 60950-1) in the US and Canada for the cart and electrical system
- Warranted to be free of all defects in materials and workmanship for 10 years, electrical system 2 years
- Designed and assembled in Chippewa Falls, WI, USA

Available with:

- eLogix™ timer provides cycling power to both power units (non current-sensing) ***For most power adapters up to 65W**
- Power switch provides continuous power to both power units (non current-sensing) ***For most power adapters up to 35W**

Color Options

Warm Gray



Black
(top panel)

Construction

- 20-gauge door, side panels, and base
- All metal components are finished with a scratch-resistant powder coat epoxy
- ABS plastic dividers
- Top panel is constructed from 3/4" NAF (No Added Formaldehyde) composite board
- Top panel edges are covered with 3mm vinyl edgeband
- This cart is factory-assembled, packaged, and shipped on its own skid

Specifications

Capacity	32 devices. (Most Chromebooks, tablets*, or notebooks)	
Storage bays (nominal)	1.25"W [3.17 cm] x 17"D [43.19 cm] x 11"H [27.94 cm]	
Electrical	<ul style="list-style-type: none"> • 16-outlet power units • 125V~/12A, 60Hz • 15-amp breaker • IEC quick-release (replaceable) 8' nominal, 14 AWG, 3-wire power cord 	<ul style="list-style-type: none"> • Mid panel isolates and separates electrical line voltage from students • ETL recognized (certified to 60950-1)
Charging options (See p.4 for specs)	<p>⚠ Note: The customer should be aware of the amp draw of the devices used with this cart-especially when maxing out the storage and charging capacity. Exceeding 15 amps will trip the circuit breaker. Please consult the owners manual of your specific device for power consumption information.</p>	
5" Balloon Wheels	Weight capacity 300 lb [136.2 kg] each (two locking, two non-locking)	
Certifications / Compliance	<ul style="list-style-type: none"> • ETL recognized • SCS Indoor Advantage Certified 	<ul style="list-style-type: none"> • Meets or exceeds applicable ANSI-BIFMA test standards
Unit weight (nominal)	98 lb [44.5 kg]	
Shipping weight (nominal)	130 lb [59 kg]	

Specifications subject to change without notice

Note: Do not place items weighing more than 50 lb [22.7 kg] on the top surface. Please remove or secure items before moving cart.

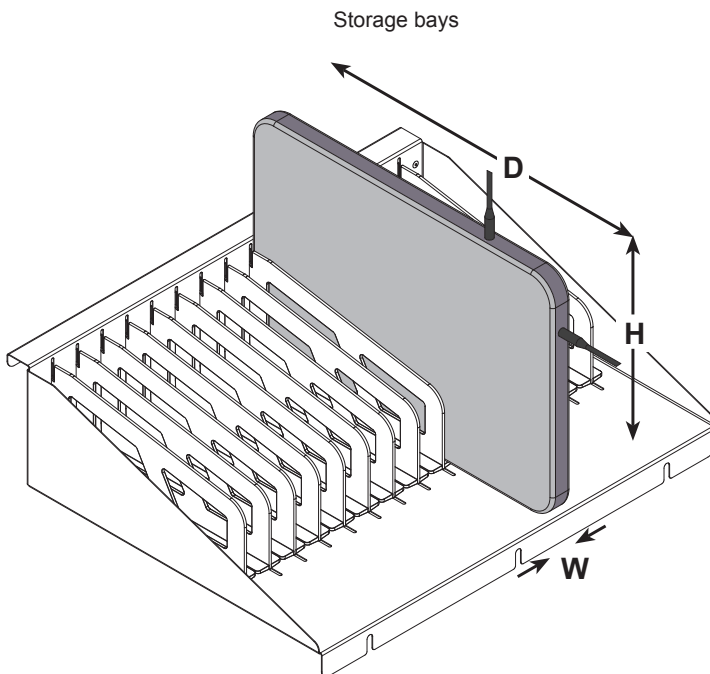

Devices must be placed in the bays with the charge plug on one of the two exposed edges shown.

5" Balloon Wheel

Note: (2) locking, and (2) non-locking casters are included on each unit.

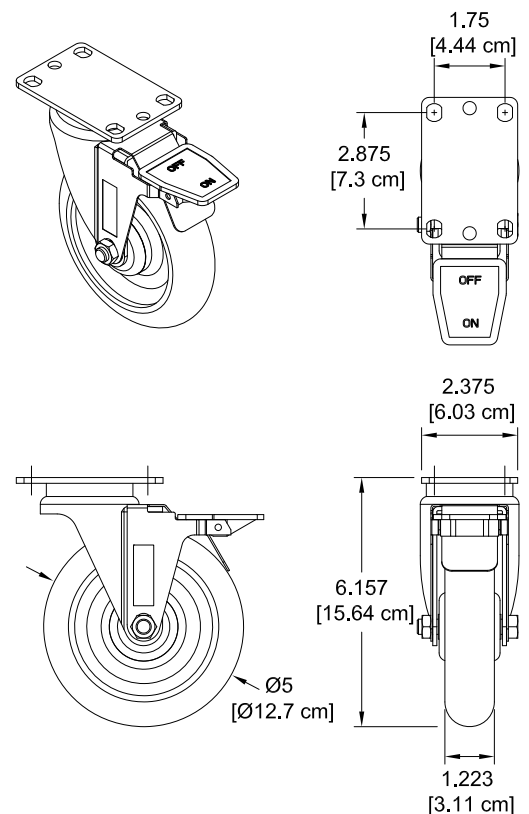

SIM32™ Electrical comparison		
eLogix™ Timer	Power Switch	
	✓	Top auxiliary outlet
✓	✓	Bottom auxiliary outlet
✓	✓	ON/OFF switch
✓		Load-sensing technology
✓		2 bank
	✓	4 bank
✓		*For most power adapters up to 65W
	✓	*For most power adapters up to 35W
✓		LED lights indicate charging status
✓	✓	ETL certified to 60950-1

**Total maximum wattage will be effected by actual charge adapter wattage and number of charge adapters per cart. See more wattage / adapter information below.*

eLogix™ Timer (T)

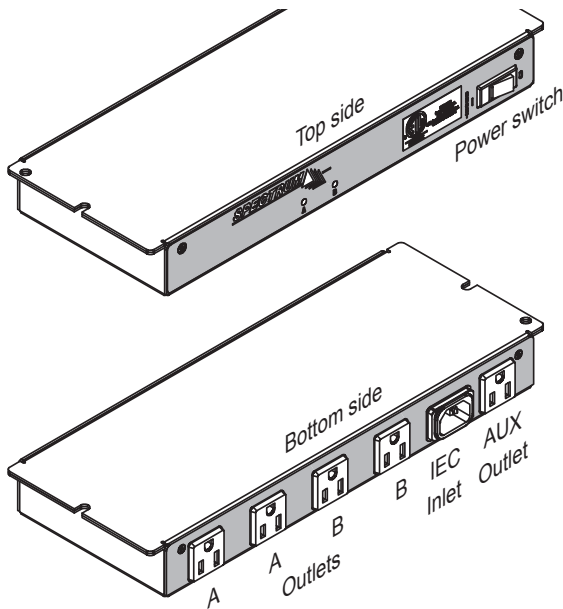

The eLogix™ timer charges one half of the devices for 15 minutes, then charges the second half of the devices for another 15 minutes. This cycling occurs automatically and is not adjustable. On the SIM32, the eLogix™ Timer can be used with most power adapters up to 65W.

- Two timed power-unit dedicated outlets (labeled A, B) (up to 10A power output)
- Two green LED lights indicate charging activity status of each power unit
- One auxiliary outlet (bottom)
- ETL recognized (certified to 60950-1)

Input:	125V~/12A, 60Hz
Breaker:	15A, 250 VAC
Cycling interval:	15 minutes
Cycling outlets:	4 timed (A, B) up to 10A
Auxiliary outlet:	1A (controlled by main power switch)
Power Cord:	IEC quick-release (replaceable) 8' nominal, 14 AWG, 3-wire
Power switch:	15A

Power Switch (R)

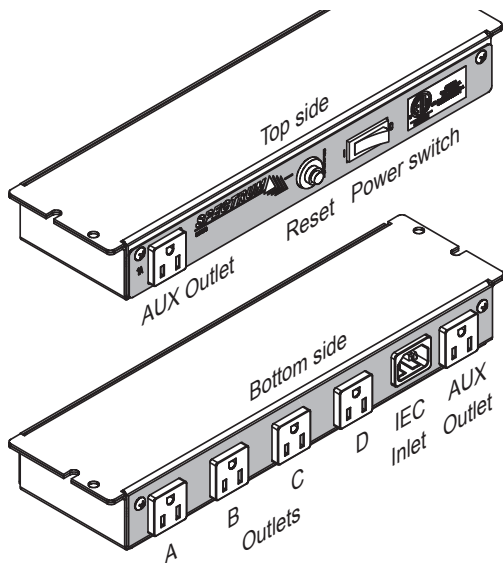

The Power Switch provides continuous power to all power units. Use with lower amp-draw devices. On the SIM32, the Power Switch can be used with most power adapters up to 35W.

- Four continuous power-unit dedicated outlets (labeled A, B, C, D)
- Two auxiliary outlets (1 top, 1 bottom)
- ETL recognized (certified to 60950-1)

Input:	125V~/12A, 60Hz
Breaker:	15A, 250 VAC
Outlets:	4 timed (A, B, C, D) up to 10A
Auxiliary outlets:	1A each (controlled by main power switch)
Power Cord:	IEC quick-release (replaceable) 8' nominal, 14 AWG, 3-wire
Power switch:	15A

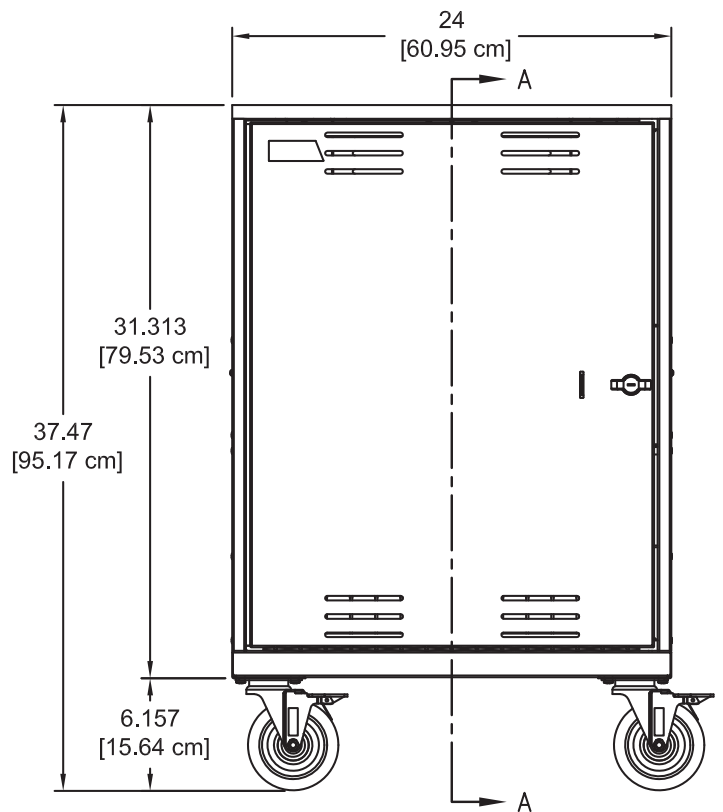
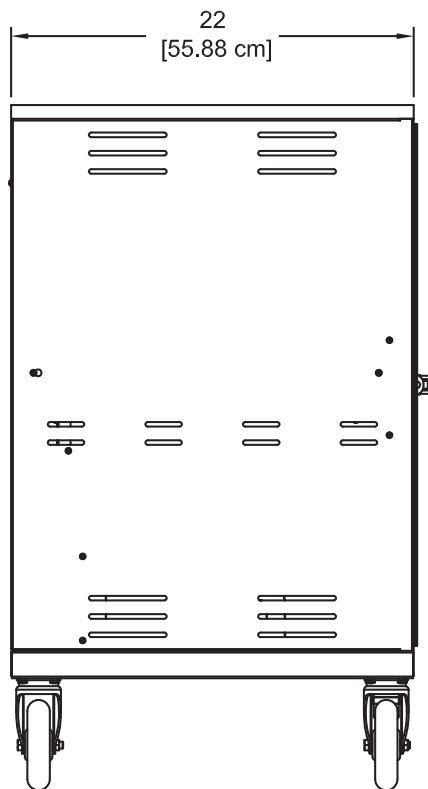
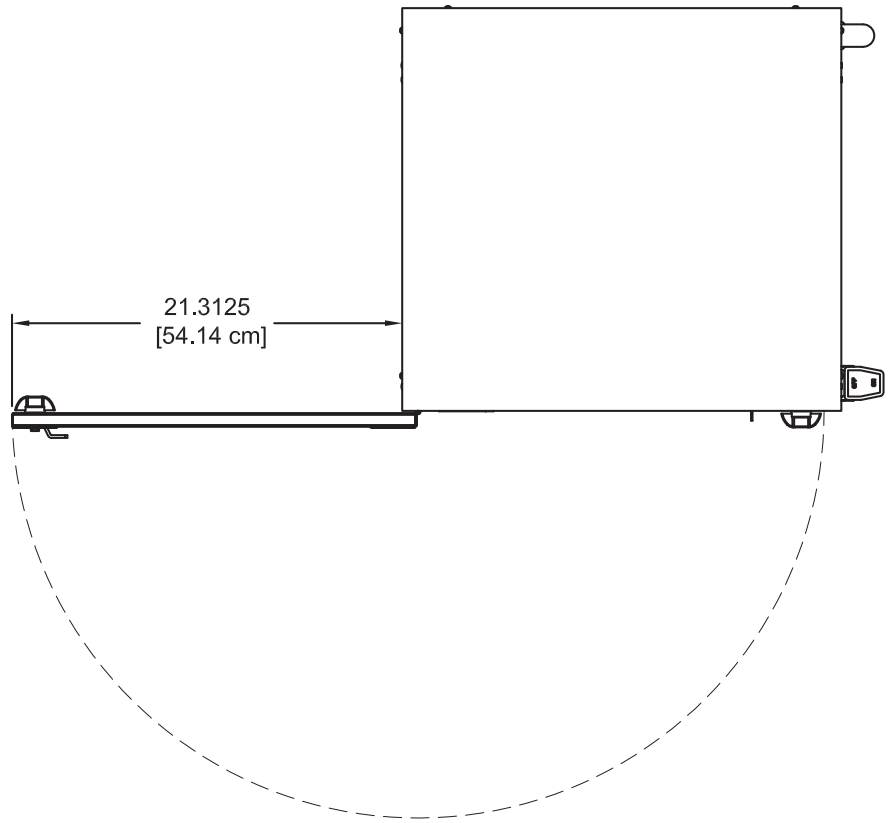
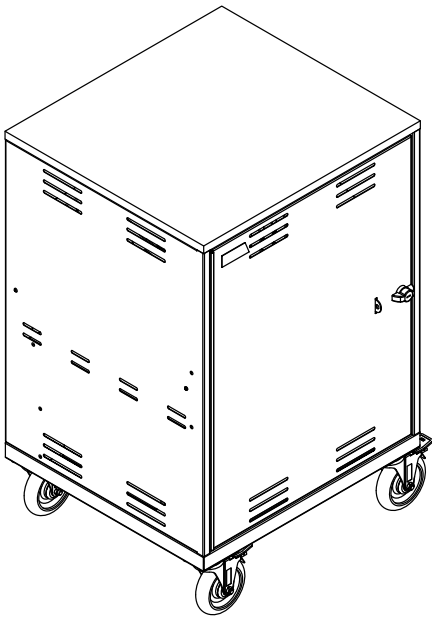

SIM32
Section view A-A

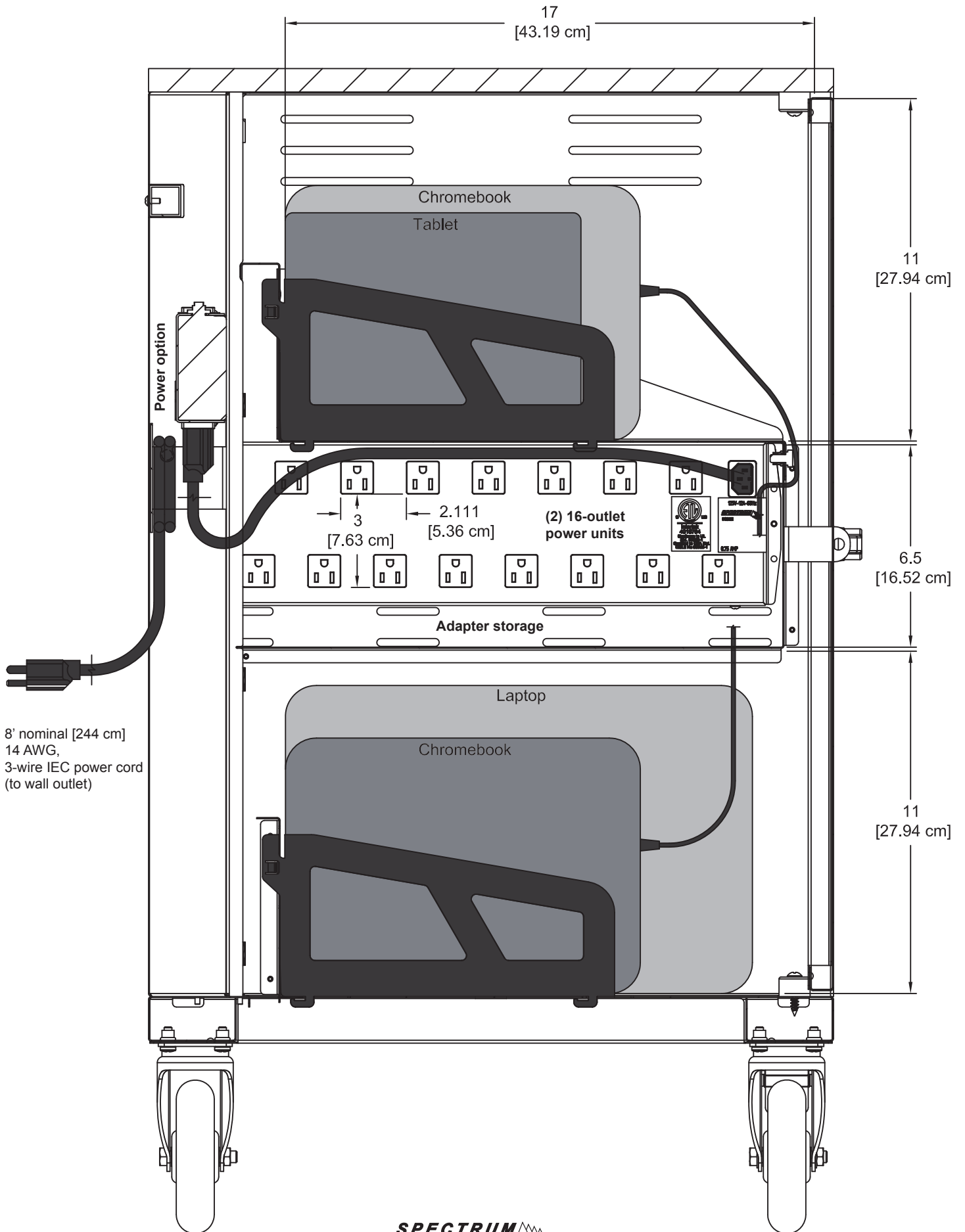

8' nominal [244 cm]
14 AWG,
3-wire IEC power cord
(to wall outlet)

SIM32
Device wiring diagram
(shown with door open)

1.25
[3.17 cm]

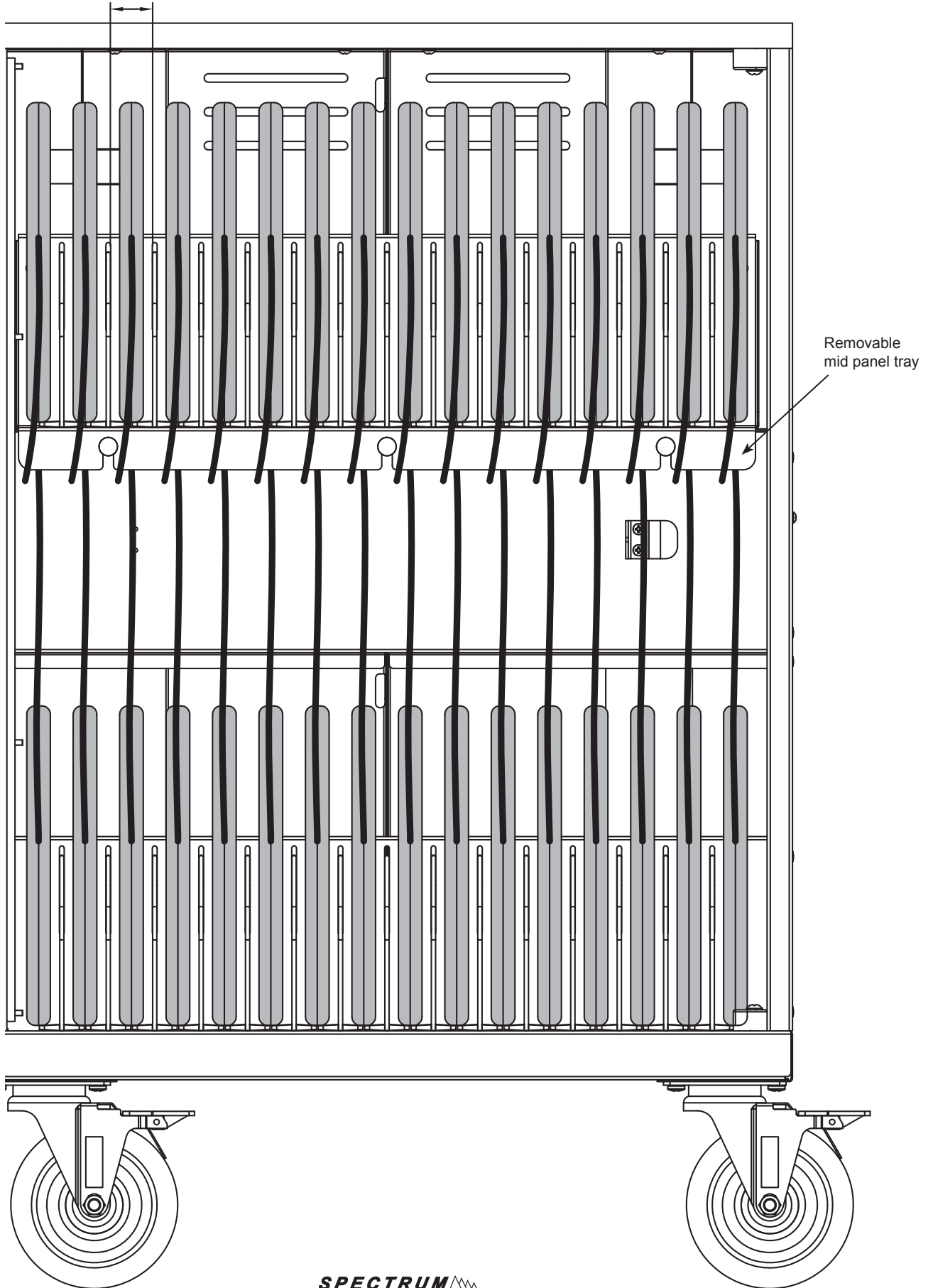

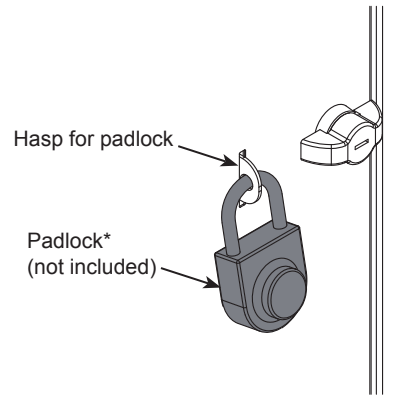
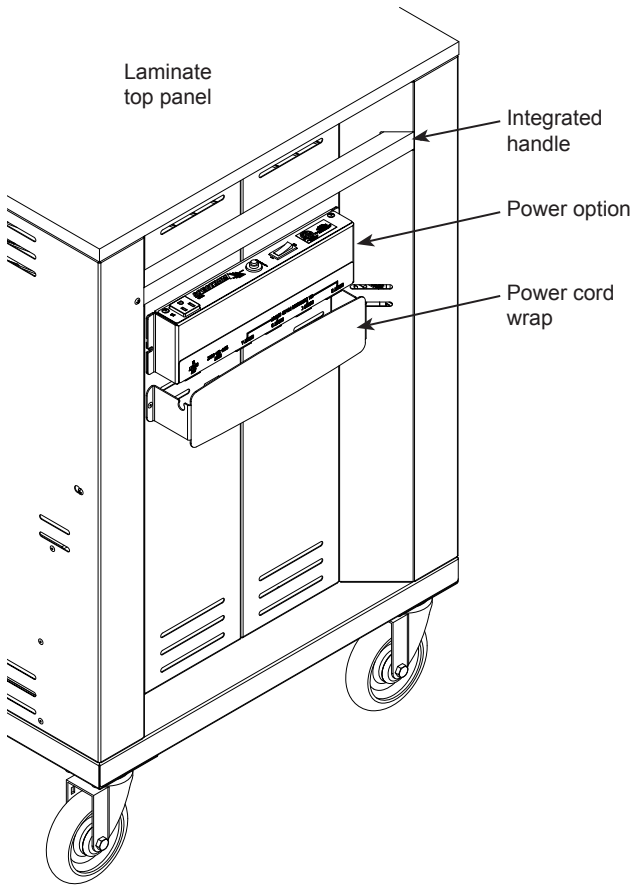

*Padlocks with a shackle diameter up to 11/32" [9mm] can be used

Accessories

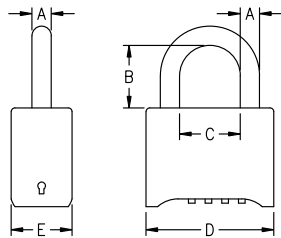

A	.3125" [7.9 mm]
B	1" [25.4 mm]
C	.983" [25 mm]
D	2.07" [52.5 mm]
E	.987" [25.1 mm]

Re-programmable 4-digit Combination Lock - 95536

- Set your own 4-digit personalized combination (up to 10,000 options)
- 5/16" hardened steel shackle for cut-resistance
- Black powdercoated die-cast body for durability
- Change key included
- Unit weight: .55 lb [.25 kg]

Hook-and-loop Strap Kit - 95004

(16) .75" [1.91 cm] x 12" [30.48 cm],
and (32) .75" [1.91 cm] x 5" [12.7 cm]

See spectrumfurniture.com for the latest accessories and detailed warranty information.

Warranty

We will make it right for you!

Spectrum is committed to provide complete customer satisfaction. Each of our products is manufactured from the best materials available and each product is stringently monitored throughout the production process through our Quality Management System.

We expressly warrant that Spectrum products will be of good quality and workmanship and free from defect for the period set out in the warranty table below from the date of delivery. This warranty shall not apply to defects or damage resulting from normal wear and tear, misuse, or unintended use, failure to follow instructions related to the product's installation or intended use, abuse, neglect, improper care, modification or repair not authorized by Spectrum, or any other cause outside the control of Spectrum. Spectrum will, at its sole option, either repair or replace the defective product.

This warranty is exclusive; no other warranty, written or oral, is expressed or implied. This warranty is given by Spectrum to Buyer or Buyer third party end user and to no other person or legal entity. No Spectrum dealer, distributor, partner, reseller, agent or employee is authorized to make any modification or addition to this warranty.

NOTWITHSTANDING ANYTHING TO THE CONTRARY, SPECTRUM WILL NOT UNDER ANY CIRCUMSTANCES BE LIABLE FOR INDIRECT OR LIQUIDATED DAMAGES, INCLUDING CONSEQUENTIAL, INCIDENTAL AND SPECIAL DAMAGES. IN NO EVENT SHALL SPECTRUM'S LIABILITY, WHETHER UNDER CONTRACT OR WARRANTY, IN TORT OR OTHERWISE, EXCEED THE PURCHASE PRICE RECEIVED BY SPECTRUM FOR THE PRODUCT AT ISSUE AND "RECALL ACTION" EXPENSES. SPECTRUM SHALL NOT BE SUBJECT TO ANY OTHER OBLIGATIONS OR LIABILITIES, WHETHER ARISING OUT OF BREACH OF CONTRACT, WARRANTY, TORT (INCLUDING NEGLIGENCE AND STRICT LIABILITY) OR OTHER THEORIES OF LAW, WITH RESPECT TO PRODUCTS SOLD OR SERVICES RENDERED BY SPECTRUM, OR ANY UNDERTAKINGS, ACTS OR OMISSIONS RELATING THERETO.

Our Customer Service Department is ready to provide immediate attention to any questions, comments or concerns. They are available to answer your calls Monday through Friday from 7 am to 5 pm CST. In addition your product comments or concerns are welcome via e-mail at: spectrum@spectrumfurniture.com.

Warranty Table

Item	Warranty Period
Desk, table, cart and lectern chassis	10 Years
Electrical	2 Years
Flat panel monitor arms / gas spring / general parts	2 Years
Adjustable crank / electric legs and accessories	2 Years
Flat panel desk gas spring cylinders	2 Years
Height adjustable columns, lifts & accessories	2 Years
Casters & wheels	2 Years
Keyboard, mouse, trays	2 Years
Locks & keys	2 Years
Tubs, totes and other accessories	1 Year
Chairs Structural components, including gas cylinders, wood, metal and plastic parts (i.e., chair frames, bases and control handles)	7 Years
Consumable items (i.e., casters, glides, etc.)	5 Years
In-stock upholstery	5 Years
Customer supplied material	No Warranty

