

Assembly Instructions

Important

Before you begin, please make sure all parts and proper quantities are included. Any parts damaged during shipment must be reported within 15 days of receipt. To report information regarding damage, to purchase parts or accessories, or if you have any questions, please contact us at:

www.spectrumfurniture.com
 715-723-6750, 800-235-1262

Thank you for purchasing Spectrum products!

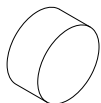

(2) 044573
 5/8" adhesive
 bumpers

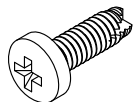

(4) 0100167
 8-32 x 1/2" PH
 thread ctg screw

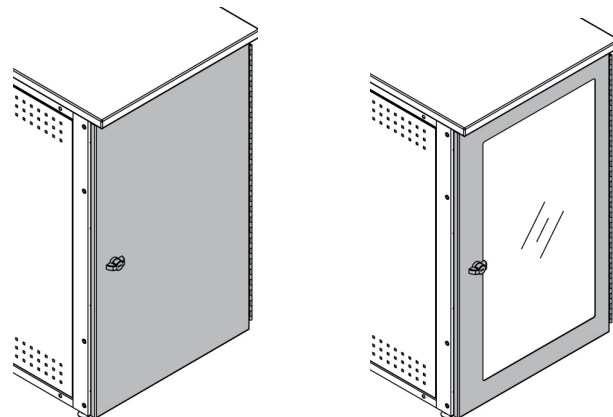

Locking door for IMC

68102 - 29" Solid Door
 68152 - 36" Solid Door

68103 - 29" Acrylic Door
 68153 - 36" Acrylic Door

1. Attach door to equipment rack

1. The locking door is symmetrical and can be mounted to swing from the left or right-side of the equipment rack. Before you begin, determine which side the door will be attached.
2. With the hinge open, align the mounting holes as shown and attach to equipment rack frame with (4) 8-32 x 1/2" PH thread cutting screws. Be sure the screws are installed straight. Do not tighten completely until all screws are installed. **Figure 1.**

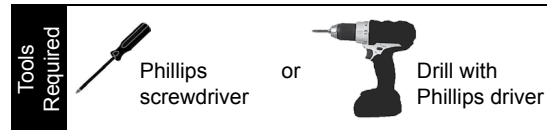

2. Install bumpers

1. With the door open, install the (2) adhesive bumpers onto the equipment rack frame as shown. **Figure 2.**

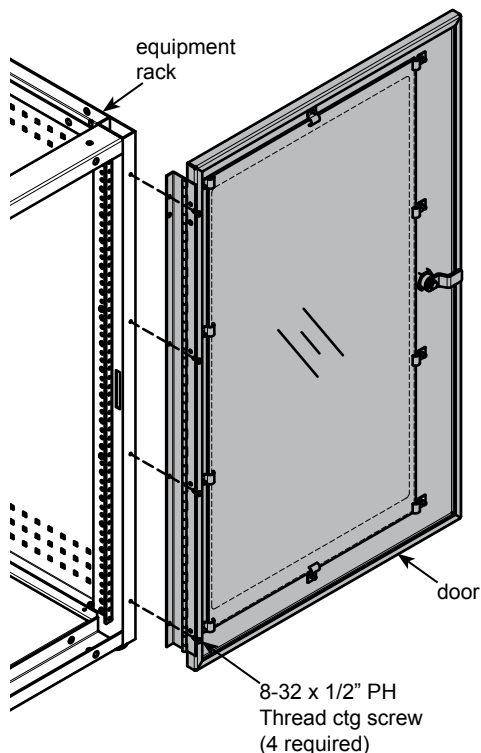

Figure 1

Note: If using an electric drill with Phillips driver to install, be sure to use the torque setting to prevent stripping out the screw holes.

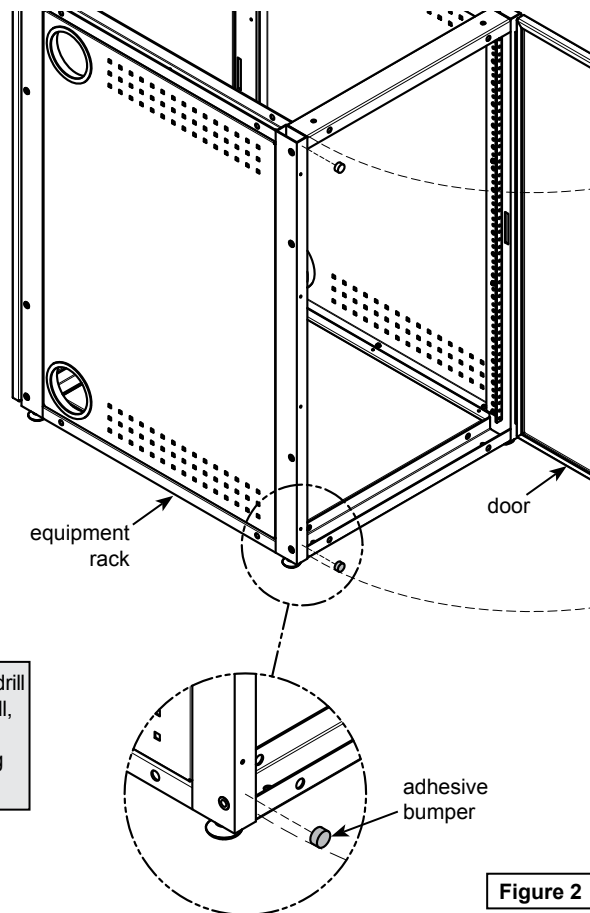

Figure 2