

Instructions:

To purchase parts or accessories, please contact us at
www.spectrumfurniture.com
1-800-235-1262
Thank you for choosing Spectrum products!



(4) 052605
1/4-20 x 15mm JC Bolt



(1) 025039
4mm Hex Wrench

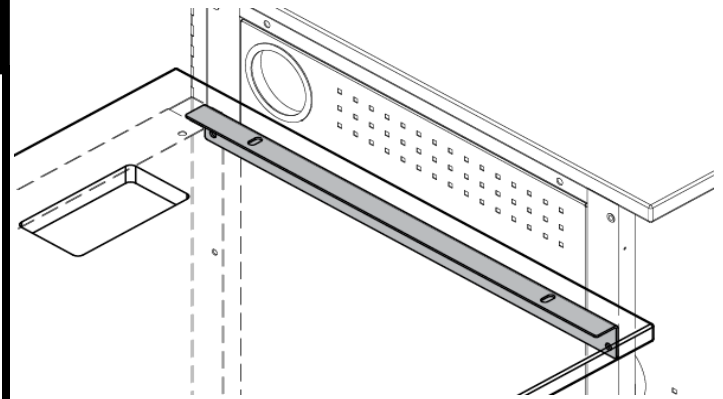

Before you begin, please make sure all parts and proper quantities are included. Any parts damaged during shipment must be reported within 15 days of receipt. To report information regarding damages or if you have any questions, please call 1-800-235-1262.

Stepped-Height Bracket for Instructor Media Console #68205

Tools Required:
4mm Hex Wrench (included)

1. Bracket Installation

- Before installation, assemble and attach the lower (29"H) wall filler panels, equipment racks and any end-support or mid-support legs. **The adjacent wall filler panel will need to be attached to the 36" equipment rack before the bracket is installed.**
- Align the bracket with the (2) mounting holes in the side of the 36"H equipment rack as shown. **Figure 1.**
- Attach with (2) 1/4-20 x 15mm JC Bolts, and tighten securely.

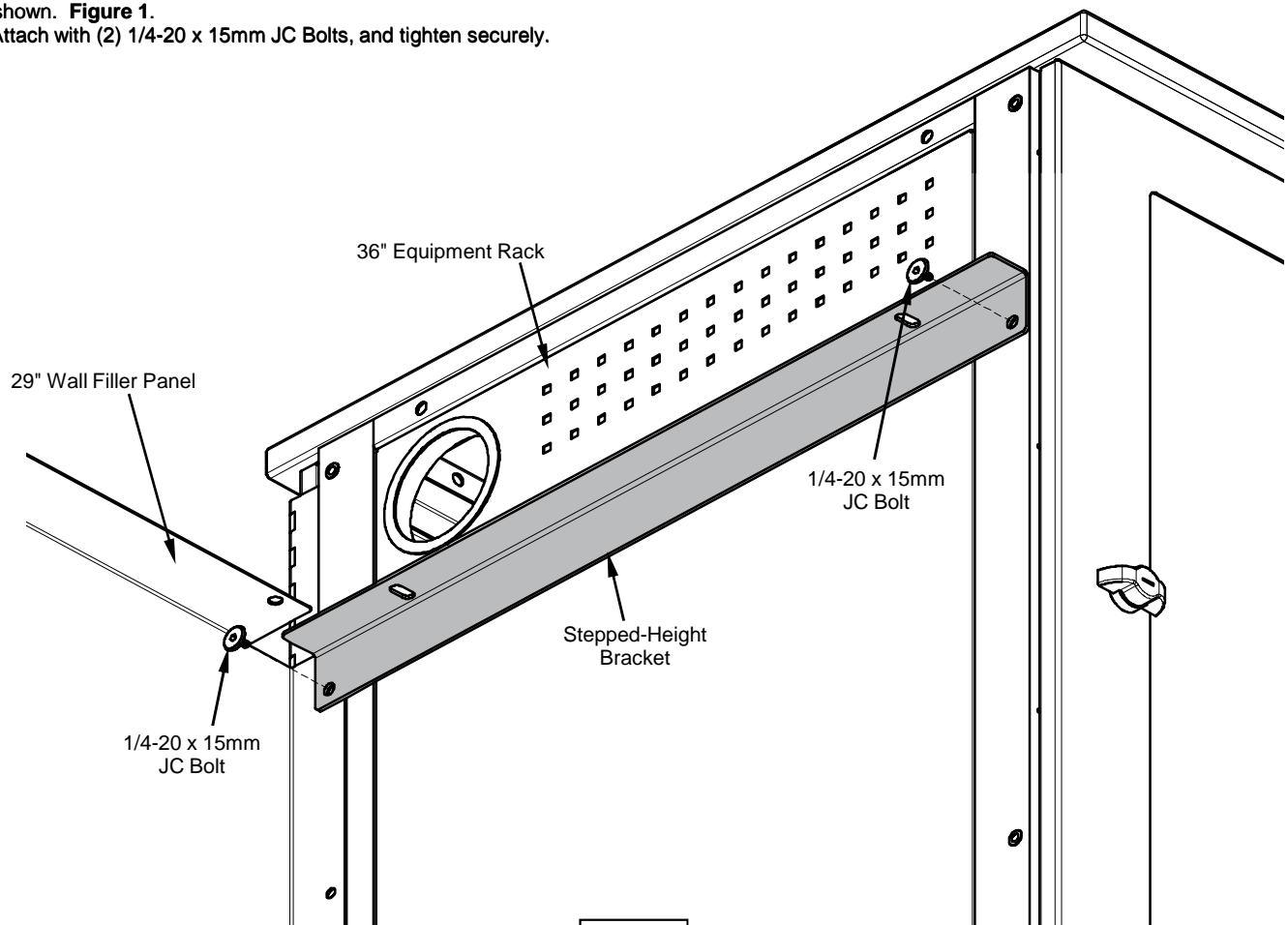

Figure 1

2. Work surface Installation

- A. Set the work surface onto the installed 29" wall filler panel(s) and the stepped-height bracket as shown in **Figure 2**.
B. Align the mounting holes and attach the work surface to the bracket with (2) 1/4-20 x 15mm JC bolts.

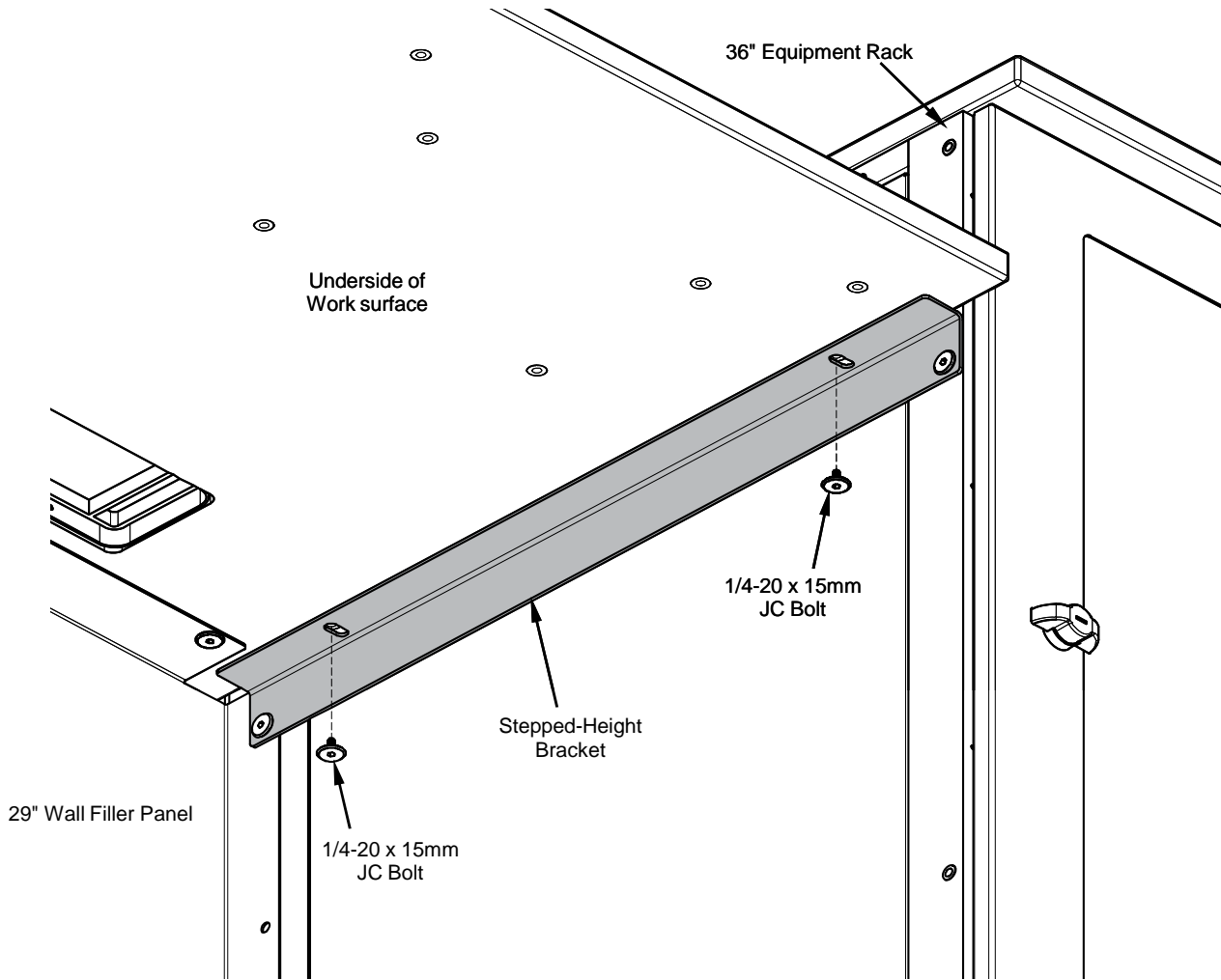

Figure 2

