

Technical Specifications



205 Westwood Ave, Long Branch, NJ 07740
Phone: 866-94 BOARDS (26273) / (732)-222-1511
Fax: (732)-222-7088 | E-mail: sales@touchboards.com

Connect36 - 55423

Connect18 - 55422

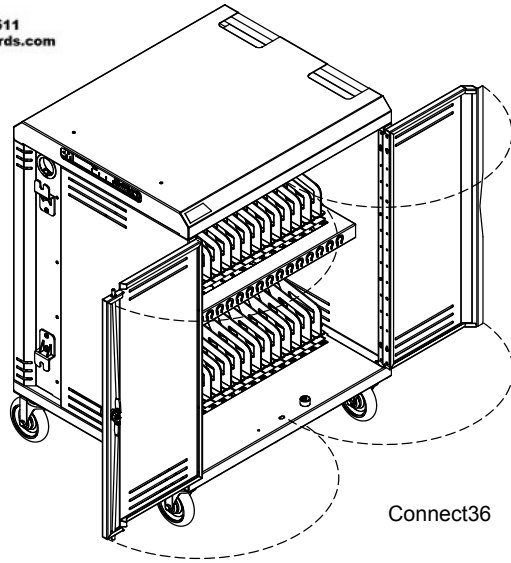
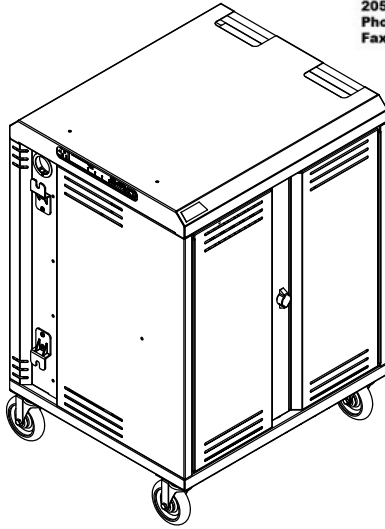

Connect36

Use the Connect36 / 18 Cart to store, transport, and charge up to 36 or 18 devices. Three charging options are available. Flexible dividers protect the devices. The overhead wire management aids the wiring integration and allows the charging plugs to hang in front of each device. The cart's compact footprint and top handles provide easy mobility. The economical Connect36 / 18 carts are made with heavy-gauge steel for security and powder-coated for a durable, long-lasting finish. Locking doors and panel increase notebook security.



Features and Benefits

- Stores, charges, and transports up to 36 or 18 devices (most Chromebooks, tablets*, and notebooks up to 15.6" diagonal)
- 1.3"W x 17.59"D x 13"H storage bay
- Numbered storage bays
- Small cart footprint (29"W x 25"D) saves valuable space
- Durable ABS plastic dividers protect devices from scratching (dividers are also removable to provide storage space for thicker devices)
- Recessed lock and cord wrap design eliminates damage through doorways
- Heavy gauge student-side doors feature a recessed dual-bolt steel lock with padlock hasp. (Padlock not included).
- Heavy gauge instructor-side panel has a recessed padlock hasp for security. (Padlock not included).
- Devices and students are separated from AC line voltage
- Superior, all-metal overhead cord management system keeps charge cords organized above each bay and make the Connect36 the fastest-to-wire cart in the industry
- Large wiring trays on power-side provide convenient power adapter wiring, storage, and wiring
- Ventilated doors and side panels keep devices and chargers cool, preventing overheating, and extending device life
- Replaceable, IEC (quick-release) 8' nominal 14 AWG, 3-wire power cord and external recessed cord wrap brackets provide easy power access
- Four inboard 5" balloon wheel plate casters (two locking, two non-locking) with metal construction and non-marring rubber provide easy rolling, and quiet transport (rated for 300 lb each)
- Integrated handles in top panel provides control and maneuverability
- Cart ships fully-assembled for quick, simple integration and deployment
- Durable powder coated steel chassis provides a long-lasting finish
- ETL recognized (certified to UL 60950-1) in the US and Canada for the cart and electrical system
- Warranted to be free of all defects in materials and workmanship for 10 years, electrical system 2 years
- Designed and assembled in Chippewa Falls, WI, USA

Connect36 available with:

- PowerProdigy™ charger that senses current from both power units and distributes power (up to 10A) to the least-charged devices first (where charging is needed most) ***For power adapters up to 65 watts**
- Power switch provides continuous power to both power units (non current-sensing) ***For power adapters up to 36 watts**
- Basic Timer provides cycling power to both power units (non current-sensing) ***For power adapters up to 65 watts**

- Horizontally adjustable, (125V~/12A, 60Hz) universal power units work with most inline adapters (36 or 18 outlets)
- External power switch provides easy-access for safe power connection / disconnection
- External LED illumination on timers indicate charge status while doors are closed

Connect36

- 55423-DBQ - PowerProdigy™ charger
- 55423-DBR - Power Switch
- 55423-DBT - Basic Timer

(Holds up to 36 devices)

Connect18

- 55422-DBR - Power Switch

(Holds up to 18 devices)

Color Options

Metal:
Dark Gray



*Accessory power plug may be needed

Construction

- 16-gauge top cover
- 20-gauge doors, side panels, power-side panel, and base
- All metal components are finished with a scratch-resistant powder coat epoxy
- ABS plastic dividers
- This cart is factory-assembled, packaged, and shipped on its side

Specifications

Capacity	36 / 18 devices. (Most Chromebooks, tablets*, or notebooks) *Accessory power plug may be needed	
Storage bays (nominal)	1.3"W [3.3 cm] x 17.59"D [44.7 cm] x 13"H [33 cm]	
Electrical	<ul style="list-style-type: none"> • 18-outlet power units (Two on Connect36, one on Connect18) • 125V~/12A, 60Hz • 15-amp breaker • IEC quick-release (replaceable) 8' nominal, 14 AWG, 3-wire power cord 	<ul style="list-style-type: none"> • Locking power-side panel isolates and separates electrical line voltage from students • ETL recognized (certified to 60950-1)
Charging options (See p.4 for specs)	<p>⚠ Note: The customer should be aware of the amp draw of the devices used with this cart-especially when maxing out the storage and charging capacity. Exceeding 15 amps will trip the circuit breaker. Please consult the owners manual of your specific device for power consumption information.</p>	
5" Balloon Wheels	Weight capacity 300 lb [136.2 kg] each (two locking, two non-locking)	
Certifications / Compliance	<ul style="list-style-type: none"> • ETL recognized • TAA compliant 	<ul style="list-style-type: none"> • Meets or exceeds applicable ANSI-BIFMA test standards
Unit weight (nominal)	132 lb [60 kg]	
Shipping weight (nominal)	180 lb [81.7 kg]	

Specifications subject to change without notice

Numbered storage bays

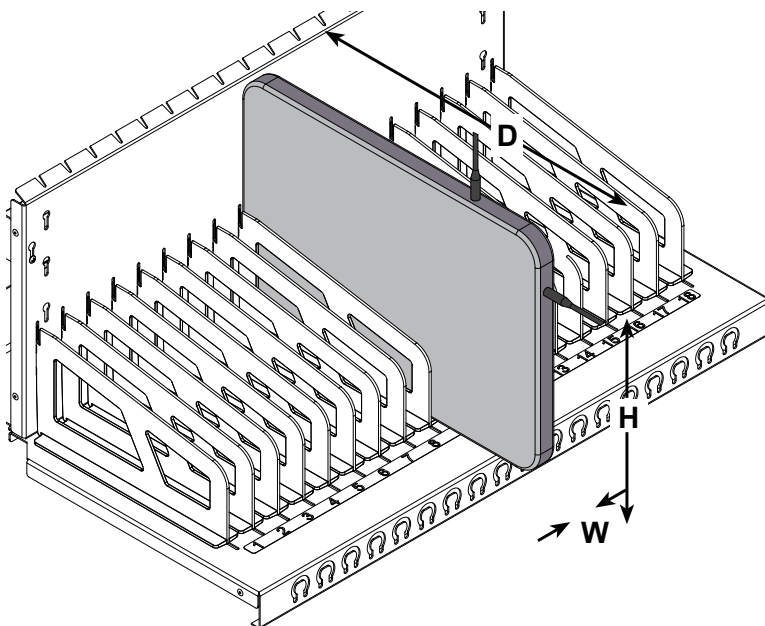

Devices must be placed in the bays with the charge plug on one of the two exposed edges shown.

5" Balloon Wheel

Note: (2) locking, and (2) non-locking casters are included on each unit.

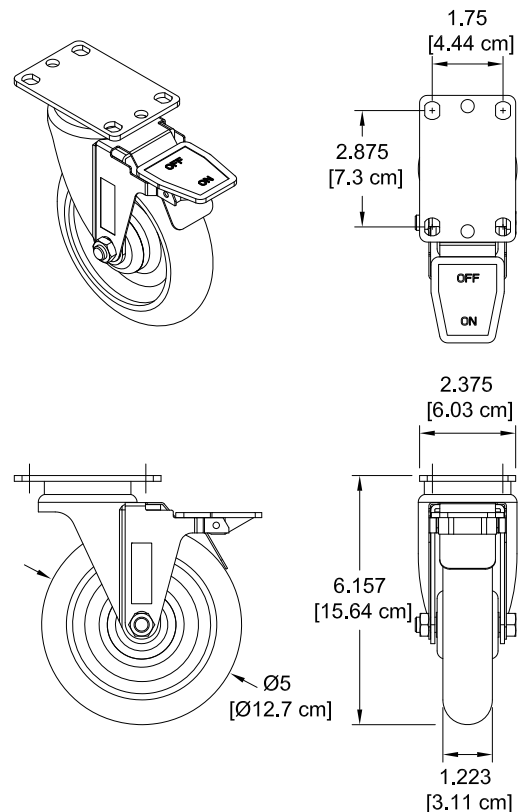

Device-side locking doors

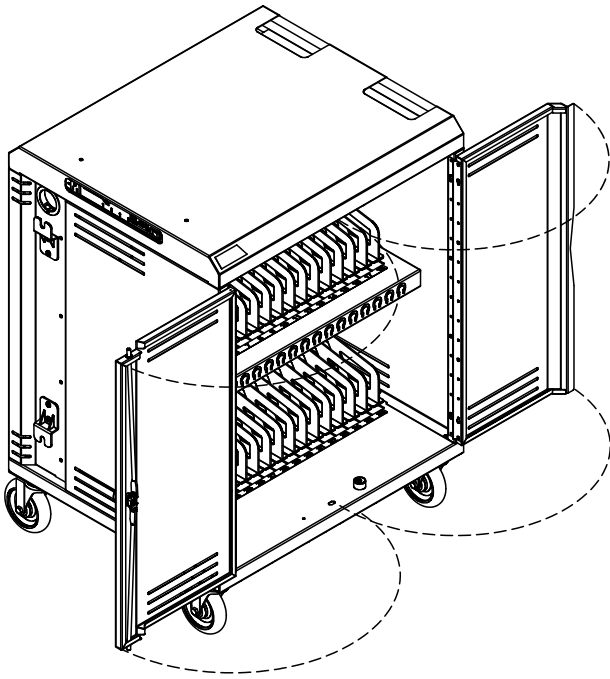

Connect18
(open lower shelf)

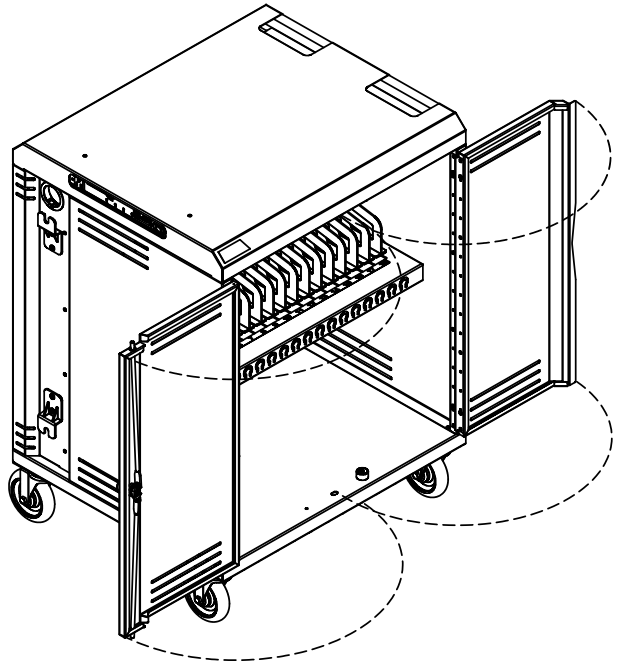

Device-side doors

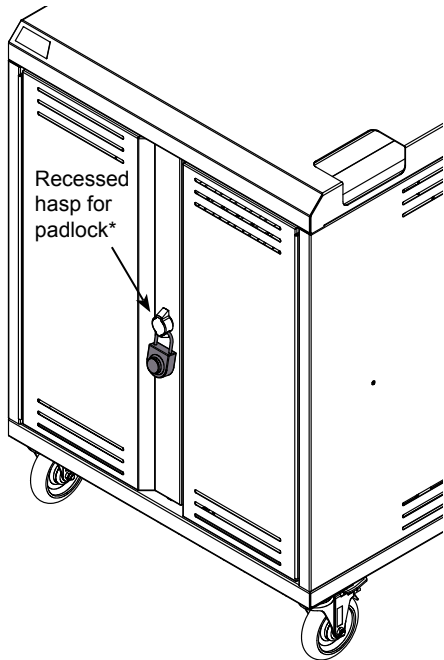

Recessed
hasp for
padlock*

Power-side locking access panel

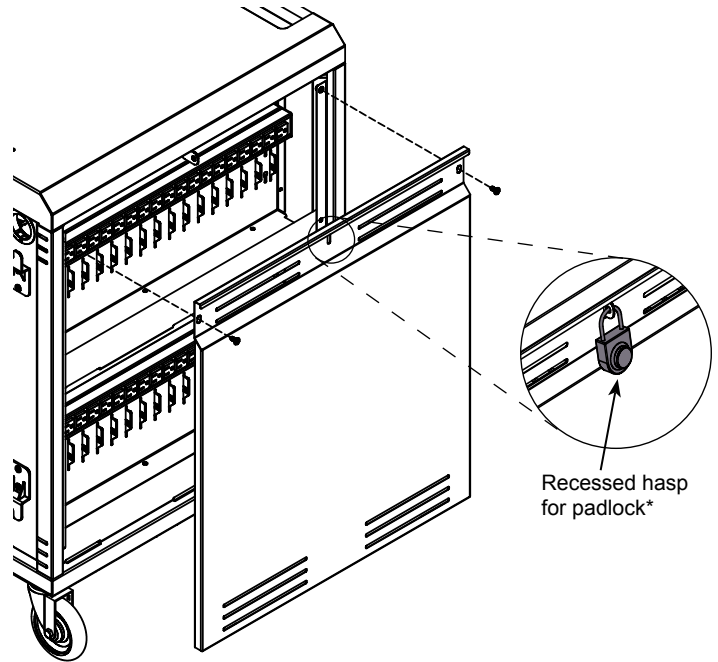

Recessed hasp
for padlock*

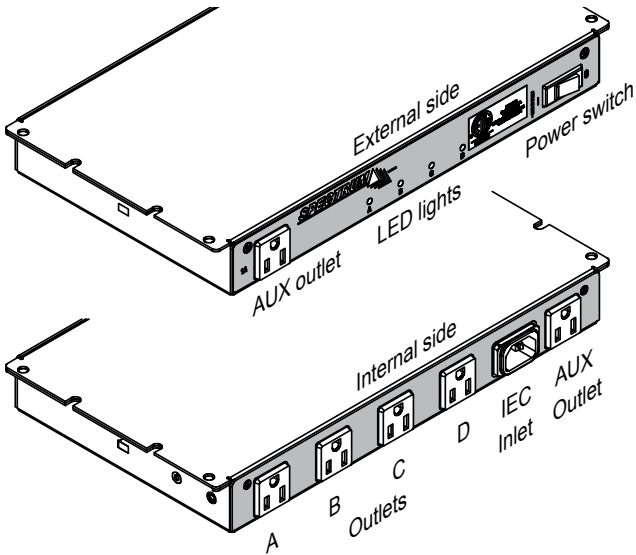

PowerProdigy™ Charger (Q)

Use with higher amp-draw devices. On a fully-loaded Connect36 Cart, the PowerProdigy™ Charger can be used with most power adapters up to 65W.

- Smart charging senses current and distributes power to the power units requiring it most
- Four green LED lights indicate charging activity status of each power unit
- Four timed power unit-dedicated outlets (labeled A, B, C, D) controlled by logic board
- Two auxiliary outlets (1 external, 1 internal)
- ETL recognized (certified to 60950-1)

Input:	125V~/12A, 60Hz
Breaker:	15A, 250 VAC
Cycling interval:	15 minutes
Cycling outlets:	4 timed (A, B, C, D) up to 10A
Auxiliary outlets:	1A each (controlled by main power switch)
Power Cord:	IEC quick-release (replaceable) 8' nominal, 14 AWG, 3-wire
Power switch:	15A (externally accessible)

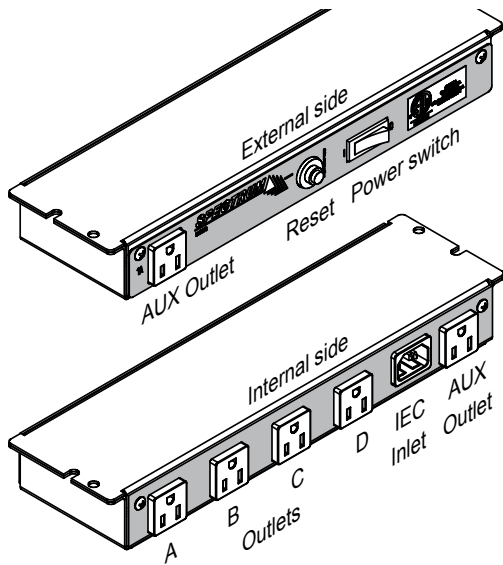

Power Switch (R)

The Power Switch provides continuous power to all power units. Use with lower amp-draw devices. On a fully-loaded Connect36 Cart, the Power Switch can be used with most power adapters up to 36W.

- Four continuous power-unit dedicated outlets (labeled A, B, C, D)
- Two auxiliary outlets (1 external, 1 internal)
- ETL recognized (certified to 60950-1)

Input:	125V~/12A, 60Hz
Breaker:	15A, 250 VAC
Outlets:	4 timed (A, B, C, D) up to 10A
Auxiliary outlets:	1A each (controlled by main power switch)
Power Cord:	IEC quick-release (replaceable) 8' nominal, 14 AWG, 3-wire
Power switch:	15A (externally accessible)

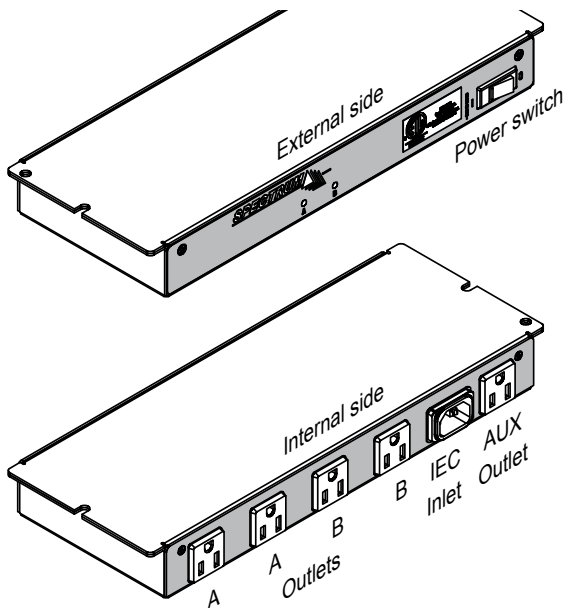

Basic Timer (T)

The Basic Timer charges one half of the devices for 15 minutes, then charges the second half of the devices for another 15 minutes. This cycling occurs automatically and is not adjustable. On a fully-loaded Connect36 Cart, the Basic Timer can be used with most power adapters up to 65W.

- Two timed power-unit dedicated outlets (labeled A, B) (up to 10A power output)
- Two green LED lights indicate charging activity status of each power unit
- One auxiliary outlet (external)
- ETL recognized (certified to 60950-1)

Input:	125V~/12A, 60Hz
Breaker:	15A, 250 VAC
Cycling interval:	15 minutes
Cycling outlets:	4 timed (A, B) up to 10A
Auxiliary outlet:	1A (controlled by main power switch)
Power Cord:	IEC quick-release (replaceable) 8' nominal, 14 AWG, 3-wire
Power switch:	15A (externally accessible)

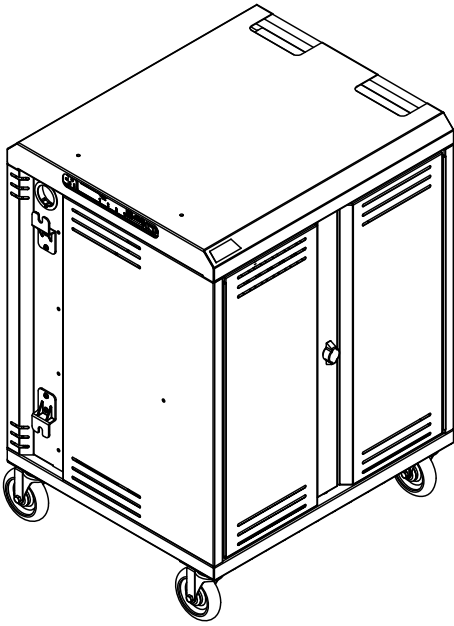

Power-side panel with hasp

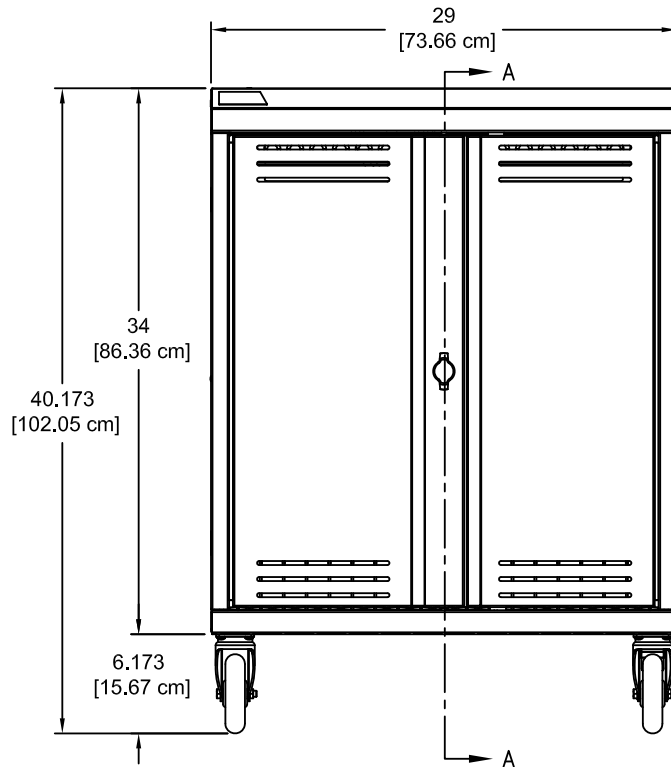
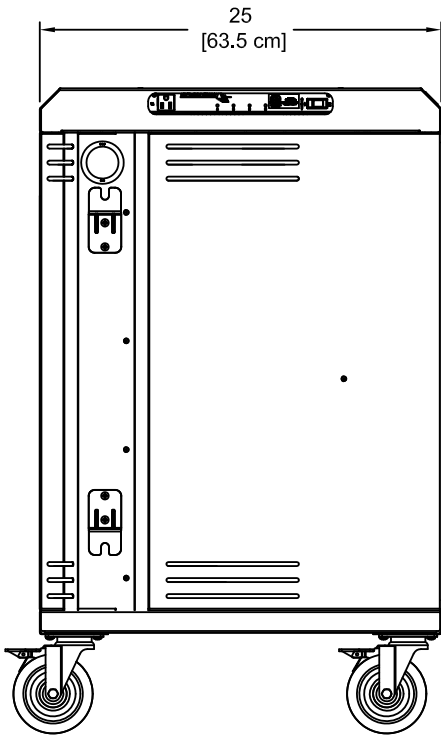
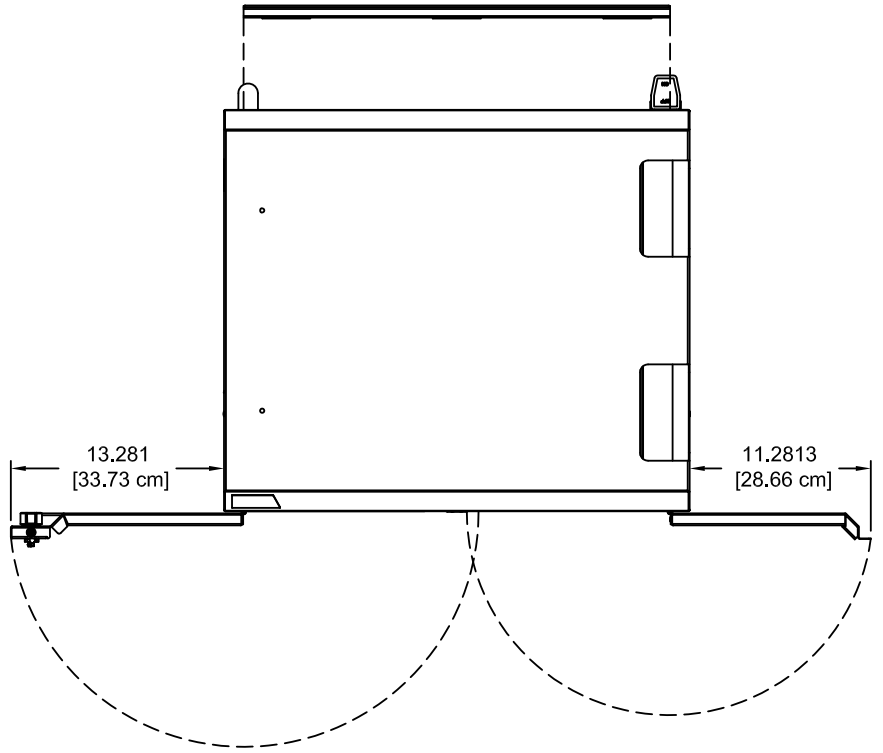

Connect36
Section view A-A

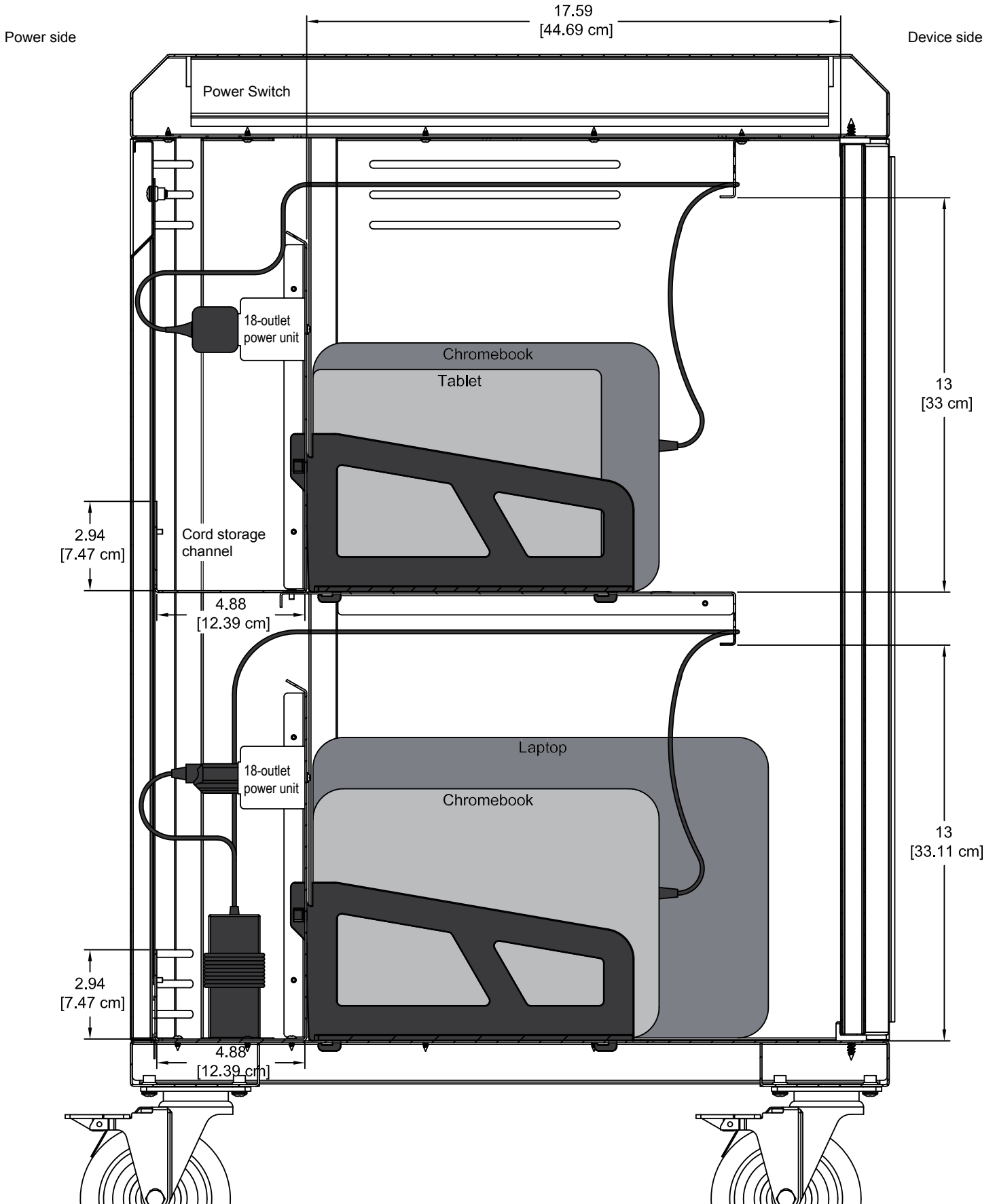

Connect36
Device side view wiring diagram
(shown with doors open)

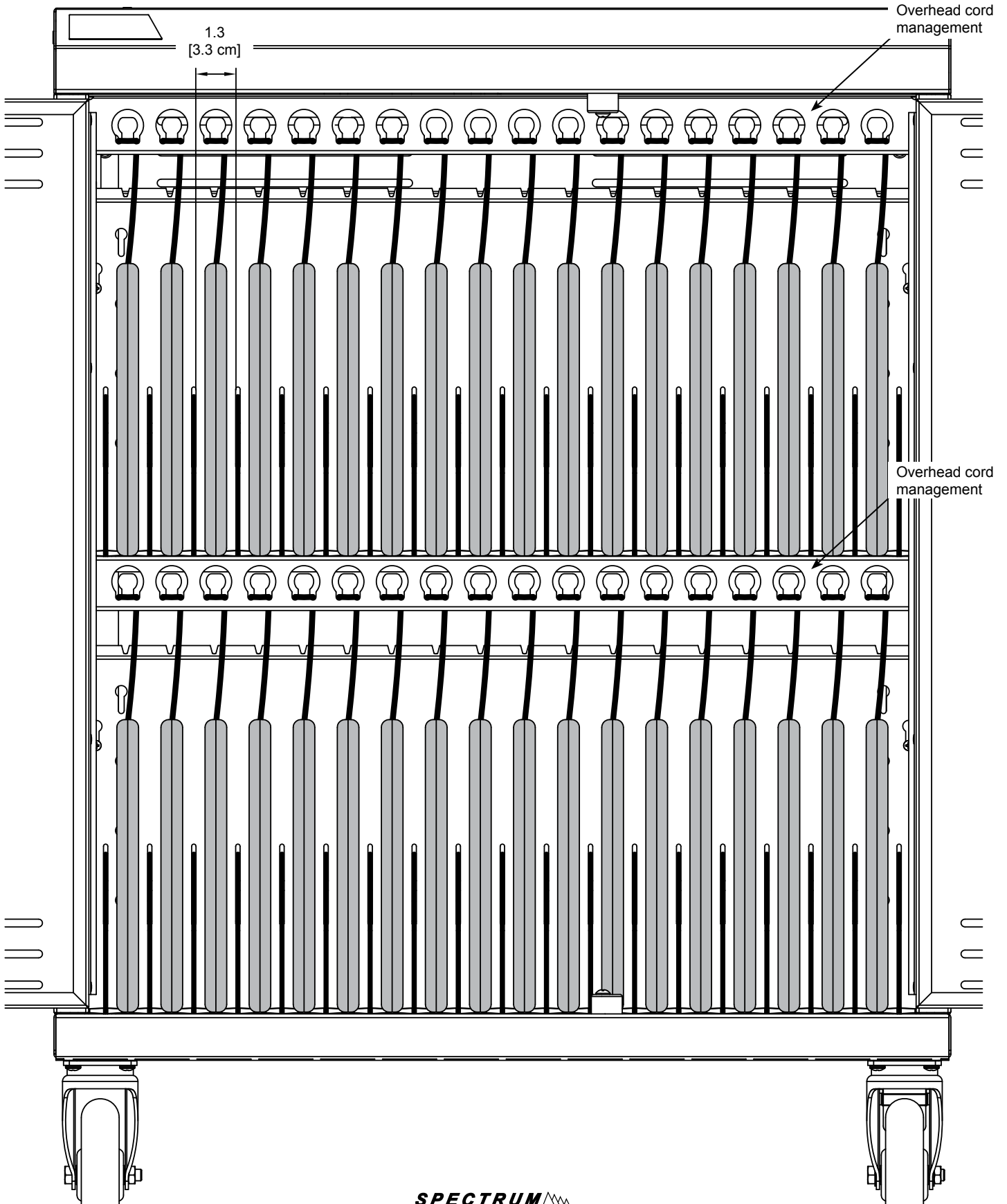

Connect36
Power side wiring diagram
(shown without locking panel)

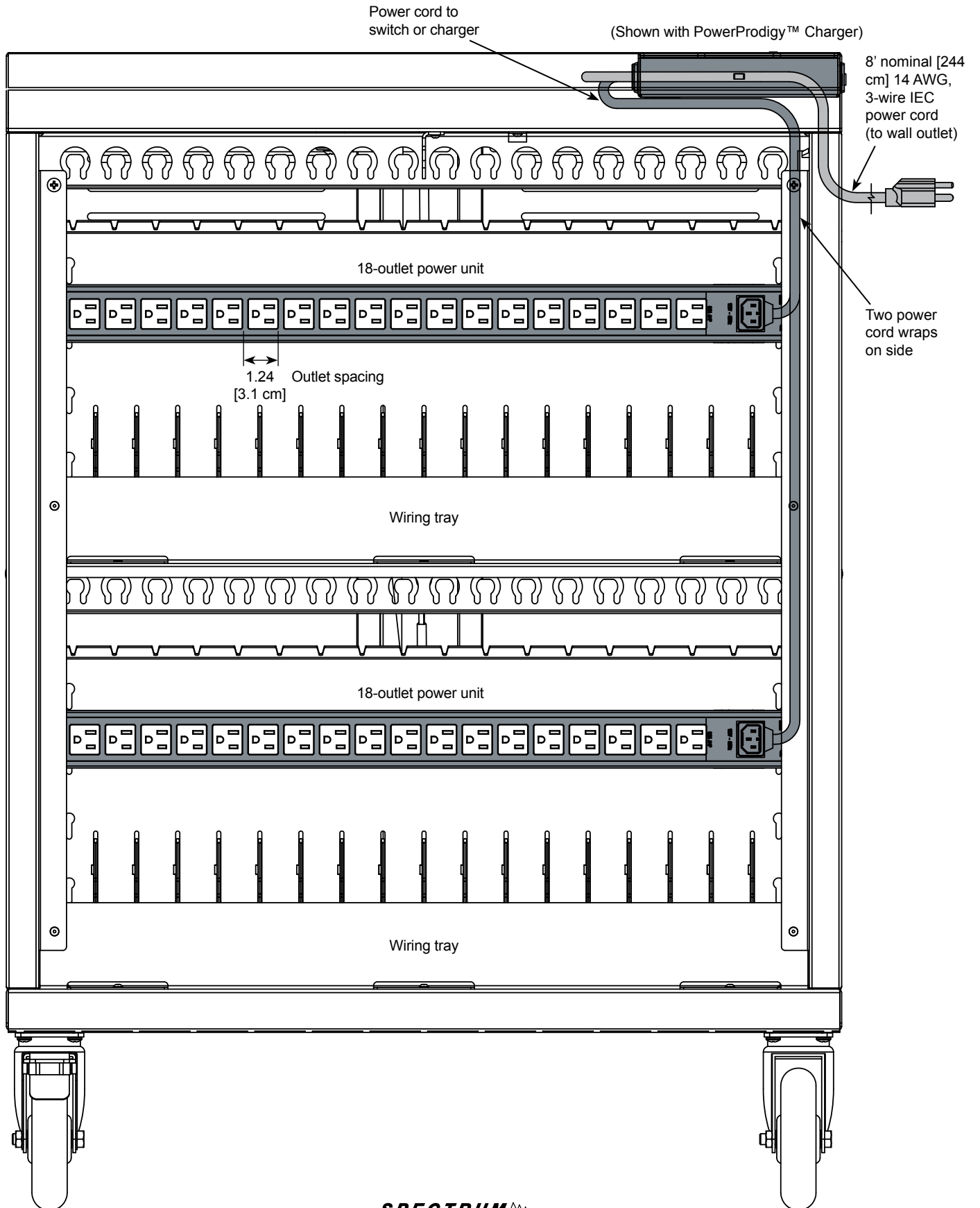

Accessories



Hook-and-loop Strap Kit - 95004

(16) .75" [1.91 cm] x 12" [30.48 cm],
and (32) .75" [1.91 cm] x 5" [12.7 cm]

Touchboards

205 Westwood Ave, Long Branch, NJ 07740
Phone: 866-94 BOARDS (26273) / (732)-222-1511
Fax: (732)-222-7088 | E-mail: sales@touchboards.com

Warranty

WE WILL MAKE IT RIGHT FOR YOU!

Spectrum is committed to provide complete customer satisfaction. Each of our products is manufactured from the best materials available and each product is stringently monitored throughout the production process through our P.A.C.E. program (Product Assurance to meet Customer Expectations).

We expressly warrant that Spectrum products will be of good quality and workmanship and free from defect for the period set out in the warranty table below from the date of delivery. This warranty shall not apply to defects or damage resulting from misuse, abuse, neglect, improper care, modification or repair not authorized by Spectrum, or any other cause outside the control of Spectrum. Spectrum will, at its sole option, either repair or replace the defective product.

This warranty is exclusive; no other warranty, written or oral, is expressed or implied. This warranty is given by Spectrum to Buyer and to no other person or legal entity. No Spectrum dealer, distributor, agent or employee is authorized to make any modification or addition to this warranty.

NOTWITHSTANDING ANYTHING TO THE CONTRARY, SPECTRUM WILL NOT UNDER ANY CIRCUMSTANCES BE LIABLE FOR INDIRECT OR LIQUIDATED DAMAGES, INCLUDING CONSEQUENTIAL, INCIDENTAL AND SPECIAL DAMAGES. IN NO EVENT SHALL SPECTRUM'S LIABILITY, WHETHER UNDER CONTRACT OR WARRANTY, IN TORT OR OTHERWISE, EXCEED THE PURCHASE PRICE RECEIVED BY SPECTRUM FOR THE PRODUCT AT ISSUE AND "RECALL ACTION" EXPENSES. SPECTRUM SHALL NOT BE SUBJECT TO ANY OTHER OBLIGATIONS OR LIABILITIES, WHETHER ARISING OUT OF BREACH OF CONTRACT, WARRANTY, TORT (INCLUDING NEGLIGENCE AND STRICT LIABILITY) OR OTHER THEORIES OF LAW, WITH RESPECT TO PRODUCTS SOLD OR SERVICES RENDERED BY SPECTRUM, OR ANY UNDERTAKINGS, ACTS OR OMISSIONS RELATING THERETO.

Our Customer Service Department is ready to provide immediate attention to any questions, comments or concerns. They are available to answer your calls Monday through Friday from 7 am to 5 pm CST. In addition your product comments or concerns are welcome via e-mail at: spectrum@spectrumfurniture.com.

Warranty Table

Item	Warranty Period effective 1/1/2015
Adjustable Crank / Electric Desk Legs	• 1 Year
Flat Panel Desk Gas Cylinders	
Chairs <ul style="list-style-type: none"> • Adjustable Height Chair Parts – including frames, gas cylinders, wood and plastic parts, control handles, casters • Adjustable Height Chair Upholstery • In-Stock Upholstery • Graded-In Fabrics and Customer Owned Material 	<ul style="list-style-type: none"> • 7 Years • 2 Years • 2 Years • No Warranty
Height Adjustable Columns and Lifts	• 1 Year
General Use Casters	
Electrical (including timers and LINAK actuators)	• 2 Years
Keyboard / Mouse Trays	• 1 Year
Flat Panel Monitor Arms <ul style="list-style-type: none"> • Flat Panel Monitor Arm – General Parts • Flat Panel Monitor Arm – Gas Cylinders 	<ul style="list-style-type: none"> • 5 Years • 2 Years
Desks and Lecterns <ul style="list-style-type: none"> • Computer Desk Chassis • Cart Chassis • Lectern Chassis 	• 10 Years

