

Flex Insight Desk™

38955	36" single desk
38957	72" double desk
38956	42" single desk with ADA clearance

38958	36" single desk with lock
38960	72" double desk with lock
38959	42" single desk with ADA clearance and lock

Touchboards

205 Westwood Ave, Long Branch, NJ 07740
Phone: 866-94 BOARDS (26273) / (732)-222-1511
Fax: (732)-222-7088 | E-mail: sales@touchboards.com

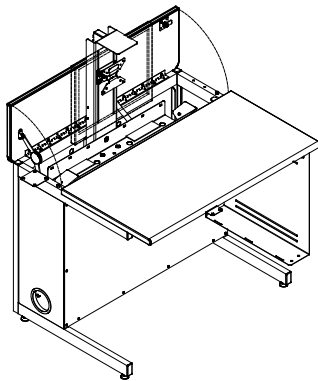

36" single desk

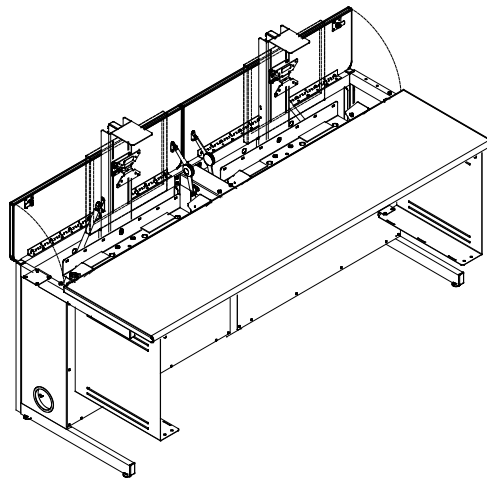

72" double desk

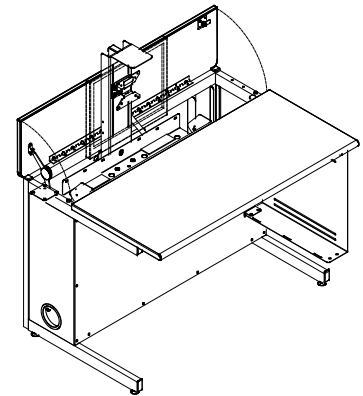

42" single desk with ADA clearance

⚠ Important ⚠

Before using this product:

- Read this manual
- Comply with all safety and operating instructions
- Ensure all parts and correct quantities are included

Any parts damaged during shipment must be reported within 15 days of receipt. To report information regarding missing parts or damage, to purchase parts or accessories, or if you have any questions, please contact us.

Thank you for purchasing Spectrum products!

Spectrum Industries, Inc
925 First Avenue, Chippewa Falls, WI 54729 USA
800 235 1262
715 723 6750
www.spectrumfurniture.com

⚠ Important Safety and Care Instructions ⚠

- Read this owner's manual before assembly or operation.
- Do not allow children to move the table.
- For indoor use only. Do not install or store the table where it will be exposed to moisture.
- Do not block the ventilation openings.
- Do not allow anyone to sit, stand, or climb on the table.
- Use a damp, soft-cloth, or sponge, with mild soap or detergent solution to clean dirty surfaces. Do not use harsh solvents or abrasives.
- This table is intended for institutional use. It does not have any user-serviceable parts or user-maintenance requirements. If servicing is necessary, please contact Spectrum Industries for assistance.

⚠ Warning - Relocating audio and/or video equipment to furniture not specifically designed to support audio and/or video equipment may result in death or serious injury due to the furnishing collapsing or over turning onto a child.

⚠ Warning - Death or serious injury may occur when children climb on audio and/or video equipment furniture. A remote control or toys placed on the furnishing may encourage a child to climb on the furnishing and as a result the furnishing may tip over on to the child.

Electrical Safety:

- Keep the power switch in the OFF position before plugging or unplugging from the wall outlet.
- Ensure total device / equipment load does not exceed 12-amps.
- Do not plug the power cord into an extension cord.
- Inspect the power cords for damage before each use. Do not use power cords that are damaged.
- Unplug power cord from electrical outlet by gripping the cord. Do not unplug the power cord by pulling only on the cord.
- Do not step on, drive over, drag, or place objects on the power cord.
- For added safety, plug the cart into a grounded outlet controlled by a GFI (Ground Fault Interrupter) circuit breaker.
- Damaged electrical components can create significant hazards to users and is not covered by the warranty. Repairs should always be performed by a qualified electrician.
- Electrical devices are not toys. Children are often unaware of the hazards associated with electrical devices. This table must always be used by adults or with adult supervision.

Hardware

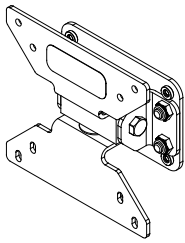

Standard Swivel VESA Monitor Mount with internal travel stops provides 4-direction tilt, and works with 75mm and 100mm VESA monitor mounts (includes mounting screws)

- (1) 0107624 with single desks
- (2) 0107624 with double desks



0102376
11" zip ties
(10) with single desks
(15) with double desks



(4) 025068
5/16-18 glides



(4) 052605
1/4-20 x 15mm
JC bolts

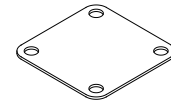

(1) 0107574
unit-to-unit
bracket



(1) 025039
4mm hex wrench

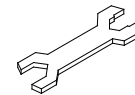

(1) 025069
glide wrench

Assembly / Setup

1. Unlock monitor column



Note: Every Flex Insight desk ships with one or two carriage bolts with wing nuts locked in a keyhole slot under the bottom of the keyboard tray. These fasteners prevent monitor column movement during shipping, and will need to be removed to get the monitor column to function. A picture of the bolt and wing nut is shown here from the back side of the desk. To remove, unscrew the wing nut by hand, and slip the bolt out of the keyhole slot. The fasteners should be retained for reuse if you will be transporting the desk.

If you transport the desk (in a trailer or truck) it is recommended to replace the carriage bolt and wing nut. To replace, start the wing nut on the end of the bolt and push the monitor column down into the lowered position. Wiggle the head of the bolt into the slot from the large side of the keyhole. Let the monitor column rise slightly to put tension on the wing nut. Tighten down until monitor column does not move and is secure.

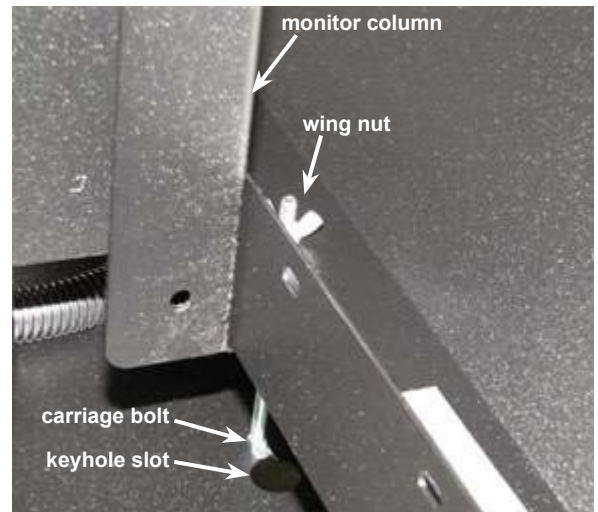

Figure 1

2. Install glides

1. Carefully lift one side of the desk and place a short wooden 4x4 or 2x4 block (or equivalent support) under the leg. This may require two people. **Figure 2.**
2. Thread the two glides into the leg, tighten securely, and remove block.
3. Repeat this procedure on the other side of the desk.
4. The glides can be adjusted with the included glide wrench to level the desk if necessary.

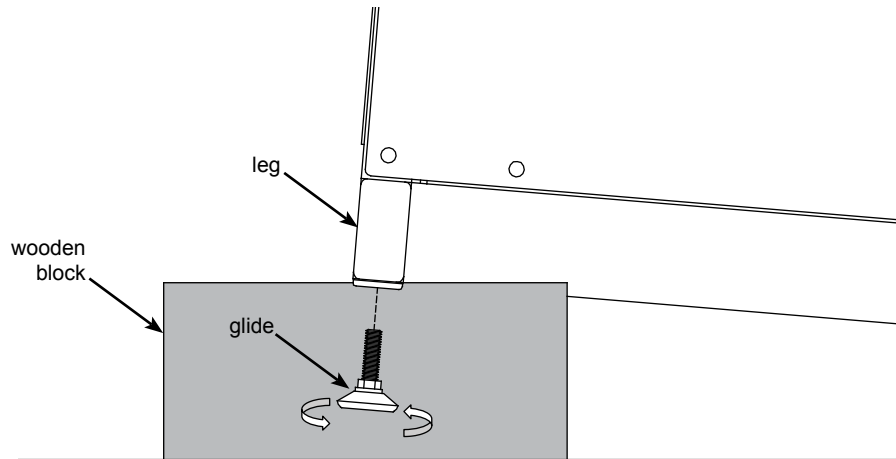
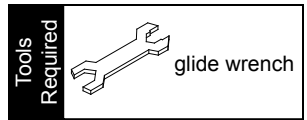

Figure 2

3. Connecting desks together (optional)

1. Desks of equal height can be connected together with the included unit-to-unit bracket. **Figure 3.**
2. Align desks next to each other in their final location and raise monitor compartment lids.
3. Attach desks together with a unit-to-unit bracket and (4) 1/4-20 x 15mm JC bolts. Tighten bolts securely.
4. Disconnect brackets to move/relocate desks.

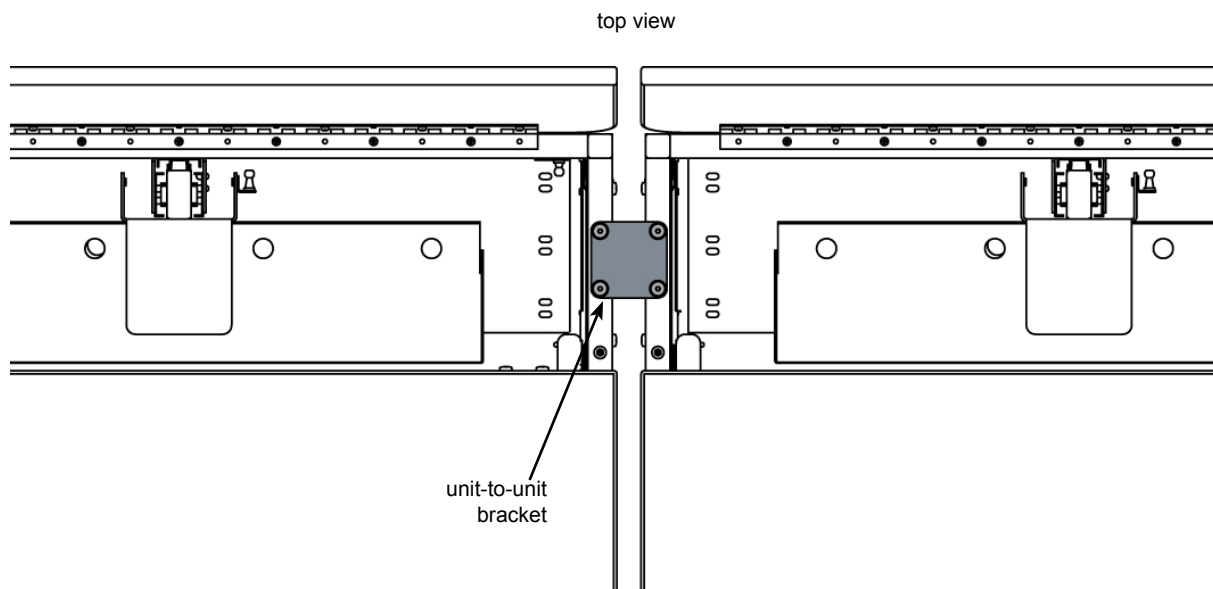
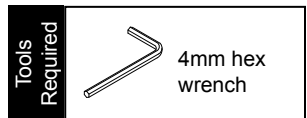

Figure 3

4. Monitor installation

1. Attach the VESA mount (butterfly-shaped portion) to the back of your flat panel monitor with (4) M4 x 12mm PHM screws. (Holes on top, slots on bottom). **Figure 4A.** Note: On most flat panel monitors, it will be necessary to remove the standard base that comes with the monitor to use the VESA mounting option.
2. Thread (2) 10-24 x 1/2" SHC screws into the upper rectangular plate at the back of the VESA mount-leave about 1/8" between the screw head and plate.

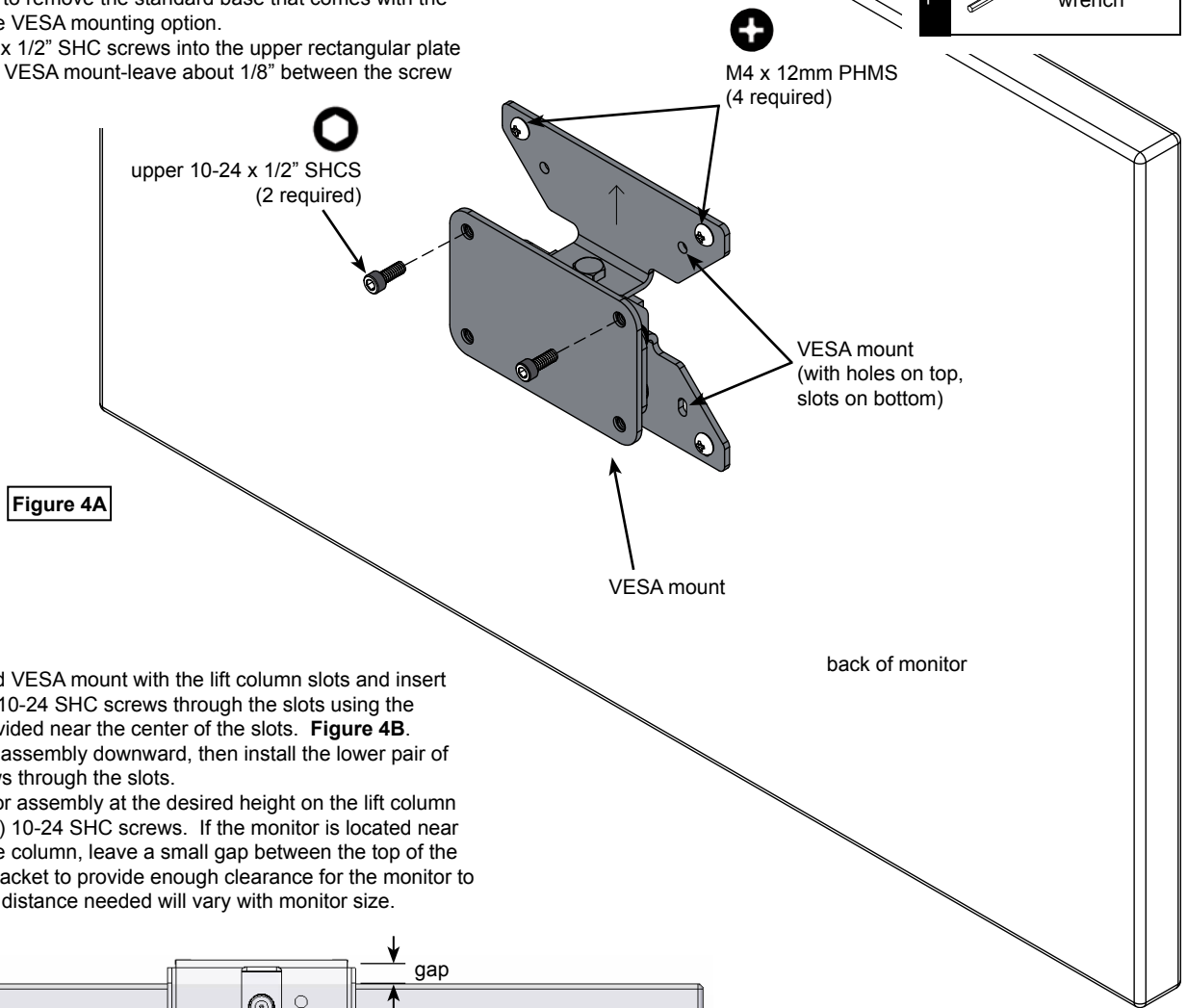

Figure 4A

3. Align the attached VESA mount with the lift column slots and insert the upper pair of 10-24 SHC screws through the slots using the access holes provided near the center of the slots. **Figure 4B.**
4. Slide the monitor assembly downward, then install the lower pair of 10-24 SHC screws through the slots.
5. Locate the monitor assembly at the desired height on the lift column then tighten all (4) 10-24 SHC screws. If the monitor is located near the very top of the column, leave a small gap between the top of the monitor and lift bracket to provide enough clearance for the monitor to fully tilt. The gap distance needed will vary with monitor size.

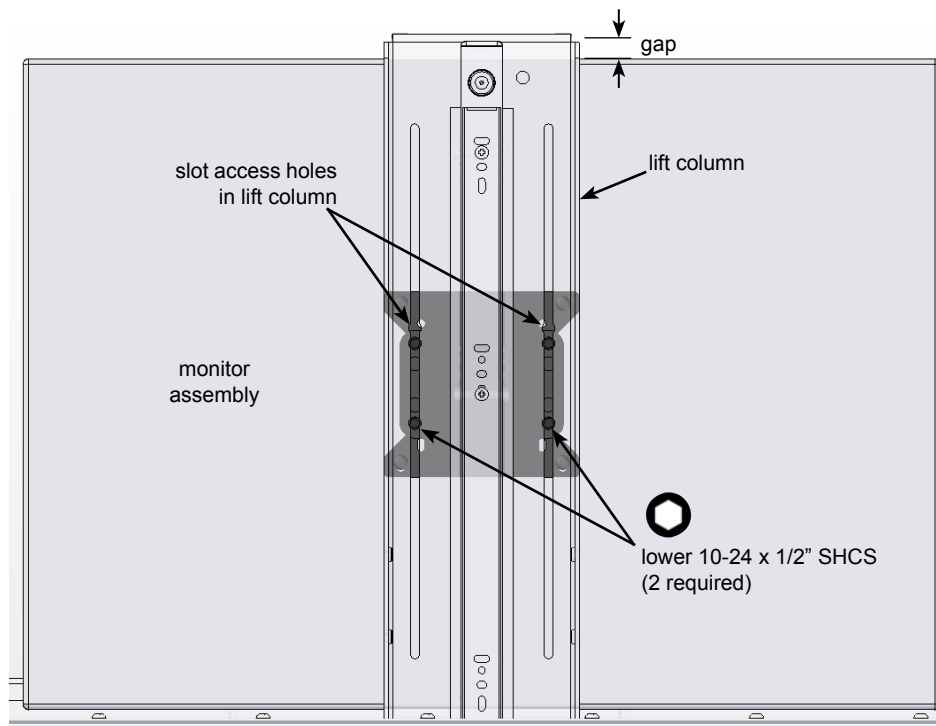

Figure 4B

5. CPU installation

1. Set the CPU unit into the CPU sling.
2. Make sure the CPU will be supported by both straps. Tighten the straps around the CPU while keeping the buckles positioned as high as possible to avoid interference. **Figure 5A.**

Note: The center slot can be used for better support of smaller profile CPU's. If the center slot is necessary, take the rear strap out of the rear slot and thread into the center slot shown in **Figure 5A**. Thread the strap as shown in **Figure 5B**.

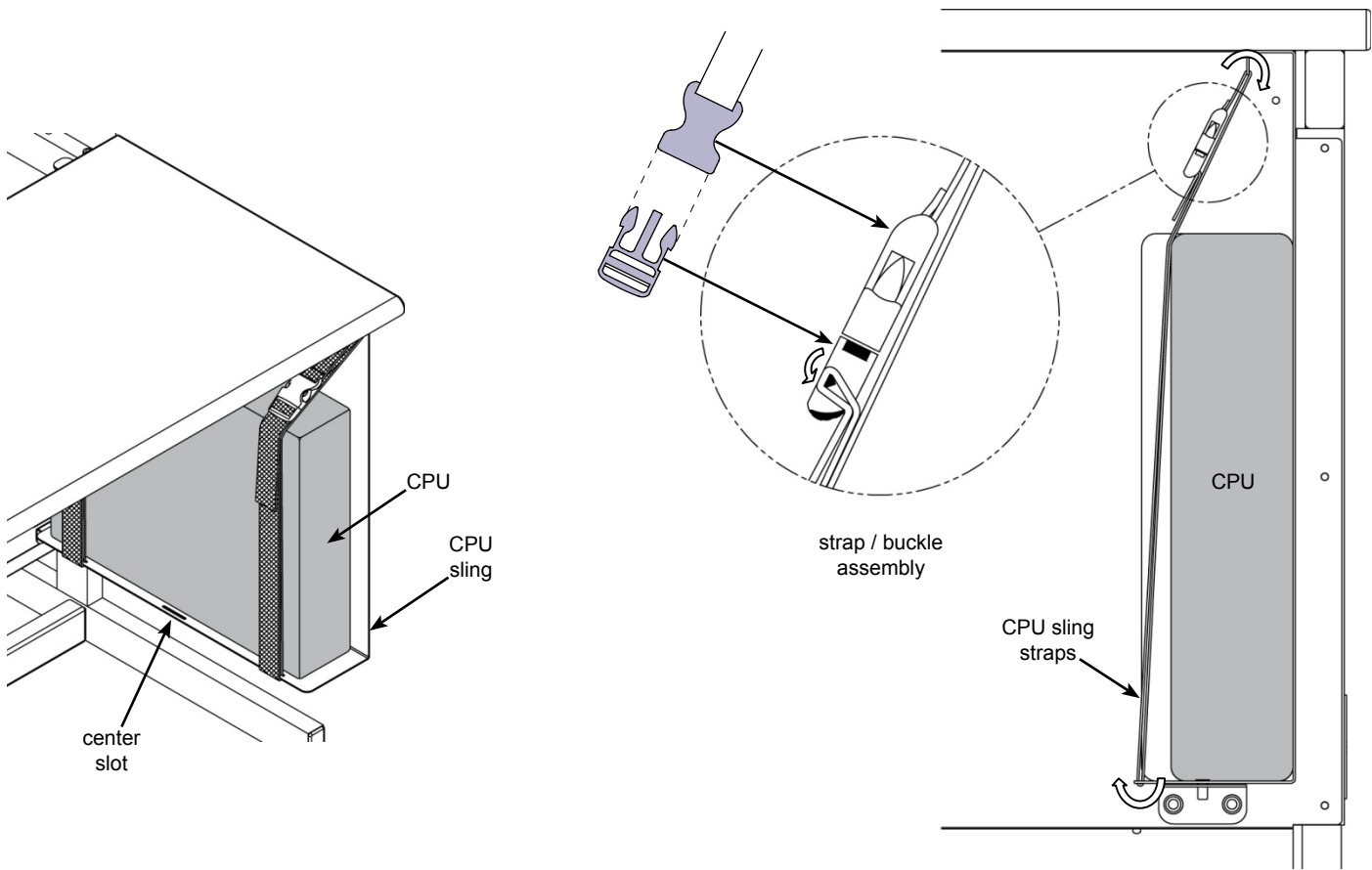
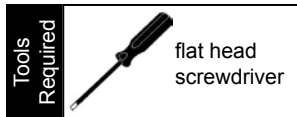

Figure 5A

Figure 5B

6. Cord management



1. With the back panel removed, connect the necessary monitor, keyboard, and mouse cords above the worksurface.
2. Position the keyboard as shown approximately 6" from the front edge of the worksurface with the mouse on the opposite side of the CPU as shown. **Figure 6A**. This will provide enough slack in the cords during normal use and provide for left and right mouse locations. With zip ties, secure cords to the back of the keyboard tray as shown.
3. The wire loom keeps monitor and keyboard cords together and routes them while the monitor is being raised and lowered. Using a flat head screwdriver, pry open each loom clip to release the wire loom. **Figure 6B and 6C**.

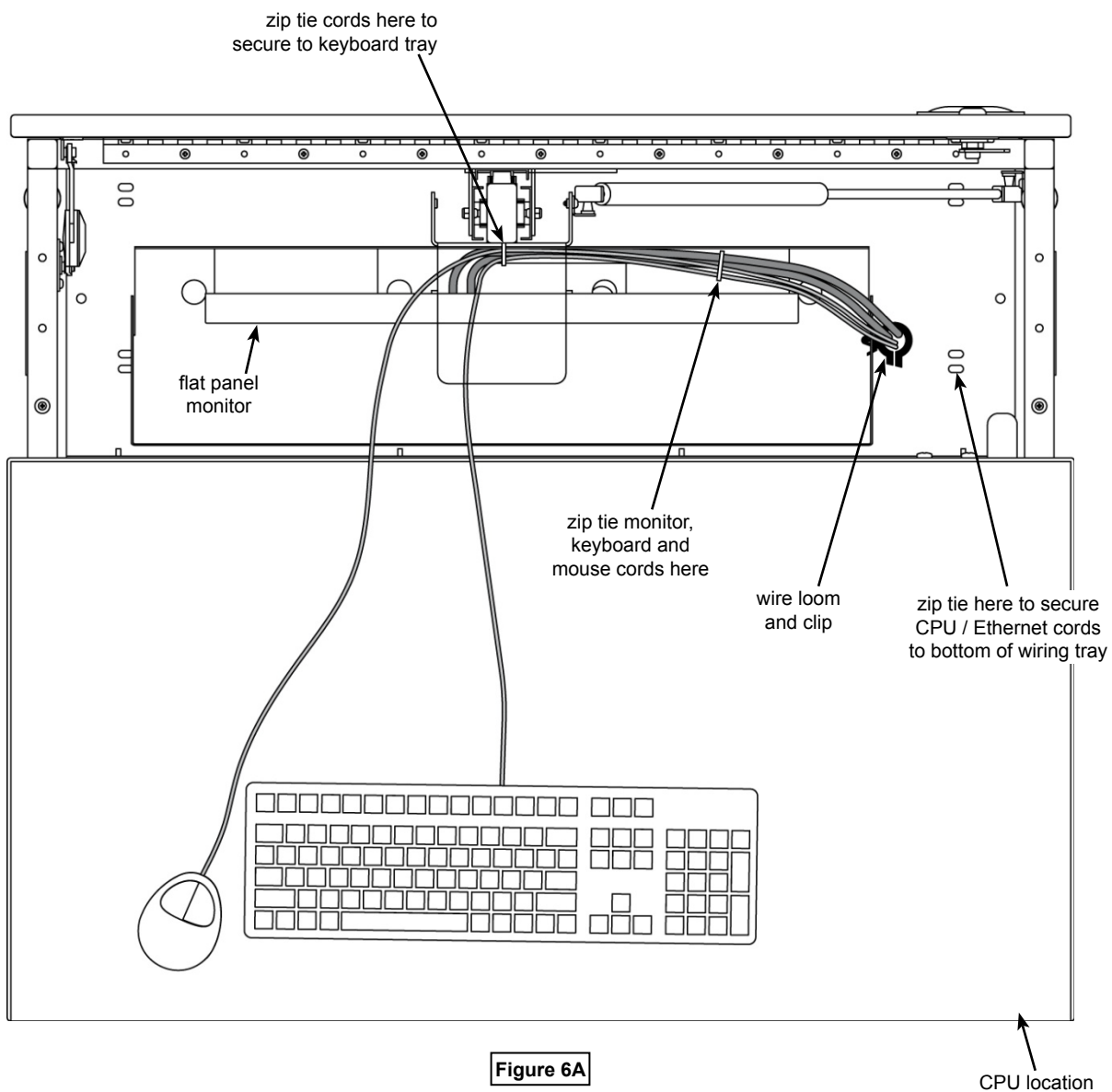

Figure 6A



Figure 6B



Figure 6C

4. With the loom removed, feed the monitor, keyboard, and mouse cords through the sliced opening of the loom to the bottom of the desk as shown. **Figure 6D.**
5. Split the CPU wires out of loom approximately 3/4 of the way down the loom and plug into the CPU.
6. Reattach the loom with the clips while providing enough slack in the loom to allow the monitor column to fully extend and retract.
7. Secure the CPU cords to the bottom of the loom by attaching a zip tie around the loom directly above where the CPU cords exit the loom. This will prevent the cords from backing out. **Figure 6D.**
8. Secure the CPU / Ethernet cords to the bottom of the wiring tray with a zip tie.
9. Use zip ties to secure additional cords as needed.

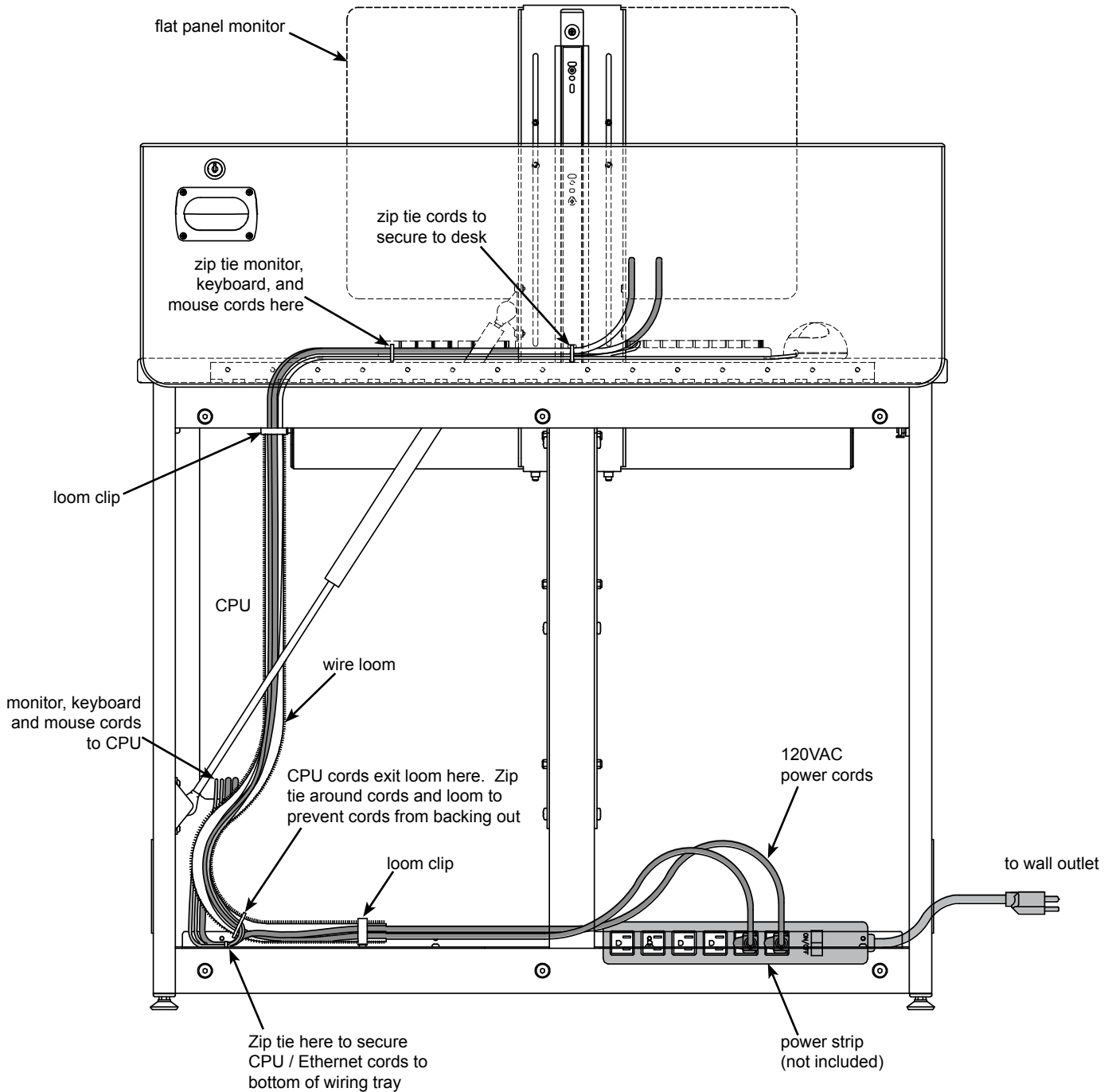

Figure 6D

Operation

For computer use:

1. Open the monitor compartment lid.
2. Raise the monitor by pulling up on the lift bracket until fully extended.
3. Take out the keyboard and mouse and set on the worksurface.



For classroom (worksurface) use:

1. Place the keyboard and mouse in the compartment tray under the monitor.
2. Lower the monitor by pushing down on the lift bracket until the column is fully retracted, then close the monitor compartment lid. Lockable desks can be locked at this point for security.

Maintenance

After approximately 300 cycles of opening and closing, the friction dampener on the worksurface lid should be retightened to 13 in-lbs using a torque wrench with a 4mm hex driver. If a torque wrench is unavailable, tighten the friction damper with a 4mm hex wrench 1/8 turn at a time and test. The correct adjustment is when the lid slows down between 2-4" from closure.

Figure 7.

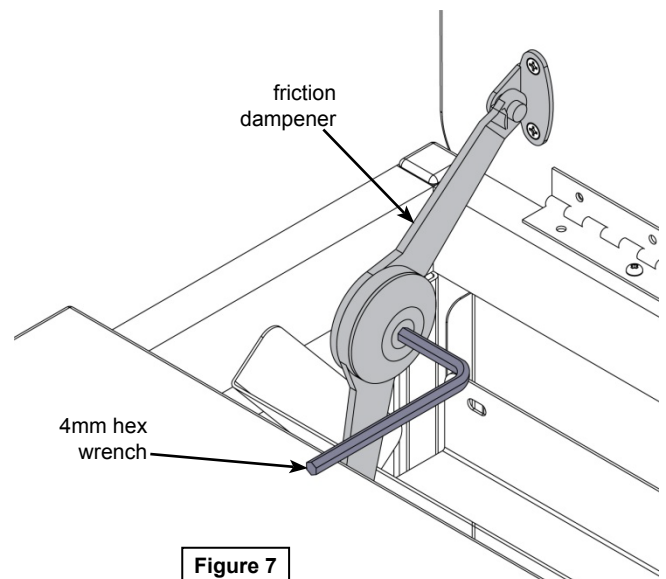
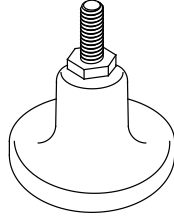

Figure 7

Options



1" Bell Glide Riser Kit
raises worksurface height from
29" to 30" (set of 4)
98513

EP8 Kits and Accessories

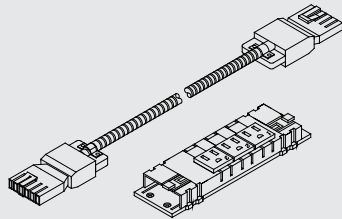

EP8 Kit for 30" Desk - 99014
36" Desk - 99008
44" Desk - 99009
48" Desk - 99018
60" Desk - 99010
72" Desk - 99011
Corner Printer - 99012
Center Printer - 99013

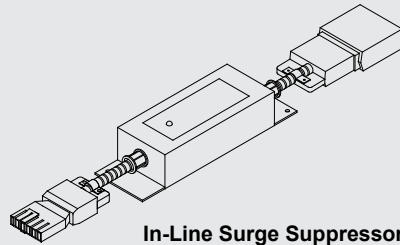

In-Line Surge Suppressor
99016

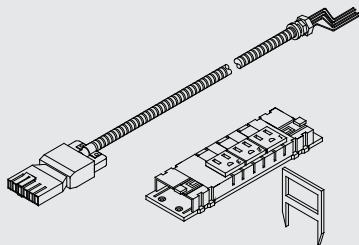

Base Power Feed
with 36" flexible cord
99022

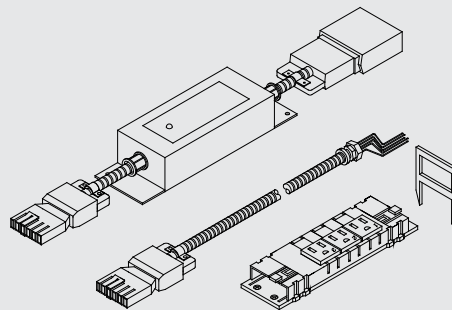

Starter Surge Suppressor
with 12' pigtail cable
99017

Warranty

WE WILL MAKE IT RIGHT FOR YOU!

Spectrum is committed to provide complete customer satisfaction. Each of our products is manufactured from the best materials available and each product is stringently monitored throughout the production process through our P.A.C.E. program (Product Assurance to meet Customer Expectations).

We expressly warrant that Spectrum products will be of good quality and workmanship and free from defect for the period set out in the warranty table below from the date of delivery. This warranty shall not apply to defects or damage resulting from misuse, abuse, neglect, improper care, modification or repair not authorized by Spectrum, or any other cause outside the control of Spectrum. Spectrum will, at its sole option, either repair or replace the defective product.

This warranty is exclusive; no other warranty, written or oral, is expressed or implied. This warranty is given by Spectrum to Buyer and to no other person or legal entity. No Spectrum dealer, distributor, agent or employee is authorized to make any modification or addition to this warranty.

NOTWITHSTANDING ANYTHING TO THE CONTRARY, SPECTRUM WILL NOT UNDER ANY CIRCUMSTANCES BE LIABLE FOR INDIRECT OR LIQUIDATED DAMAGES, INCLUDING CONSEQUENTIAL, INCIDENTAL AND SPECIAL DAMAGES. IN NO EVENT SHALL SPECTRUM'S LIABILITY, WHETHER UNDER CONTRACT OR WARRANTY, IN TORT OR OTHERWISE, EXCEED THE PURCHASE PRICE RECEIVED BY SPECTRUM FOR THE PRODUCT AT ISSUE AND "RECALL ACTION" EXPENSES. SPECTRUM SHALL NOT BE SUBJECT TO ANY OTHER OBLIGATIONS OR LIABILITIES, WHETHER ARISING OUT OF BREACH OF CONTRACT, WARRANTY, TORT (INCLUDING NEGLIGENCE AND STRICT LIABILITY) OR OTHER THEORIES OF LAW, WITH RESPECT TO PRODUCTS SOLD OR SERVICES RENDERED BY SPECTRUM, OR ANY UNDERTAKINGS, ACTS OR OMISSIONS RELATING THERETO.

Our Customer Service Department is ready to provide immediate attention to any questions, comments or concerns. They are available to answer your calls Monday through Friday from 7 am to 5 pm CST. In addition your product comments or concerns are welcome via e-mail at: spectrum@spectrumfurniture.com.

Warranty Table

Item	Warranty Period
<ul style="list-style-type: none"> Adjustable Crank/Electric Desk Legs Flat Panel Desk Gas Cylinders 	<ul style="list-style-type: none"> 1 Year
<ul style="list-style-type: none"> Adjustable Height Chair Parts – including frames, gas cylinders, wood and plastic parts, and control handles Adjustable Height Chair Parts Casters Adjustable Height Chair Upholstery In-Stock Upholstery Graded-In Fabrics and Customer Owned Material 	<ul style="list-style-type: none"> 7 Years 2 Years 2 Years No Warranty
<ul style="list-style-type: none"> Height Adjustable Columns and Lifts General Use Casters Electrical Keyboard/Mouse Trays 	<ul style="list-style-type: none"> 1 Year
<ul style="list-style-type: none"> Flat Panel Monitor Arm – General Parts Flat Panel Monitor Arm – Gas Cylinders 	<ul style="list-style-type: none"> 5 Years 2 Years
<ul style="list-style-type: none"> Computer Desk Chassis Cart Chassis Lectern Chassis 	<ul style="list-style-type: none"> 10 Years



205 Westwood Ave, Long Branch, NJ 07740
 Phone: 866-94 BOARDS (26273) / (732)-222-1511
 Fax: (732)-222-7088 | E-mail: sales@touchboards.com



INDOOR ADVANTAGE GOLD
 FURNITURE

