

# Assembly Instructions

## ⚠ Important ⚠

Before you begin, read and comply with all safety and operating instructions, and ensure all parts and correct quantities are included.

Any parts damaged during shipment must be reported within 5 days of receipt. To report information regarding missing parts or damage, to purchase parts or accessories, or if you have any questions, please contact us.

[www.spectrumfurniture.com](http://www.spectrumfurniture.com)  
800-235-1262, 715-723-6750

Thank you for purchasing Spectrum products!



037779  
5/16-18 x 1" Glide

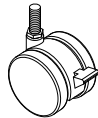

0101909  
2-3/8" Caster  
(with 5/16-18 stem)

Rectangular Flex Training Tables come with glides or casters in one of the following combinations:

4 Glides

2 Glides / 2 Casters

4 Casters

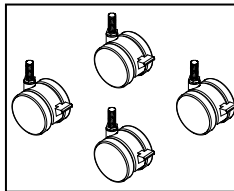
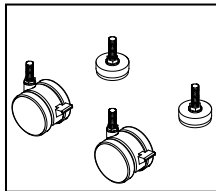
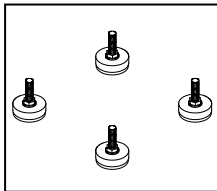

(20) 026064  
1/4-20 x 5/8" PHMS

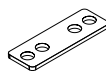

(2) 037749  
Unit-to-unit bracket



(4) 0103920  
1/4-20 x 1/2"  
Thumbscrew



(1) 025069  
Glide wrench

## 1. Table Assembly

- Place worksurface face-down onto a non-abrasive surface.
- Attach the legs to the worksurface using 1/4-20 x 5/8" PHM screws and tighten securely. **Figure 1.**
- Attach the casters and / or glides to the legs. Glides attach to the longer 28" tall legs, and casters will attach to the shorter 27" tall legs. Tighten securely with glide wrench.
- If tables are to be connected together, attach the unit-to-unit brackets as shown in **Figure 1A.**
- Carefully flip the table upright-this may require two people.

Unit-to-unit  
bracket  
(optional)

Figure 1A

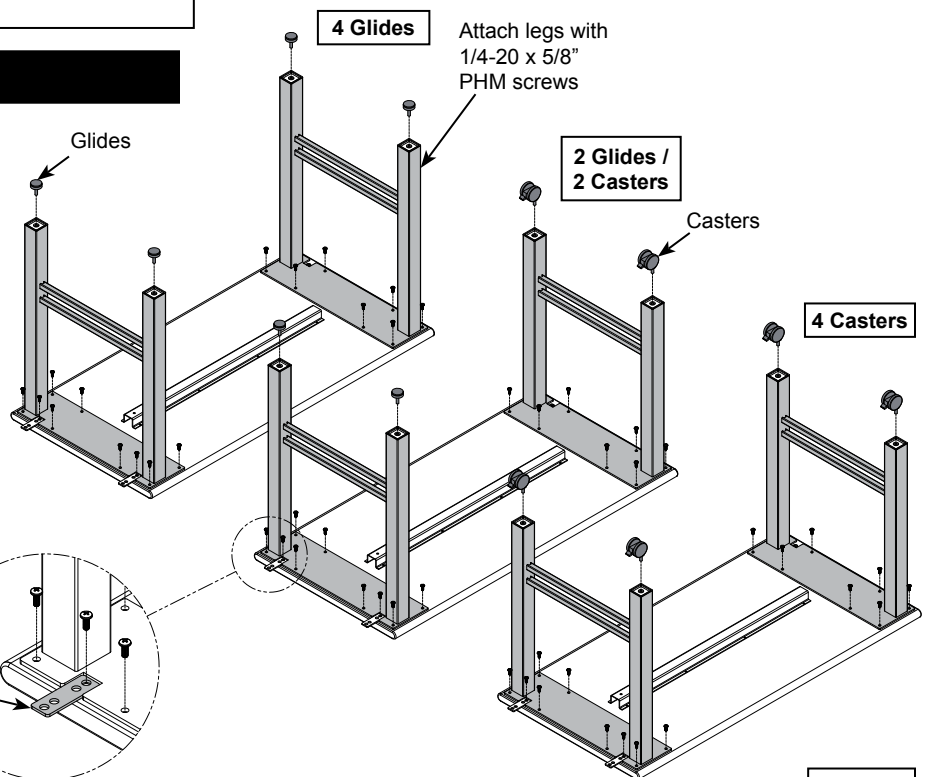
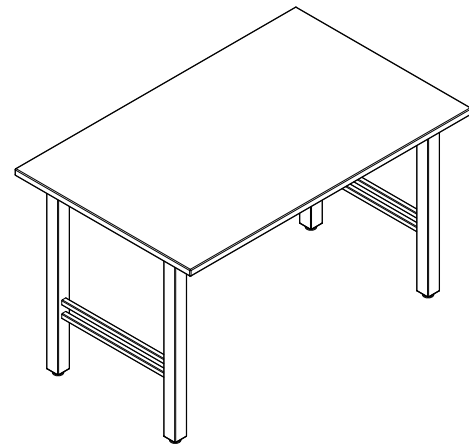

Figure 1



Flex Training Tables  
(24" and 30" deep)

372XX

Tools  
Required



Phillips  
screwdriver

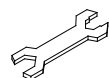

Glide  
wrench

## 2. Connecting tables together (optional)

1. Arrange the tables side-to-side in the preferred location.
2. Attach the unit-to-unit brackets to both table worksurfaces as shown with 1/4-20 x 5/8" PHM screws and tighten securely. **Figure 2.**

Note: If a more temporary arrangement is preferred, the easily removable 1/4-20 thumbscrews can be used on the unit-to-unit brackets instead of Phillips screws.

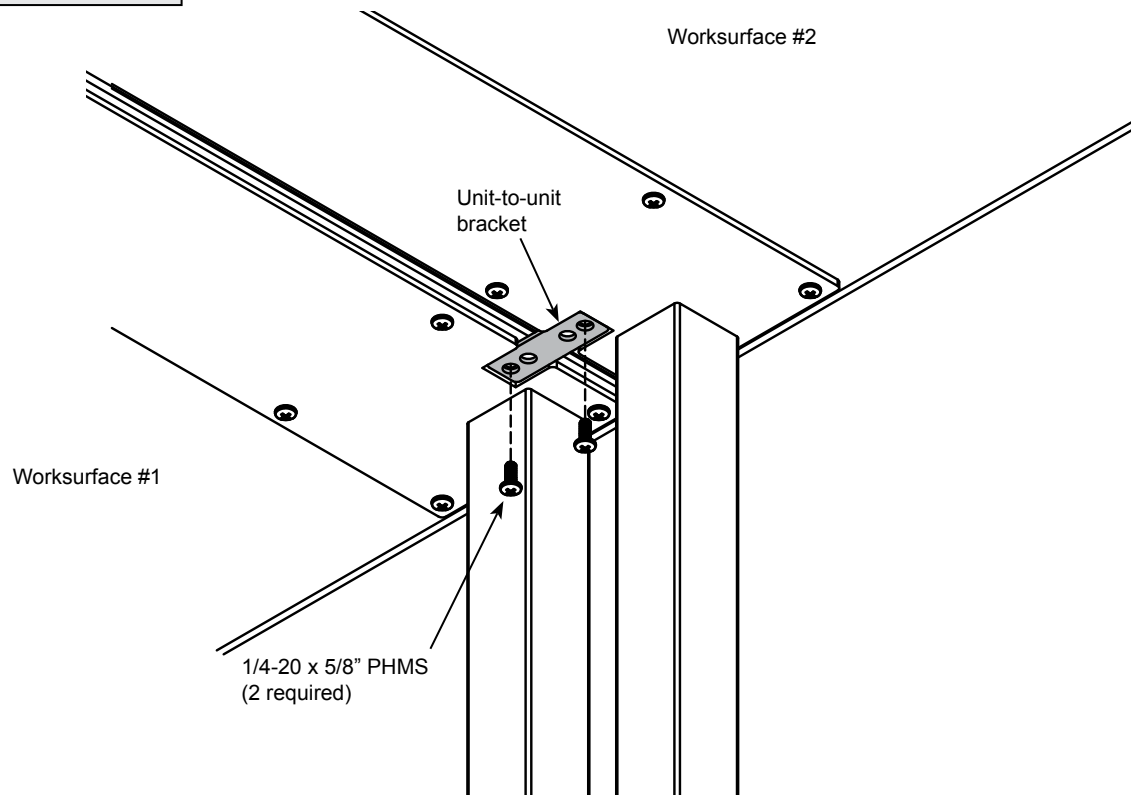

Figure 2

## 3. Moving Tables

1. If moving a table with the glide / caster combination, unlock the casters and pick up the table from the glide-side and move.
2. Lock all casters after moving.