

Technical Specifications

36"H [91.4 cm]	42"H [106.7 cm]	
55117	55116	with surround
55283	55284	with Overbridge Control Console™ (also requires 96504 insert panel)

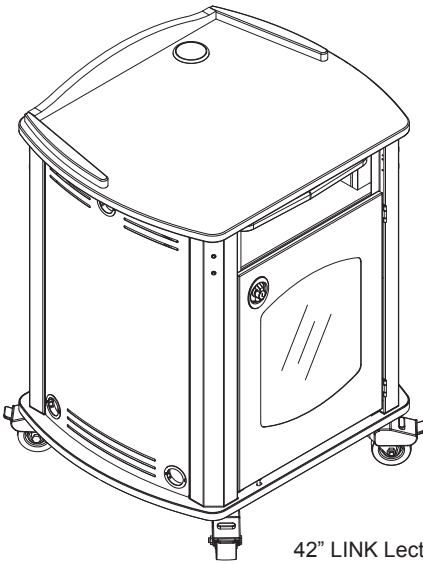

42" LINK Lectern
55116

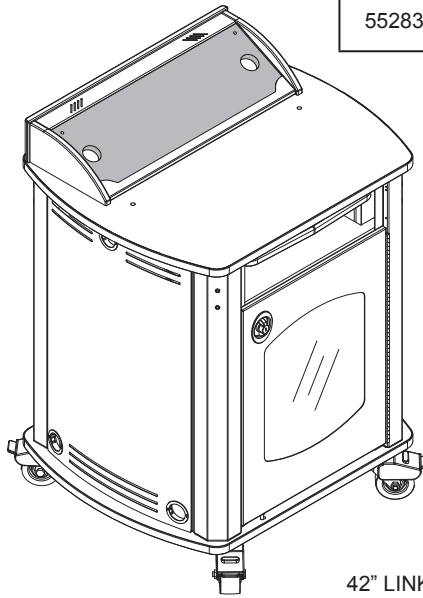

42" LINK Lectern
with Overbridge Control Console
55284
shown with insert panel (shaded)

For a compact classroom podium with so many integration possibilities, the LINK Lectern adds a unique charm to the classroom. The LINK's shape and style are very exclusive, retaining a contemporary lectern character with a modern touch. Looks aren't everything though – the LINK Lectern's performance is outstanding. It can be integrated for high-powered presentations, but is still small enough for the lecturer to easily step away and personally interact with students. And when you link technology with personal communication, a real connection with your audience is made.

Features and Benefits

- Durable powder coated steel chassis provides a long-lasting finish
- Overbridge console version allows custom cutouts and installation of presentation controllers and control panels
- Scratch and impact-resistant high-pressure laminate top provides a durable, useful worksurface for instructors
- Cable grommets on worksurface or overbridge provide cable access
- Rack-rail simplifies equipment installation, while providing enough storage space for an internal CPU tower
- HD version: Four inboard 4" heavy-duty locking plate casters with metal construction and non-marring rubber provide easy rolling, and quiet transport (rated for 300 lb each)
- TW version: Four inboard 5" locking twin-wheel plate casters provide easy-rolling (rated for 180 lb each)
- Toe kick (TK) version available when mobility is not necessary or desired
- Double bolt, keyed locks and heavy-gauge steel doors provide security and easy-access
- Blank overbridge console version allows custom cutouts and installation of presentation controllers
- Removable acrylic viewing/access panel on the front door provides easy monitoring of internal equipment
- Worksurface surround provides privacy and styling (surround version only)
- Pre-drilled left and right monitor arm mounting holes allow easy installation of a monitor arm (overbridge version only)
- Ventilated side panels help keep equipment cool
- Cable grommets throughout unit keep wires and cords organized
- Pull-out keyboard tray
- Worksurface and base panel vinyl edging protects walls and furniture
- Optional steel handle provides easy mobility
- Optional flip-up shelf provides a convenient additional worksurface
- Optional rear rack rail kit provides additional rack spaces
- Wide variety of additional options and accessories allow unit to be configured to most situations
- SCS Indoor Advantage Certified; meets or exceeds applicable ANSI-BIFMA test standards
- Warranted to be free of all defects in materials and workmanship for 10 years, electrical system 2 years

Size Options
36"H or 42"H

Base Options
TW - 5" Twin-wheel casters
HD - 4" Heavy Duty casters
TK - Toe Kick

Color Options

See spectrumfurniture.com for complete color options and combinations.

Construction

- The worksurface and base panel is constructed from 1" thick NAUF (no added urea formaldehyde) composite board with .030" high-pressure laminate on one face, and a balancing phenolic backer on the opposing face
- Metal components consist of 16-gauge and 20-gauge steel
- 16-gauge steel doors
- Solid wood worksurface surround
- Worksurface edges are covered with 3mm vinyl
- All metal components are finished with a scratch-resistant powder coat epoxy
- Each LINK Lectern is factory-assembled with casters or toe kick, packaged, and shipped on its own skid

Specifications

Internal area (nominal)	26.5"W [67.3 cm] x 23.5"D [59.7 cm] x	26.5"H [67.3 cm] (36"H version) 32.5"H [82.6 cm] (42"H version)
Standard rack rail	36"H 12RU	42"H 15RU
5" Twin-Wheel casters	Weight capacity 180 lb [81.7 kg] each	
4" Heavy-Duty casters	Weight capacity 300 lb [136.2 kg] each	
Optional flip-up shelf	22.75"W [57.8 cm] x 26.25"D [66.7 cm], 50 lb [22.7 kg] max capacity, adjusts 3" [7.62 cm] vertically in 1" [2.54 cm] increments	
Shipping weights (nominal)	36"H LINK Lectern: 192 lb [87 kg] - 55117 (HD) 221 lb [100 kg] - 55117 (TK) 221 lb [100 kg] - 55117 (TW) LINK Lectern with OCC: 208 lb [94 kg] - 55283 (HD) 221 lb [100 kg] - 55283 (TK) 221 lb [100 kg] - 55283 (TW)	42"H LINK Lectern: 218 lb [99 kg] - 55116 (HD) 236 lb [107 kg] - 55116 (TK) 211 lb [96 kg] - 55116 (TW) LINK Lectern with OCC: 206 lb [94 kg] - 55284 (HD) 236 lb [107 kg] - 55284 (TK) 216 lb [98 kg] - 55284 (TW)

Specifications subject to change without notice

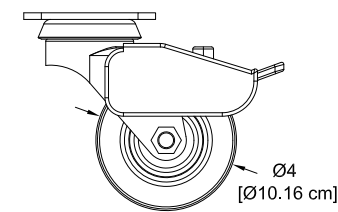

4" Heavy-Duty (HD) caster

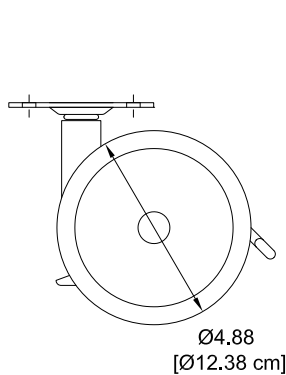
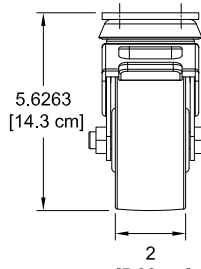

5" Twin-Wheel (TW) caster

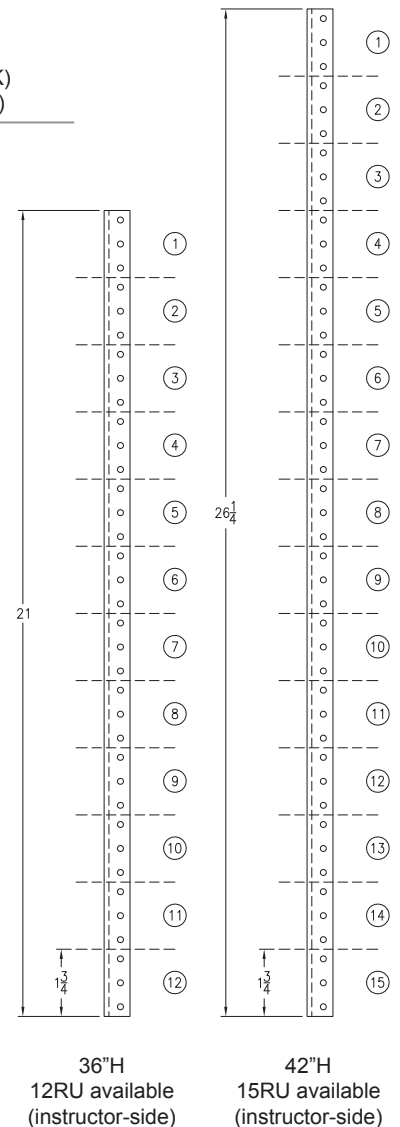
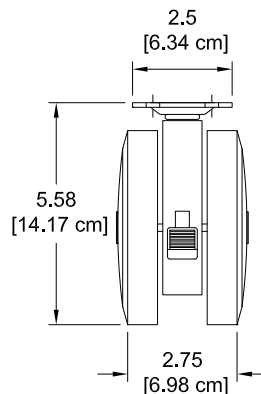

Models

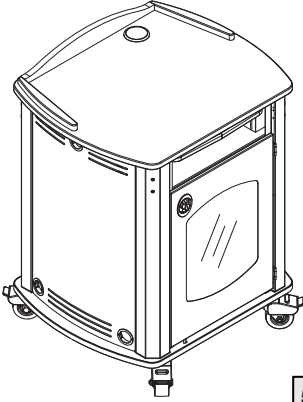
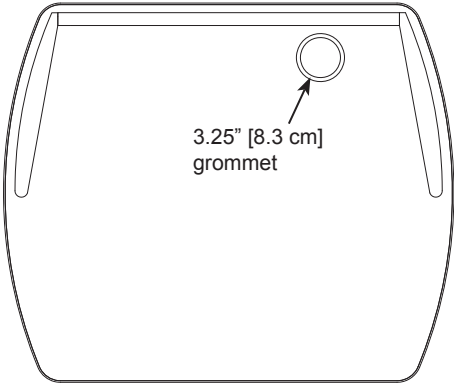
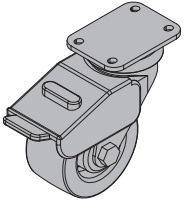
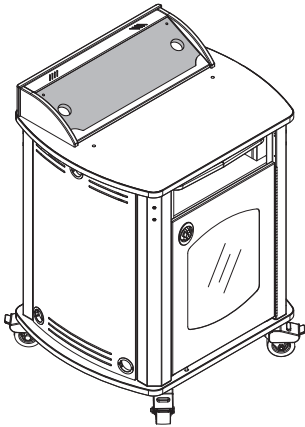
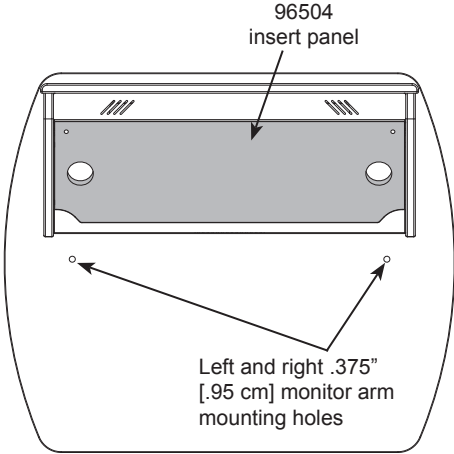
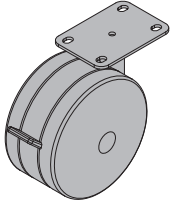
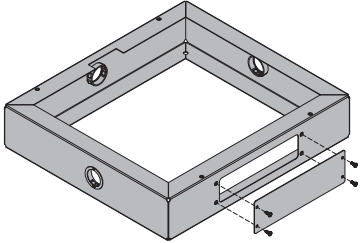
	Worksurface:	Base Options:
<p>Standard LINK Lectern</p>  <p>55116 - 42"H 55117 - 36"H</p>	 <p>3.25" [8.3 cm] grommet</p> <p>Surround with one 3.25" [8.3 cm] grommet in worksurface.</p>	 <p>X 4</p> <p>HD 4" Heavy-Duty locking casters</p>
<p>LINK Lectern with Overbridge Control Console™</p>  <p>Note: The insert panel shown (<i>shaded</i>) is <u>not</u> included with the lectern or overbridge. This option needs to be ordered separately to complete the overbridge.</p> <p>55284 - 42"H 55283 - 36"H</p>	 <p>96504 insert panel</p> <p>Left and right .375" [.95 cm] monitor arm mounting holes</p> <p>Overbridge with blank insert panel for custom cutouts (see p.8 for dimensions). Overbridge is not available separately. Includes two 2" [5 cm] grommet holes with covers.</p> <p>Worksurface in front of overbridge includes two .375" [.95 cm] holes with plugs for optional monitor arm mounting.</p>	 <p>X 4</p> <p>TW 5" Twin-Wheel locking casters</p>  <p>TK Toe Kick</p>

42" LINK Lectern
with HD casters
(shown with optional steel
handle and flip-up shelf)

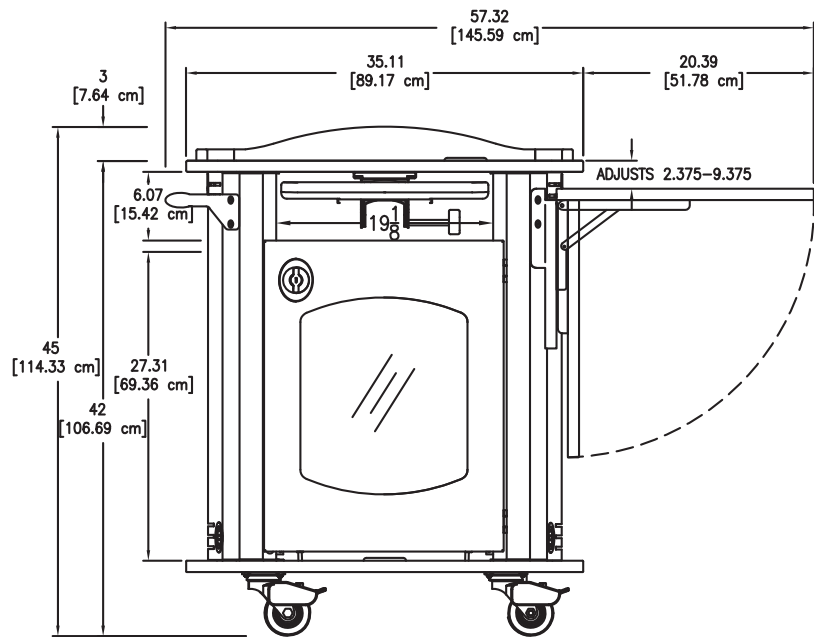
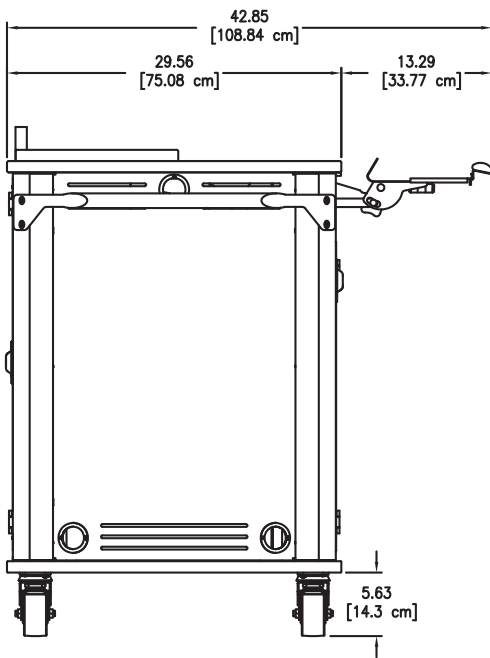
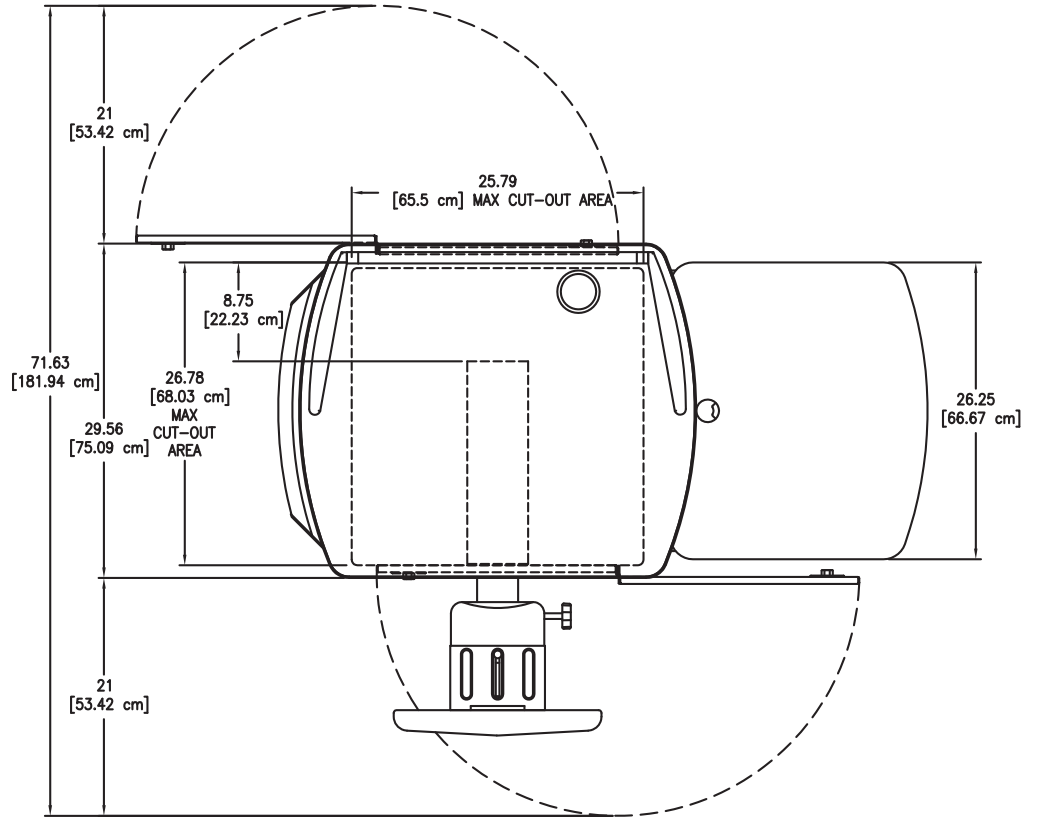
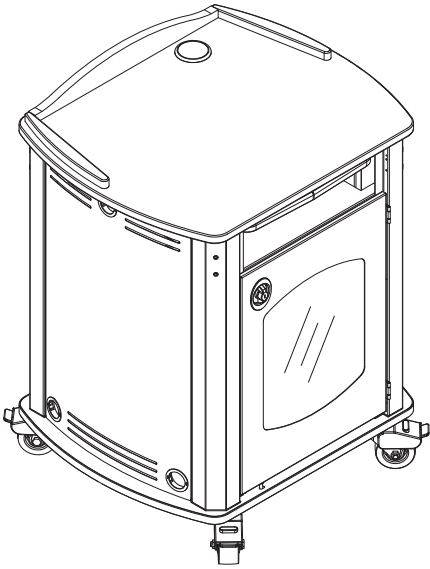

36" LINK Lectern
with TW casters

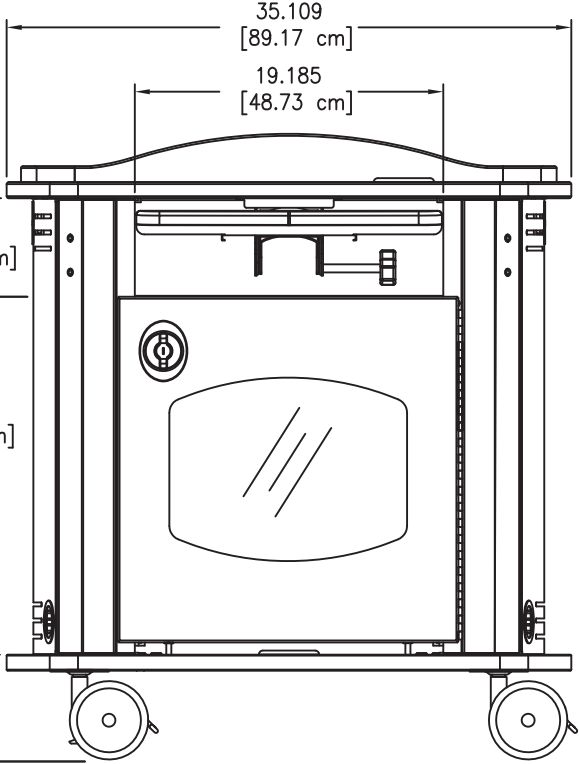
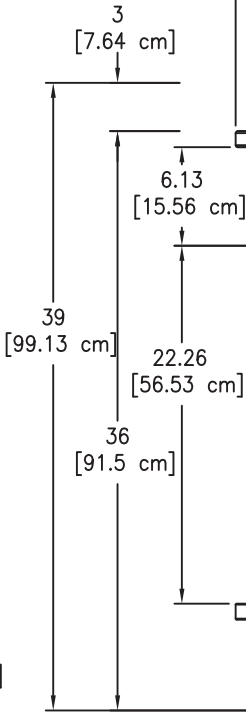
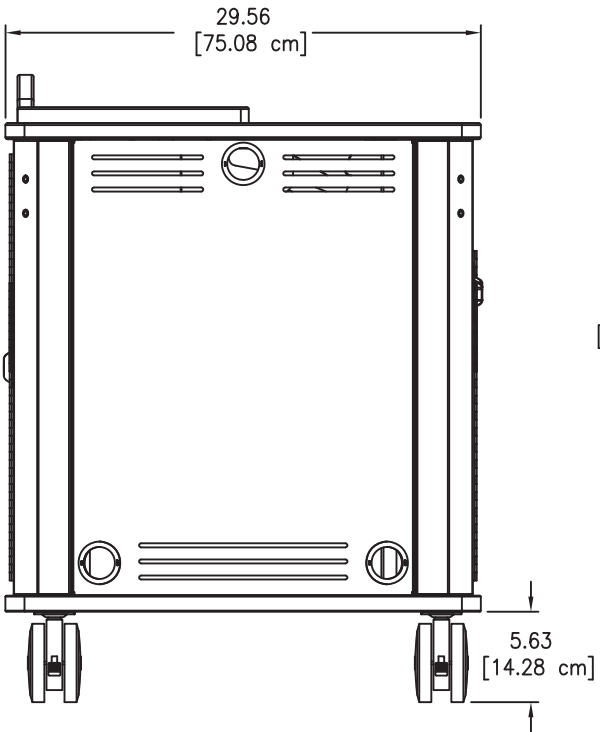

42" LINK Lectern
with Toe Kick

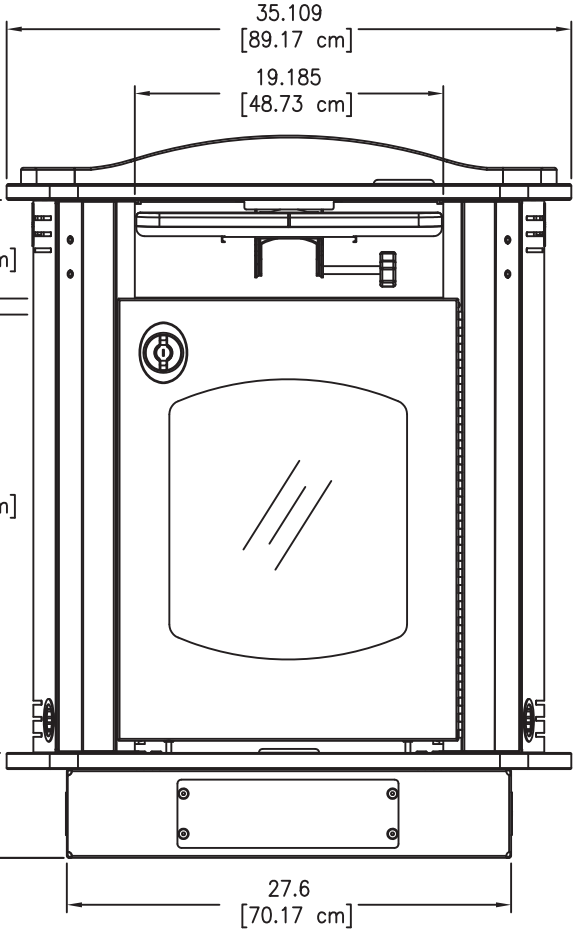
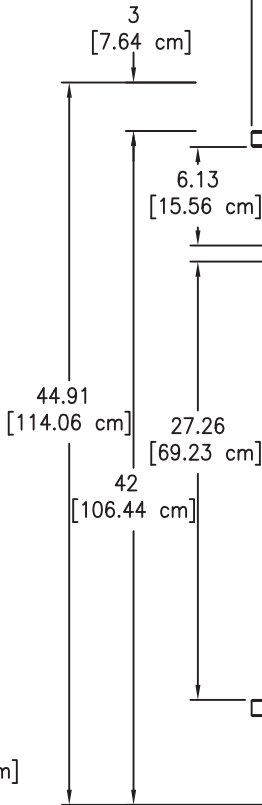
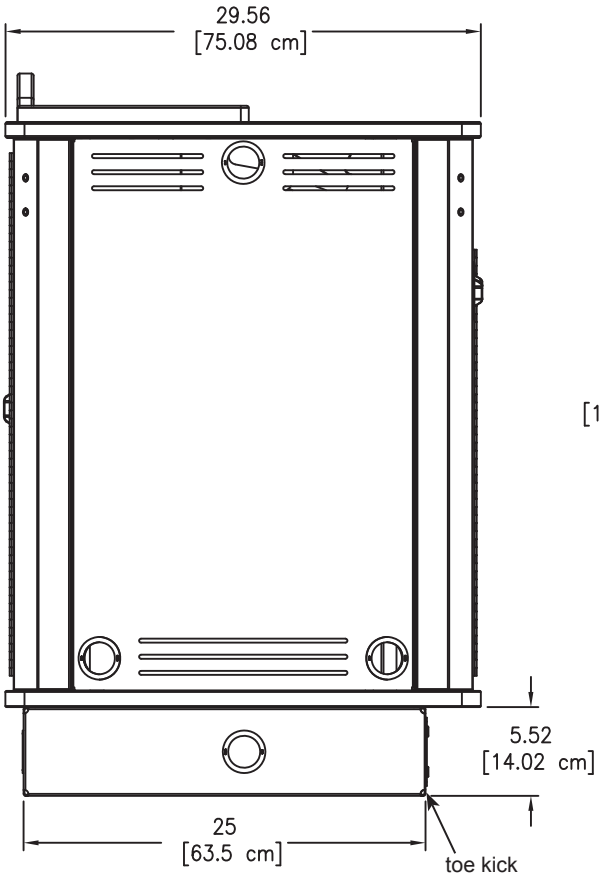

42" LINK Lectern
with HD casters
and Overbridge Control Console™

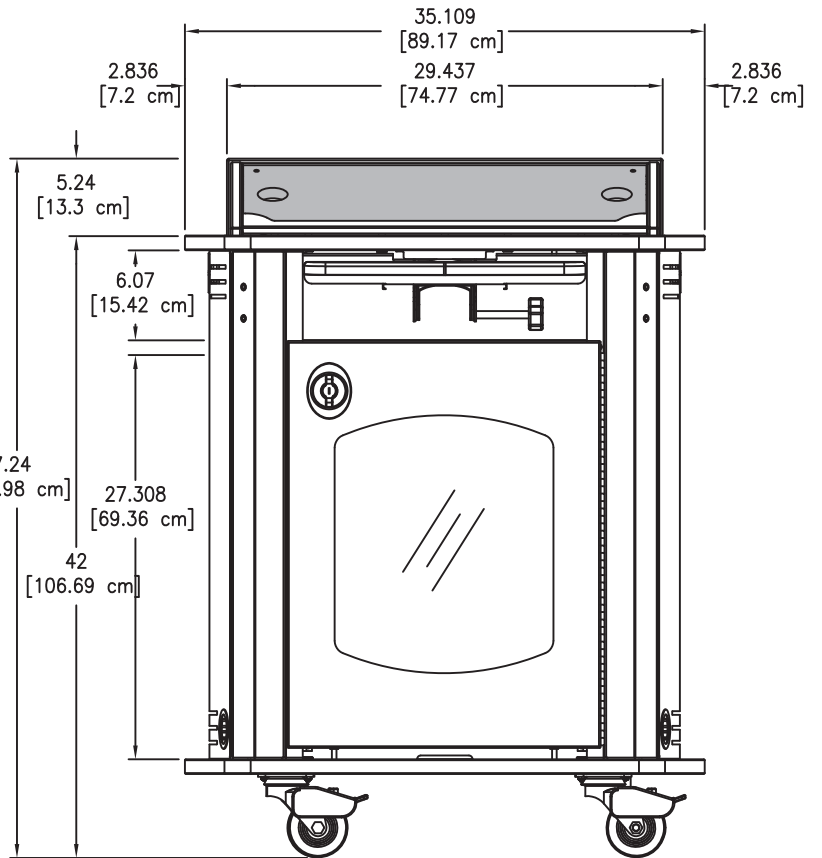
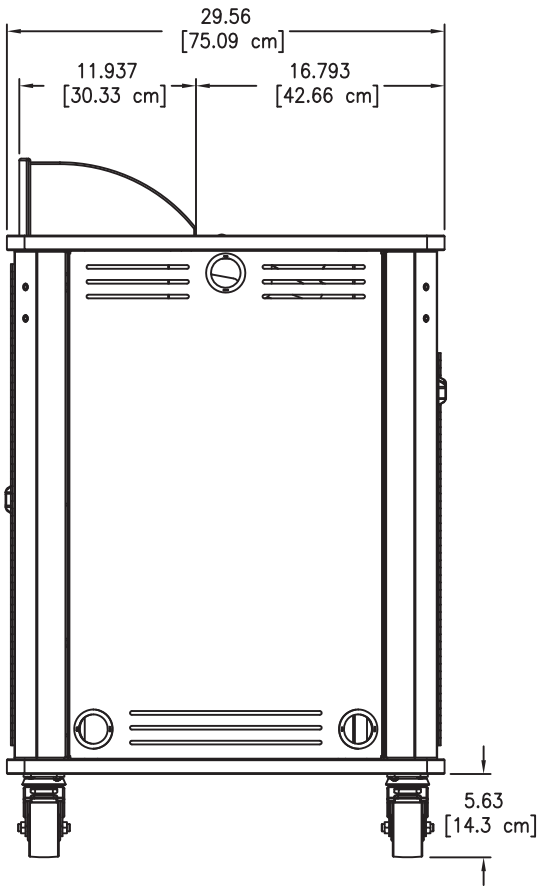
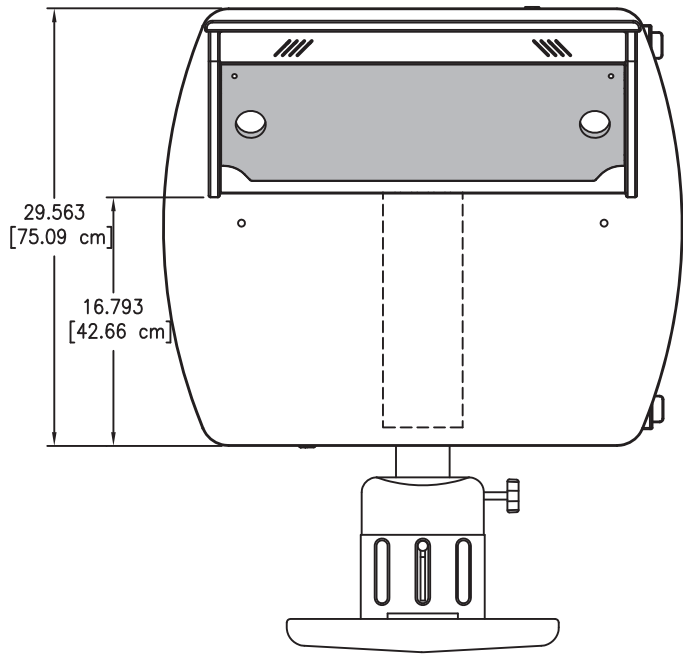
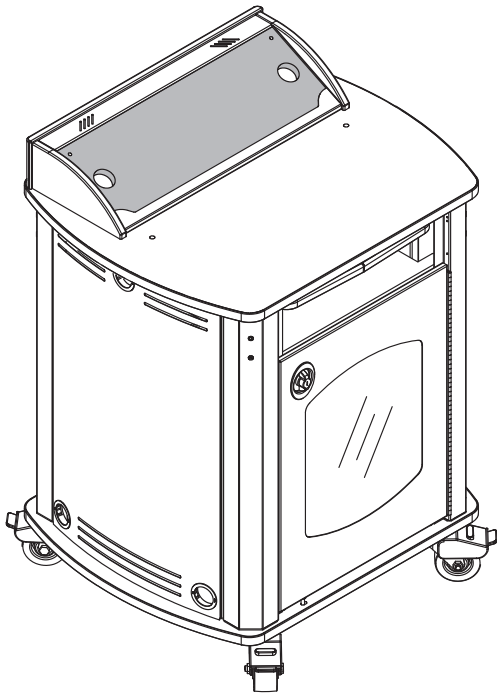

42" LINK Lectern
with Overbridge Control Console™
section view

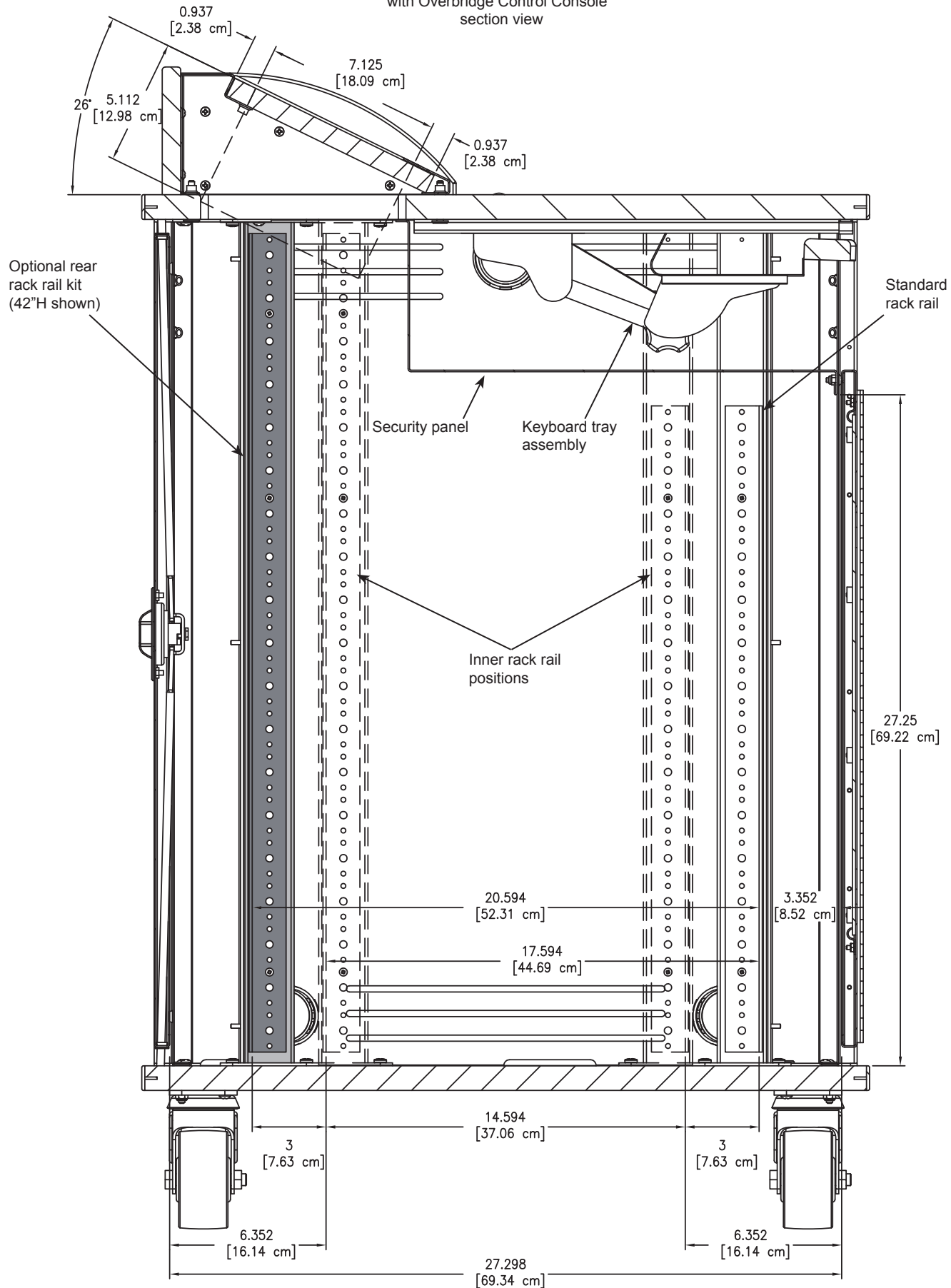

LINK Lectern overbridge panel blank
(flat view)

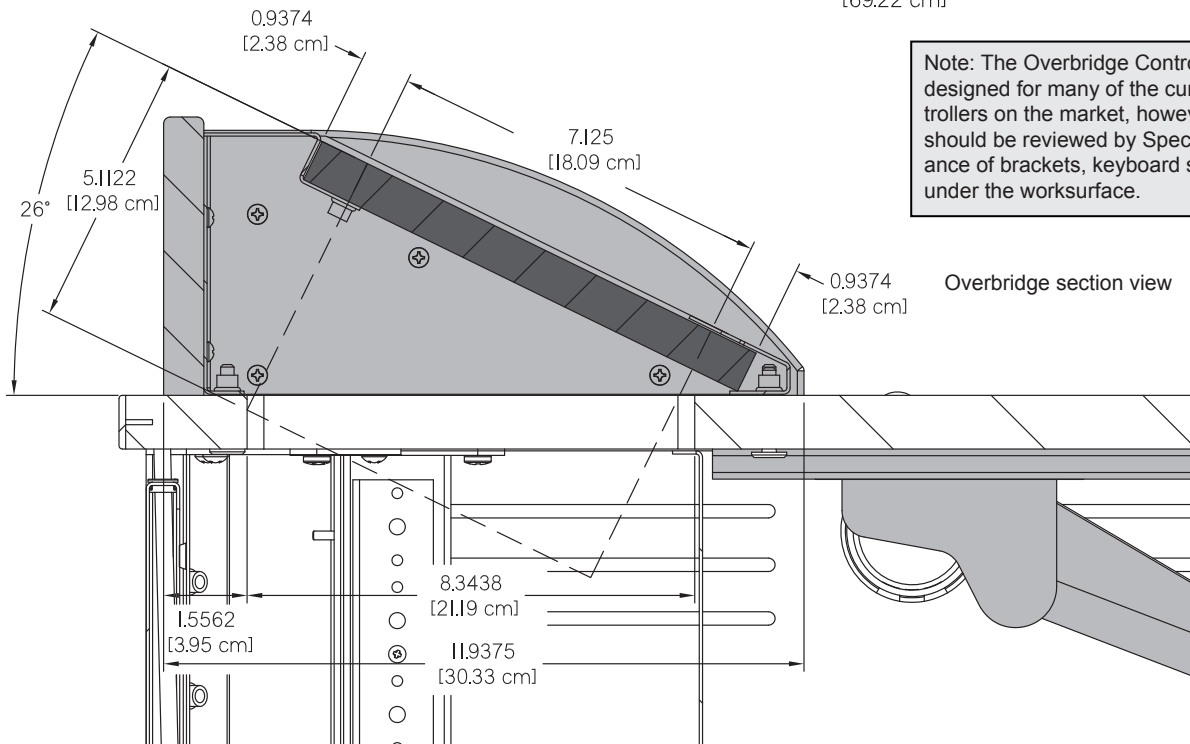
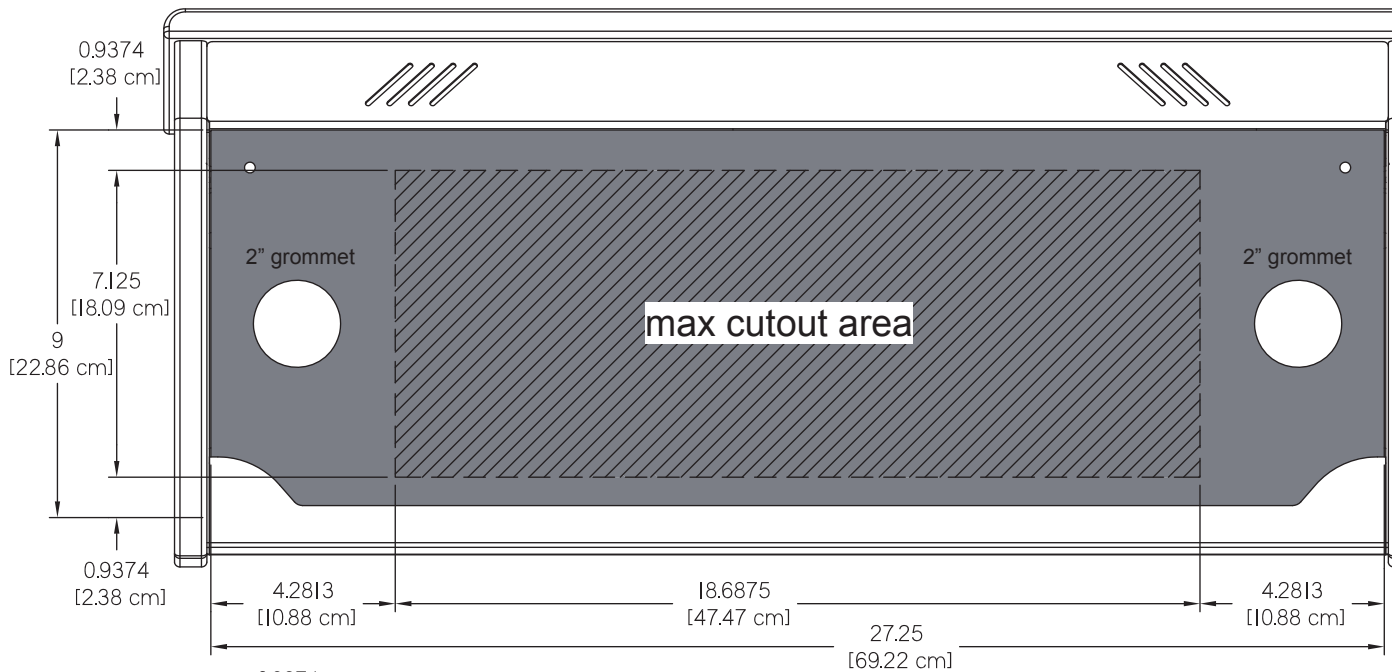

Note: The Overbridge Control Console™ has been designed for many of the currently available controllers on the market, however, modified cutouts should be reviewed by Spectrum to ensure clearance of brackets, keyboard slides, or other objects under the worksurface.

Note: The insert panel shown (*shaded*) is **not** included with the lectern or overbridge. This option needs to be ordered separately to complete the overbridge. This insert panel is horizontally symmetrical and can be easily removed, rotated, and re-installed if a cutout needs to be relocated to the opposite side of the overbridge.

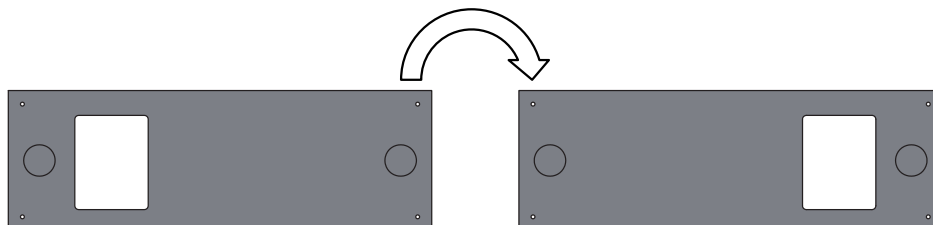

Available positions on LINK base panel
for optional cord reel

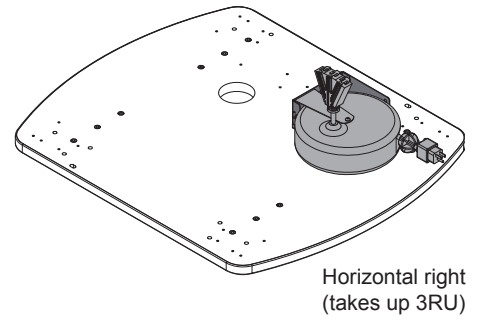
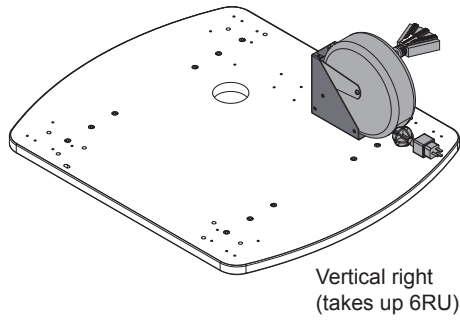
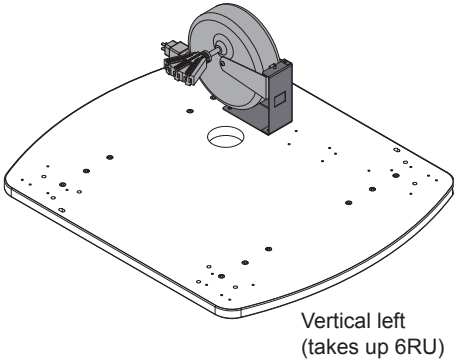

LINK with optional universal cord reel kit 99037
(available rack spacing)

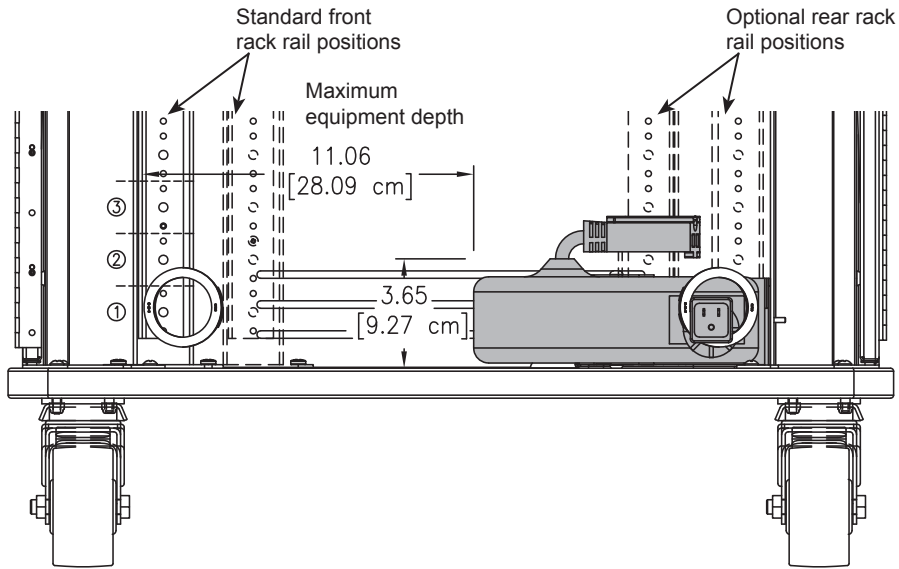

Note: The cord reel must be mounted in the flat, horizontal position when used along with the optional rear rack rail kit (55134 or 55139).

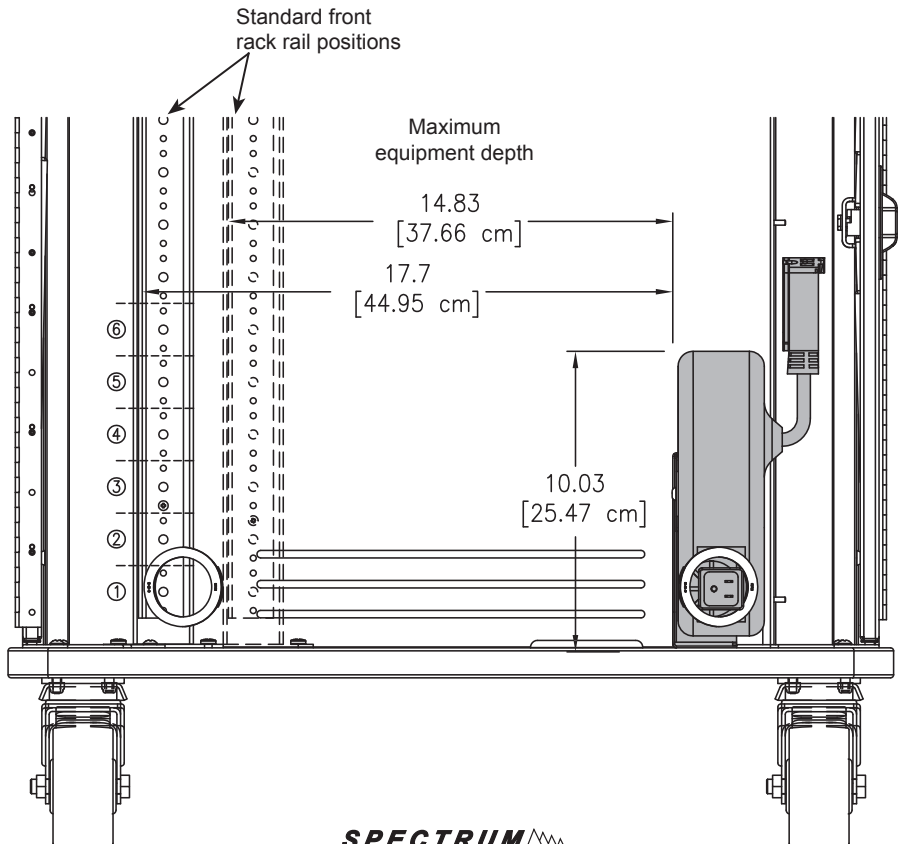

Accessories

Note: Flip-up document shelf and steel handle are interchangeable and can be mounted on either side.

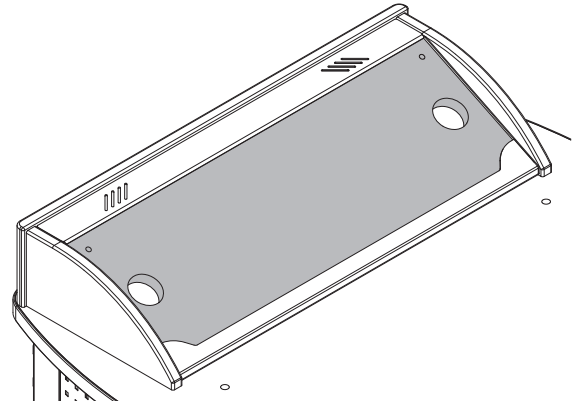
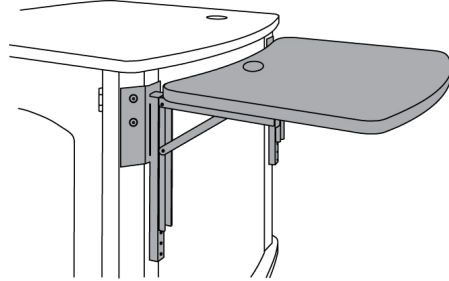
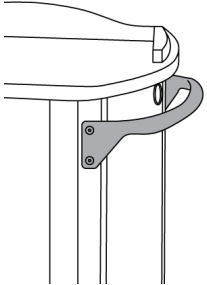

Steel Handle - 55132

- 27.5"W [69.9 cm]

Flip-up Shelf - 55140

- 22.75"W [57.8 cm] x 26.25"D [66.7 cm]
- Mounts on left or right side
- Includes 2" grommet
- Six height positions
- 35 lb [15.9 kg] max capacity

Overbridge Insert Panel Blank - 96504

Overbridge Insert Panel with cutouts - 96504mod

- For overbridge version only
- Contact Spectrum to specify cutout size(s) and location(s)
- Overbridge not available separately
- Includes two 2" grommets with covers
- Customer-installed

Note: Power and communication wiring for document cameras, laptop computers, and/or projectors placed on the flip-up shelf should be routed on top of the audience-side of the shelf. Use of the shelf grommet hole for wiring will result in pinching of the cords when the shelf is folded.

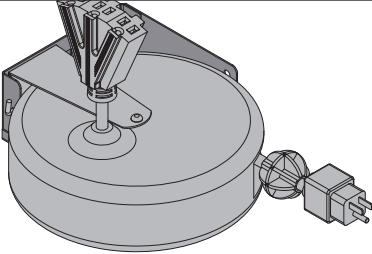



Universal Cord Reel Kit - 99037

- Includes universal mounting bracket
- Mounts horizontally or vertically inside unit to base panel
- 15' [457.2 cm] retractable cord
- 12 AWG with breaker
- 10.8 lb [4.9 kg]

Note: When installed, the cord reel takes up rack units from the bottom of the rack rail.

Horizontal installation: 3RU
Vertical installation: 6RU

The cord reel is intended to provide temporary access to electrical outlets. Check local electrical codes prior to installation.

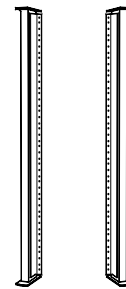

LINK Lectern Rear Rack Rail Kit

- 42"H - 19RU (15RU full-depth) - **55139**
- 36"H - 15RU (12RU full-depth) - **55134**



Flat Panel Monitor Arm

95512 - "Light-Duty" for monitors weighing 2-13 lb [.9-5.9 kg]

95522 - "Medium-Duty" for monitors weighing 7.5-25 lb [2.5-11.4 kg]

95509 - "Heavy-Duty" for monitors weighing 12-31 lb [5.4-14 kg]

- Six mounting options (clamp, thru-desk, wall, grommet hole, side bolt, reverse wall)
- Compatible with all VESA® monitors – includes 75mm and 100mm VESA® adapters
- Cable management concealed in arm

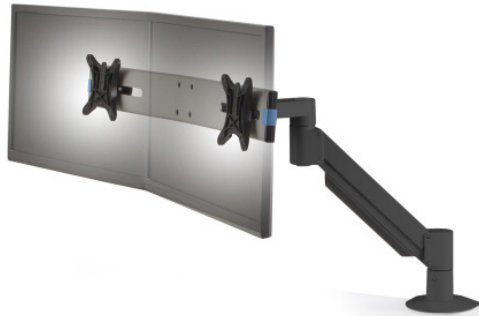

Dual Flat Panel Monitor Arm - 95533

- Weight range: 3.5-13 lb [1.6-5.9 kg] per monitor
- Six mounting options (clamp, thru-desk, wall, grommet hole, side bolt, reverse wall)
- Compatible with all VESA® monitors – includes 75mm and 100mm VESA® adapters
- Cable management concealed in arm

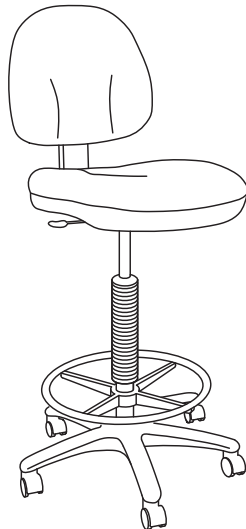

Adjustable Drafting Stool - 38202

- 40-52" height-adjustment via pneumatic cylinder
- 360° swivel
- Tilting backrest
- 18" diameter fixed foot ring
- 5-star base

Rack-mount Accessories

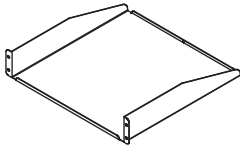

Cantilever Shelf - 2RU - 97504

- 16ga steel
- Shelf: 17.5"W [44.45 cm] x 18"D [45.7 cm] x 3.5"H [8.89 cm]
- Weight capacity: 50 lb [22.7 kg]
- Shipping weight: 8.1 lb [3.7 kg]

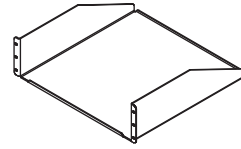

Cantilever Shelf - 3RU - 97502

- 16ga steel
- Shelf: 17.5"W [44.45 cm] x 18"D [45.7 cm] x 5.25"H [13.33 cm]
- Weight capacity: 80 lb [36.3 kg]
- Shipping weight: 9.2 lb [4.2 kg]

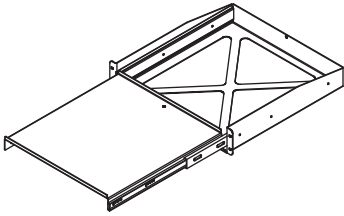

Pull-Out Shelf - 2RU - 97505

- 16ga steel
- 17.09"W [43.42 cm] x 18.12"D [46.03 cm] x 3.5"H [8.89 cm]
- Weight capacity: 50 lb [22.7 kg]
- Shipping weight: 15.6 lb [7.1 kg]

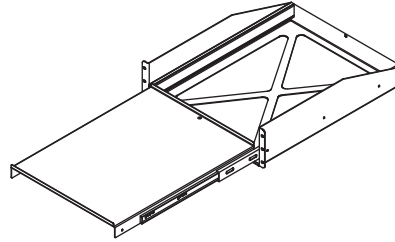

Pull-Out Shelf - 3RU - 97503

- 16ga steel
- 17.09"W [43.42 cm] x 22.11"D [56.14 cm] x 5.25"H [13.33 cm]
- Weight capacity: 80 lb [36.3 kg]
- Shipping weight: 18.5 lb [8.4 kg]

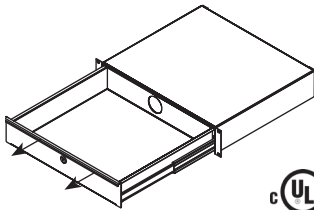

Locking Drawer - 2RU - 97523

- 16ga steel
- Drawer: 15.97"W [40.56 cm] x 14.56"D [36.98 cm] x 3"H [7.63 cm]
- Weight capacity: 50 lb [22.7 kg]
- Shipping weight: 15.85 lb [7.2 kg]

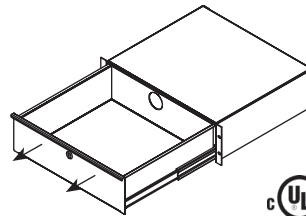

Locking Drawer - 3RU - 97522

- 16ga steel
- Drawer: 15.97"W [40.56 cm] x 14.56"D [36.98 cm] x 5.25"H [13.33 cm]
- Weight capacity: 50 lb [22.7 kg]
- Shipping weight: 18.5 lb [8.4 kg]

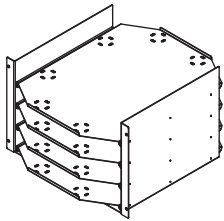

LT-4 Laptop Storage Unit - 7RU - 97517

- Holds four full-size laptops
- 16ga & 20ga steel
- 18.75"W [47.94 cm] x 20.5"D [52.11 cm] x 12.25"H [31.11 cm]
- Shipping weight: 30 lb [13.6 kg]

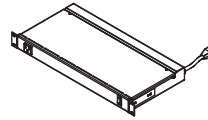

9-Outlet Power Strip - 1RU - 99021

- 8 outlets rear (breaker-protected)
- 1 convenience outlet front
- 115VAC, 60 Hz, 15 amps max
- 9' power cord
- Front LED power switch
- Enhanced surge protection
- ETL-listed, UL-listed
- 19"W [48.27 cm] x 9.25"D [23.5 cm] x 1.74"H [4.41 cm]
- Shipping weight: 8.7 lb [3.9 kg]

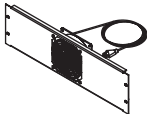

Single Fan - 3RU - 97507

- 50 cfm
- 120V~50/60 Hz, 15/13W
- RoHS
- 19"W [48.27 cm] x 1.56"D [3.97 cm] x 5.25"H [13.33 cm]
- Shipping weight: 3.78 lb [1.7 kg]

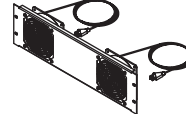

Double Fan - 3RU - 97506

- 100 cfm
- 120V~50/60 Hz, 15/13W
- RoHS
- 19"W [48.27 cm] x 1.56"D [3.97 cm] x 5.25"H [13.33 cm]
- Shipping weight: 5.47 lb [2.5 kg]

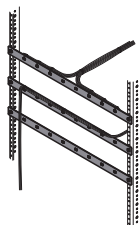

Wire Lace Kit - 95517

- Provides wire management
- Mounts to standard rack rails
- Includes (3) lace straps and mounting screws
- Includes (12) 5.5" zip ties
- Shipping weight: 1.25 lb [.57 kg]

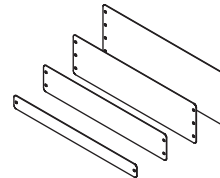

Rack-Mount Blanks

1RU - 97510 **3RU - 97512**
2RU - 97511 **4RU - 97513**

- Fills rack spaces where components are not needed
- 16 ga steel
- Shipping weight: <1 lb [.45 kg]

See spectrumfurniture.com for the latest accessories and detailed warranty information.

Warranty

We will make it right for you!

Spectrum is committed to provide complete customer satisfaction. Each of our products is manufactured from the best materials available and each product is stringently monitored throughout the production process through our P.A.C.E. program (Product Assurance to meet Customer Expectations).

We expressly warrant that Spectrum products will be of good quality and workmanship and free from defect for the period set out in the warranty table below from the date of delivery. This warranty shall not apply to defects or damage resulting from misuse, abuse, neglect, improper care, modification or repair not authorized by Spectrum, or any other cause outside the control of Spectrum. Spectrum will, at its sole option, either repair or replace the defective product.

This warranty is exclusive; no other warranty, written or oral, is expressed or implied. This warranty is given by Spectrum to Buyer and to no other person or legal entity. No Spectrum dealer, distributor, agent or employee is authorized to make any modification or addition to this warranty.

NOTWITHSTANDING ANYTHING TO THE CONTRARY, SPECTRUM WILL NOT UNDER ANY CIRCUMSTANCES BE LIABLE FOR INDIRECT OR LIQUIDATED DAMAGES, INCLUDING CONSEQUENTIAL, INCIDENTAL AND SPECIAL DAMAGES. IN NO EVENT SHALL SPECTRUM'S LIABILITY, WHETHER UNDER CONTRACT OR WARRANTY, IN TORT OR OTHERWISE, EXCEED THE PURCHASE PRICE RECEIVED BY SPECTRUM FOR THE PRODUCT AT ISSUE AND "RECALL ACTION" EXPENSES. SPECTRUM SHALL NOT BE SUBJECT TO ANY OTHER OBLIGATIONS OR LIABILITIES, WHETHER ARISING OUT OF BREACH OF CONTRACT, WARRANTY, TORT (INCLUDING NEGLIGENCE AND STRICT LIABILITY) OR OTHER THEORIES OF LAW, WITH RESPECT TO PRODUCTS SOLD OR SERVICES RENDERED BY SPECTRUM, OR ANY UNDERTAKINGS, ACTS OR OMISSIONS RELATING THERETO.

Our Customer Service Department is ready to provide immediate attention to any questions, comments or concerns. They are available to answer your calls Monday through Friday from 7 am to 5 pm CST. In addition your product comments or concerns are welcome via e-mail at: spectrum@spectrumfurniture.com.

Warranty Table

Item	Warranty Period
Adjustable Crank / Electric Desk Legs	• 1 Year
Flat Panel Desk Gas Cylinders	
Chairs <ul style="list-style-type: none"> • Adjustable Height Chair Parts – including frames, gas cylinders, wood and plastic parts, control handles, casters • Adjustable Height Chair Upholstery • In-Stock Upholstery • Graded-In Fabrics and Customer Owned Material 	<ul style="list-style-type: none"> • 7 Years • 2 Years • 2 Years • No Warranty
Height Adjustable Columns and Lifts	• 1 Year
General Use Casters	
Electrical (including timers and LINAK actuators)	• 2 Years
Keyboard / Mouse Trays	• 1 Year
Flat Panel Monitor Arms <ul style="list-style-type: none"> • Flat Panel Monitor Arm – General Parts • Flat Panel Monitor Arm – Gas Cylinders 	• 10 Years
Desks and Lecterns <ul style="list-style-type: none"> • Computer Desk Chassis • Cart Chassis • Lectern Chassis 	• 10 Years

