

LT-24 Laptop Cart (H3)

55174 LT-24 w/ 5" balloon wheels

Choose (one) of the following designations and add to part #:

SR - 2 rigid, 2 swivel balloon wheels
(provides more control when mobile)
BW - 4 swivel balloon wheels

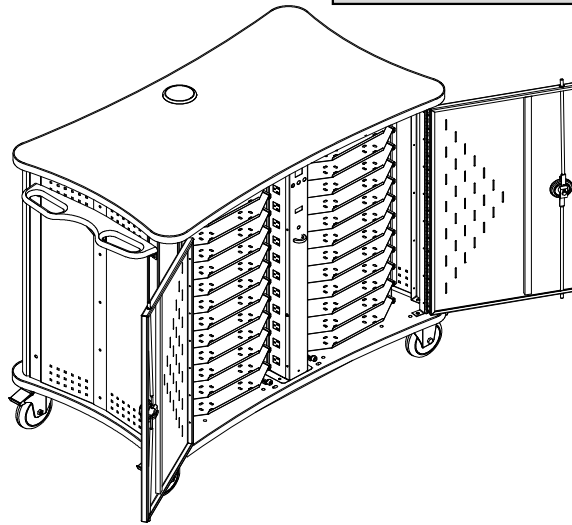
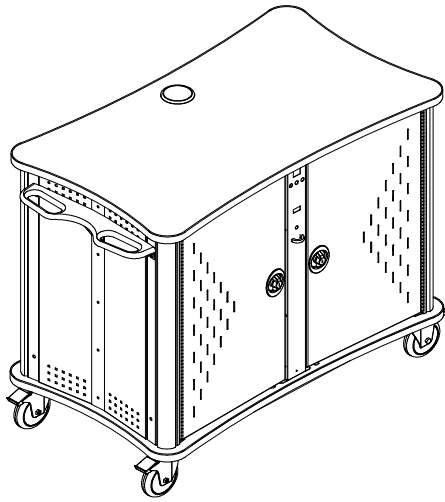

Holding up to 24 laptops, the LT24 can support an entire classroom of laptops while providing secure storage and controlled recharging all in one. The design of the cart allows quick loading and unloading of laptops for the students due to two full columns of trays. The laptops lay flat on pull-out trays that allow the students to grasp the laptop with both hands, lessening the chance for damage. Never worry again whether your laptops are charged and ready. Just set them in the LT24, plug them in, and leave them until they are needed again. With the intelligent charging system you have total control. All Spectrum laptop carts that can store more than 15 laptops at a time employ a cycle charger. This insures proper charging, prevents overloaded circuits, and peace of mind for the instructor.

Features and Benefits

- Holds up to 24 laptops (12 on each side)
- 24 laptop trays pull-out from the front and back, providing quick-access to laptops and cables
- Four 5" locking balloon wheels roll easily and quietly on uneven surfaces
- One standard ergonomic handle provides control and mobility (can be mounted on either side)
- Standard 15' retractable 15-amp power cord reel provides quick and easy power-access
- Double-bolt, keyed locking front and rear doors provide security and easy-access
- Cycle charger with timer and conveniently-located power outlets provide easy charging
- 15-amp breaker on each circuit protects laptops from electrical overload.
- One seven-outlet insured power strip with surge-protector and 12' cord for additional peripherals
- Scratch and impact-resistant 1¹/₁₆" high-pressure laminate worksurface
- Ventilated side and door panels help dissipate heat
- Cable grommets and wire management located in each tray keep wires and cords organized (Velcro® tie-downs included)
- 3" covered grommet on worksurface provides power strip access
- 1⁷/₈"W x 3¹/₄"D rectangular grommet in bottom worksurface provides access to cord reel
- Warranted to be free of all defects in materials and workmanship with a 10-year warranty

Construction

- The worksurface is constructed from 1¹/₁₆" thick NAUF (No Added Urea Formaldehyde) composite board with .030 high-pressure laminate on one face, and a balancing phenolic backer on the opposing face
- Metal components consist of 16-gauge and 20-gauge steel
- 20-gauge steel pull-out laptop trays and side panels
- 16-gauge steel doors and corner columns
- Solid wood corner column trim
- Worksurface edges are covered with 3mm vinyl
- Ergonomic handle is made of black recycled plastic
- All metal components are finished with a scratch-resistant powder coat epoxy
- Each LT-24 is factory-assembled (except for handle) w/ wheels, packaged,

Capacity

- Overall dimensions: (See dimensioned drawings)
- Storage and charging capacity for up to 24 laptops
- Pull-out laptop tray dimensions: 16¹/₄"W x 20⁵/₈"D x 2¹⁵/₃₂"H
- The 5" balloon wheels have a weight capacity of 325 lbs each
- 15' retractable 15-amp cord reel
- Meets or exceeds all ANSI-BIFMA test standards
- Features and specifications subject to change without notice
- **Unit weight (nominal):** 300 lbs
- **Shipping weight (nominal):** 345 lbs

Touchboards

205 Westwood Ave, Long Branch, NJ 07740
Phone: 866-94 BOARDS (26273) / (732)-222-1511
Fax: (732)-222-7088 | E-mail: sales@touchboards.com

Color Options

Standard laminate / Color combinations:



-Wild Cherry / Black (CHB)



-Indigo Organix / Dark Gray (ID)

Standard color combination refers to the quickest deliverable product color combination. Custom laminates and color combinations are available-additional lead-times and up-charges may apply. Call 800-235-1262 for further information.

**55174SR
LT-24 Laptop Cart**

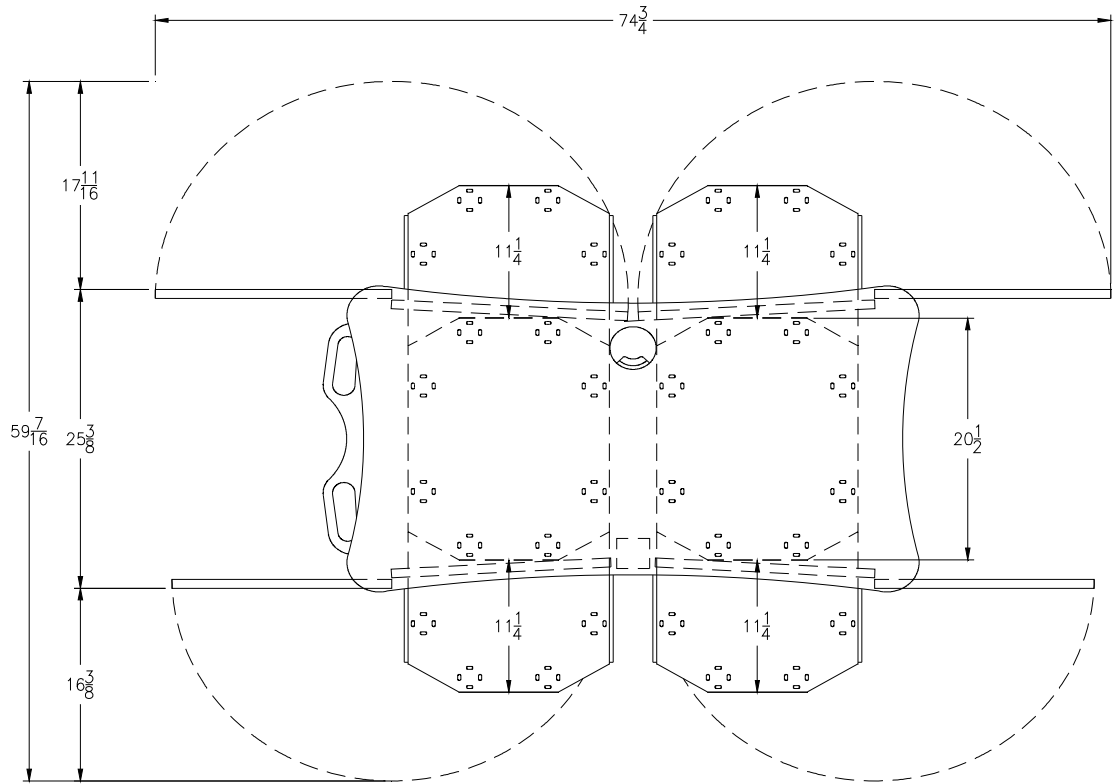

Top view

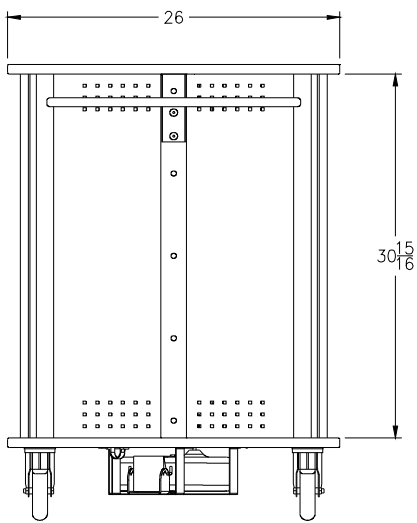

Left-side view

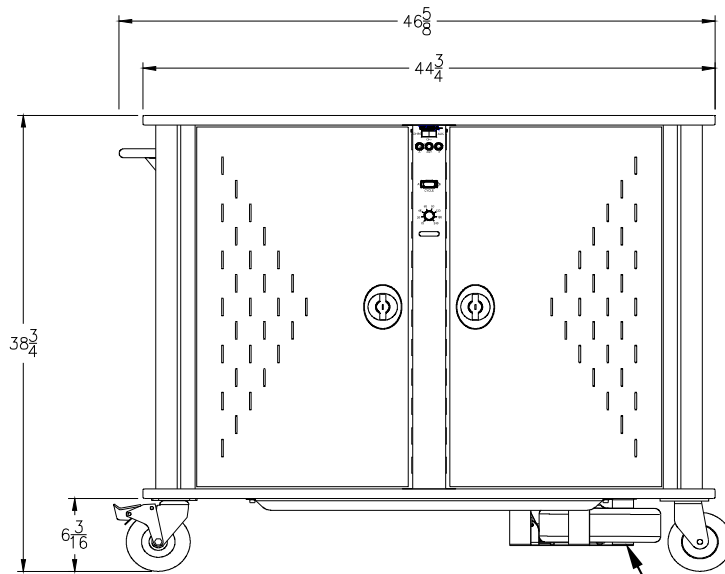

Instructor-side view

Standard 15' Cord Reel
(15-amp)

Cycle Charger

- The cycle charger intermittently charges two sets of up to 12 laptops (24 total) using a timed switch that provides accurate timed charging/switching and can be set between 15 and 240 minutes.
- 3-position, manual-override / cycle rocker switch with LED indicators switches between charging or auxiliary circuits (A,B-green, AUX-amber)
- 3-position, manual-override / cycle rocker switch switches charging between the A side, cycle charging, or B side
- 15-amp circuit breaker on each charging circuit (breakers protect the laptops from electrical overload)
- Wired with 14 AWG wire

Note: Spectrum does not recommend charging more than 12 laptops at once, or modifying the cycle charger to charge more than 12 laptops at a time. Damage to electrical wiring, charging system, or laptops could result.

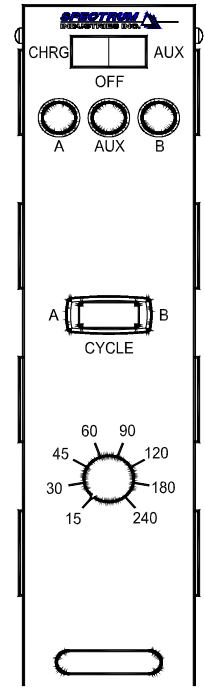

Cycle Charger

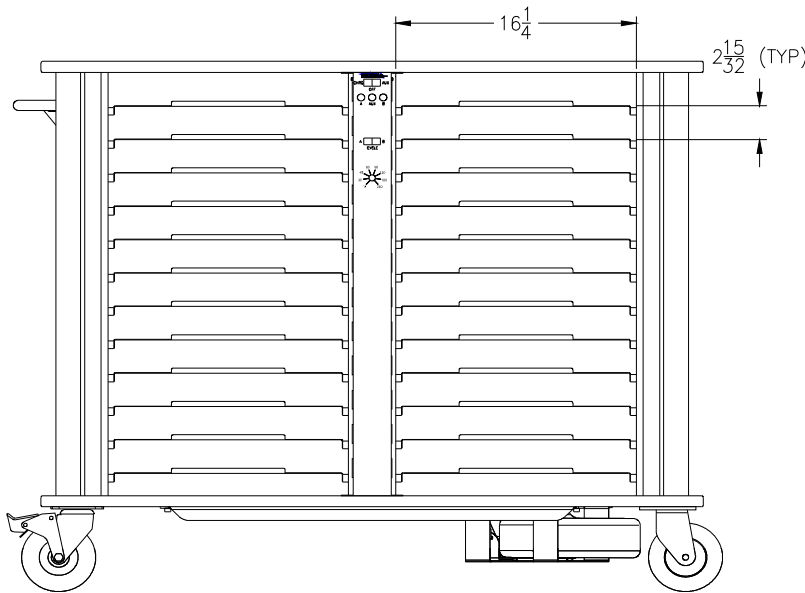

(shown without doors)

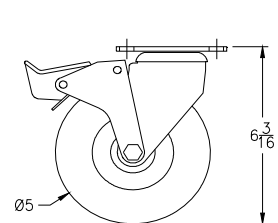
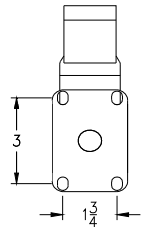
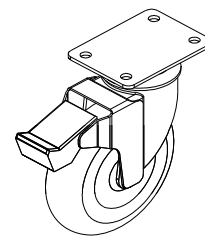

5" Balloon Wheel

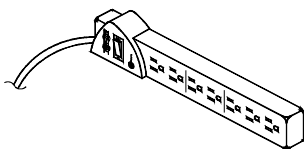
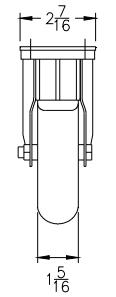

Standard 7-Outlet Power Strip, insured w/ surge protector, bracket, and 12' cord
10"W x 2"D x 1 1/8"H

Note: If you have the (SR) version (2 rigid, and 2 swivel wheels) on your particular cart, mounting the handle on the same side as the two swivel wheels will provide more control of the cart when mobile.

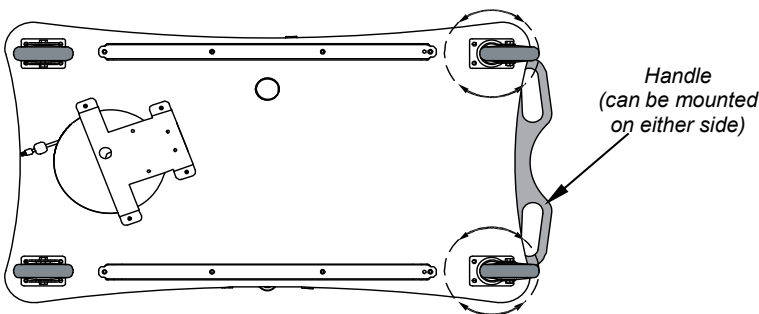

(SR) = 2 rigid, 2 swivel wheels
(provides more control when mobile, but less maneuverability in tight spaces)

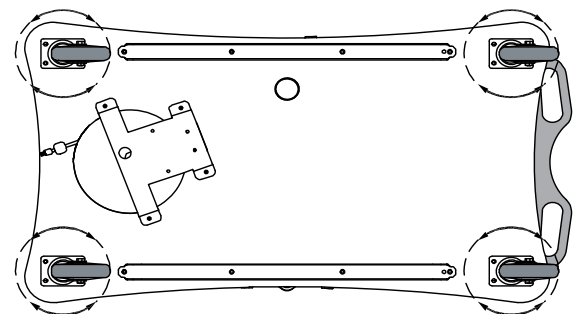

(BW) = 4 swivel wheels
(provides more maneuverability in tight spaces, but less control when mobile)

LT-24 Options

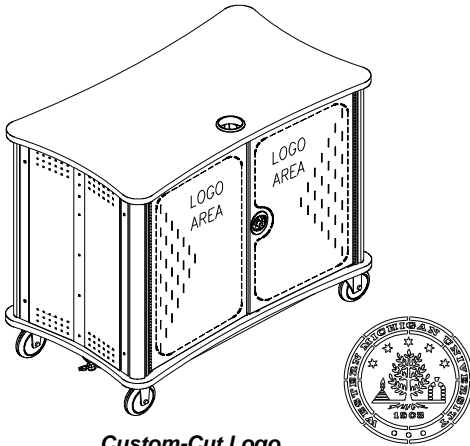

Custom-Cut Logo
 (Typical logo location-
 shown on student-side)
 55141

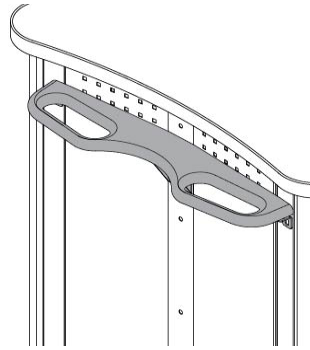

Second Handle
 20"W x 4"D
 (mounts on left or right)
 55171

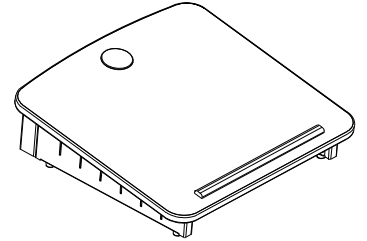

Lectern Riser
 18"W x 17¹³/₁₆"D
 95002



Replacement Key Set
 55142

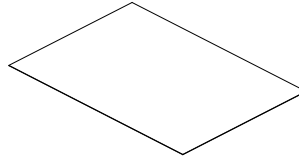

Non-Slip Pad
 24"W x 17"D
 95508

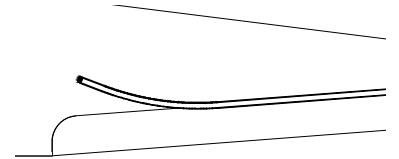

Tray Edge Trim
 30 pieces
 (applied to shelf pull edge)
 55172

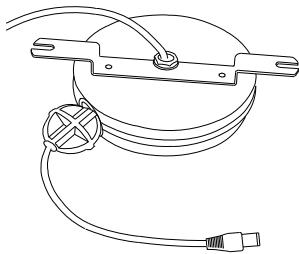

Data Cord Reel
 w/ 14' CAT 5 cord & plugs
 99026

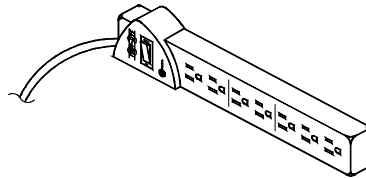

7-Outlet Power Strip, insured
 w/ surge protector, bracket, and 12' cord
 10"W x 2"D x 1¹/₈"H
 99024

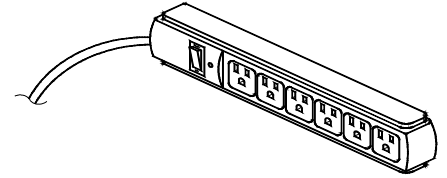

6-Outlet Power Strip
 w/ 12' cord
 11⁵/₁₆"W x 1¹/₁₆"D x 1³/₁₆"H
 99023

Warranty

WE WILL MAKE IT RIGHT FOR YOU!

Spectrum is committed to provide complete customer satisfaction. Each of our products are manufactured from the best materials available and each product is stringently monitored throughout the production process through our P.A.C.E. program (Product Assurance to meet Customer Expectations). Our Customer Service Help Line 1-800-235-1262 is ready to provide immediate attention to any questions, comments or concerns. We are available to answer your calls Monday through Friday from 7 am to 5 pm CST, excluding observed holidays. In addition your product comments or concerns are welcome via e-mail at: spectrum@spectrumfurniture.com.

Warranty Statement

We guarantee all Spectrum products to be free of all defects in materials and workmanship, for the original owner, for a period of ten years. Any item deemed defective by Spectrum or the original manufacturer, under normal use conditions, will be repaired or replaced at Spectrum's discretion. This warranty applies to all products manufactured and distributed by Spectrum except the products listed below.

Items that have a varying warranty include, but are not limited to, the following:

- Adjustable Crank/Electric Desk Legs (1 yr)
- Flat Panel Desk Gas Cylinders (1 yr)
- Upholstered Soft-Goods (5 yrs)
- Adjustable Height & Stacking Chair Parts – including frames, gas cylinders, wood and plastic parts, and control handles (7 yrs)
- Adjustable Height & Stacking Chair Casters (2 yrs)
- Chair Upholstery & Textiles (2 yrs of normal use of Soft Goods, Adjustable Height, Stacking, Wood and Metal Chairs)
- Chair Upholstery - Graded-In Fabrics and C.O.M (no warranty)
- Height Adjustable Columns and Lifts (1 yr)
- General Use Casters (1 yr)
- Electrical – Electri-Pak, Power Communication Modules, and special order ECA electrical items (1 yr)
- Electrical - Power Strips & Electrical Timers (1 yr)
- Electrical Surge Suppressors (lifetime)
- Electrical - Retractable Power Cords (1 yr)
- Keyboard/Mouse Trays (1 yr)
- Flat Panel Monitor Arm – General Parts (5 yrs)
- Flat Panel Monitor Arm – Gas Cylinders (2 yrs)
- CRT Monitor Arm (1 yr)

Warranty is void if product is not used for its intended purpose or subjected to an unusual application, multiple-shift use, alteration, accident, abuse or abnormal wear and tear. Representations of colors on-line and in printed materials are meant to be a close reference to the actual colors but not an exact match. Slight variations in color and texture of wood stains, powder coating, laminates, fabrics and other materials are normal in different manufacturing lots; as such these variations are not considered defects.

DESIGNED FOR INDOOR USE ONLY – Unless specifically stated in the product specifications, Spectrum's products have been designed and constructed for indoor use only. Moving or using outdoors, or on excessively rough surfaces, may cause damage to the products and will void the warranty. If an outdoor application is desired please contact us to discuss potential custom design solutions.

The warranty, as stated above, supersedes any previous warranties and is effective as of 9/1/2010

Touchboards

205 Westwood Ave, Long Branch, NJ 07740
Phone: 866-94 BOARDS (26273) / (732)-222-1511
Fax: (732)-222-7088 | E-mail: sales@touchboards.com



SCIENTIFIC CERTIFICATION SYSTEMS
SCS-IAQ-02352



SPECTRUM
INDUSTRIES INC.

925 First Avenue, PO Box 400, Chippewa Falls, WI 54729 Ph: 1-800-235-1262 Fax: 1-800-335-0473
E-mail: spectrum@spectrumfurniture.com web: www.spectrumfurniture.com