

# LT-24 Laptop Cart (H3)

55174

LT-24 w/ 5" balloon wheels

Choose (one) of the following designations and add to part #:

SR - 2 rigid, 2 swivel balloon wheels  
(provides more control when mobile)  
BW - 4 swivel balloon wheels

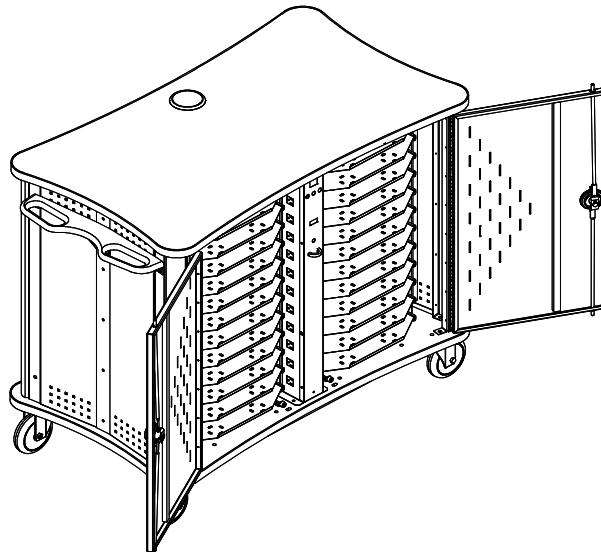
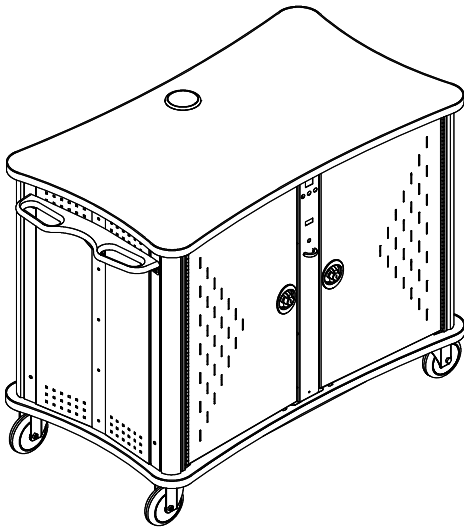

Holding up to 24 laptops, the LT-24 can support an entire classroom of laptops while providing secure storage and controlled recharging all in one. The design of the cart allows quick loading and unloading of laptops for the students due to two full columns of trays. The laptops lay flat on pull-out trays that allow the students to grasp the laptop with both hands, lessening the chance for damage.

## Features and Benefits

- Holds up to 24 laptops (12 on each side)
- 24 laptop trays pull-out from the front and back, providing quick-access to laptops and cables
- Four 5" locking balloon wheels roll easily and quietly on uneven surfaces
- One standard ergonomic handle provides control and mobility (can be mounted on either side)
- Standard 15' retractable 15-amp power cord reel provides quick and easy power-access
- Double-bolt, keyed locking front and rear doors provide security and easy-access
- Cycle charger with timer and conveniently-located power outlets provide easy charging
- 15-amp breaker on each circuit protects laptops from electrical overload.
- One seven-outlet insured power strip with surge-protector and 12' cord for additional peripherals
- Scratch and impact-resistant 1<sup>1</sup>/<sub>16</sub>" high-pressure laminate work surface
- Ventilated side and door panels help dissipate heat
- Cable grommets and wire management located in each tray keep wires and cords organized (Velcro tie-downs included)
- 3" covered grommet on work surface provides power strip access
- 1<sup>7</sup>/<sub>8</sub>"W x 3<sup>1</sup>/<sub>4</sub>"D rectangular grommet in bottom work surface provides access to cord reel
- Warranted to be free of all defects in materials and workmanship with a 10-year warranty

## Construction

- The work surface is constructed from 1<sup>1</sup>/<sub>16</sub>" thick industrial-grade composite board with .030 high-pressure laminate on one face, and a balancing phenolic backer on the opposing face
- Metal components consist of 16-gauge and 20-gauge steel
- 20-gauge steel pull-out laptop trays and side panels
- 16-gauge steel doors and corner columns
- Solid wood corner column trim
- Work surface edges are covered with 3mm vinyl
- Ergonomic handle is made of black recycled plastic
- All metal components are finished with a scratch-resistant powder coat epoxy
- Each LT-24 is factory-assembled (except for handle) w/ wheels, packaged, and shipped on its own skid

## Capacity

- Storage and charging capacity for up to 24 laptops
- Overall dimensions: 46<sup>5</sup>/<sub>8</sub>"W x 26"D x 38<sup>3</sup>/<sub>4</sub>"H
- Pull-out laptop tray dimensions: 16<sup>1</sup>/<sub>4</sub>"W x 20<sup>5</sup>/<sub>8</sub>"D x 2<sup>15</sup>/<sub>32</sub>"H
- The 5" balloon casters have a weight capacity of 325 lbs each (1300 lbs max total unit weight)
- 15' retractable 15-amp cord reel
- Meets or exceeds all ANSI-BIFMA test standards
- Features and specifications subject to change without notice
- **Unit weight (nominal):** 300 lbs
- **Shipping weight (nominal):** 345 lbs

# Touchboards

205 Westwood Ave, Long Branch, NJ 07740  
Phone: 866-94 BOARDS (26273) / (732)-222-1511  
Fax: (732)-222-7088 | E-mail: sales@touchboards.com

## Color Options

Standard laminate / Color combinations:

- Wild Cherry / Black (CHB)
- Indigo Organix / Dark Gray (ID)

Standard color combination refers to the quickest deliverable product color combination. Custom laminates and color combinations are available—additional lead-times and up-charges may apply. Call 800-235-1262 for further information.

**55174SR LT-24**

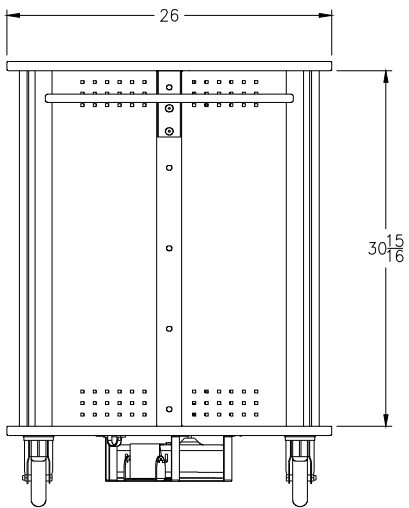
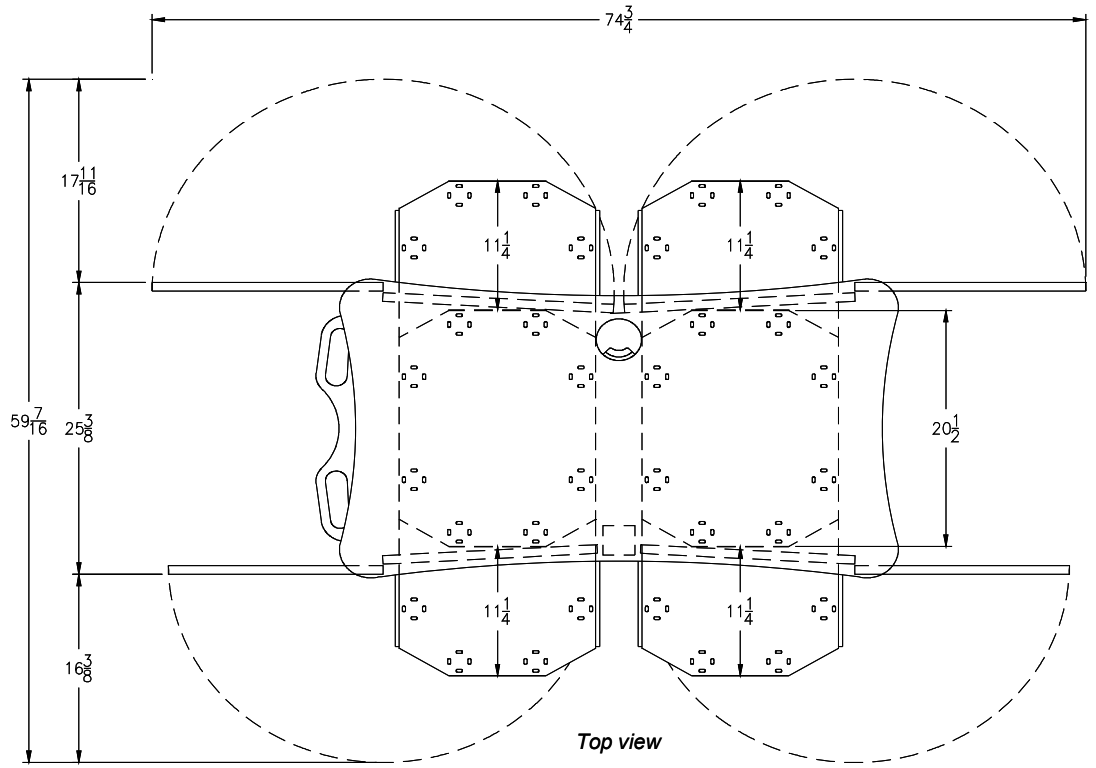

*Left-side view*

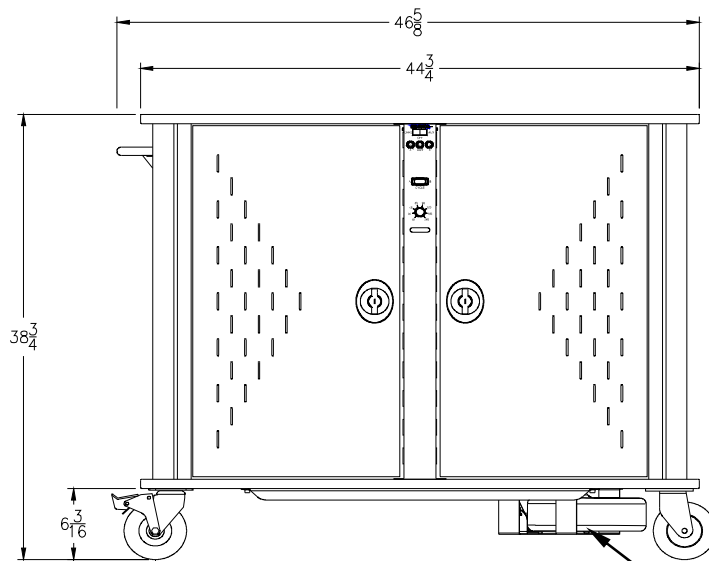

*Instructor-side view*

Standard 15' Cord Reel  
(15-amp)

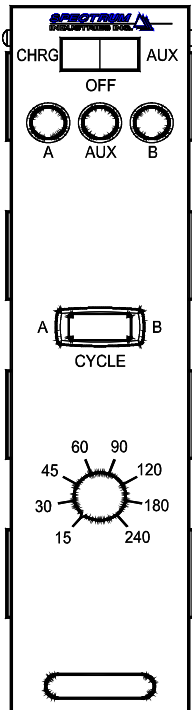

Cycle Charger

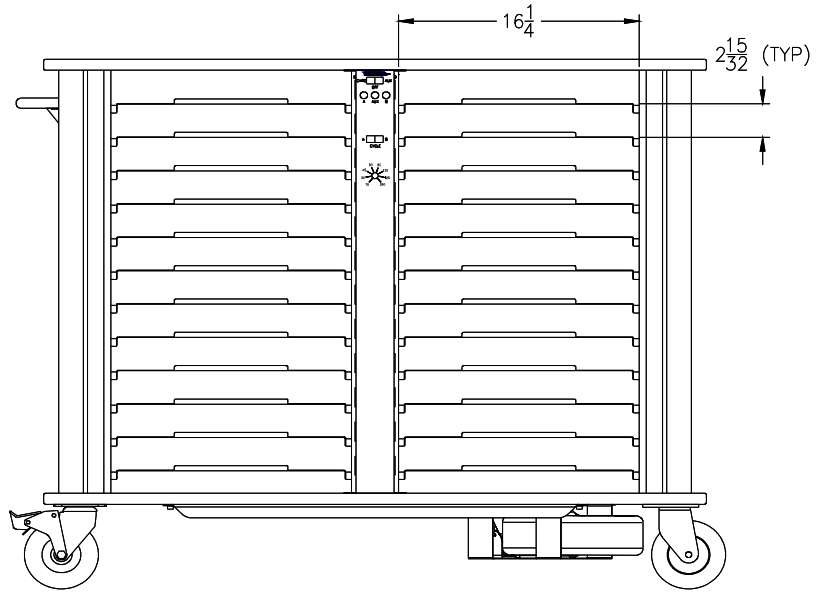

(shown without doors)

- The cycle charger intermittently charges two sets of up to 12 laptops (24 total) using a timed switch that provides accurate timed charging/switching and can be set between 15 and 240 minutes.

**Note:** Spectrum does not recommend charging more than 12 laptops at once, or modifying the cycle charger to charge more than 12 laptops at a time. Damage to electrical wiring, charging system, or laptops could result.

- 3-position, manual-override / cycle rocker switch with LED indicators switches between charging or auxiliary circuits (A,B-green, AUX-amber)
- 3-position, manual-override / cycle rocker switch switches charging between the A side, cycle charging, or B side
- 15-amp circuit breaker on each charging circuit (breakers protect the laptops from electrical overload)
- Wired with 14 AWG wire

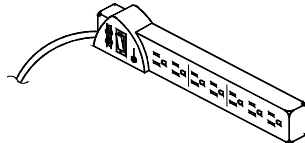

**Standard 7-Outlet Power Strip, insured**  
w/surge protector, bracket, and 12' cord  
10"W x 2"D x 1 1/8"H

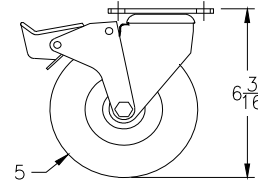

5" Balloon Wheel

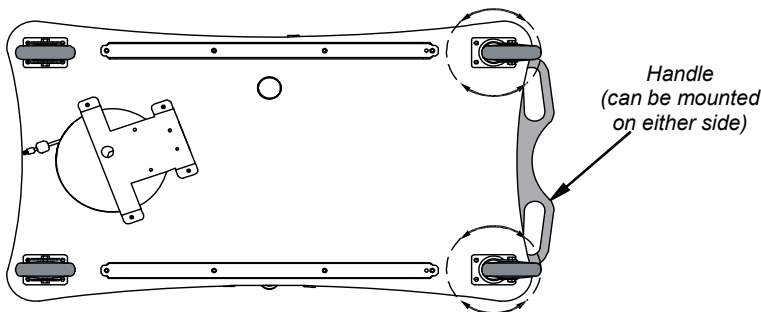
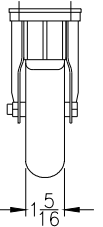

**(SR) = 2 rigid, 2 swivel wheels**  
(provides more control when mobile, but less maneuverability in tight spaces)

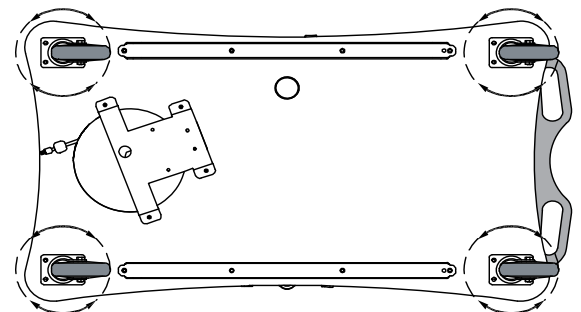

**(BW) = 4 swivel wheels**  
(provides more maneuverability in tight spaces, but less control when mobile)

**Note:** If you have the (SR) version (2 rigid, and 2 swivel wheels) on your particular cart, mounting the handle on the same side as the two swivel wheels will provide more control of the cart when mobile.

# LT-24 Options

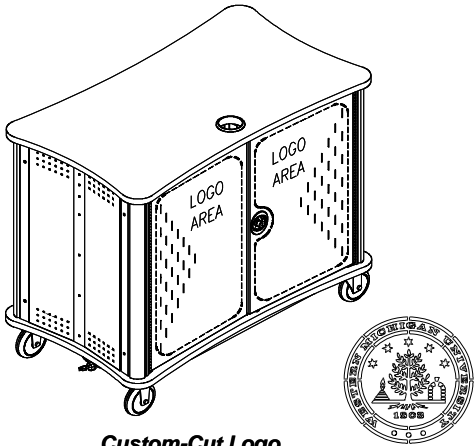

**Custom-Cut Logo**  
(Typical logo location-  
shown on student-side)  
55141

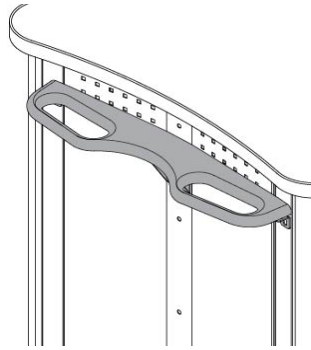

**Second Handle**  
20"W x 4"D  
(mounts on left or right)  
55171

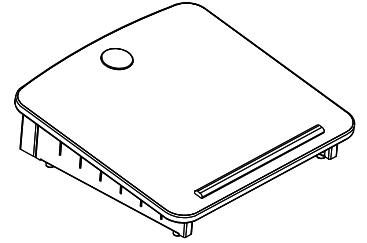

**Riser Podium**  
18"W x 17<sup>13</sup>/<sub>16</sub>"D  
95002



**Replacement key set**  
for double-bolt lock  
55142

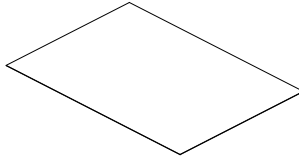

**Non-Slip Pad**  
24"W x 17"D  
95508

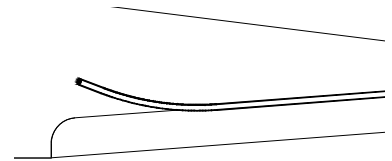

**Tray Edge Trim**  
30 pieces  
(applied to shelf pull edge)  
55172

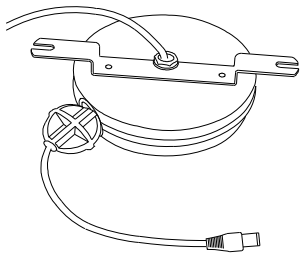

**Data Cord Reel**  
w/ 14' CAT 5 cord & plugs  
99026

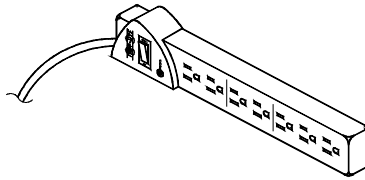

**7-Outlet Power Strip, insured**  
w/surge protector, bracket, and 12' cord  
10"W x 2"D x 1<sup>1</sup>/<sub>8</sub>"H  
99024

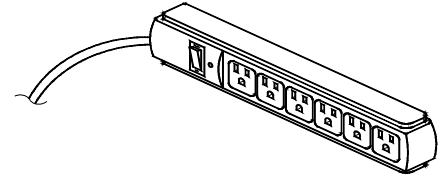

**6-Outlet Power Strip**  
w/ 12' cord  
11<sup>5</sup>/<sub>16</sub>"W x 1<sup>1</sup>/<sub>16</sub>"D x 1<sup>3</sup>/<sub>16</sub>"H  
99023

## Warranty

### **WE WILL MAKE IT RIGHT FOR YOU!**

We guarantee all Spectrum products to be free of all defects in materials and workmanship, for the original owner, for a period of **ten years**. Any item deemed defective by Spectrum or the original manufacturer, under normal use conditions, will be repaired or replaced at Spectrum's discretion. This warranty applies to all products manufactured and distributed by Spectrum except the products listed below.

**DESIGNED FOR INDOOR USE ONLY** - Spectrum's products have been designed and constructed for indoor use only. Moving or using outdoors, or on excessively rough surfaces, may cause damage to the products and may void the warranty. If an outdoor application is desired please contact us to discuss potential custom design solutions.

Spectrum is committed to provide complete customer satisfaction. Each of our products are manufactured from the best materials available and each product is stringently monitored throughout the production process through our P.A.C.E. program (Product Assurance to meet Customer Expectations).

Our Customer Service Help Line 1-800-235-1262 is ready to provide immediate attention to any questions, comments or concerns. We are available to answer your calls Monday through Friday from 7 am to 5 pm CST. In addition your product comments or concerns are welcome via e-mail at: [spectrum@spectrumfurniture.com](mailto:spectrum@spectrumfurniture.com).

Items that have a varying warranty include, but are not limited to, the following:

- Adjustable Crank/Electric Desk Legs (1 yr)
- Flat Panel Desk Gas Cylinders (1 yr)
- Adjustable Height Chair Parts – including frames, gas cylinders, wood and plastic parts, and control handles (7 yrs)
- Adjustable Height Chair Parts Casters (2 yrs)
- Adjustable Height Chair Upholstery - In-Stock Upholstery (2 yrs)
- Adjustable Height Chair Upholstery - Graded-In Fabrics and C.O.M (no warranty)
- Height Adjustable Columns and Lifts (1 yr)
- General Use Casters (1 yr)
- Electrical – ECA (1 yr)
- Electrical - Power Strips (1 yr)
- Electrical Surge Suppressors (lifetime)
- Electrical - Retractable Power Cords (1 yr)
- Keyboard/Mouse Trays (1 yr)
- Flat Panel Monitor Arm – General Parts (5 yrs)
- Flat Panel Monitor Arm – Gas Cylinders (2 yrs)
- CRT Monitor Arm (1 yr)

**The warranty, as stated above, is effective as of 05/28/2009**



205 Westwood Ave, Long Branch, NJ 07740  
Phone: 866-94 BOARDS (26273) / (732)-222-1511  
Fax: (732)-222-7088 | E-mail: [sales@touchboards.com](mailto:sales@touchboards.com)