

Technical Specifications

55495

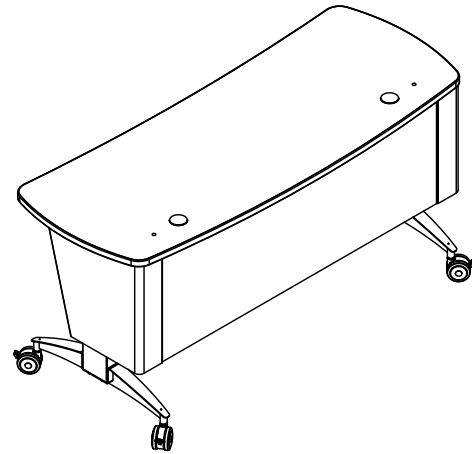
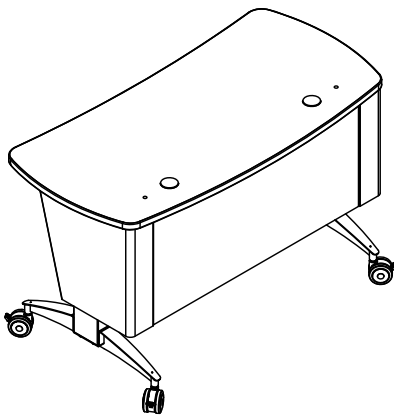
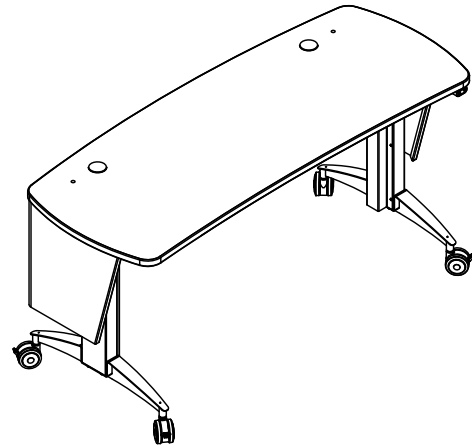
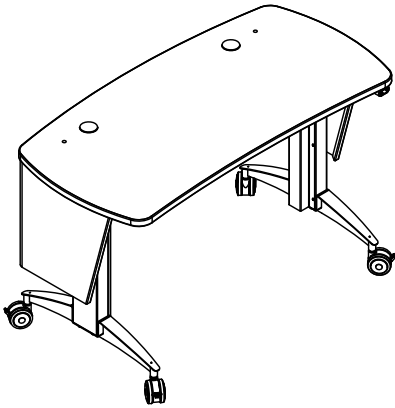

48"W Pivot Premier Workstation™

60"W Pivot Premier Workstation™

The sit-to-stand Pivot Premier Workstation™ was designed for today's integrated, active, higher-ed learning environments. This highly mobile unit has a large, height-adjustable, ADA-compliant worksurface and a wide variety of options to add versatility to any classroom.

Features and Benefits

- Electric telescoping legs adjust worksurface height from 28.5"-42"H
- Available in 48"W or 60"W versions
- Scratch and impact-resistant high-pressure laminate worksurface (also available in chalk white dry erase laminate)
- Durable powder coated steel chassis provides a long-lasting finish
- Worksurface vinyl edging protects walls and furniture
- Worksurface grommet provides cable access
- Twin-wheel casters provide easy mobility (all 4 locking)
- Optional 6RU rack kit
- Optional pull-out keyboard tray
- Optional CPU sling
- Optional worksurface power module
- Optional logo panel and laminate insert
- Optional rechargeable battery pack provides worksurface adjustability when mobile
- Ships KD (knocked down) and requires assembly
- Meets or exceeds applicable ANSI-BIFMA test standards
- Warranted to be free of all defects in materials and workmanship for 10 years
- Designed and assembled in Chippewa Falls, WI, USA

Color Options

Worksurface and metal available in Spectrum Expressions colors. See spectrumfurniture.com for complete color information.

Ordering Instructions

Spectrum has designed this workstation to receive the useful options shown here. To ensure your lectern and options are ordered correctly please call 1-800-235-1262.

Construction

- The worksurface is constructed from 1" thick NAUF (no added urea formaldehyde) composite board with .030" high-pressure laminate on one face, and a balancing phenolic backer on the opposing face
- Base components consist of 7-gauge steel
- Worksurface edges are covered with 3mm vinyl
- All metal components are finished with a scratch-resistant powder coat epoxy
- Each Pivot Premier Workstation ships KD (knocked-down) and requires assembly. Wiring is factory-installed, but leg cords need to be plugged into control box during assembly.

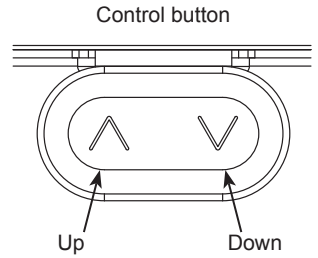

Specifications

Worksurface height adjustability (floor to top of worksurface)	42"H [106.7 cm] (fully-raised) 28.5"H [72.4 cm] (fully-lowered)
Max worksurface capacity	360 lb [163.4 kg]
Twin-wheel casters	<ul style="list-style-type: none"> • Diameter: 3" • Locking: all 4 casters • Weight capacity: 165 lb [75 kg] each
ADA-compliance*	<p>Knee clearance:</p> <p>48"W Workstation: 33"W [83.8 cm] x 19.4"D [49.3 cm] x 27.5"H [69.9 cm]</p> <p>60"W Workstation: 45"W [114.3 cm] x 19.4"D [49.3 cm] x 27.5"H [69.9 cm]</p> <p>(1 person per lectern)</p> <p><small>*Minimum ADA guidelines for knee clearances are 30"W [76.2 cm] x 19"D [48.3 cm] x 27"H [68.6 cm]</small></p> <p>Note: Worksurface with keyboard trays must be raised higher to provide ADA clearance. The workstation is ADA compliant with up to (1) CPU sling.</p>
Electrical	<ul style="list-style-type: none"> • Range of motion: 13.5" [34.3 cm] • ~10 seconds from fully-lowered to fully-raised • Inverter: 120V @ 60Hz, max output 300 watts • Motors: 18V / 10 amps • Typical electrical load during operation: 4.3 amps @ 120 VAC • Anti-collision protection <ul style="list-style-type: none"> • 8' [243 cm] nominal 3-wire power cord • Max load: 1200N (270 lb) [122.6 kg] per actuator • total lift capacity: 540 lb [245 kg] • Actuators feature non-hydraulic, permanently lubricated screw jacks • Actuators rated for 20,000 cycles • Approved according to EN 60335-1 and UL 962
Certifications / Compliance	<ul style="list-style-type: none"> • SCS Indoor Advantage Certified • Meets or exceeds applicable ANSI-BIFMA test standards
Unit weights (nominal)	N/A - 48"W N/A - 60"W
Shipping weight (nominal)	143 lb [65 kg] - 48"W 155 lb [70.4 kg] - 60"W

Specifications subject to change without notice

Configurations available

Worksurface width	Power option	Cutout option	Pull-out Keyboard Tray	Rack Rail	CPU Sling
48"W	None	None	Yes	None	Yes
48"W	None	None	None	Yes	Yes
60"W	None	None	(Choose 2)		
48" or 60"W	Any	None or custom	(Choose 1)		
48" or 60"W	None	Yes	(Choose 1)		

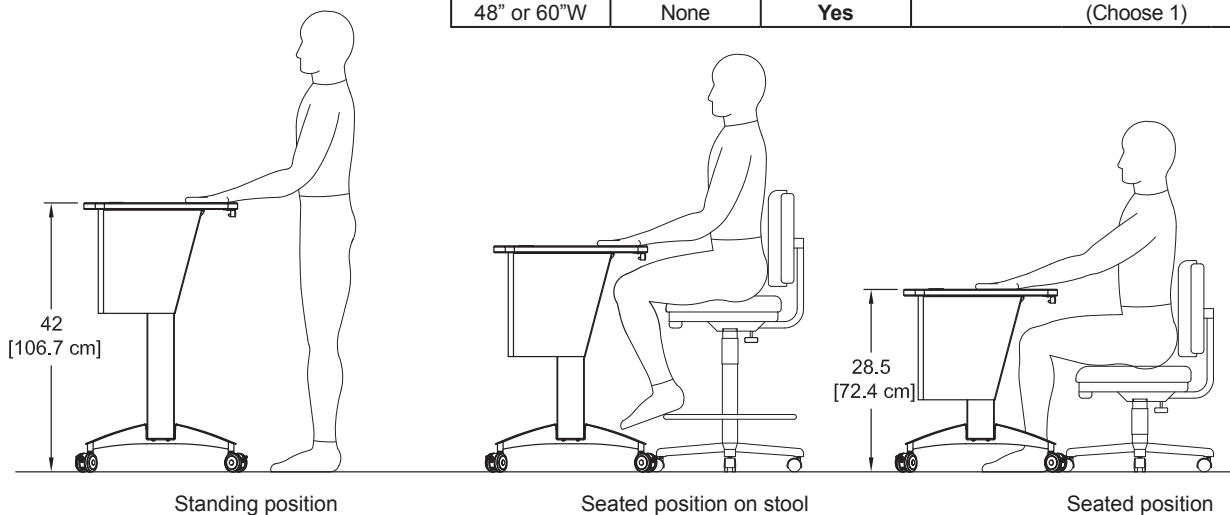

Accessory combinations & locations

Keyboard Tray + CPU sling

48"W

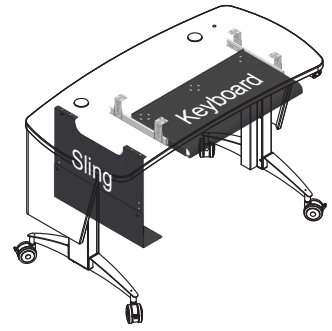
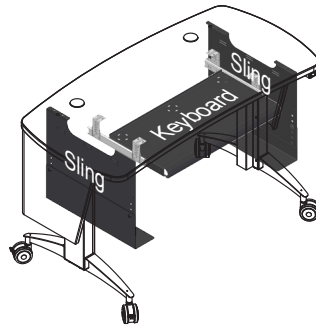
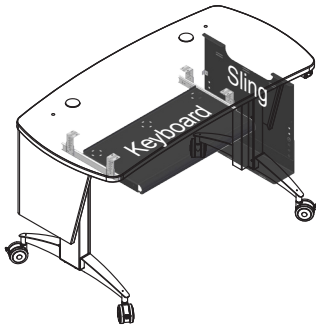

6RU Rack + CPU sling

48"W

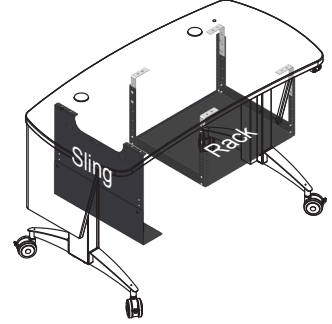
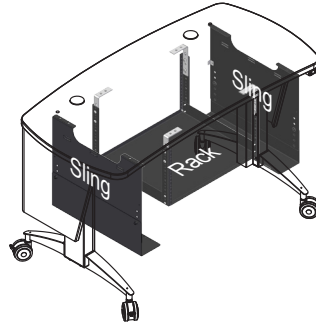
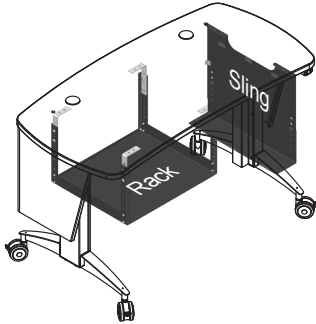

Keyboard Tray + CPU sling

60"W

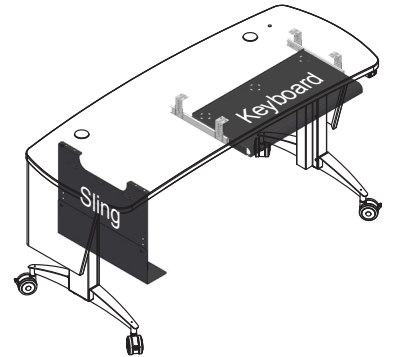
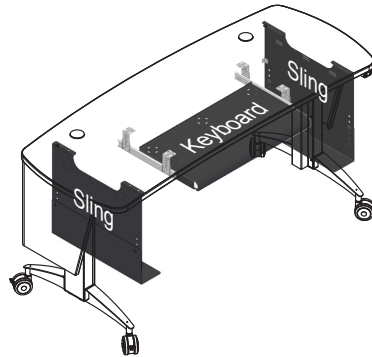
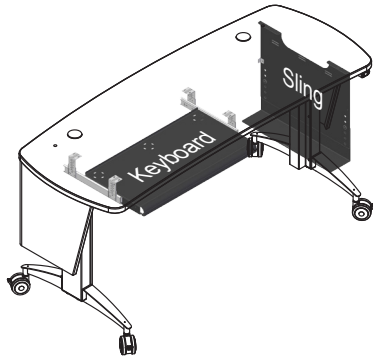

6RU Rack option + CPU sling

60"W

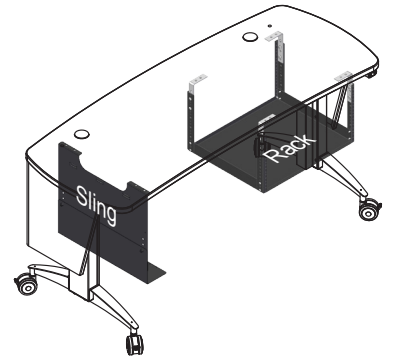
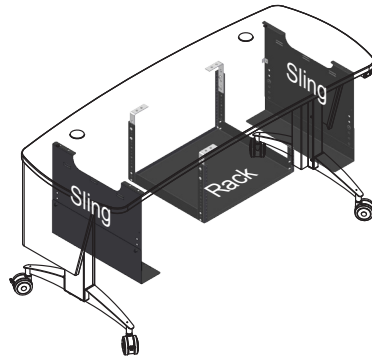
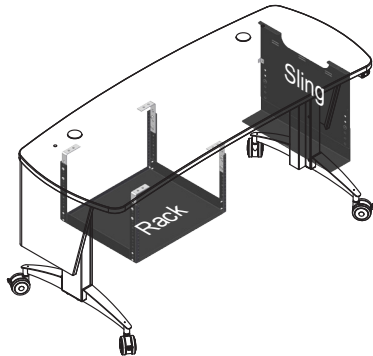

Keyboard Tray + 6RU Rack

60"W

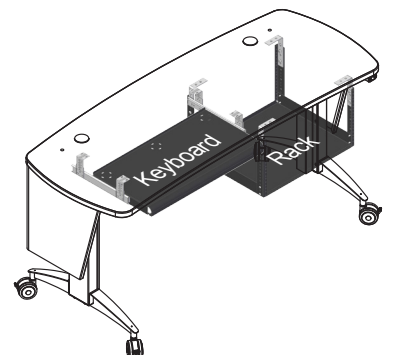
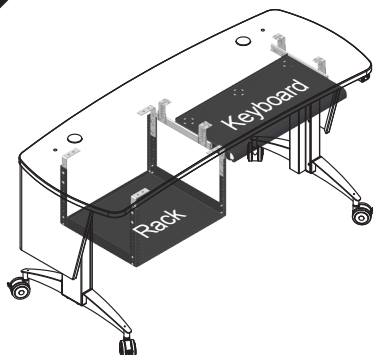

Worksurface width

ORDER CODE 1 = 48"W Worksurface

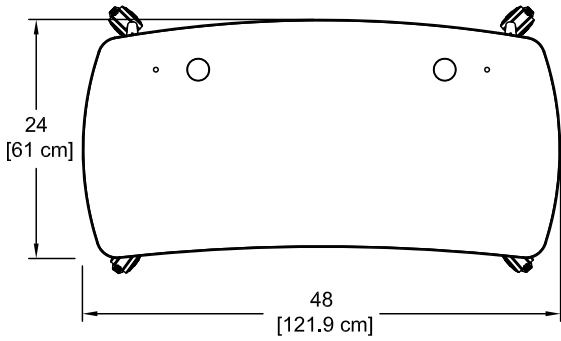

ORDER CODE 2 = 60"W Worksurface

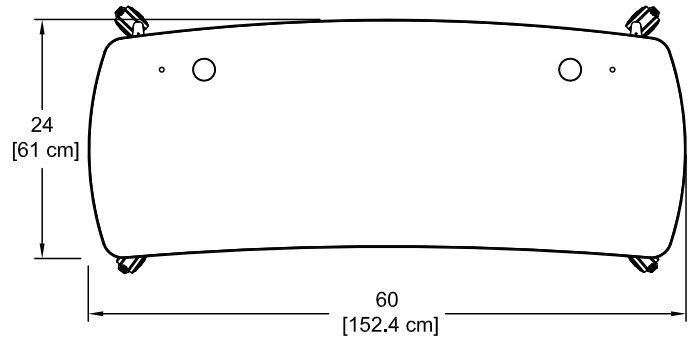

Mobility Options

ORDER CODE 1 = Glides

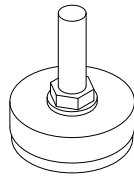

ORDER CODE 2 = Casters

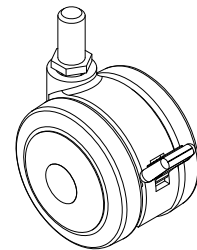

Power Options

ORDER CODE 00 = None

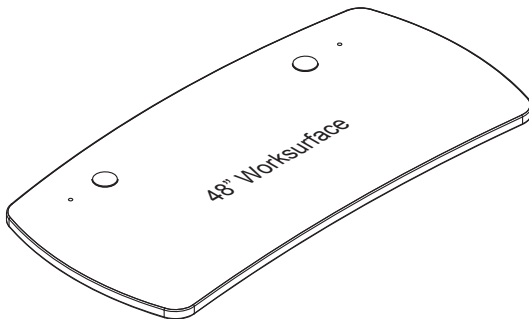

ORDER CODE 07 = EM Wireless Charging Pad

- Uses electromagnetic technology to charge Qi V1.2 compliant IC devices ("Qi" enabled)
- LED to confirm pairing / charging
- Security tab prevents theft
- Includes 3" round cutout
- UL-certified

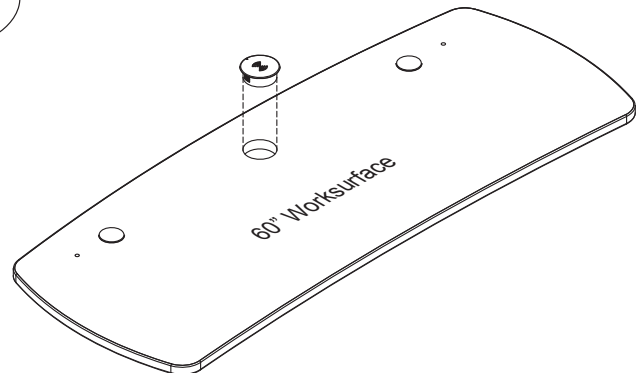
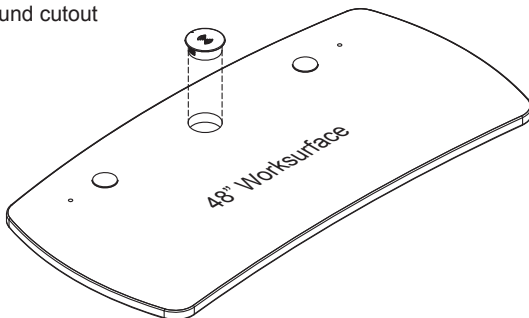
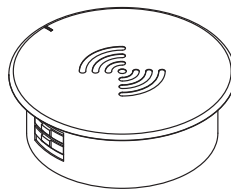

ORDER CODE 01 = Power Module - Black

ORDER CODE 02 = Power Module - Silver

ORDER CODE 03 = Power Module - White

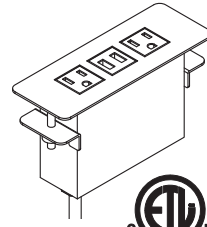

- Factory-installed
- (2) AC receptacles (tamper-resistant)
- (2) USB ports rated at 2.1A each (10.5 watts)
- Aluminum housing and flange
- 10' 14AWG *3C power cord
- When specified, the Power Module is centered on the audience-side edge of the worksurface
- Worksurface cutout size: 5.65"W x 1.65"D
- ETL-certified

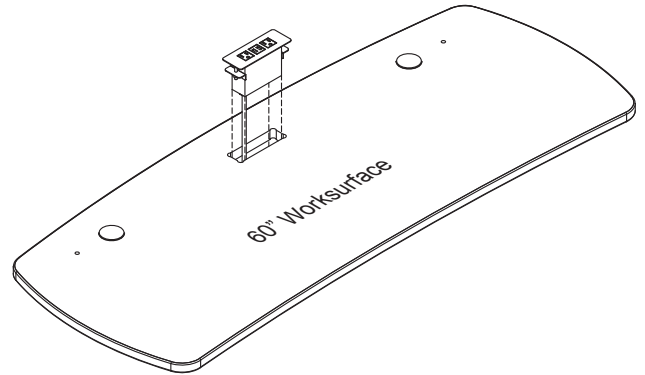
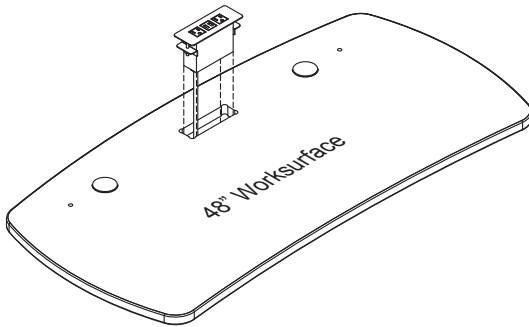

ORDER CODE 04 = Power Module - Black & EM Wireless Charging Pad

ORDER CODE 05 = Power Module - Silver & EM Wireless Charging Pad

ORDER CODE 06 = Power Module - White & EM Wireless Charging Pad

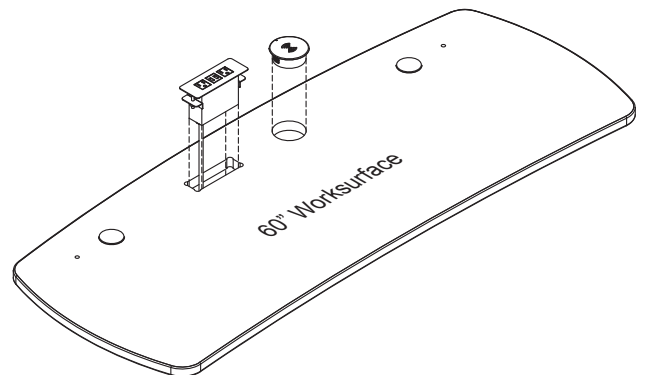
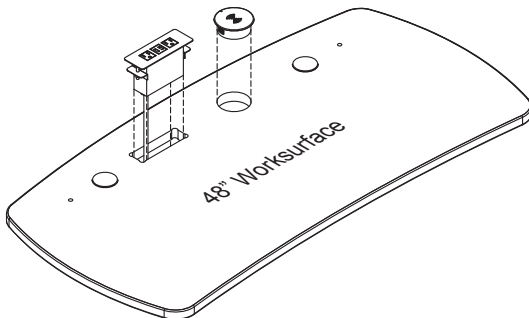
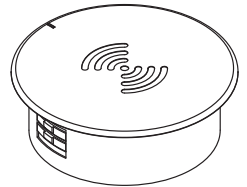
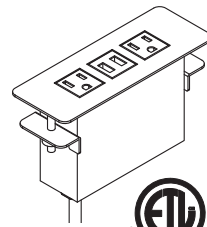

Cutout Options

ORDER CODE 00 = None

ORDER CODE 01 = Custom (contact Spectrum for size and location)

ORDER CODE 02 = Extron Cable Cubby 100

ORDER CODE 05 = Crestron TT-100 / 110

ORDER CODE 06 = Crestron TT-101 / 111

4" Round

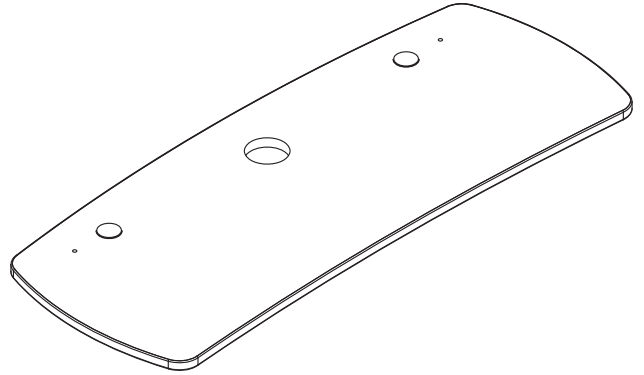
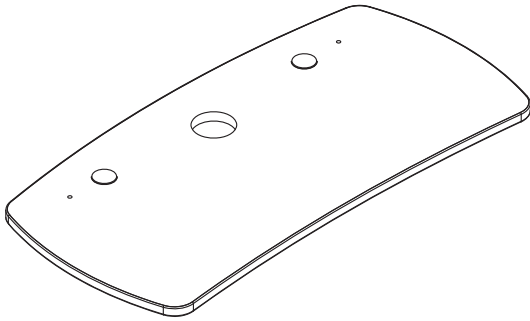
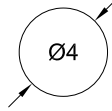

ORDER CODE 03 = Cable Cubby 202

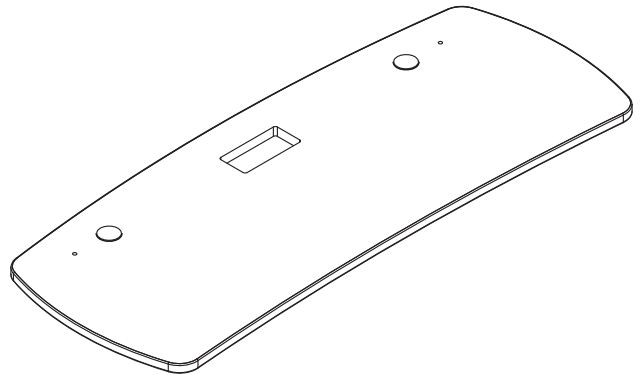
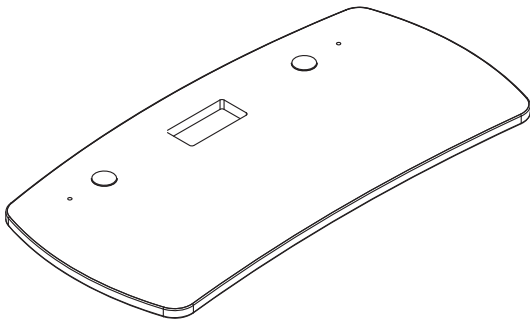
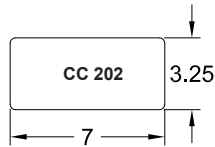

ORDER CODE 04 = Cable Cubby 500

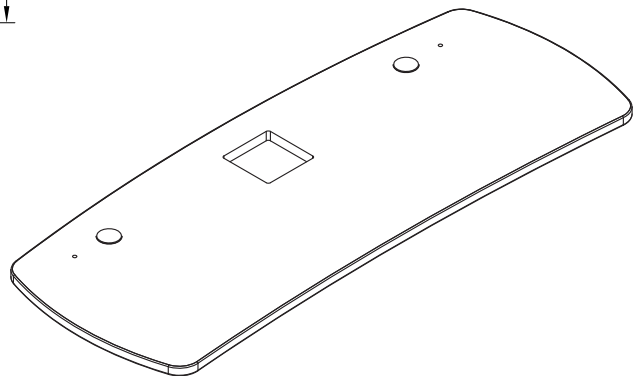
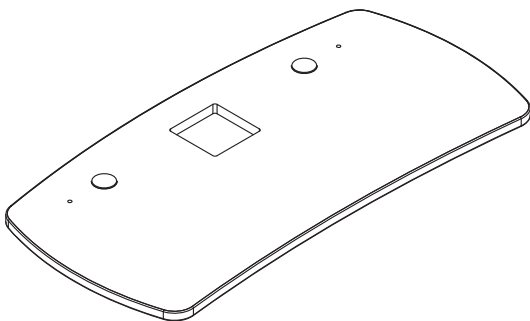
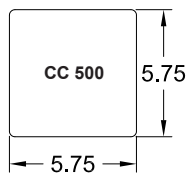

Keyboard Tray

ORDER CODE 0 = None

ORDER CODE 2 = Keyboard Tray (factory installed)

48"W Pivot Premier:

- Keyboard Tray + CPU sling
- 6RU Rack option + CPU sling

60"W Pivot Premier:

- Keyboard Tray + CPU sling
- 6RU Rack option + CPU sling
- Keyboard Tray + 6RU Rack option

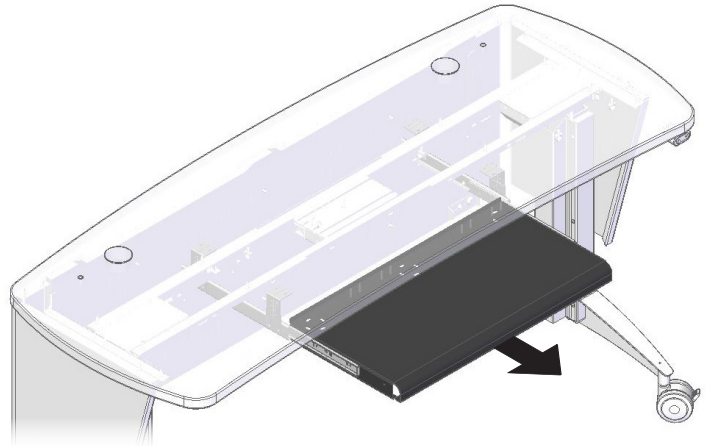

Rack Rail Option

ORDER CODE 0 = None

ORDER CODE 1 = 6RU Rack

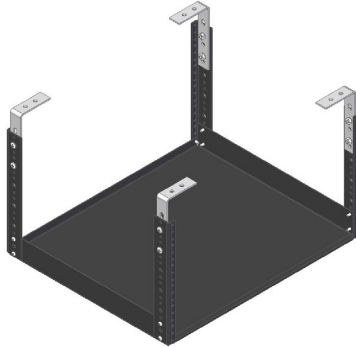

See p.3 for available accessory combinations and locations

CPU Sling

ORDER CODE 0 = None

ORDER CODE 1 = CPU Sling

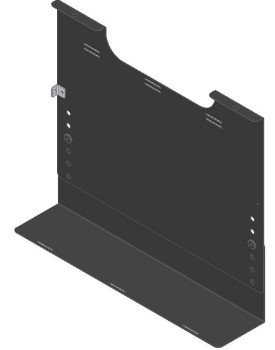

See p.3 for available accessory combinations and locations

Logo Panel Option

ORDER CODE 0 = None

ORDER CODE 1 = Custom logo w/ matching laminate backer

ORDER CODE 3 = Custom logo w/ black laminate backer

ORDER CODE 4 = Custom logo w/ white laminate backer

ORDER CODE 5 = Custom printed backer

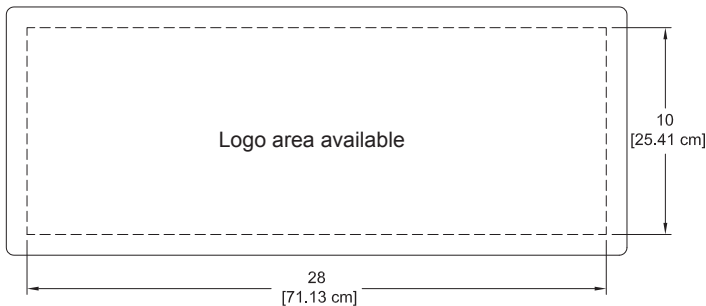
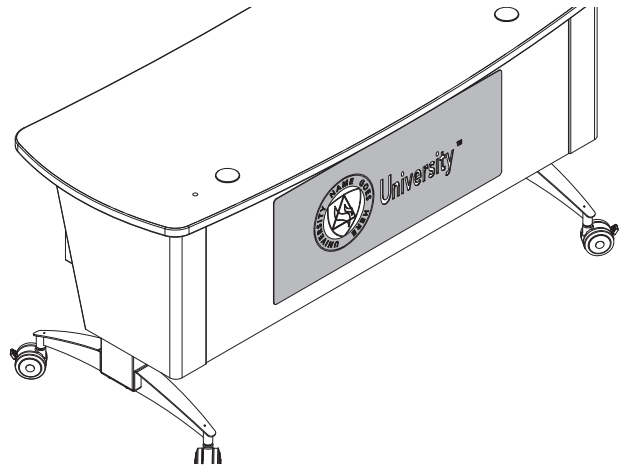

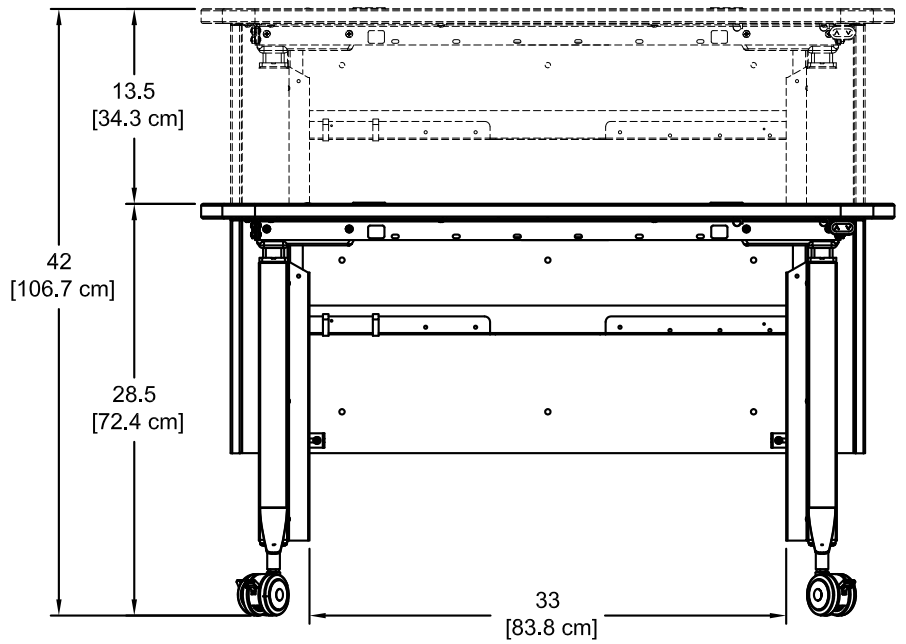
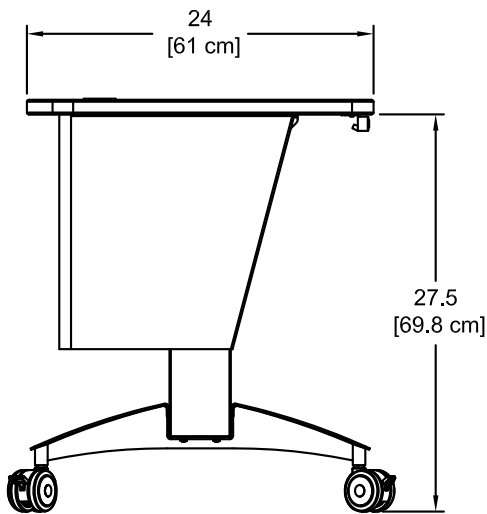
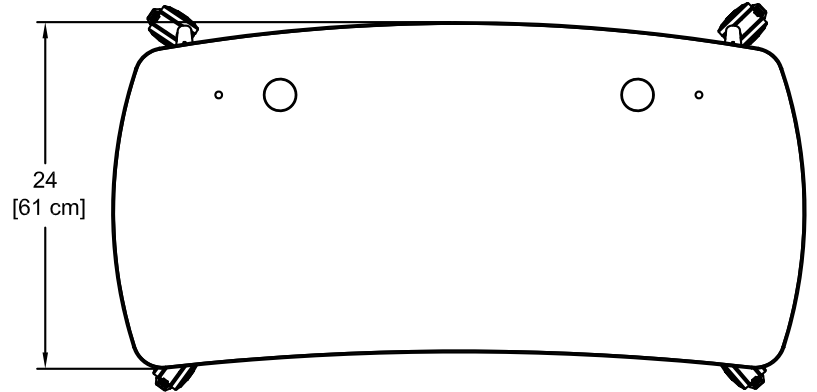
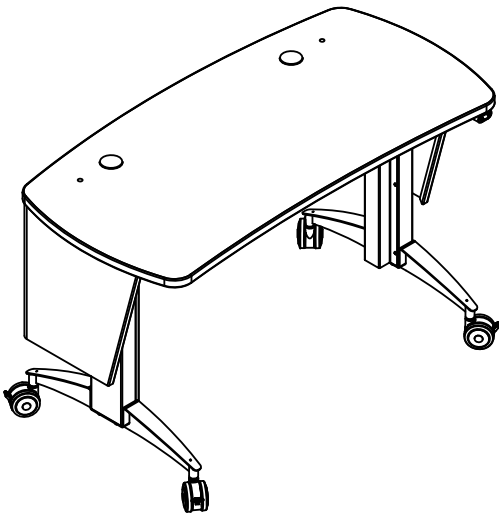

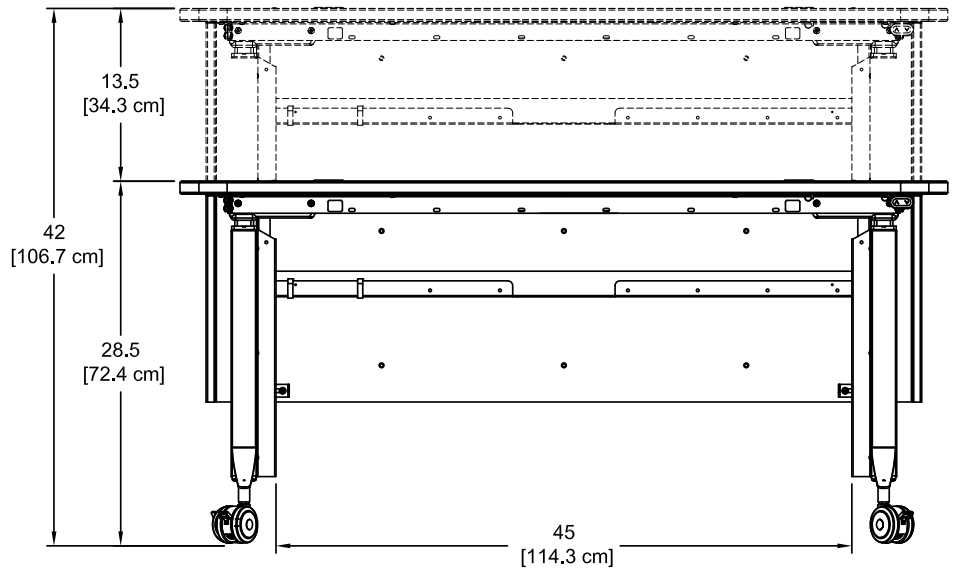
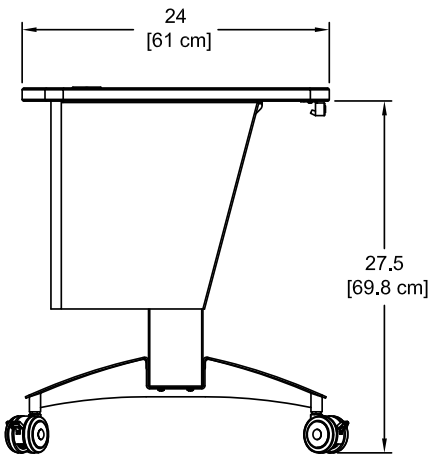
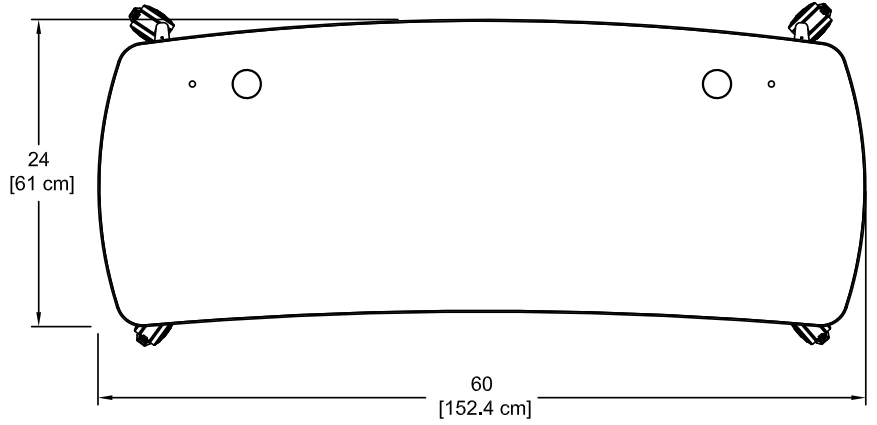
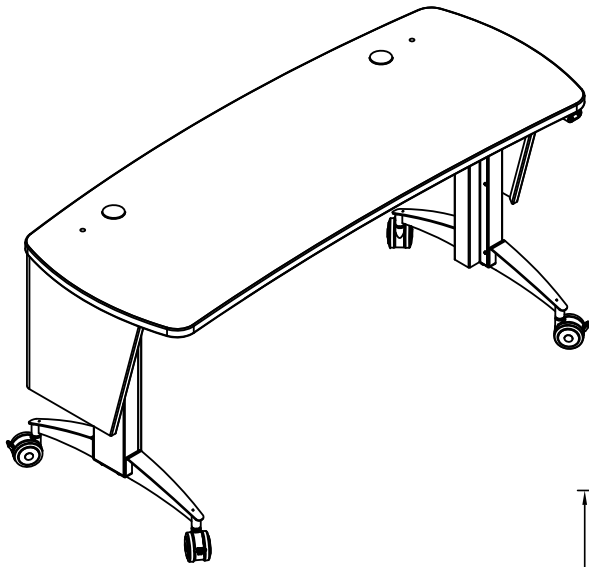

Max cutout area in worksurface
 (Optional keyboard tray, CPU slings,
 and rack rail shown in position)

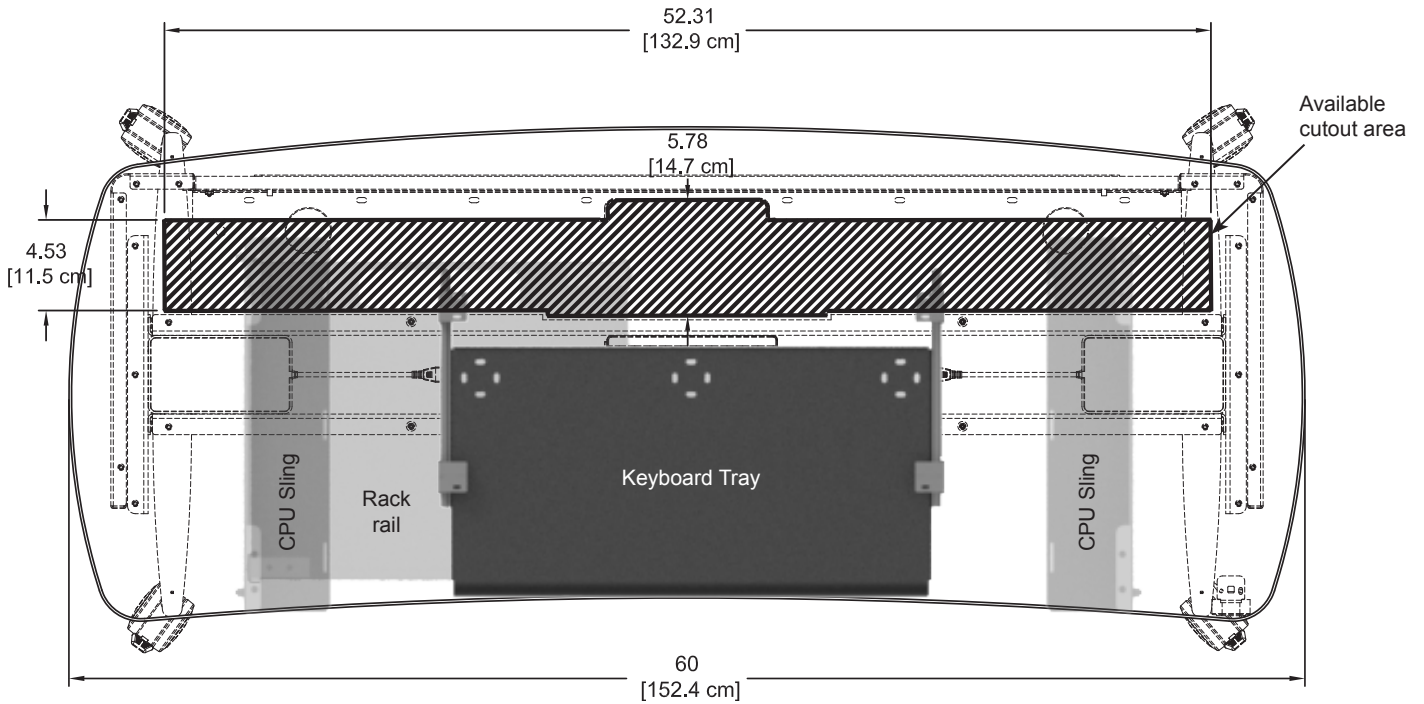
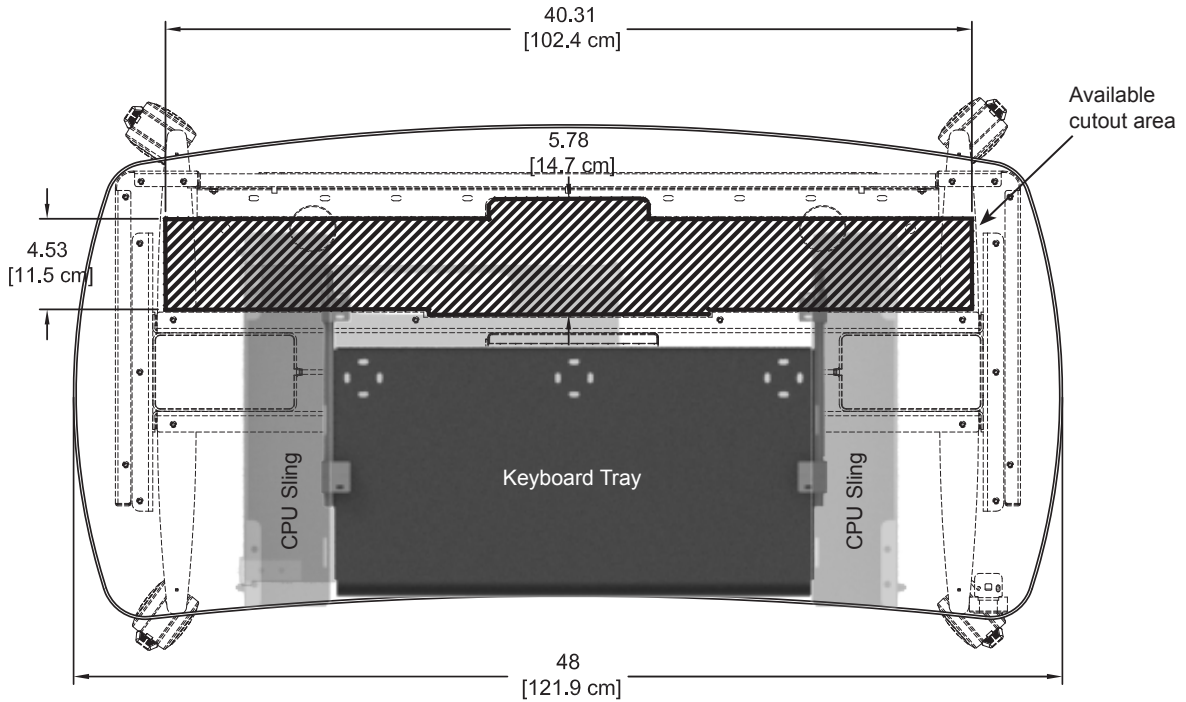

Note: Optional accessories (shown shaded) and their mounted position will effect final cutout locations. Custom cutouts should be reviewed by Spectrum to ensure clearance of brackets, keyboard slides, CPU slings, or other objects under the worksurface.

Please contact Spectrum (with preferred accessories & cutouts) for assistance with worksurface cutout placement.

Cutouts can be made in the blank insert panel by the customer after the lectern has been purchased, but are only recommended within the maximum cutout area shown.

Accessories

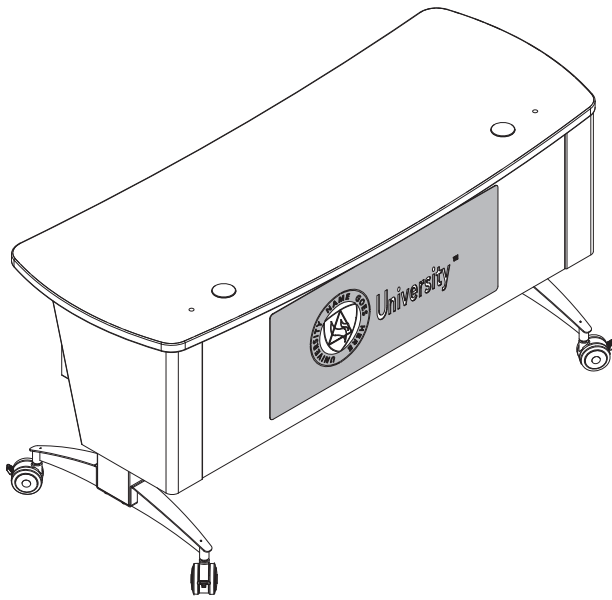

Customized Logo Panel - 55199

- Attaches to audience-side
- Available with black, white, matching, or printed laminate backer
- To get panel customized-contact Spectrum for details
- New logos require a first time logo charge
- Customer-installed

Dimensions:	30"W [76.2 cm] x 12"H [30.48 cm]
Available logo area:	28"W [71.1 cm] x 10"H [25.41 cm]
Unit weight:	6 lb [2.7 kg]
Shipping weight:	8 lb [3.6 kg]

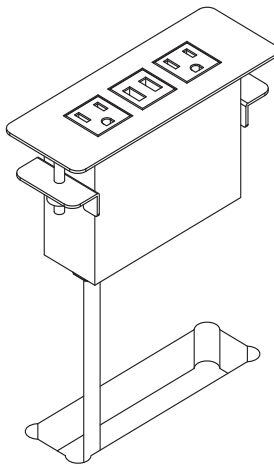
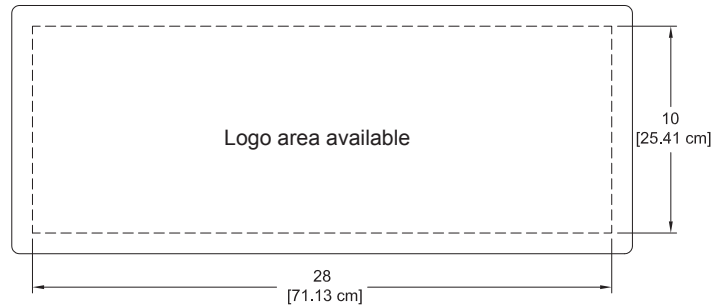

Power Module - 99058

- (2) AC power receptacles
- (2) USB charge ports
- Aluminum housing and flange
- Thumbscrew clamps
- Requires worksurface cutout made by customer
- ETL-certified
- Available in black, silver, or white
- Customer-installed



Cutout required:	5.65"W [14.35 cm] x 1.65"D [4.19 cm]
Power cord:	10' [305 cm] 14AWG *3C power cord
Power receptacles:	125V, 60hz, 15A tamper-resistant
USB charging ports:	2.1A (10.5W) (not data-compatible)
Dimensions:	6.38"W [16.2 cm] x 2.36"D [6 cm] x 3.54"H [9 cm]
Unit weight:	2 lb [.9 kg]
Shipping weight:	2.35 lb [1 kg]

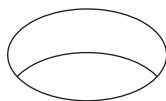

EM Wireless Charging Pad - 99057

- Uses electromagnetic technology to charge Qi V1.2 compliant IC devices ("Qi" enabled)
- LED to confirm pairing / charging
- Security tab prevents theft
- Customer-installed
- UL-certified

Cutout required:	3" dia (by customer)
Input:	DC 5V (with included DC5V.2A power adapter)
Output:	5W max (with included DC5V.2A power adapter)
Power cord:	8' [244 cm] with DC jack
Dimensions:	3.5" dia [8.9 cm] x 1.125"H [2.9 cm]
Shipping weight:	1 lb [.45 kg]

Note: The unit requires a 7" diameter of clearance to work with Qi-enabled phones placed in any orientation. The 3" dia cutout should be located on the worksurface at least 3.5" from any edge.

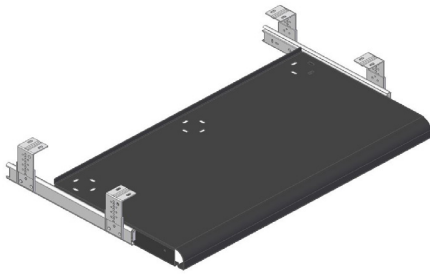

Pull-out Keyboard Tray - 55496

- 24"W [61 cm] x 11.625"D [29.5 cm] x 2.43"H [6.1 cm]
- 16 ga steel
- Shipping weight: N/A

Note: On the 48"W lectern, the keyboard tray is not compatible with the 6RU Rack option. On the 60"W lectern, the keyboard tray is compatible with (1) 6RU rack option or (1) CPU sling.



CPU Sling - 38982

- 4.25"W [10.8 cm] x 18.75"D [47.625 cm] x 14.125"-19.125"H [35.88 cm - 48.6 cm]
- 16 ga steel
- Black powdercoat
- Includes nylon straps
- Can be installed on left or right
- Unit weight: 7.5 lb [3.4 kg]
- Shipping weight: 8.5 lb [3.86 kg]

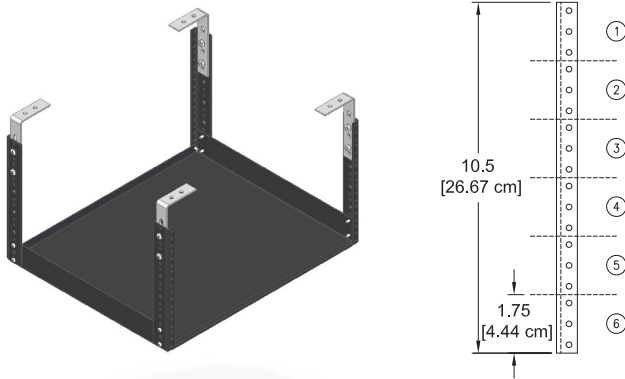

6RU Rack Kit - 38983

- 19.13"W [48.6 cm] x 16.29"D [41.4 cm] x 12.61"H [32 cm]
- Accepts standard rack equipment up to 16.038"D
- 16 ga steel
- Black powdercoat
- Shipping weight: 11 lb [5 kg]



Rechargeable Battery Pack System - 99045

- Creates a mobile lectern / desk by providing the ability to operate the unit in locations without AC power
- Compact, lightweight lithium-ion battery plugs into and charges from the existing lectern control box
- On-board LED light bars indicate charge capacity level
- Audio alarm signals when charging is needed
- Thermal switch protection, overcurrent protection
- Easy customer-installation

Battery Type	Lithium-ion
Capacity	2.2 Ah / 53 Wh
Voltage (nominal)	24V
Discharge current	9A (max)
Max charging voltage	40V DC
Charging current	0.5 A
Certifications	EN 62133 (Battery safety testing) UL 1642 (Lithium cells, standard test) UN 38.3 (Transportation of Lithium batteries) UL 2054 (Household and commercial batteries) EN 60335-1 with CBH Advanced
Unit weight: (nominal)	1.32 lb [.6 kg]
Shipping weight: (nominal)	2 lb [.9 kg]

Battery / Control Box Compatibility:

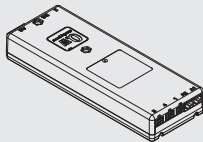

The CBD6S Linak control box is compatible with this battery pack.



Older CBD4 Linak control boxes are not compatible with this battery pack.



Flat Panel Monitor Arm

95512 - "Light-Duty" for monitors weighing 2-13 lb [.9-5.9 kg]

95522 - "Medium-Duty" for monitors weighing 7.5-25 lb [2.5-11.4 kg]

95509 - "Heavy-Duty" for monitors weighing 12-31 lb [5.4-14 kg]

- Six mounting options (clamp, thru-desk, wall, grommet hole, side bolt, reverse wall)
- Compatible with all VESA® monitors – includes 75mm and 100mm VESA® adapters
- Cable management concealed in arm



Dual Flat Panel Monitor Arm - 95533

- Weight range: 3.5-13 lb [1.6-5.9 kg] per monitor
- Six mounting options (clamp, thru-desk, wall, grommet hole, side bolt, reverse wall)
- Compatible with all VESA® monitors – includes 75mm and 100mm VESA® adapters
- Cable management concealed in arm

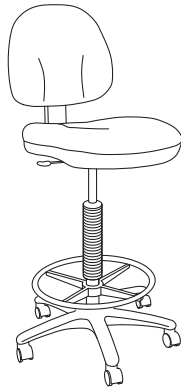

Adjustable Drafting Stool - 38202

- 40-52" height-adjustment via pneumatic cylinder
- 360° swivel
- Tilting backrest
- 18" diameter fixed foot ring
- 5-star base

Rack-mount Accessories

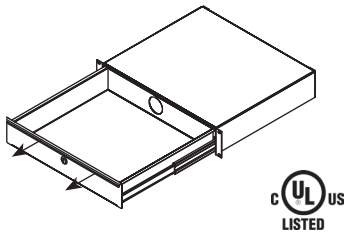

Locking Drawer - 2RU - 97523

- 16ga steel
- Drawer: 15.97"W [40.56 cm] x 14.56"D [36.98 cm] x 3"H [7.63 cm]
- Weight capacity: 50 lb [22.7 kg]
- Shipping weight: 15.85 lb [7.2 kg]

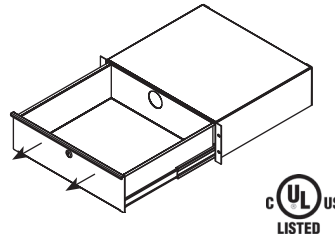

Locking Drawer - 3RU - 97522

- 16ga steel
- Drawer: 15.97"W [40.56 cm] x 14.56"D [36.98 cm] x 5.25"H [13.33 cm]
- Weight capacity: 50 lb [22.7 kg]
- Shipping weight: 18.5 lb [8.4 kg]

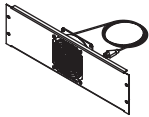

Single Fan - 3RU - 97507

- 50 cfm
- 120V~50/60 Hz, 15/13W
- RoHS
- 19"W [48.27 cm] x 1.56"D [3.97 cm] x 5.25"H [13.33 cm]
- Shipping weight: 3.78 lb [1.7 kg]

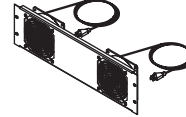

Double Fan - 3RU - 97506

- 100 cfm
- 120V~50/60 Hz, 15/13W
- RoHS
- 19"W [48.27 cm] x 1.56"D [3.97 cm] x 5.25"H [13.33 cm]
- Shipping weight: 5.47 lb [2.5 kg]

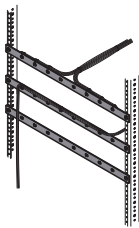

Wire Lace Kit - 95517

- Provides wire management
- Mounts to standard rack rails
- Includes (3) lace straps and mounting screws
- Includes (12) 5.5" zip ties
- Shipping weight: 1.25 lb [.57 kg]

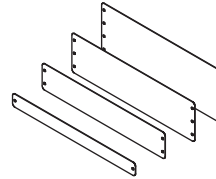

Rack-Mount Blanks

- 1RU - 97510**
- 2RU - 97511**
- 3RU - 97512**
- 4RU - 97513**

- Fills rack spaces where components are not needed
- 16 ga steel
- Shipping weight: <1 lb [.45 kg]

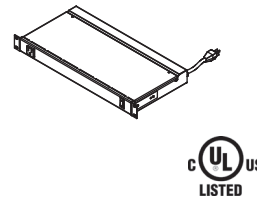

9-Outlet Power Strip - 1RU - 99021

- 8 outlets rear (breaker-protected)
- 1 convenience outlet front
- 115VAC, 60 Hz, 15 amps max
- 9' power cord
- Front LED power switch
- Enhanced surge protection
- ETL-listed, UL-listed
- 19"W [48.27 cm] x 9.25"D [23.5 cm] x 1.74"H [4.41 cm]
- Shipping weight: 8.7 lb [3.9 kg]

Warranty

We will make it right for you!

Spectrum is committed to provide complete customer satisfaction. Each of our products is manufactured from the best materials available and each product is stringently monitored throughout the production process through our Quality Management System.

We expressly warrant that Spectrum products will be of good quality and workmanship and free from defect for the period set out in the warranty table below from the date of delivery. This warranty shall not apply to defects or damage resulting from normal wear and tear, misuse, or unintended use, failure to follow instructions related to the product's installation or intended use, abuse, neglect, improper care, modification or repair not authorized by Spectrum, or any other cause outside the control of Spectrum. Spectrum will, at its sole option, either repair or replace the defective product.

This warranty is exclusive; no other warranty, written or oral, is expressed or implied. This warranty is given by Spectrum to Buyer or Buyer third party end user and to no other person or legal entity. No Spectrum dealer, distributor, partner, reseller, agent or employee is authorized to make any modification or addition to this warranty.

NOTWITHSTANDING ANYTHING TO THE CONTRARY, SPECTRUM WILL NOT UNDER ANY CIRCUMSTANCES BE LIABLE FOR INDIRECT OR LIQUIDATED DAMAGES, INCLUDING CONSEQUENTIAL, INCIDENTAL AND SPECIAL DAMAGES. IN NO EVENT SHALL SPECTRUM'S LIABILITY, WHETHER UNDER CONTRACT OR WARRANTY, IN TORT OR OTHERWISE, EXCEED THE PURCHASE PRICE RECEIVED BY SPECTRUM FOR THE PRODUCT AT ISSUE AND "RECALL ACTION" EXPENSES. SPECTRUM SHALL NOT BE SUBJECT TO ANY OTHER OBLIGATIONS OR LIABILITIES, WHETHER ARISING OUT OF BREACH OF CONTRACT, WARRANTY, TORT (INCLUDING NEGLIGENCE AND STRICT LIABILITY) OR OTHER THEORIES OF LAW, WITH RESPECT TO PRODUCTS SOLD OR SERVICES RENDERED BY SPECTRUM, OR ANY UNDERTAKINGS, ACTS OR OMISSIONS RELATING THERETO.

Our Customer Service Department is ready to provide immediate attention to any questions, comments or concerns. They are available to answer your calls Monday through Friday from 7 am to 5 pm CST. In addition your product comments or concerns are welcome via e-mail at: spectrum@spectrumfurniture.com.

Warranty Table

Item	Warranty Period
Desk, table, cart and lectern chassis	10 Years
Electrical	2 Years
Flat panel monitor arms / gas spring / general parts	2 Years
Adjustable crank / electric legs and accessories	2 Years
Flat panel desk gas spring cylinders	2 Years
Height adjustable columns, lifts & accessories	2 Years
Casters & wheels	2 Years
Keyboard, mouse, trays	2 Years
Locks & keys	2 Years
Tubs, totes and other accessories	1 Year
Chairs	7 Years
Structural components, including gas cylinders, wood, metal and plastic parts (i.e., chair frames, bases and control handles)	
Consumable items (i.e., casters, glides, etc.)	
In-stock upholstery	5 Years
Customer supplied material	No Warranty

