

# Assembly Instructions:

To purchase parts or accessories, please contact us at  
[www.spectrumfurniture.com](http://www.spectrumfurniture.com)  
 1-800-235-1262  
 Thank you for choosing Spectrum products!

## 37250 - 48" Round Table

(4) 037779  
5/16-18 Glide

(16) 026064  
1/4-20 x 5/8" PHMS

## 37251 - 24"D Half-Round Table 37252 - 30"D Half-Round Table

(3) 037779  
5/16-18 Glide

(16) 026064  
1/4-20 x 5/8" PHMS

(2) 037749  
Unit-to-unit brackets

(4) 0103920  
1/4-20 x 1/2" Thumbscrews

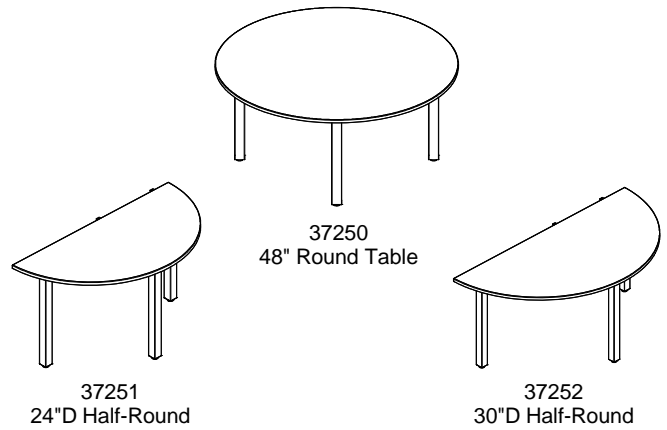

## Flex Training Tables

37250 - 48" Round  
 37251 - 24"D Half-Round  
 37252 - 30"D Half-Round

Before you begin, please make sure all parts and proper quantities are included. Any parts damaged during shipment must be reported within 15 days of receipt. To report information regarding damages or if you have any questions, please call 1-800-235-1262.



(1) 025069  
Glide wrench

Tools Required:  
 Phillips screwdriver  
 Glide wrench (included)

## Table Assembly

- Place work surface face-down onto a non-abrasive surface.
- Attach the legs to the work surface using 1/4-20 x 5/8" PHM screws and tighten securely. **Figure 1.**
- Attach the glides to the legs. Tighten securely with glide wrench.
- Carefully flip the table upright-this may require two people.

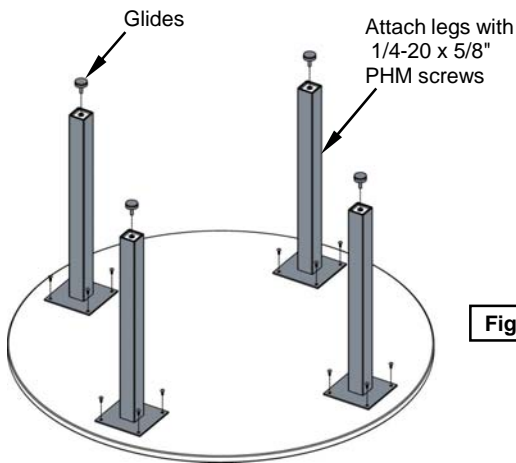

Figure 1



# Touchboards

205 Westwood Ave, Long Branch, NJ 07740  
 Phone: 866-94 BOARDS (26273) / (732)-222-1511  
 Fax: (732)-222-7088 | E-mail: sales@touchboards.com

## Connecting Half-Round Tables

- Arrange the tables side-to-side in the preferred location.
- Attach the unit-to-unit brackets to both table work surfaces as shown with 1/4-20 x 5/8" PHM screws and tighten securely. **Figure 2.**

**Note:** For stability reasons, half-round tables are designed to be connected to adjacent tables and are not recommended for stand-alone use. If a more temporary arrangement is preferred, the easily removable 1/4-20 thumbscrews can be used on the unit-to-unit brackets instead of Phillips screws.

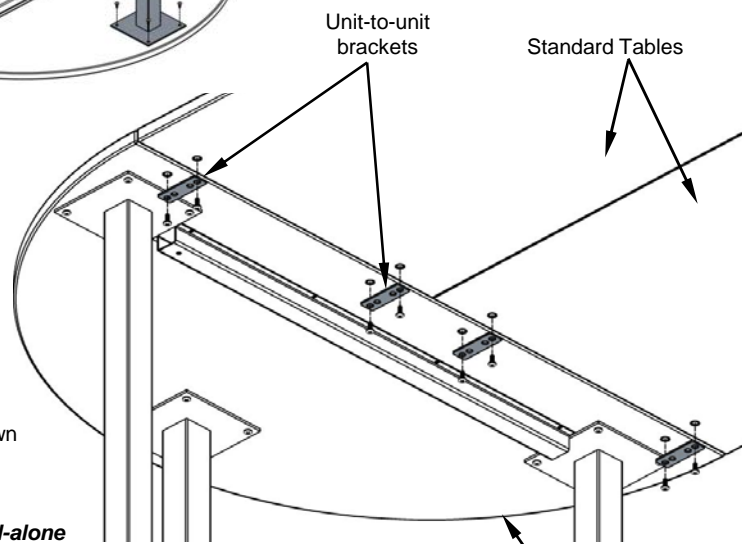

Figure 2

**SPECTRUM**  
INDUSTRIES INC.

925 First Avenue, PO Box 400, Chippewa Falls, WI 54729 Ph: 1-800-235-1262 Fax: 1-800-335-0473

E-mail: [spectrum@spectrumfurniture.com](mailto:spectrum@spectrumfurniture.com) web: [www.spectrumfurniture.com](http://www.spectrumfurniture.com)