

Technical Specifications

Touchboards 55493
205 Westwood Ave, Long Branch, NJ 07740
Phone: 866-94-BOARDS (26273) / (732)-222-1511
Fax: (732)-222-7088 | E-mail: sales@touchboards.com

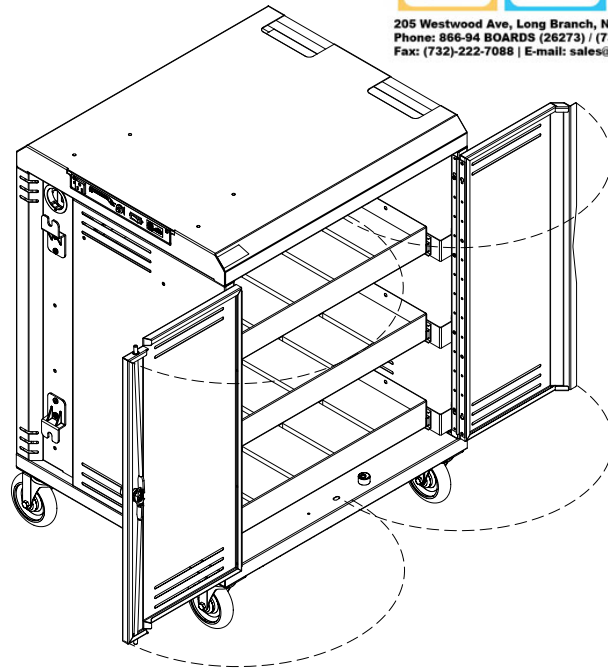

Use the VR Cart to store, transport, and charge up to 30 virtual reality devices. Two charging options are available. Protective foam on a pull-out tray protect and provide easy access to the devices. The cart's compact footprint and top handles provide easy mobility. Locking doors and panel increase security. This economical cart is made with heavy-gauge steel for security and powder-coated for a durable, long-lasting finish.

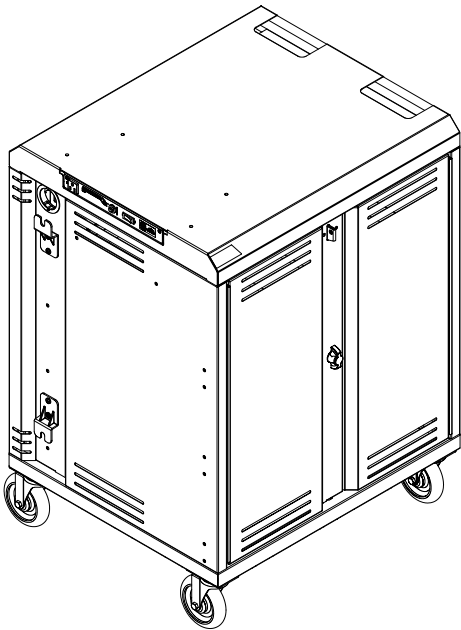

Features and Benefits

- Stores, charges, and transports up to 30 sets of VR goggles and phones
- Drawer storage supports quick and easy goggle storage and deployment
- Safety mechanism allows only one drawer to be pulled out at a time
- Polyethylene foam padding protects devices
- Stores most goggles up to 4.45"W x 9.125"D x 7.474"H
- .5"W x 7"D x .75"H foam slots fit most phones
- Internal shelf stores wifi router and instructor tablet (internal and external AC outlets available)
- Cord management system keeps charge cords organized at each drawer
- Small cart footprint (29"W x 25"D) saves valuable space
- Recessed lock and cord wrap design eliminates damage through doorways
- Heavy gauge student-side doors feature a recessed dual-bolt steel lock with padlock hasp. (Padlock not included)
- Heavy gauge instructor-side panel has a recessed padlock hasp for security. (Padlock not included)

- Four inboard 5" balloon wheel plate casters (two locking, two non-locking) with metal construction and non-marring rubber provide easy rolling, and quiet transport (rated for 300 lb each)
- Integrated handles in top panel provides control and maneuverability
- Cart ships fully-assembled for quick, simple integration and deployment
- Durable powder coated steel chassis provides a long-lasting finish
- ETL recognized (certified to UL 60950-1) in the US and Canada for the cart and electrical system
- Warranted to be free of all defects in materials and workmanship for 10 years, electrical system 2 years
- Designed and assembled in Chippewa Falls, WI, USA

Available with:

- PowerProdigy™ charging system that senses current from three, 10-outlet power units and distributes power (up to 10A) to the least-charged devices first (where charging is needed most). **For power adapters up to 65 watts**
- Available with power switch which provides continuous power to all three 10-outlet power units (non current-sensing). **For power adapters up to 45 watts**

- Three horizontal (125V~/12A, 60Hz) 10-outlet AC power units (1 per drawer)
- External main power switch provides easy-access for safe power connection / disconnection
- External LED illumination on timers indicate charge status while doors are closed (PowerProdigy™ timer only)
- Ventilated doors and side panels keep devices and chargers cool, preventing overheating, and extending device life
- Replaceable, IEC (quick-release) 8' nominal 14 AWG, 3-wire power cord and external recessed cord wrap brackets provide easy power access

VR30

<p>Inline outlets (Use with inline charge adapters)</p> <p>55493-DBQ - PowerProdigy™ 55493-DBR - Power Switch</p>	<p>Rotated outlets (Use with wall or inline charge adapters)</p> <p>55493-DBV - PowerProdigy™ 55493-DBW - Power Switch</p>
<p>55493-DBS - Power Switch-no power strips (for storage use only, or for customer-supplied USB power)</p>	

Color Options Warm Gray Black (top panel)

Construction

- 16-gauge top cover
- 20-gauge doors, side panels, power-side panel, and base
- All metal components are finished with a scratch-resistant powder coat epoxy
- Medium density, closed cell, crosslinked polyethylene protective foam in drawers (grey color)
- This cart is factory-assembled, packaged, and shipped on its own skid

Specifications

Capacity	30 devices	
Drawer capacity (nominal)	<ul style="list-style-type: none"> • 4.45"W x 9.125"D x 7.474"H - (goggle storage) • .5"W x 7"D x .75"H (phone slots) • Max weight per drawer : 25 lb [11.35 kg] 	
Electrical	<ul style="list-style-type: none"> • Three 10-outlet power strips (one per drawer) • 125V~/12A, 60Hz • 15-amp breaker 	<ul style="list-style-type: none"> • IEC quick-release (replaceable) 8' nominal, 14 AWG, 3-wire power cord • ETL recognized (certified to 60950-1)
Charging options (See p.4 for specs)	<p>⚠ Note: The customer should be aware of the amp draw of the devices used with this cart-especially when maxing out the storage and charging capacity. Exceeding 15 amps will trip the circuit breaker. Please consult the owners manual of your specific device for power consumption information.</p>	
5" Balloon Wheels	Weight capacity 300 lb [136.2 kg] each (two locking, two non-locking)	
Certifications / Compliance	• ETL recognized	• Meets or exceeds applicable ANSI-BIFMA test standards
Unit weight (nominal)	139-145 lb [63.1-65.8 kg]	
Shipping weight (nominal)	166-172 lb [75.4-78.1 kg]	

Specifications subject to change without notice

VR goggle and phone storage

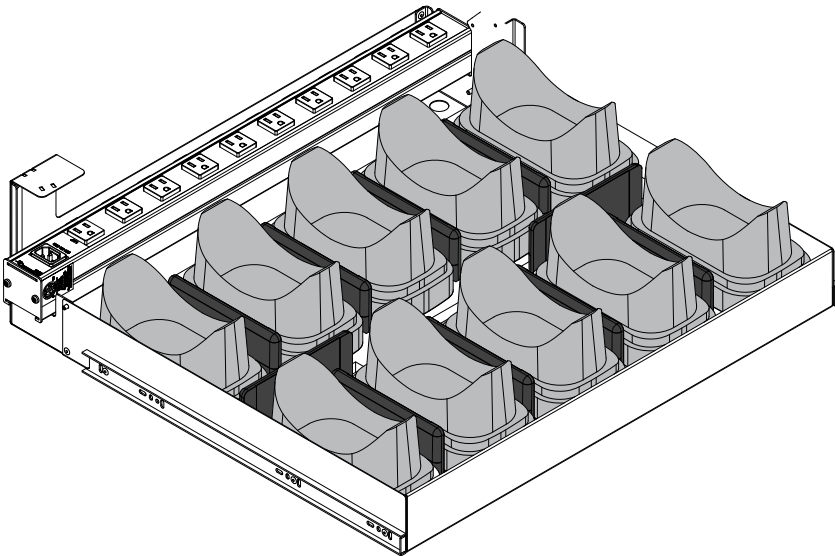

Note: The cart is designed with a safety mechanism that allows only one drawer to be pulled out at a time.
Max weight per drawer: 25 lb [11.35 kg]

5" Balloon Wheel

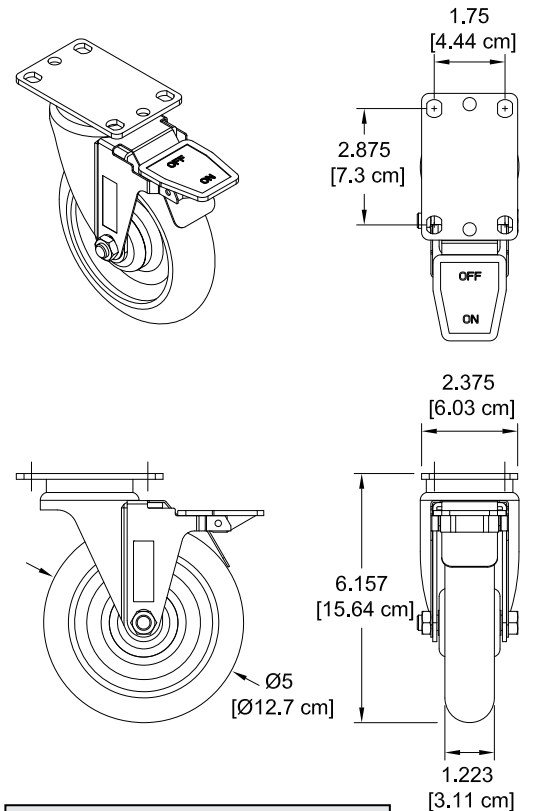

Note: (2) locking, and (2) non-locking casters are included on each unit.

Device-side locking doors
(shown with goggles and phones installed)

Note: Do not place items weighing more than 50 lb [22.7 kg] on the top surface. Please remove or secure items before moving cart.

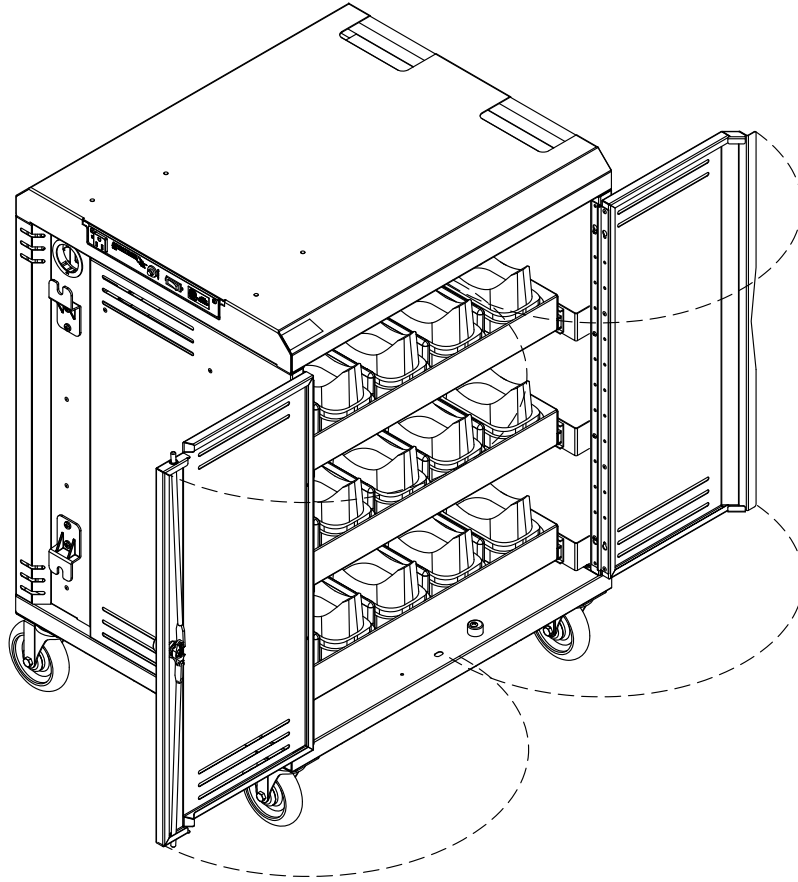

Power-side locking access panel

Device-side doors

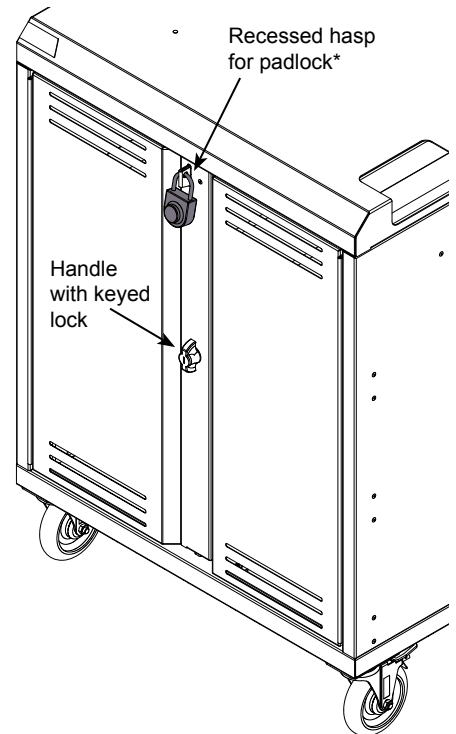
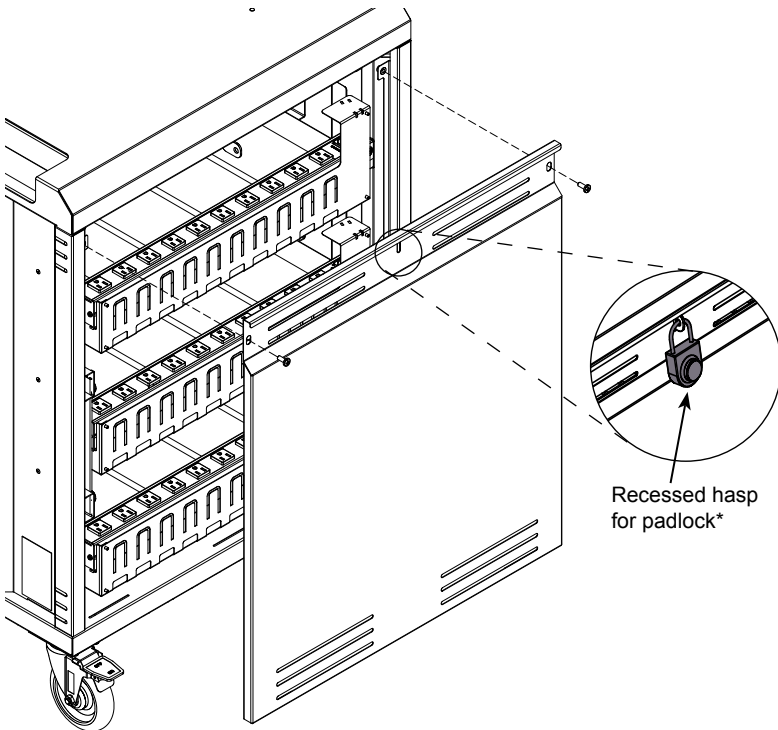

Electrical comparison		
PowerProdigy™ Timer	Power Switch Timer	
✓	✓	External auxiliary outlet
✓	✓	Internal auxiliary outlet
✓	✓	External on/off switch
✓		Load-sensing technology
✓		4 bank
✓		For most power adapters up to 65W
	✓	For most power adapters up to 45W
✓		LED lights indicate charging status
✓	✓	ETL certified to 60950-1

**Total maximum wattage will be affected by actual charge adapter wattage and number of charge adapters per cart. See more wattage / adapter recommendations below.*

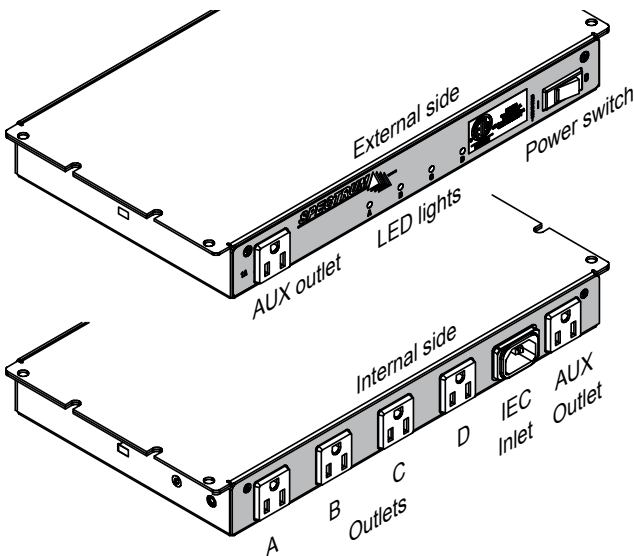

PowerProdigy™ Timer (Q)

Use with higher amp-draw devices. The PowerProdigy™ Timer can be used with most power adapters up to 65W.

- Smart charging senses current and distributes power to the power units requiring it most
- Four green LED lights indicate charging activity status of each power unit
- Four timed power unit-dedicated outlets (labeled A, B, C, D) controlled by logic board
- Two auxiliary outlets (1 external, 1 internal)
- ETL recognized (certified to 60950-1)

Input:	125V~/12A, 60Hz
Breaker:	15A, 250 VAC
Cycling interval:	15 minutes
Cycling outlets:	4 timed (A, B, C, D) up to 10A
Auxiliary outlets:	1A each (controlled by main power switch)
Power Cord:	IEC quick-release (replaceable) 8' nominal, 14 AWG, 3-wire
Power switch:	15A (externally accessible)

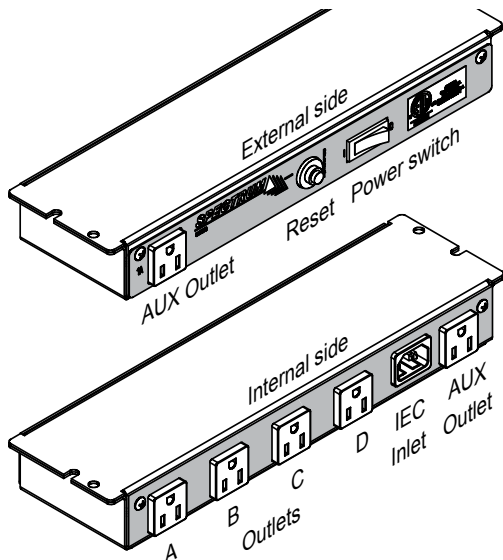

Power Switch (R)

The Power Switch provides continuous power to all power units. Use with lower amp-draw devices. The Power Switch can be used with most power adapters up to 45W.

- Four continuous power-unit dedicated outlets (labeled A, B, C, D)
- Two auxiliary outlets (1 external, 1 internal)
- ETL recognized (certified to 60950-1)

Input:	125V~/12A, 60Hz
Breaker:	15A, 250 VAC
Outlets:	4 timed (A, B, C, D) up to 10A
Auxiliary outlets:	1A each (controlled by main power switch)
Power Cord:	IEC quick-release (replaceable) 8' nominal, 14 AWG, 3-wire
Power switch:	15A (externally accessible)

VR30 Cart

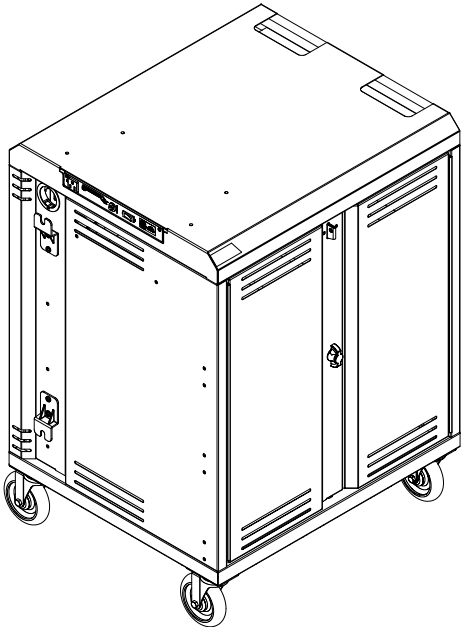

Power-side panel with hasp

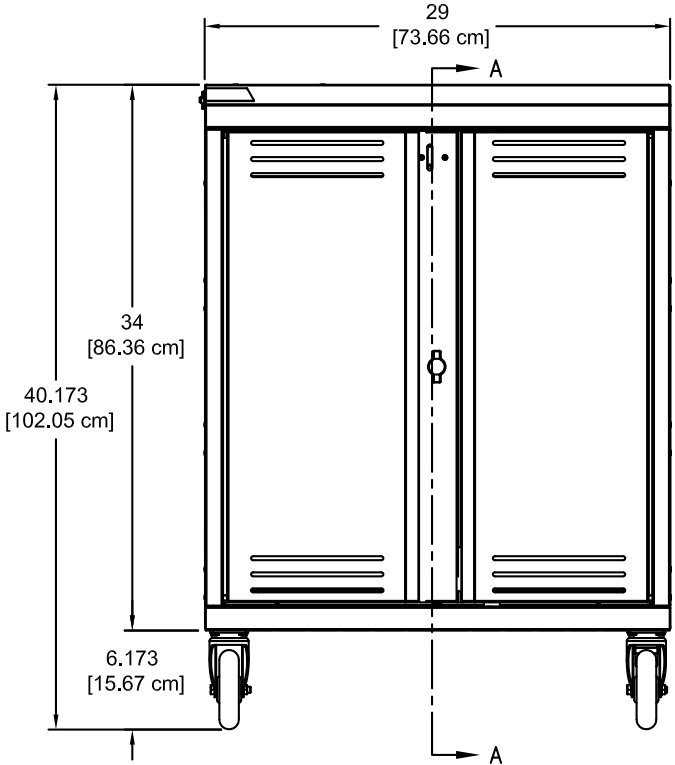
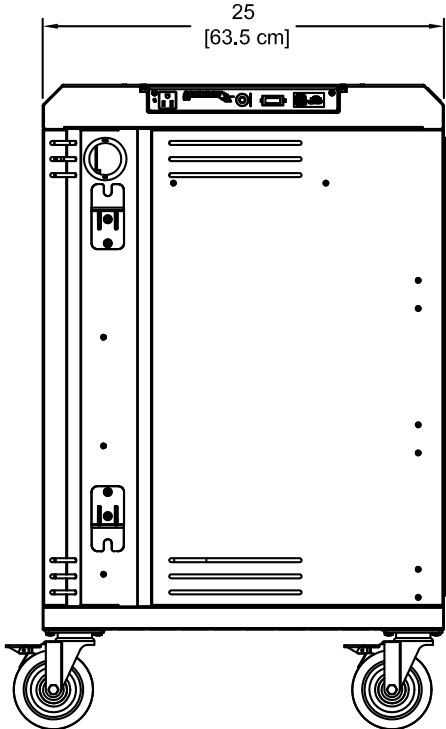
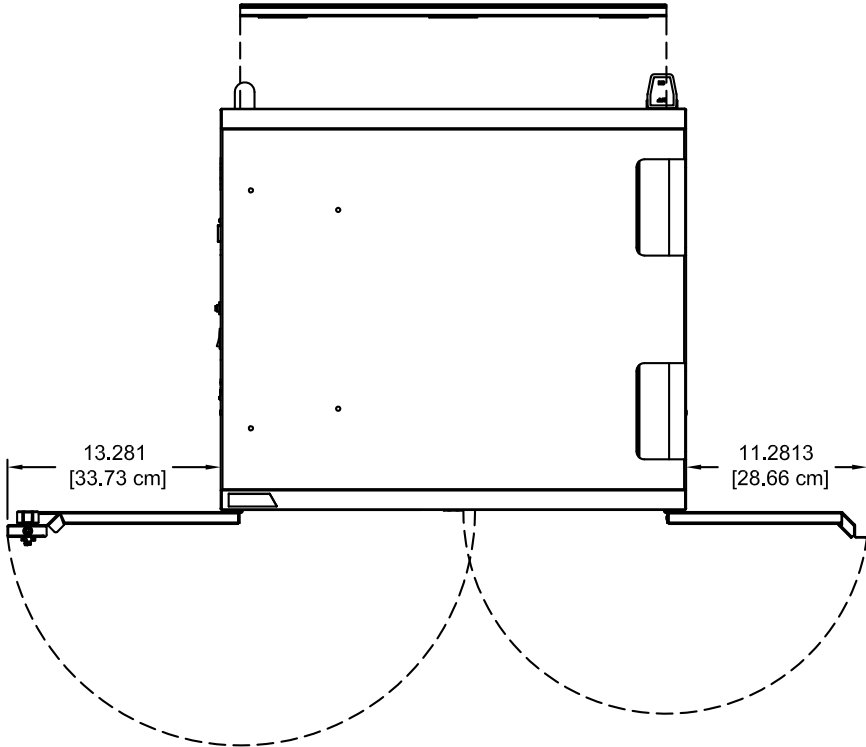

VR30
Section view A-A

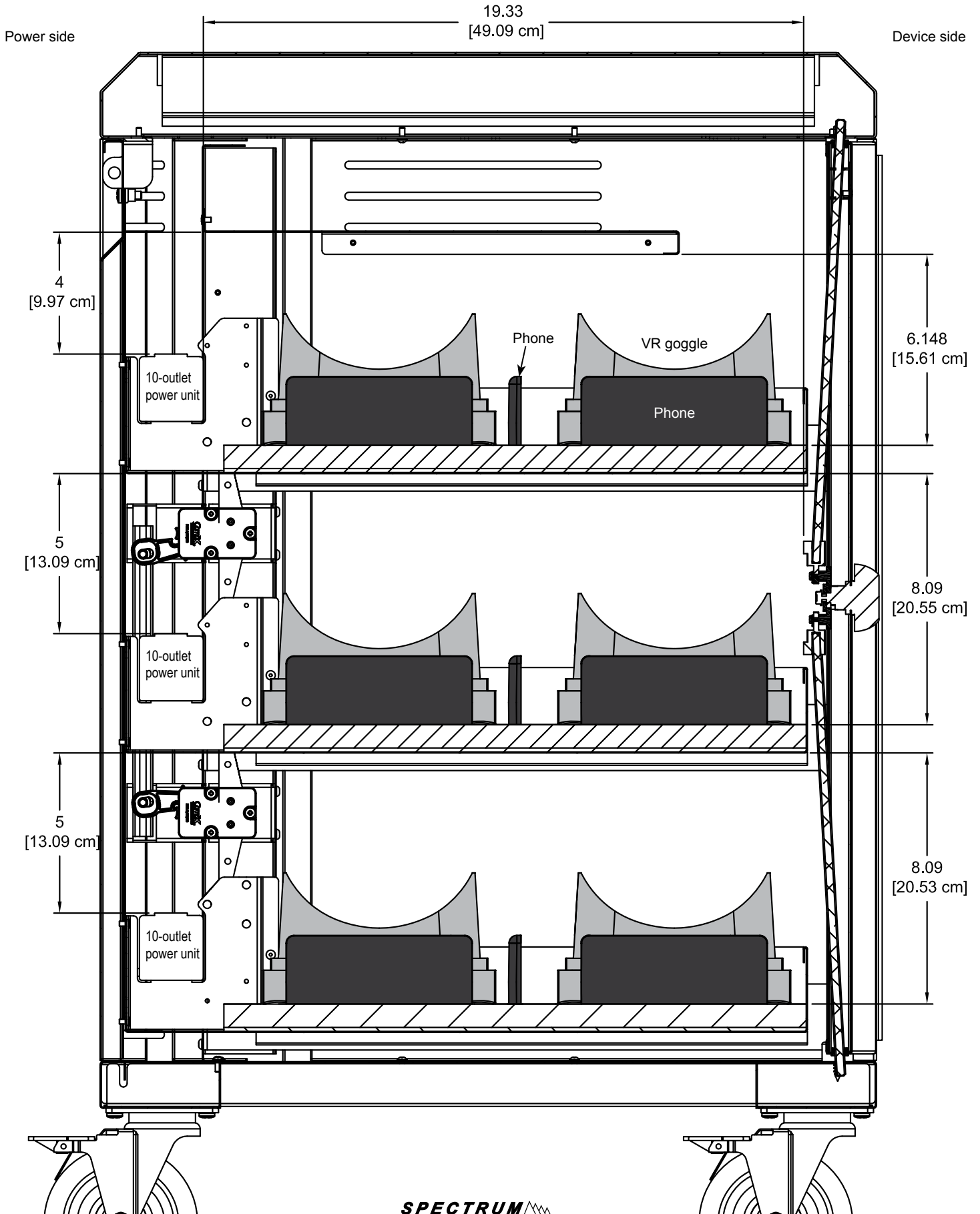

VR30
Device side view
(shown with doors open)

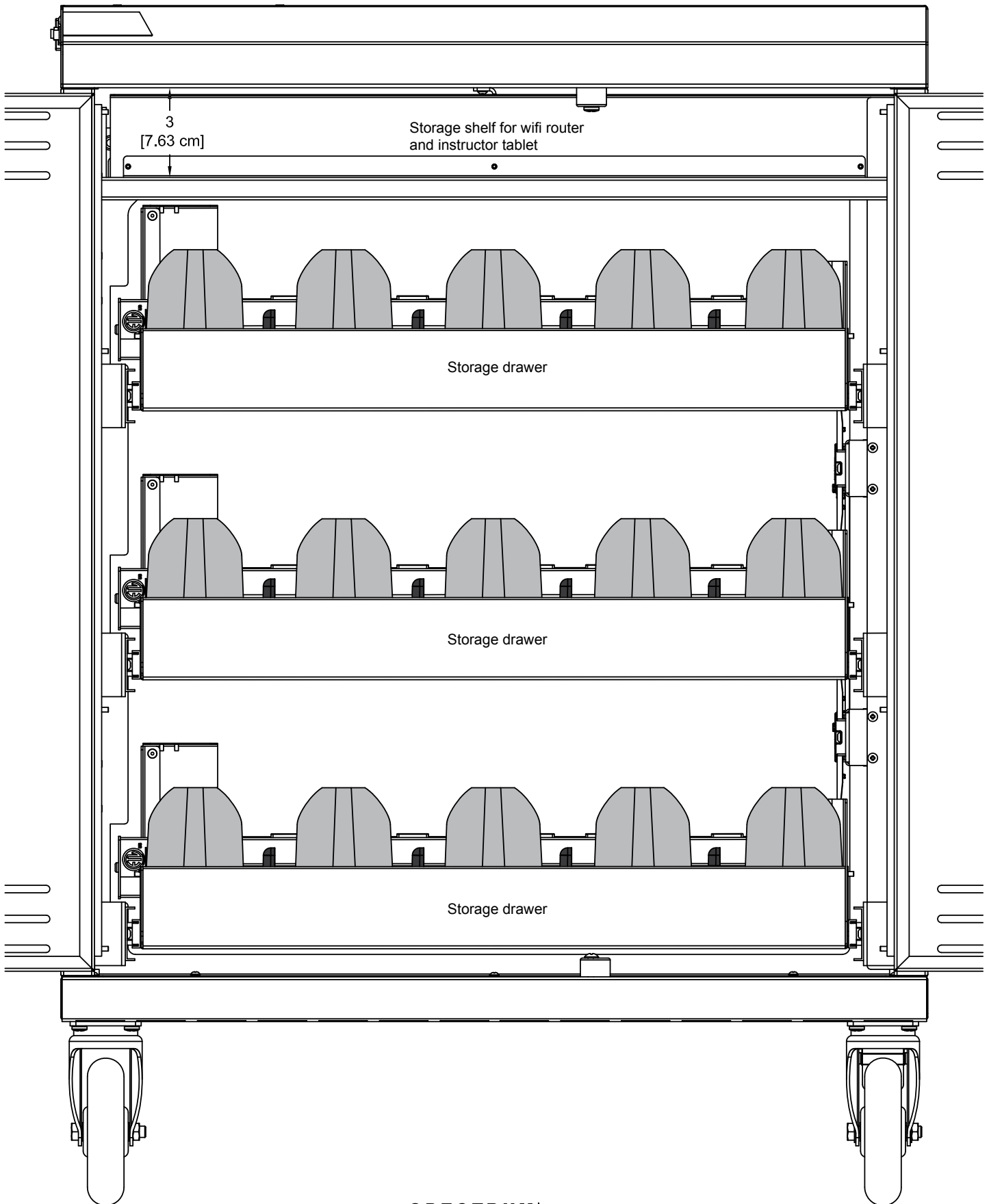

VR30
Power side wiring diagram
(locking panel removed)

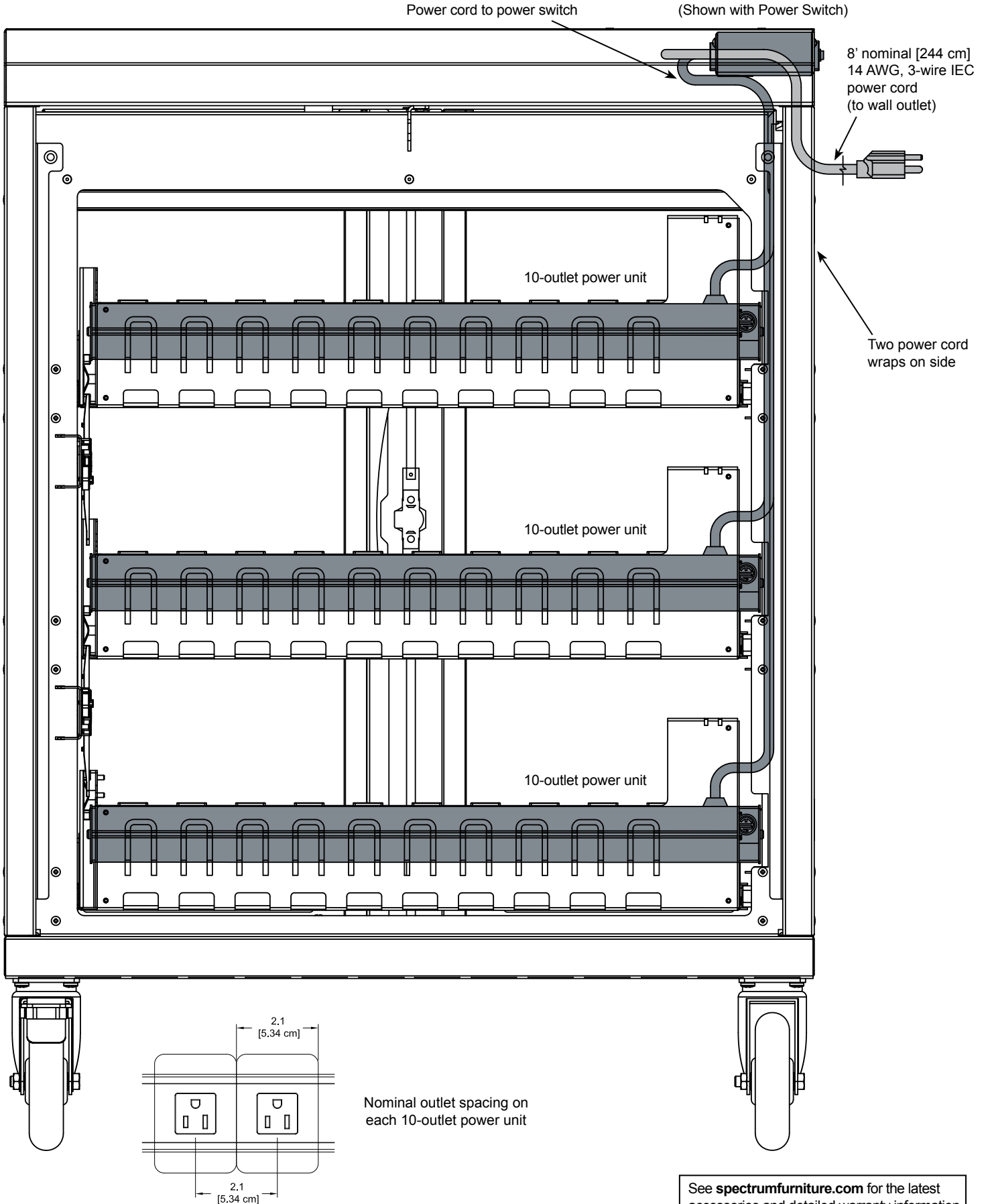

Accessories

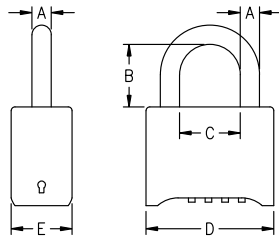

A	.3125" [7.9 mm]
B	1" [25.4 mm]
C	.983" [25 mm]
D	2.07" [52.5 mm]
E	.987" [25.1 mm]

Reprogrammable 4-digit Combination Lock - 95536

- Set your own 4-digit personalized combination (up to 10,000 options)
- 5/16" hardened steel shackle for cut-resistance
- Black powdercoated die-cast body for durability
- Change key included
- Unit weight: .55 lb [.25 kg]

Touchboards

205 Westwood Ave, Long Branch, NJ 07740

Phone: 866-94 BOARDS (26273) / (732)-222-1511

Fax: (732)-222-7088 | E-mail: sales@touchboards.com

Warranty

WE WILL MAKE IT RIGHT FOR YOU!

Spectrum is committed to provide complete customer satisfaction. Each of our products is manufactured from the best materials available and each product is stringently monitored throughout the production process through our P.A.C.E. program (Product Assurance to meet Customer Expectations).

We expressly warrant that Spectrum products will be of good quality and workmanship and free from defect for the period set out in the warranty table below from the date of delivery. This warranty shall not apply to defects or damage resulting from misuse, abuse, neglect, improper care, modification or repair not authorized by Spectrum, or any other cause outside the control of Spectrum. Spectrum will, at its sole option, either repair or replace the defective product.

This warranty is exclusive; no other warranty, written or oral, is expressed or implied. This warranty is given by Spectrum to Buyer and to no other person or legal entity. No Spectrum dealer, distributor, agent or employee is authorized to make any modification or addition to this warranty.

NOTWITHSTANDING ANYTHING TO THE CONTRARY, SPECTRUM WILL NOT UNDER ANY CIRCUMSTANCES BE LIABLE FOR INDIRECT OR LIQUIDATED DAMAGES, INCLUDING CONSEQUENTIAL, INCIDENTAL AND SPECIAL DAMAGES. IN NO EVENT SHALL SPECTRUM'S LIABILITY, WHETHER UNDER CONTRACT OR WARRANTY, IN TORT OR OTHERWISE, EXCEED THE PURCHASE PRICE RECEIVED BY SPECTRUM FOR THE PRODUCT AT ISSUE AND "RECALL ACTION" EXPENSES. SPECTRUM SHALL NOT BE SUBJECT TO ANY OTHER OBLIGATIONS OR LIABILITIES, WHETHER ARISING OUT OF BREACH OF CONTRACT, WARRANTY, TORT (INCLUDING NEGLIGENCE AND STRICT LIABILITY) OR OTHER THEORIES OF LAW, WITH RESPECT TO PRODUCTS SOLD OR SERVICES RENDERED BY SPECTRUM, OR ANY UNDERTAKINGS, ACTS OR OMISSIONS RELATING THERETO.

Our Customer Service Department is ready to provide immediate attention to any questions, comments or concerns. They are available to answer your calls Monday through Friday from 7 am to 5 pm CST. In addition your product comments or concerns are welcome via e-mail at: spectrum@spectrumfurniture.com.

Warranty Table

Item	Warranty Period effective 1/1/2015
Adjustable Crank / Electric Desk Legs	• 1 Year
Flat Panel Desk Gas Cylinders	
Chairs <ul style="list-style-type: none"> • Adjustable Height Chair Parts – including frames, gas cylinders, wood and plastic parts, control handles, casters • Adjustable Height Chair Upholstery • In-Stock Upholstery • Graded-In Fabrics and Customer Owned Material 	<ul style="list-style-type: none"> • 7 Years • 2 Years • 2 Years • No Warranty
Height Adjustable Columns and Lifts	• 1 Year
General Use Casters	
Electrical (including timers and LINAK actuators)	• 2 Years
Keyboard / Mouse Trays	• 1 Year
Flat Panel Monitor Arms <ul style="list-style-type: none"> • Flat Panel Monitor Arm – General Parts • Flat Panel Monitor Arm – Gas Cylinders 	<ul style="list-style-type: none"> • 5 Years • 2 Years
Desks and Lecterns <ul style="list-style-type: none"> • Computer Desk Chassis • Cart Chassis • Lectern Chassis 	• 10 Years

