

Technical Specifications

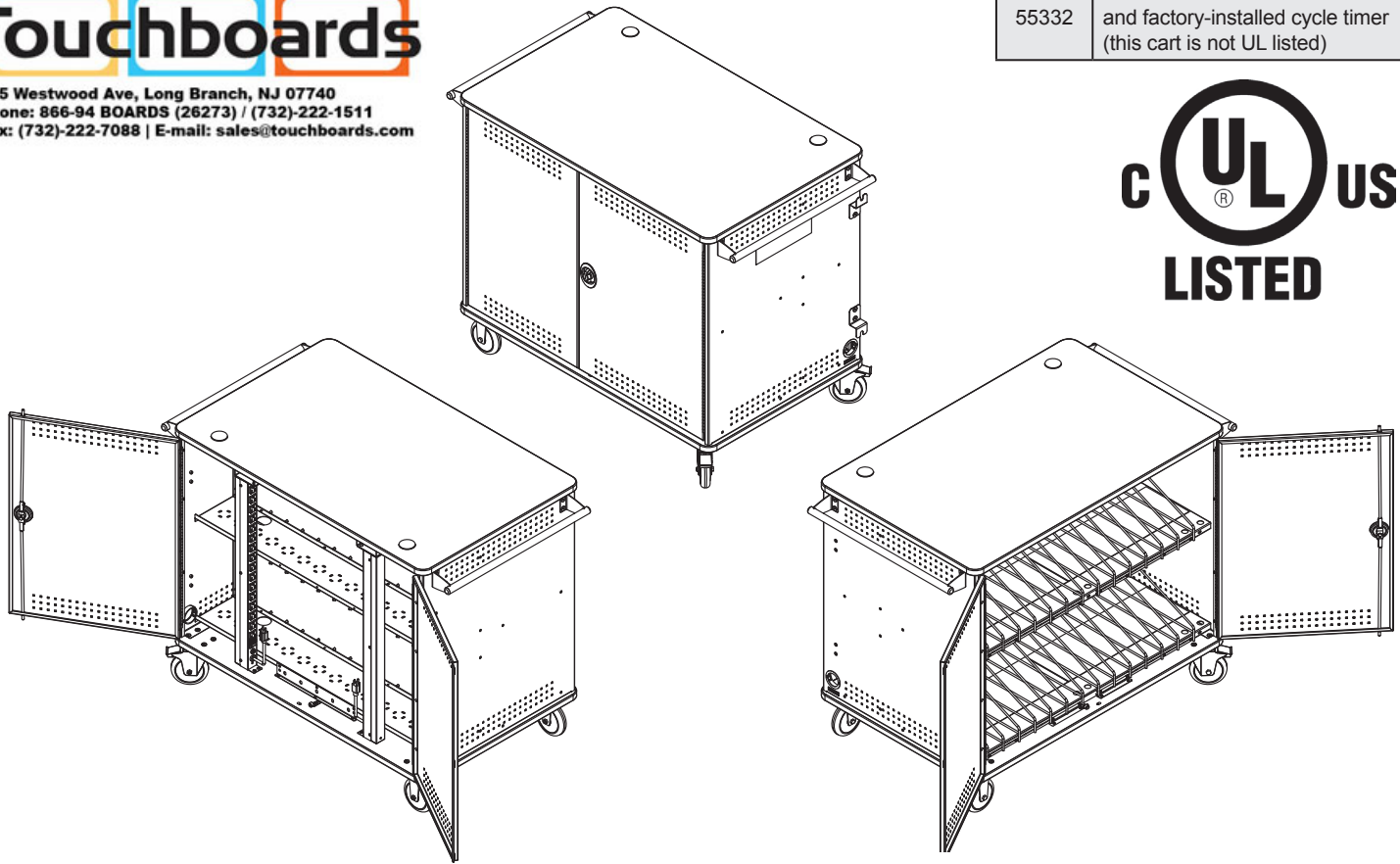

205 Westwood Ave, Long Branch, NJ 07740
Phone: 866-94 BOARDS (26273) / (732)-222-1511
Fax: (732)-222-7088 | E-mail: sales@touchboards.com

55321	vLT-30 with 5" Balloon Wheels
55332	vLT-30 with 5" Balloon Wheels and factory-installed cycle timer (this cart is not UL listed)



The vLT line represents quality and excellence in a laptop cart without overstressing your budget. The vLT-30 cart accommodates 30 full-size laptops and combines security with mobility to provide a resourceful laptop cart for the classroom environment. Power is supplied to every bay, but electrical outlets are stored out of sight and out of reach for day-to-day operation. Spectrum has used dedicated attention to customer needs, extensive knowledge of laptop carts, and superior design expertise to make the best valued cart on the market today, the vLT. And with the vLT, your laptop storage/recharging requirements can be met without breaking the bank!

Features and Benefits

- Storage capacity of up to 30 laptops
- Ample clearance is provided for easy removal/insertion of laptops
- Easy access to electrical power
- Scratch and impact-resistant 1 1/16" high-pressure laminate worksurface
- Double-bolt, keyed locking doors provide security and easy-access
- Four 5" locking balloon wheels roll easily and quietly on uneven surfaces
- Worksurface and bottom panel grommets keep wires and cords manageable
- Padded shelves and coated dividers protect laptops from damage
- Doors and panels are ventilated to keep laptops and chargers cool
- Two standard handles provide control and mobility
- Cord management system keeps charge cords organized at the back of each storage slot (Velcro® tie-downs included)
- External cord management brackets keep power cords together
- Electrical system consists of UL listed components
- Two 16-outlet power units with 15-amp breaker and reset button
- Warranted to be free of all defects in materials and workmanship for 10 years, electrical system 1 year

Base Options
BW - 4 swivel wheels SR - 2 rigid, 2 swivel wheels

Options & Accessories
Page 8

Color Options

Standard laminate / color combinations

Wild Cherry / Black
(CHB)



Indigo Organix / Black
(IB)



Standard color combination refers to the quickest deliverable product color combination. Custom laminates and color combinations are available-additional lead-times and up-charges may apply. Call 1-800-235-1262 for further information.

Construction

- The worksurface and base panel is constructed from 1 $\frac{1}{16}$ " NAUF (No Added Urea Formaldehyde) composite board with .030 high-pressure laminate on one face, and a balancing phenolic backer on the opposing face
- 16-gauge side panels, and front door
- 20-gauge shelves
- All metal components are finished with a scratch-resistant powder coat epoxy
- Worksurface edges are covered with 3mm vinyl
- Each vLT-30 Laptop Cart is factory-assembled, packaged, and shipped on its own skid (*handle, and cord wrap brackets to be installed by customer*)

Specifications

Laptop capacity	30 units
Storage slots	30 slots: 2 $\frac{3}{4}$ "W x 16 $\frac{3}{16}$ "D x 14 $\frac{3}{4}$ "H
Electrical	The vLT-30 has two 16-outlet (125V) power units, each containing a 15-amp breaker, on/off switch and a 12' nominal 14 AWG, 3-wire power cord. Outlets are accessible from the back of the unit. A separate wall circuit is recommended for each power strip. UL listed components.
5" Balloon Wheels	weight capacity 325 lbs each
Cycle Timer	12-amp, 120 volt, 60Hz with a 15-240 minute timer, 15', 14 AWG power cord, UL listed components
Shipping weight (nominal)	339 lbs - 55321 323 lbs - 55332

Meets or exceeds applicable ANSI-BIFMA test standards

Specifications subject to change without notice

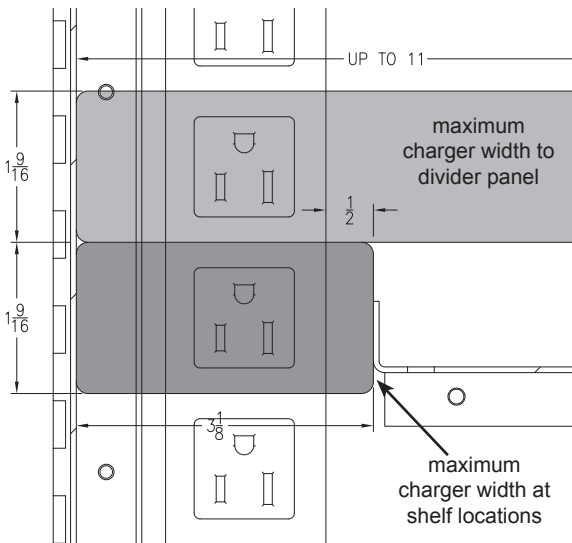

outlet spacing on each 16-outlet power unit

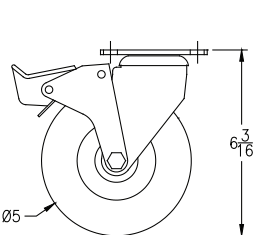

5" balloon wheels

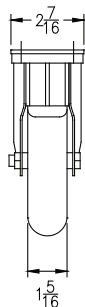

Caution
This cart is intended for use only with the maximum weights indicated. Use with appliances heavier than the maximum weights indicated may result in instability causing possible injury.

Caution
Maximum load not to exceed 40 lbs per rear shelf

Caution
Maximum load not to exceed 322 lbs on worksurface

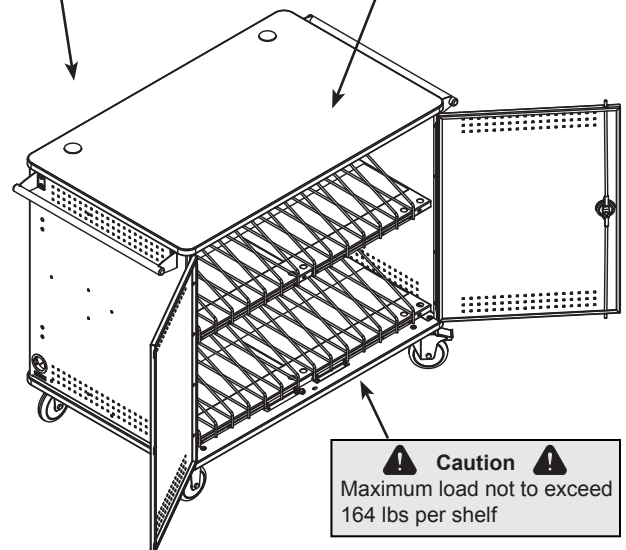

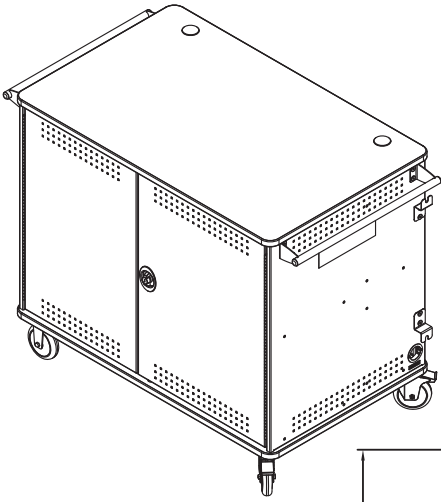

vLT-30 Laptop Cart

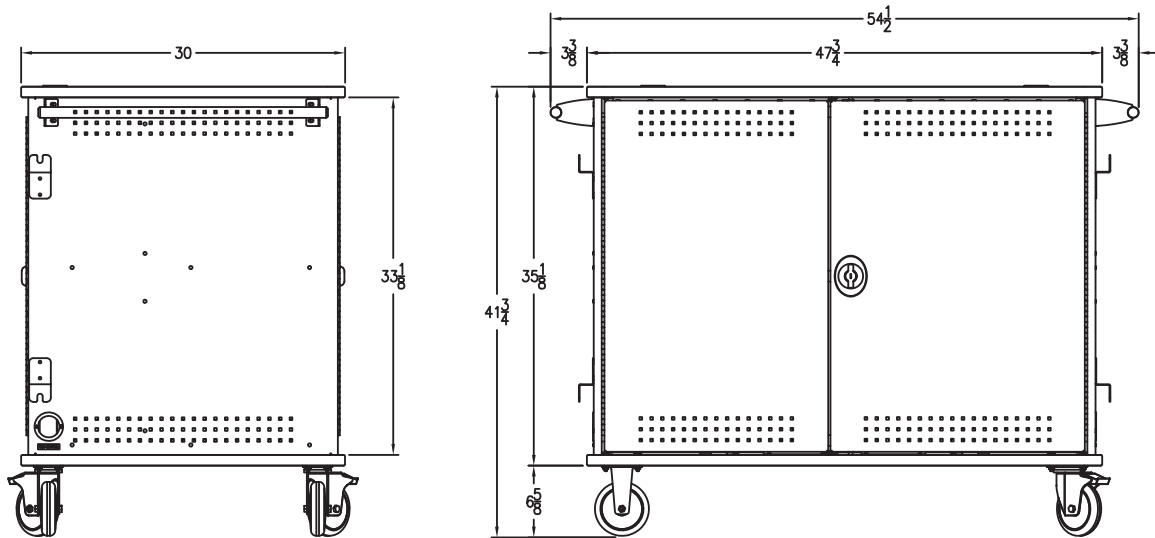
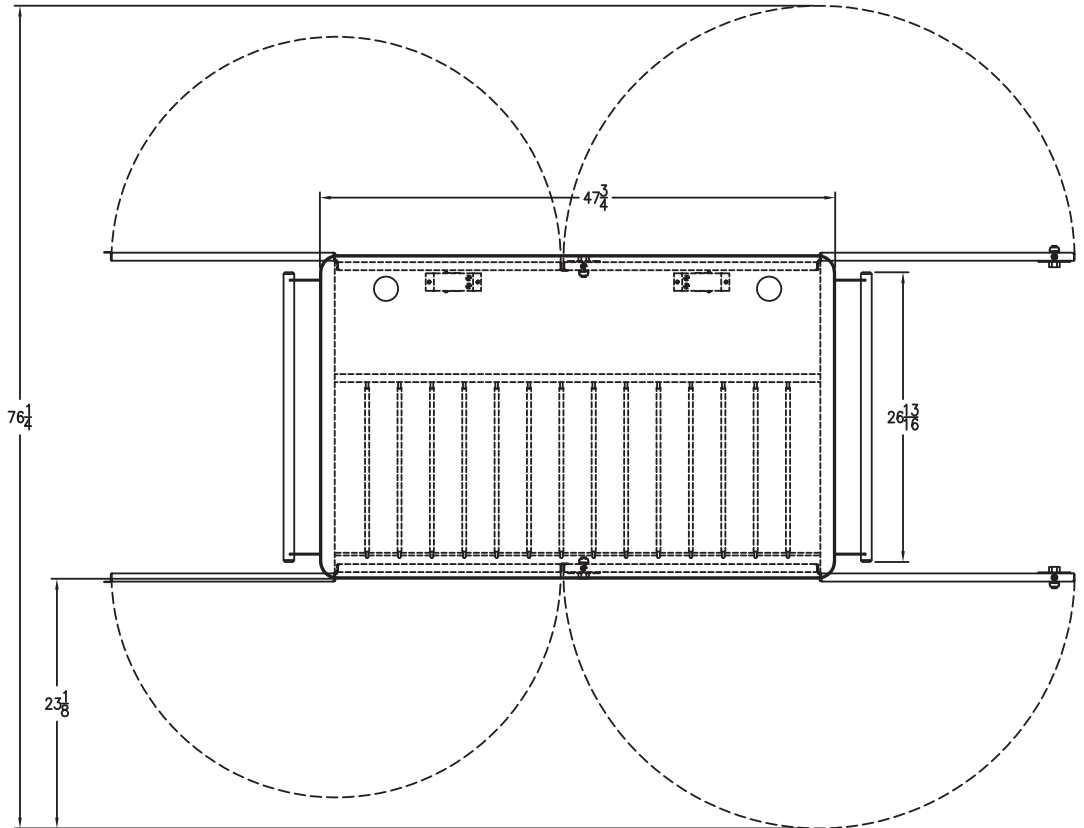

vLT-30 cord management
student-side view
(shown without doors)

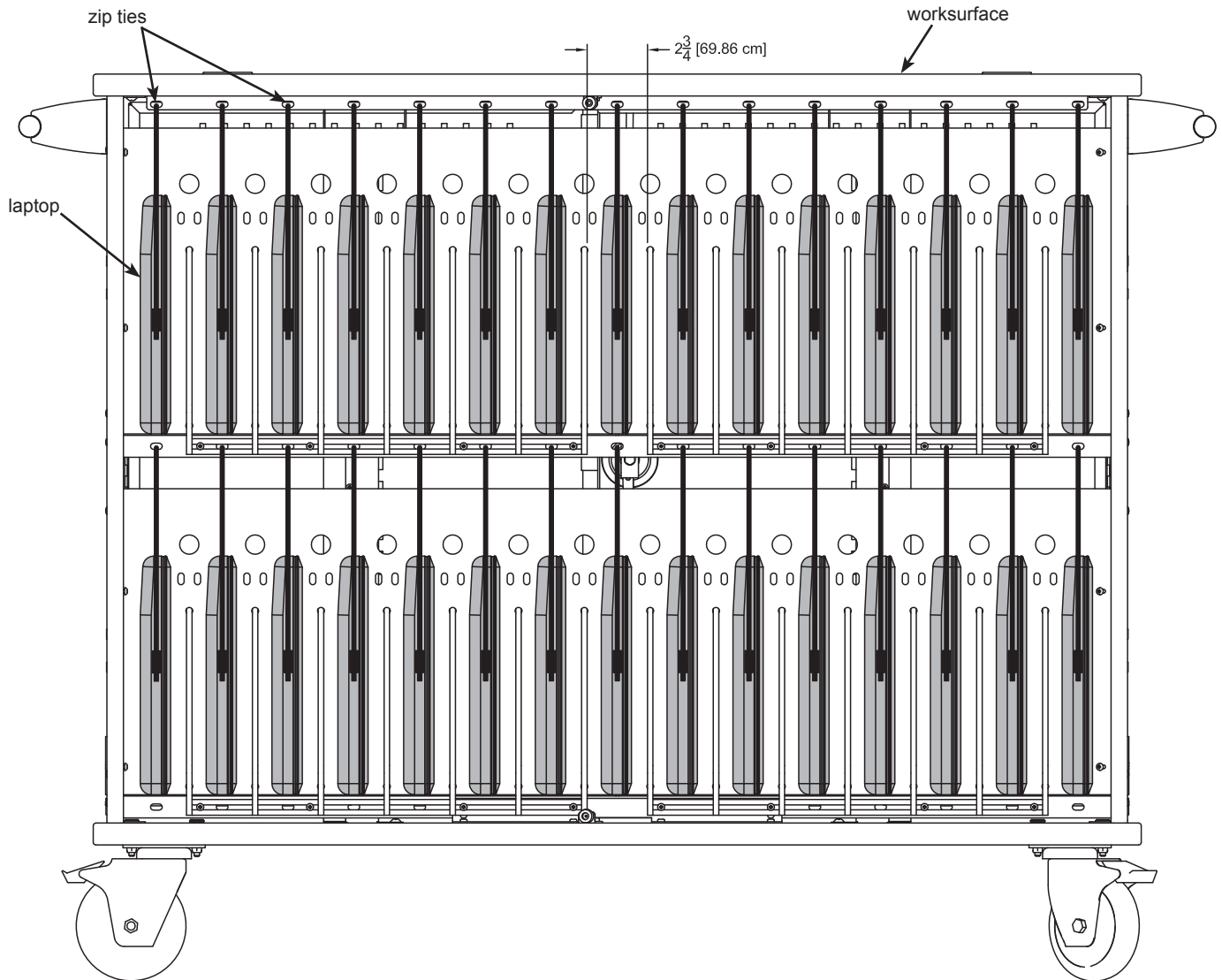

Touchboards

205 Westwood Ave, Long Branch, NJ 07740
Phone: 866-94 BOARDS (26273) / (732)-222-1511
Fax: (732)-222-7088 | E-mail: sales@touchboards.com

vLT-30 section view

power-side

student-side

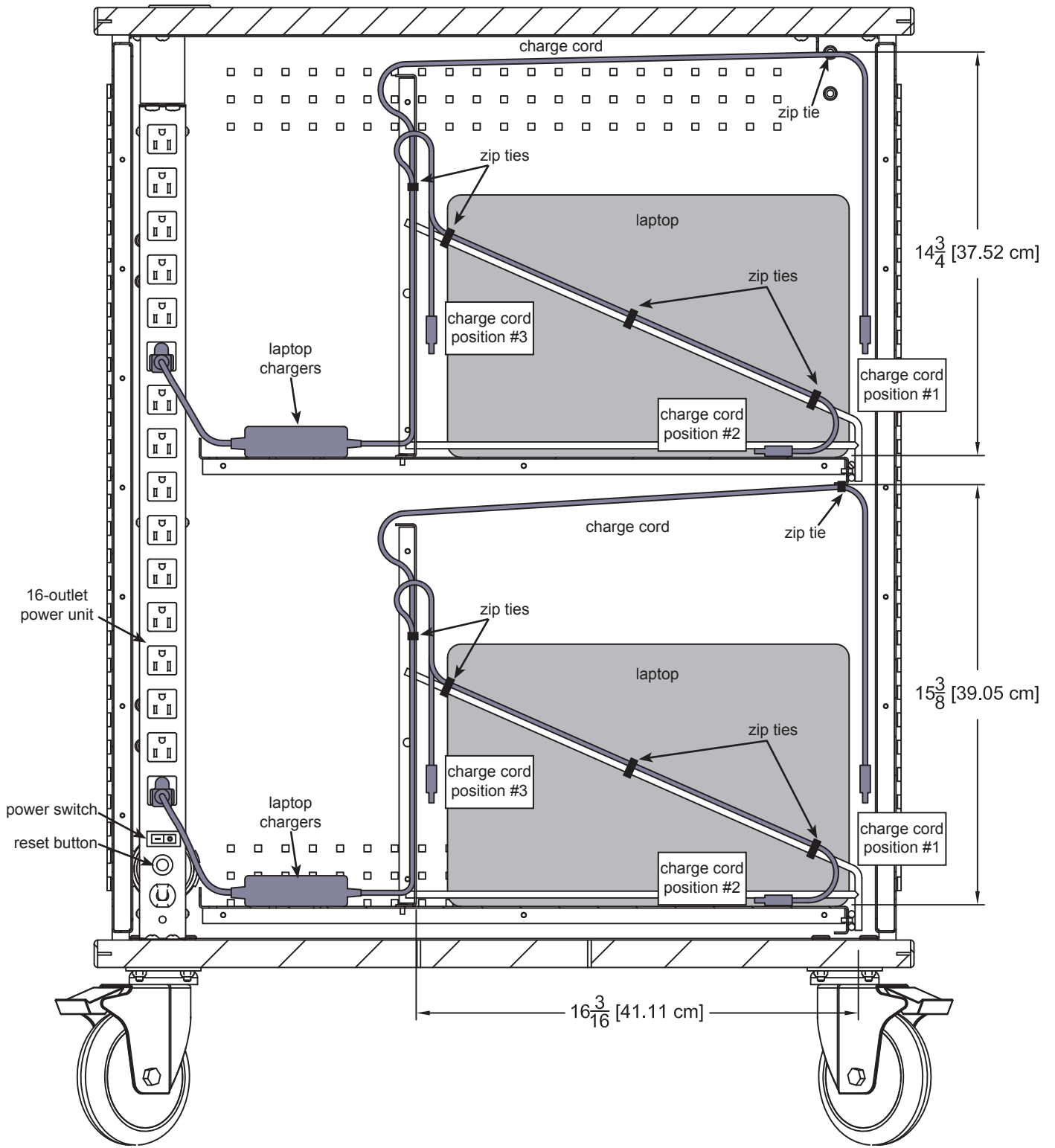

top view of cord management tray

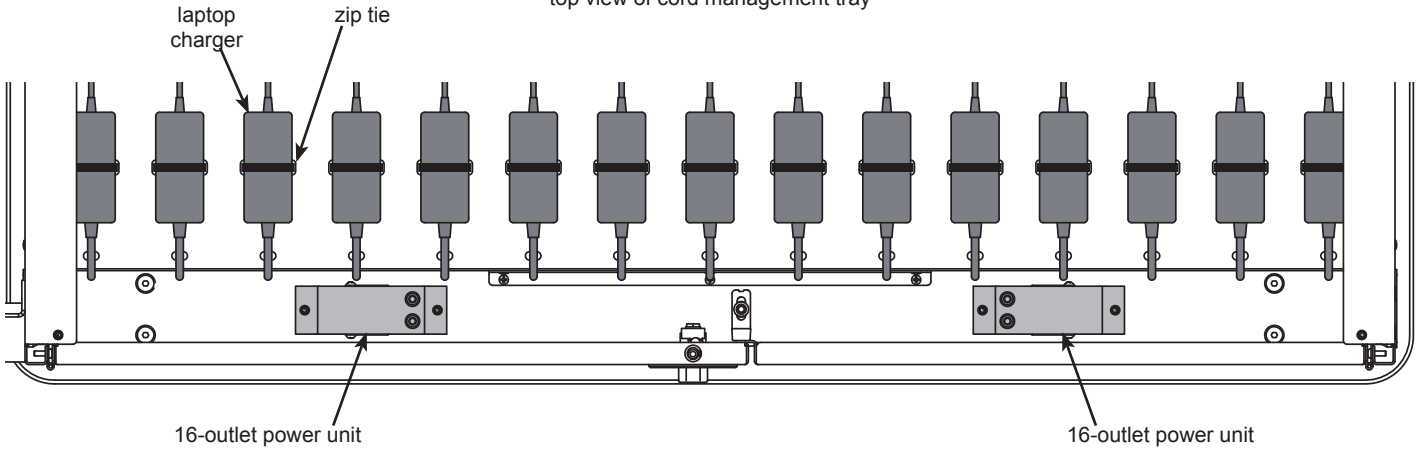

CAUTION

The vLT-30 Laptop Cart features two separate 16-outlet charging circuits on separate cords. Some computers may draw more than ½ amp when fully discharged. If that is the case, plugging the two power cords into separate 15-amp electrical outlets will prevent an electrical overload which may trip a circuit breaker. Please consult the owners manual of your specific laptop computer for further information.

power-side view (shown with doors removed)

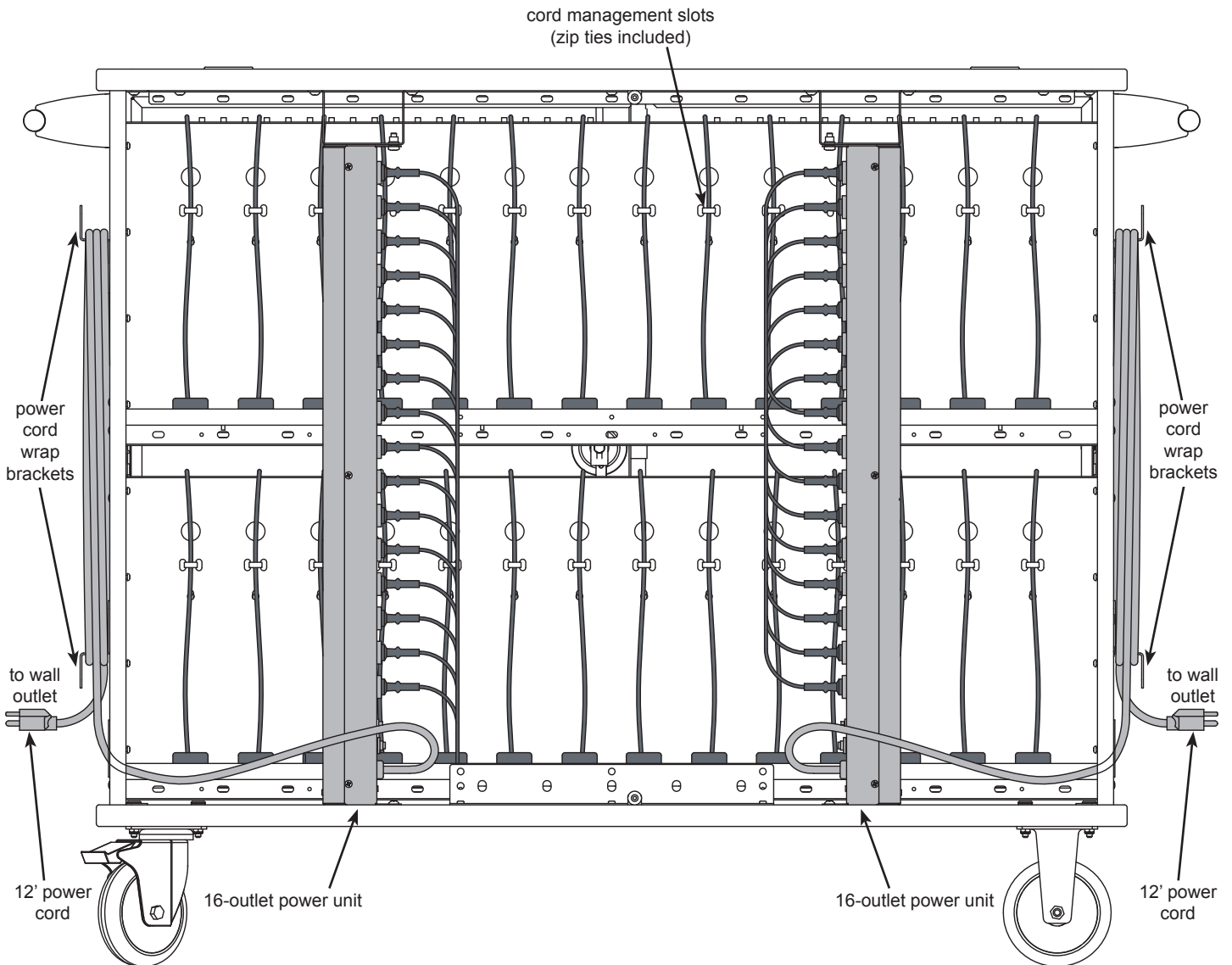

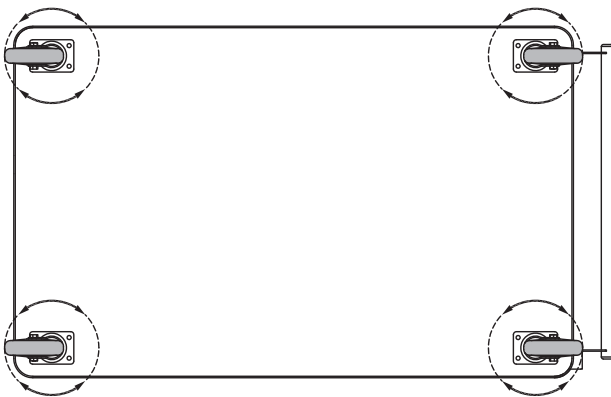
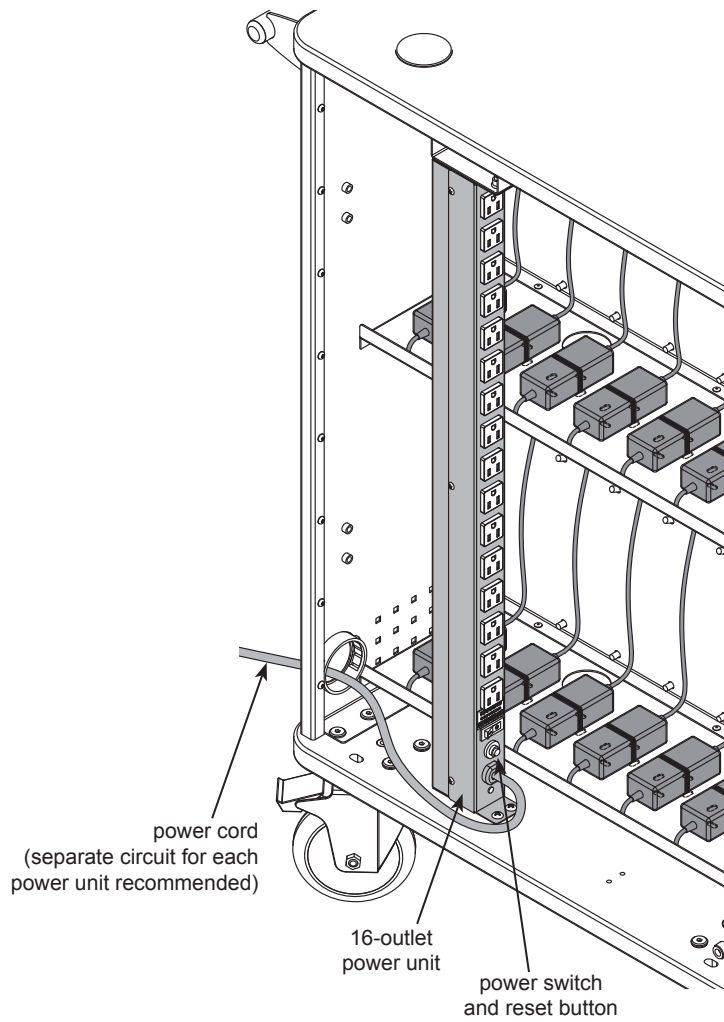

BW
5" Balloon Wheels (4 swivel)
Provides more maneuverability in tight spaces, but less control when mobile

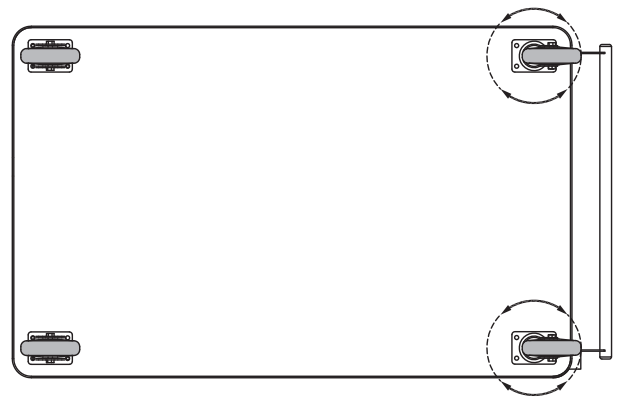

SR
5" Balloon Wheels (2 swivel, 2 rigid)
Provides more control when mobile, but less maneuverability in tight spaces

vLT-30 power-side view with cycle timer
(shown without laptop chargers for clarity)

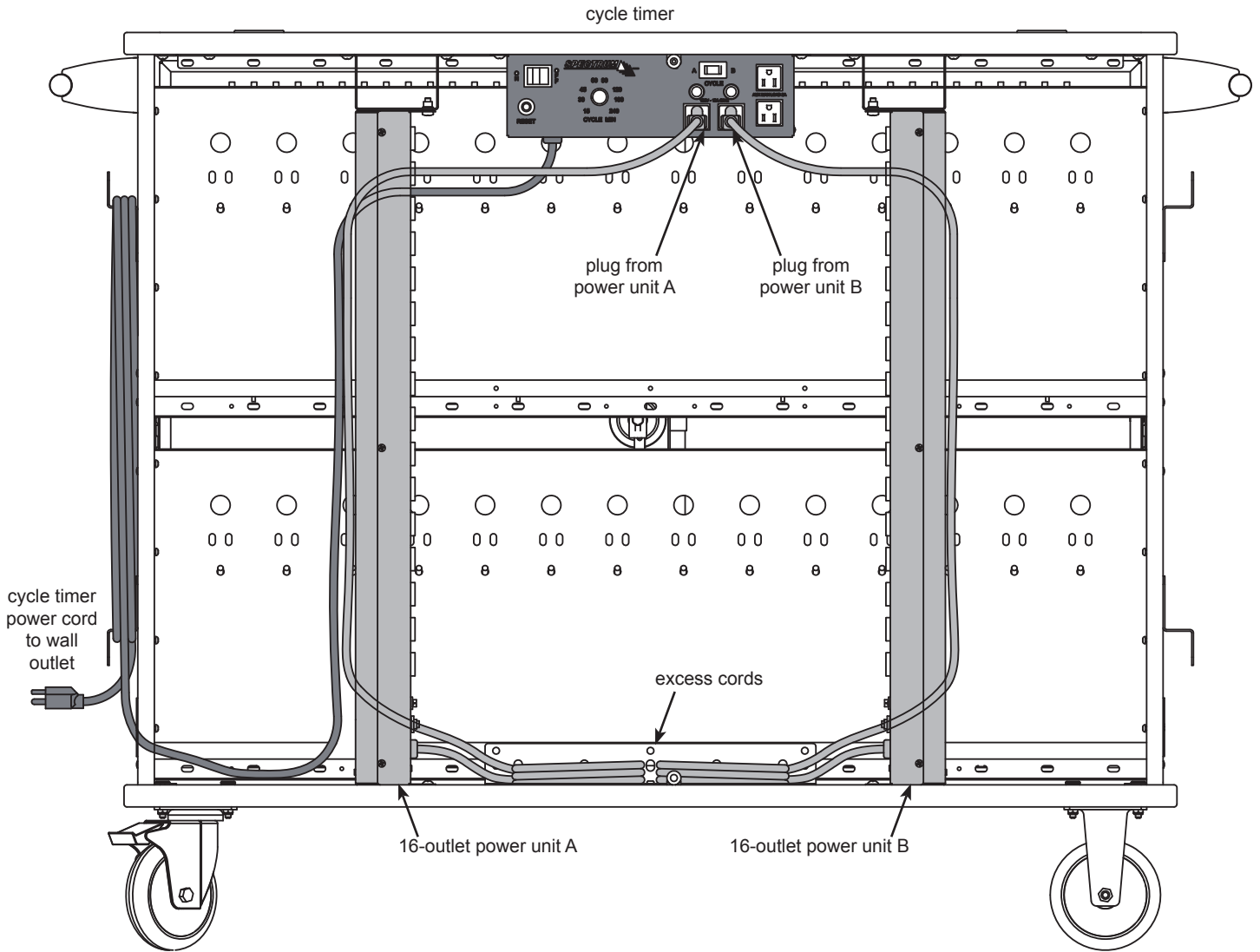

Options

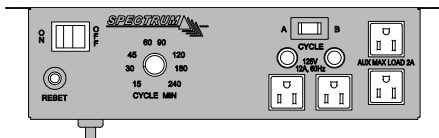

**Value cycle timer
with 15' cord**
(See above for wiring diagram)
99035



Velcro® strap kit
(16) ¾" x 12", and (32) ¾" x 5"
Velcro® straps
95004

Optional Cycle Timer

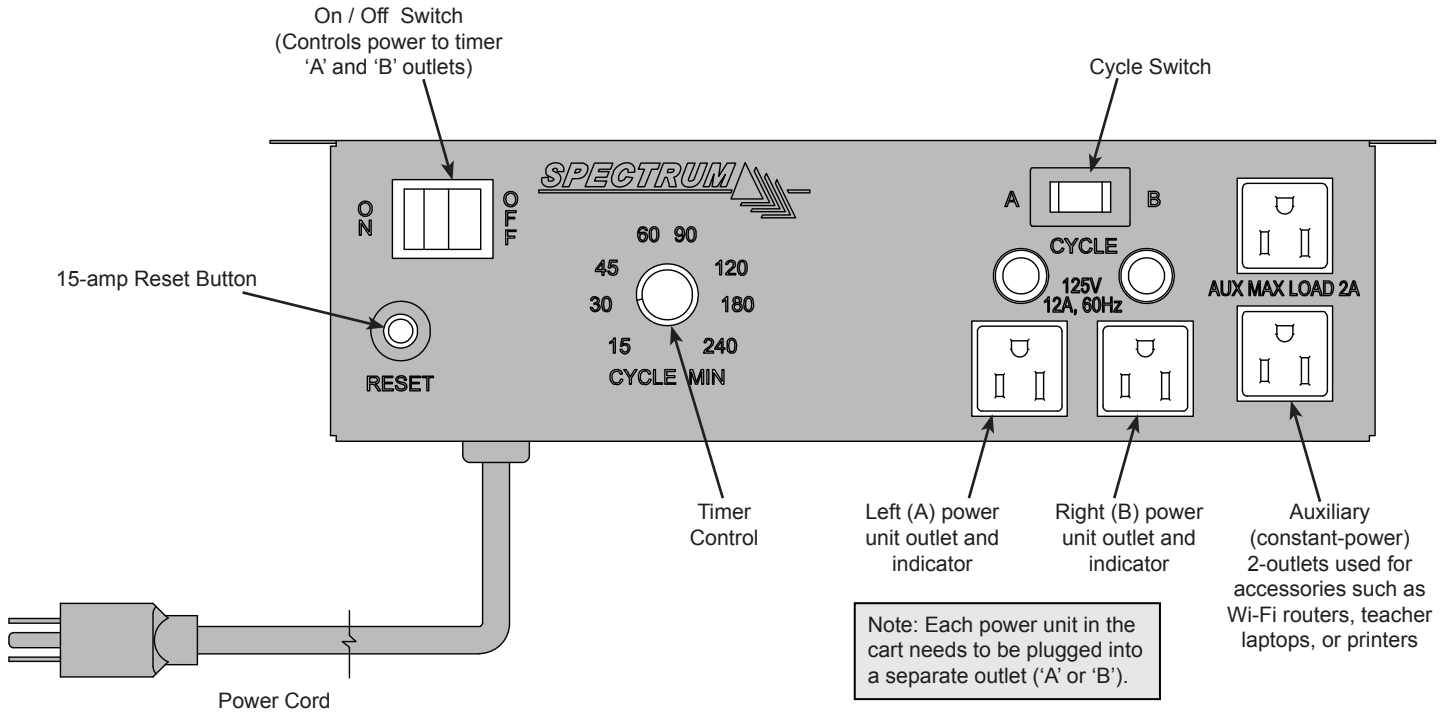

Using Timer

The timer prevents overload by alternating power between both power units in the cart, providing charging to multiple laptops or devices during the day. The power units plug into the outlets labeled 'A' or 'B'.

The timer control can be adjusted between 15-240 minutes. This is the number of minutes a power unit will be "hot" before the timer switches to the other power unit. 15 minutes can be used as the default setting, but the time setting will depend on the laptop size, battery capacity, frequency of laptop use, and the time available for charging between uses. Lower minute settings should be used if the laptops are being used more frequently.

- To cycle charge both 'A' and 'B' sides, keep the cycle switch in the middle 'Cycle' position, then set the timer control to the desired cycling increment. After the side 'A' time expires, the timer will activate side "B" for the same period of time and will continue to cycle until the On/Off switch is set to the "OFF" position.
- To manually-override the timer function, and charge the 'A' or 'B' side only, switch the cycle switch from the middle to the 'A' or 'B' position.

Specifications

- 12-amp, 120 volt, 60Hz
- 15-240 minute timer
- 15', 14 AWG power cord

⚠ CAUTION ⚠

- Do not use the auxiliary outlets to charge multiple laptops or devices (use the 'A' and 'B' outlets only.) Auxiliary outlets are for peripheral use only.
- Switch the timer power switch OFF before unplugging or plugging-in the main power unit plugs
- Total equipment load not to exceed 12-amps per power unit.
- For indoor use only. Do not install or store the unit where it will be exposed to weather. Keep dry.
- For added safety, plug the timer into a grounded three-prong receptacle controlled by a GFI (Ground Fault Interrupter) circuit breaker.

Warranty

WE WILL MAKE IT RIGHT FOR YOU!

Spectrum is committed to provide complete customer satisfaction. Each of our products is manufactured from the best materials available and each product is stringently monitored throughout the production process through our P.A.C.E. program (Product Assurance to meet Customer Expectations).

We expressly warrant that Spectrum products will be of good quality and workmanship and free from defect for the period set out in the warranty table below from the date of delivery. This warranty shall not apply to defects or damage resulting from misuse, abuse, neglect, improper care, modification or repair not authorized by Spectrum, or any other cause outside the control of Spectrum. Spectrum will, at its sole option, either repair or replace the defective product.

This warranty is exclusive; no other warranty, written or oral, is expressed or implied. This warranty is given by Spectrum to Buyer and to no other person or legal entity. No Spectrum dealer, distributor, agent or employee is authorized to make any modification or addition to this warranty.

NOTWITHSTANDING ANYTHING TO THE CONTRARY, SPECTRUM WILL NOT UNDER ANY CIRCUMSTANCES BE LIABLE FOR INDIRECT OR LIQUIDATED DAMAGES, INCLUDING CONSEQUENTIAL, INCIDENTAL AND SPECIAL DAMAGES. IN NO EVENT SHALL SPECTRUM'S LIABILITY, WHETHER UNDER CONTRACT OR WARRANTY, IN TORT OR OTHERWISE, EXCEED THE PURCHASE PRICE RECEIVED BY SPECTRUM FOR THE PRODUCT AT ISSUE AND "RECALL ACTION" EXPENSES. SPECTRUM SHALL NOT BE SUBJECT TO ANY OTHER OBLIGATIONS OR LIABILITIES, WHETHER ARISING OUT OF BREACH OF CONTRACT, WARRANTY, TORT (INCLUDING NEGLIGENCE AND STRICT LIABILITY) OR OTHER THEORIES OF LAW, WITH RESPECT TO PRODUCTS SOLD OR SERVICES RENDERED BY SPECTRUM, OR ANY UNDERTAKINGS, ACTS OR OMISSIONS RELATING THERETO.

Our Customer Service Department is ready to provide immediate attention to any questions, comments or concerns. They are available to answer your calls Monday through Friday from 7 am to 5 pm CST. In addition your product comments or concerns are welcome via e-mail at: spectrum@spectrumfurniture.com.

Warranty Table

Item	Warranty Period
<ul style="list-style-type: none"> Adjustable Crank/Electric Desk Legs Flat Panel Desk Gas Cylinders 	<ul style="list-style-type: none"> 1 Year
<ul style="list-style-type: none"> Adjustable Height Chair Parts – including frames, gas cylinders, wood and plastic parts, and control handles Adjustable Height Chair Parts Casters Adjustable Height Chair Upholstery In-Stock Upholstery Graded-In Fabrics and Customer Owned Material 	<ul style="list-style-type: none"> 7 Years 2 Years 2 Years No Warranty
<ul style="list-style-type: none"> Height Adjustable Columns and Lifts General Use Casters Electrical Keyboard/Mouse Trays 	<ul style="list-style-type: none"> 1 Year
<ul style="list-style-type: none"> Flat Panel Monitor Arm – General Parts Flat Panel Monitor Arm – Gas Cylinders 	<ul style="list-style-type: none"> 5 Years 2 Years
<ul style="list-style-type: none"> Computer Desk Chassis Cart Chassis Lectern Chassis 	<ul style="list-style-type: none"> 10 Years



205 Westwood Ave, Long Branch, NJ 07740
 Phone: 866-94 BOARDS (26273) / (732)-222-1511
 Fax: (732)-222-7088 | E-mail: sales@touchboards.com