

vLT-15 Laptop Cart w/ 8" Casters

55323SR vLT-15 Laptop Cart w/ 8" Casters

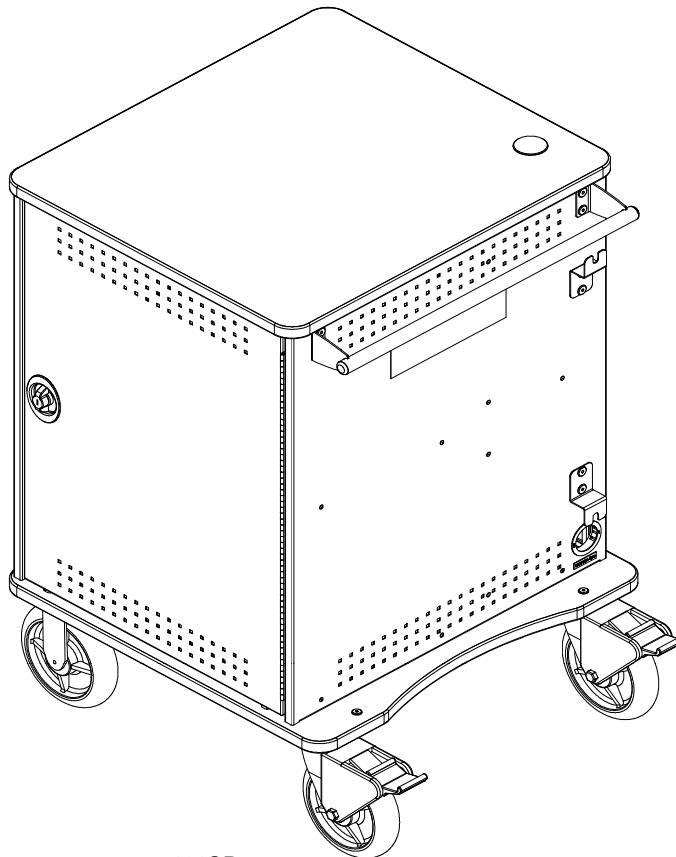

55323SR
vLT-15 w/ 8" casters

CAUTION:

Before using this product, read this manual and follow all safety and operating instructions.

IMPORTANT:

Before you begin, please make sure all parts and proper quantities are included. Any parts damaged during shipment must be reported within 15 days of receipt. To report information regarding damages or if you have any questions, please call 1-800-235-1262.

To purchase parts or accessories, please contact us at
www.spectrumfurniture.com
1-800-235-1262

Thank you for choosing Spectrum products!

Touchboards

205 Westwood Ave, Long Branch, NJ 07740
Phone: 866-94 BOARDS (26273) / (732)-222-1511
Fax: (732)-222-7088 | E-mail: sales@touchboards.com



Spectrum Industries, Inc.
Chippewa Falls, WI 54729, USA



Safety



Read this owners manual before assembly or operation
 Do not allow children to move cart
 Move slowly and carefully when mobile

Hardware package contents

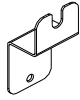

(4) 0105648
Cord Wrap Bracket



(12) 052605
1/4-20 x 15mm JC Bolt



(100) 0102376
11" Zip Tie



(1) 025039
4mm Hex Wrench

Tools Required



4mm Hex Wrench
(included)



Phillips Screwdriver

Assembly / Setup

1. Handle and Cord Wrap Bracket Installation

- A. Determine which side of the cart you would like the handle to be mounted (left or right-side) and attach the handle to the side panel with (4) 1/4-20 x 15mm JC Bolts, and tighten securely. **Figure 1A.**
Note: If you have two swivel, and two rigid wheels on your cart (SR-version,) mounting the handle on the same side of the cart as the two swivel wheels will provide more control of the cart when mobile.
- B. Attach the cord wrap brackets to the side panels (left and right-side) with 1/4-20 x 15mm JC Bolts as shown and tighten securely. Be sure the brackets are facing away from each other as shown.
- C. Power cords can be routed through the lower side panel grommet as shown in **Figure 1B.**
- D. Wrap excess cord around the cord brackets as necessary.

Tools Required:



4mm Hex Wrench

Note: Handle must be installed before cord wrap brackets.

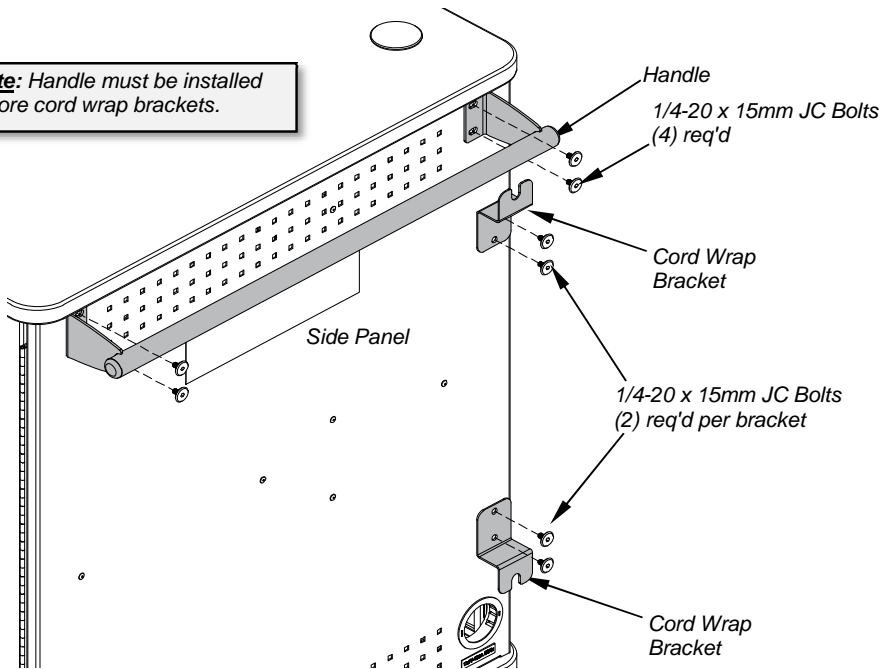

Figure 1A

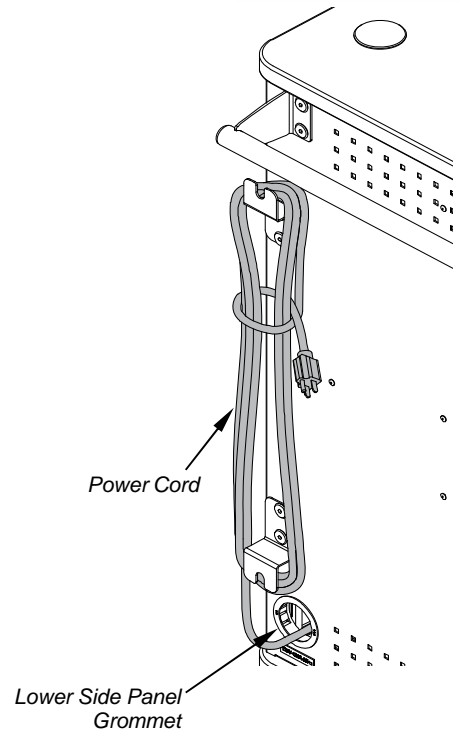

Figure 1B

2. Cord Management & Setup

- Open the rear door(s). Be sure the cart power strip cord(s) are unplugged.
- Attach the laptop charge transformers to the cord management trays using the included zip ties and cord management slots. **Figure 2A & 2B.** (Excess cords can be bundled with the transformer if necessary.)
- Charge cords can be routed to the laptops several different ways depending where the charge jacks are located on your particular laptops. **Figure 2C.** Cords can be anchored with the included zip ties as shown.
- With the power strip switch in the 'OFF' position, plug the laptop transformers into the cart's power strip(s), and the transformers into the laptops.

Note: On vLT-15 carts, the 16-outlet power strip can be mounted on the left or right-side of the cart if necessary with the 4 mounting screws.

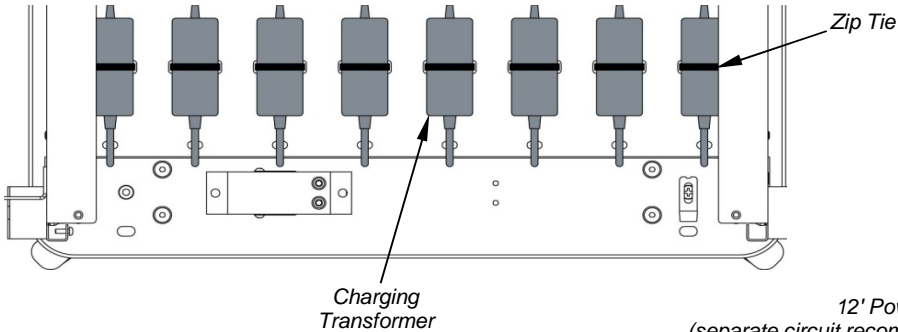

Figure 2A

Top view of Cord management tray

12' Power Cord
(separate circuit recommended for each power strip, unless used in conjunction with alternating cycle timer)

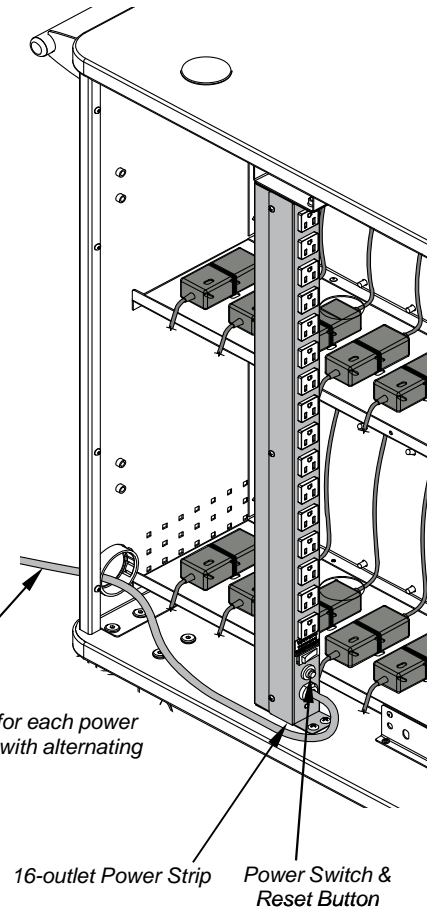

Figure 2B

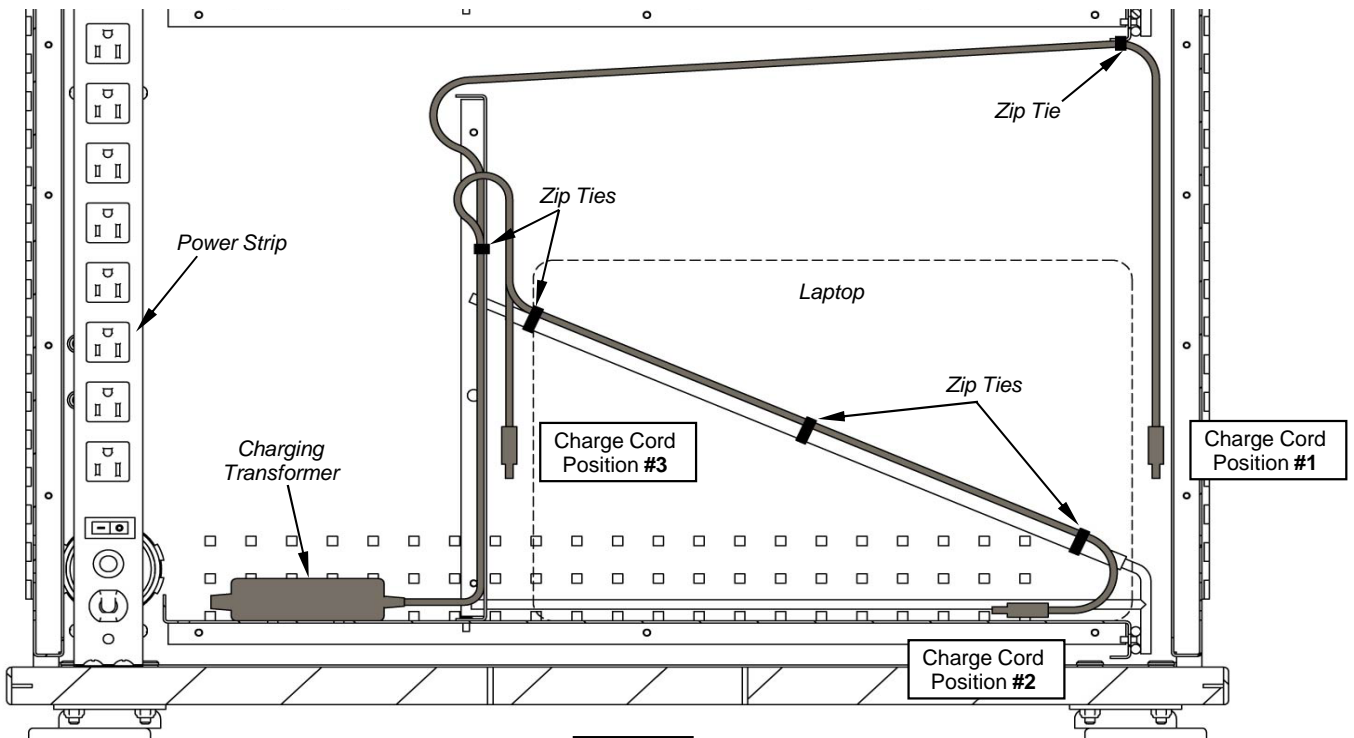

Figure 2C

Laptop Charging (without optional timer or cord reel)

- With the power strip switch turned to the 'OFF' position, plug the power strip into a wall outlet. **Figure 3.**
- With power strip and laptops plugged in, flip the power switch to the 'ON' position to begin charging.

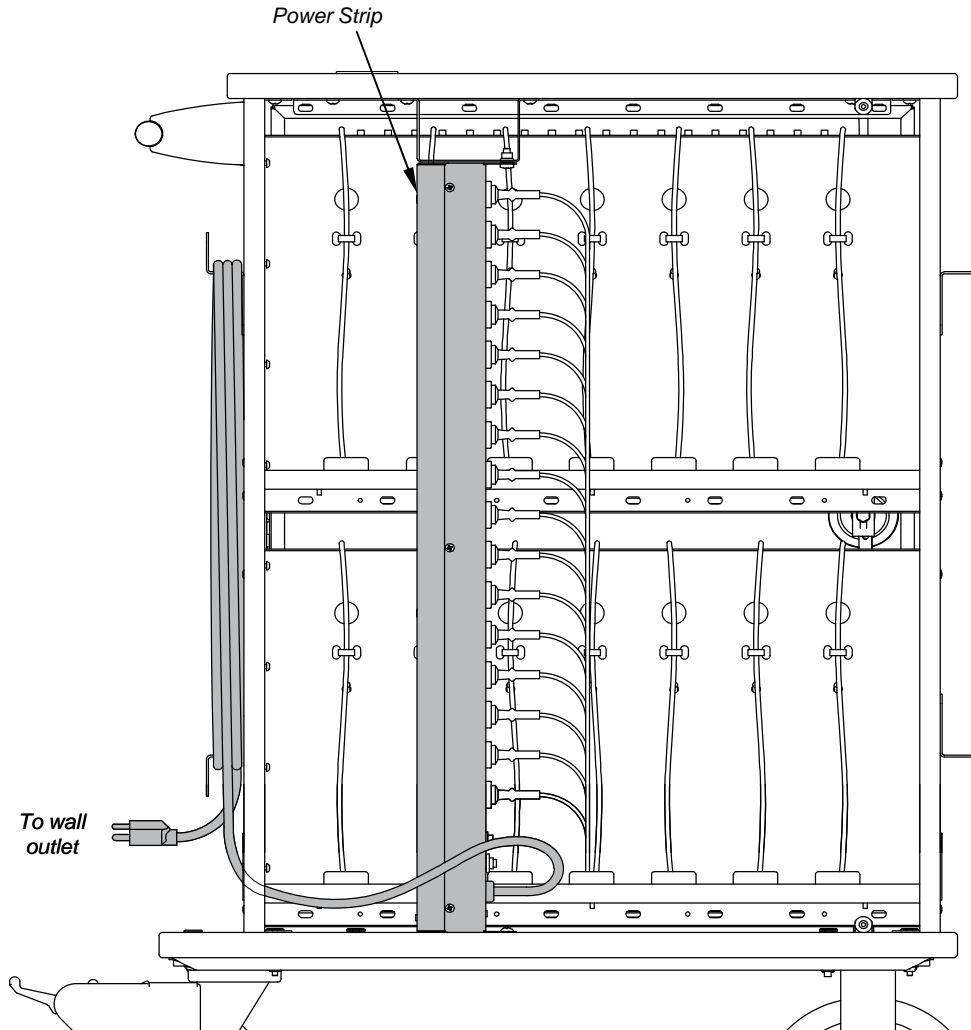

Figure 3

Moving the Cart

- Before moving the unit, unplug all power cords and wrap around the cord management brackets.
- Be sure the casters are in the unlocked position and the door are closed.
- Move the cart using the handle. After moving, lock the casters.

Touchboards

205 Westwood Ave, Long Branch, NJ 07740
 Phone: 866-94 BOARDS (26273) / (732)-222-1511
 Fax: (732)-222-7088 | E-mail: sales@touchboards.com

WARNING ATTENTION

CAN TIP OVER RESULTING IN RISK OF INJURY, DO NOT ALLOW CHILDREN UNDER 16 TO MOVE CART. MOVE CART SLOWLY.

PEUT BASCULER, ENTRAINANT UN RISQUE DE BLESSURE, NE LAISSEZ PAS LES ENFANTS DE MOINS DE 16 POUR DEPLACER PANIER. DEPLACER PANIER LENTEMENT

ONLY ADULTS SHOULD MOVE THIS UNIT SEULS LES ADULTES DEVRAIENT PASSER CET APPAREIL	APPLY MOVING FORCE ON NARROW DIMENSION APPLIQUER UNE FORCE EN MOUVEMENT SUR LA DIMENSION	NEVER APPLY FORCE AT TOP ALWAYS PUSH NEAR MIDDLE JAMAIS EMPLOYER LA FORCE EN HAUT TOUJOURS POUSSER PRES DU MILIEU	PUSH, DO NOT PULL POUSSER, NE TIREZ PAS

vLT-15 Options

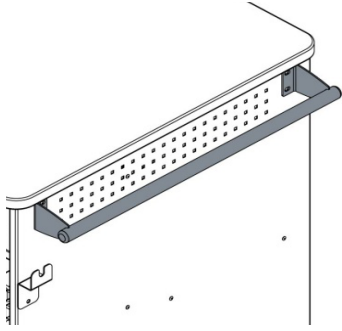

Additional Steel Handle
(mounts on left or right-max 2 per unit) 27"W
55265

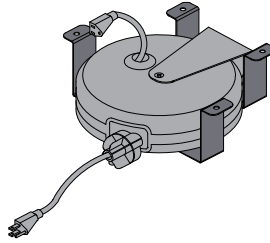

15' Retractable Cord Reel Kit
(15-amp)
55326

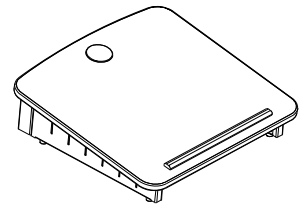

Lectern Riser
18"W x 17¹³/₁₆"D
95002



Custom-Cut Logo
(Typical logo location on rear door)
55141



Velcro® Strap Kit
(16) 3/4" x 12", and (32) 3/4" x 5"
Velcro® Straps
95004



Replacement Key Set
55142

Warranty

WE WILL MAKE IT RIGHT FOR YOU!

We guarantee all Spectrum products to be free of all defects in materials and workmanship, for the original owner, for a period of **ten years**. Any item deemed defective by Spectrum or the original manufacturer, under normal use conditions, will be repaired or replaced at Spectrum's discretion. This warranty applies to all products manufactured and distributed by Spectrum except the products listed below.

DESIGNED FOR INDOOR USE ONLY - Spectrum's products have been designed and constructed for indoor use only. Moving or using outdoors, or on excessively rough surfaces, may cause damage to the products and may void the warranty. If an outdoor application is desired please contact us to discuss potential custom design solutions.

Spectrum is committed to provide complete customer satisfaction. Each of our products are manufactured from the best materials available and each product is stringently monitored throughout the production process through our P.A.C.E. program (Product Assurance to meet Customer Expectations).

Our Customer Service Help Line 1-800-235-1262 is ready to provide immediate attention to any questions, comments or concerns. We are available to answer your calls Monday through Friday from 7 am to 5 pm CST. In addition your product comments or concerns are welcome via e-mail at: spectrum@spectrumfurniture.com.

Items that have a varying warranty include, but are not limited to, the following:

- Adjustable Crank/Electric Desk Legs (1 yr)
- Flat Panel Desk Gas Cylinders (1 yr)
- Adjustable Height Chair Parts – including frames, gas cylinders, wood and plastic parts, and control handles (7 yrs)
- Adjustable Height Chair Parts Casters (2 yrs)
- Adjustable Height Chair Upholstery - In-Stock Upholstery (2 yrs)
- Adjustable Height Chair Upholstery - Graded-In Fabrics and C.O.M (no warranty)
- Height Adjustable Columns and Lifts (1 yr)
- General Use Casters (1 yr)
- Electrical – ECA (1 yr)
- Electrical - Power Strips (1 yr)
- Electrical Surge Suppressors (lifetime)
- Electrical - Retractable Power Cords (1 yr)
- Keyboard/Mouse Trays (1 yr)
- Flat Panel Monitor Arm – General Parts (5 yrs)
- Flat Panel Monitor Arm – Gas Cylinders (2 yrs)
- CRT Monitor Arm (1 yr)

The warranty, as stated above, is effective as of 05/28/2009

Touchboards

205 Westwood Ave, Long Branch, NJ 07740
Phone: 866-94 BOARDS (26273) / (732)-222-1511
Fax: (732)-222-7088 | E-mail: sales@touchboards.com



SCIENTIFIC CERTIFICATION SYSTEMS
SCS-IAQ-02352



SPECTRUM
INDUSTRIES INC.

925 First Avenue, PO Box 400, Chippewa Falls, WI 54729 Ph: 1-800-235-1262 Fax: 1-800-335-0473

E-mail: spectrum@spectrumfurniture.com web: www.spectrumfurniture.com