

Technical Specifications

55418

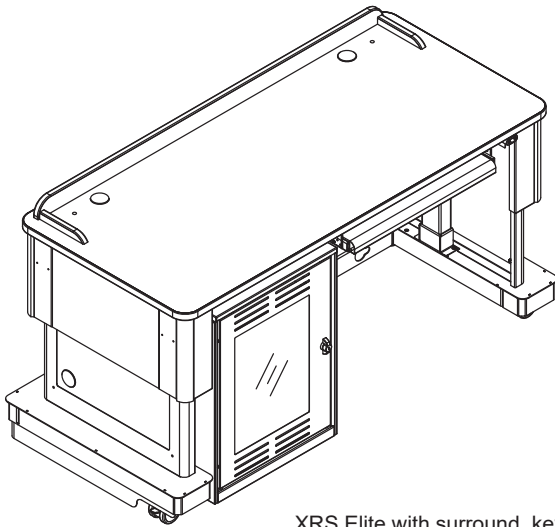

XRS Elite with surround, keyboard tray, and rack cabinet installed on left (shown retracted)

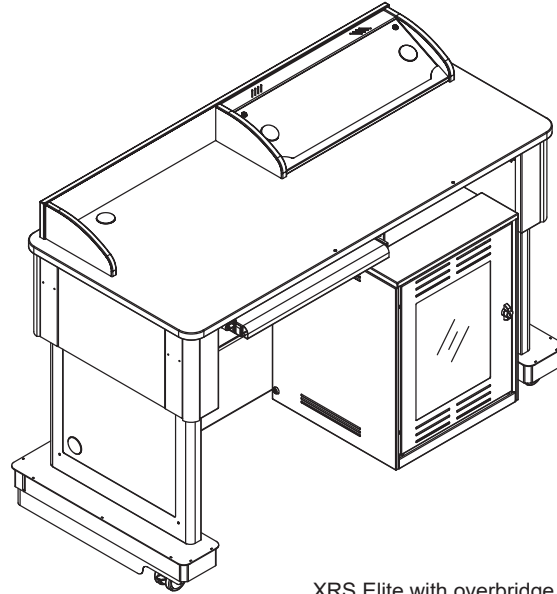

XRS Elite with overbridge, keyboard tray, and rack cabinet installed on right (shown extended)

Use the Freedom XRS Elite Lectern where worksurface height adjustment, ADA compliance, and rack rail equipment storage is required. Electric actuators provide worksurface height adjustment from 32"-40". The lectern is available with a surround, or an overbridge. Rack cabinet can be integrated with electronics off-site then docked under the left or the right side of the lectern when ready. Additional options like flip-up shelf, customized logo panel, worksurface power module, and keyboard tray are available.



Features and Benefits

Lectern:

- Electric adjustable-height worksurface adjusts between varying seated or standing-use heights (32"-40"H)
- ADA-compliant
- Scratch and impact-resistant high-pressure laminate top provides a durable, useful worksurface
- Surround on worksurface provides privacy and styling
- Overbridge version with blank panel allows custom cutouts and installation of electronics (overbridge version only)
- Worksurface grommet holes and cable grommets throughout lectern provide cable access
- Pre-drilled monitor arm mounting holes allow installation of a monitor arm (2 on surround version, 1 on OB version)
- Wiring channel provides easy cable routing
- 3" swivel locking Twin-Wheel (TW) casters
- 2" grommet in each side panel provides cord access
- All internal wiring can be accessed from the instructor-side
- Cable grommets throughout and wiring channel provide cable access and wiring
- Kick panel and wiring channel protect cables during worksurface movement
- Replaceable base skirt panels hide casters (customer-installed)
- Removable locking audience-side panel
- Optional customizable logo panel simplifies adding or changing logos
- Optional pull-out worksurface / keyboard tray can be used as a keyboard tray or storage drawer
- Optional flip-up shelf provides a convenient additional worksurface (customer-installed)

Rack Cabinet:

- Rack-rail mounting (14RU front, 9RU rear) simplifies installation for any equipment configuration
- The cabinet allows rack-mount equipment to be installed remotely, then brought to the lectern-attaching under the left or right side of the lectern
- Casters under the cabinet provide easy repositioning for quick and easy access
- Keyed locking rack door provides security and easy-access
- Ventilated panels keep equipment cool
- Quick-release instructor side acrylic door provides monitoring of internal equipment, and can be removed to provide full access to rack equipment
- Symmetrical acrylic door can be attached to the left or right side of the cabinet

Misc:

- Durable powder coated steel chassis provides a long-lasting finish
- Warranted to be free of all defects in materials and workmanship for 10 years
- Designed and assembled in Chippewa Falls, WI, USA

Color Options

Available in Spectrum Expressions colors.
See spectrumfurniture.com for complete color information.

Ordering Instructions

Spectrum has designed this product to receive the useful options shown here.
To ensure your options are ordered correctly please call 1-800-235-1262.

Construction

- The worksurface is constructed from 1" thick composite board with .030" high-pressure laminate on one face, and a balancing phenolic backer on the opposing face
- Metal components consist of 16-gauge steel
- Worksurface edges are covered with 3mm vinyl edgeband
- All metal components are finished with a scratch-resistant powder coat epoxy
- Solid wood corner trim
- Each Freedom XRS Elite Lectern ships assembled with casters on its own skid. Customer-installed base skirt and rack cabinet.

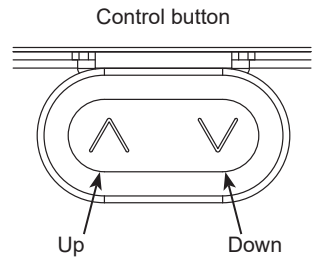

Specifications

Lectern worksurface height adjustability (floor to top of worksurface)	40"H [101.6 cm] (fully-raised) 32"H [81.3 cm] (fully-lowered)	
Rack Cabinet (optional)	<ul style="list-style-type: none"> • Front rack rail: 14RU • Rear rack rail: 9RU • Available rack depth (nominal): 17"D [43.19 cm] • Locking door can be flipped to be hinged left or right 	<ul style="list-style-type: none"> • Vented panels provide equipment cooling • Open back provides access • One rack cabinet can be attached to the left or right side of the lectern
3" Twin Wheel casters	Weight capacity 165 lb [74.9 kg] each	
ADA-compliance*	 <p>Knee clearance: 30"W [76.17 cm] x 22"D [55.8 cm] x 29"H [73.7 cm] (1 person per lectern)</p>	<p>Note: Worksurface with keyboards must be raised to provide ADA clearance</p> <p><i>*Minimum ADA guidelines for knee clearances are 30"W [76.2 cm] x 19"D [48.3 cm] x 27"H [68.6 cm]</i></p>
Electrical	<ul style="list-style-type: none"> • Range of motion: 8" [20.3 cm] • ~10 seconds from fully-lowered to fully-raised • Inverter: 120V @ 60Hz, max output 300 watts • Motors: 18V / 10 amps • Typical electrical load during operation: 4.3 amps @ 120 VAC • Anti-collision protection 	<ul style="list-style-type: none"> • 11' [335 cm] nominal 3-wire power cord • Max load: 800N (180 lb) [82 kg] per actuator total lift capacity: 360 lb [163 kg] • Actuators feature non-hydraulic, permanently lubricated screw jacks • Actuators rated for 20,000 cycles • Approved according to EN 60335-1 and UL 962
Unit weights (nominal)	295 lb [134 kg] - Lectern (without rack cabinet)	
Shipping weights (nominal)	361 lb [164 kg] - 445 lb [202 kg] (depends on configuration)	

Specifications subject to change without notice

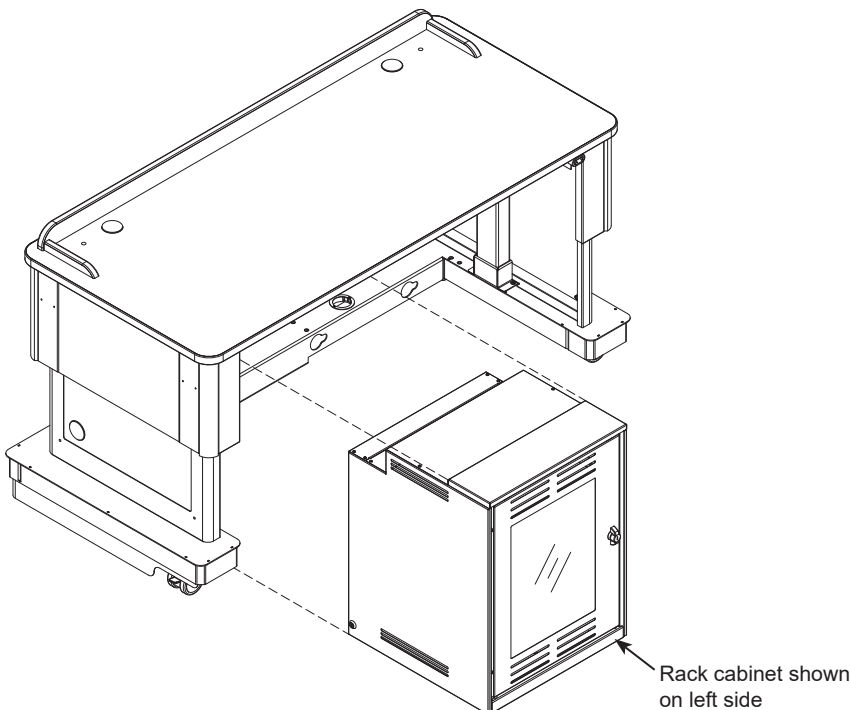

Note: The Freedom XRS Elite Lectern is not designed for use with cord reels or surface-mount cord reel accessories.

Note: CPU slings cannot be used with Freedom XRS Elite lecterns because of mounting and ADA-compliance considerations. If a CPU is necessary, it can and should be installed into the rack cabinet using a rack-mount shelf. See website for rack-mount accessories.



Use caution when raising or lowering lectern!

Bottom view

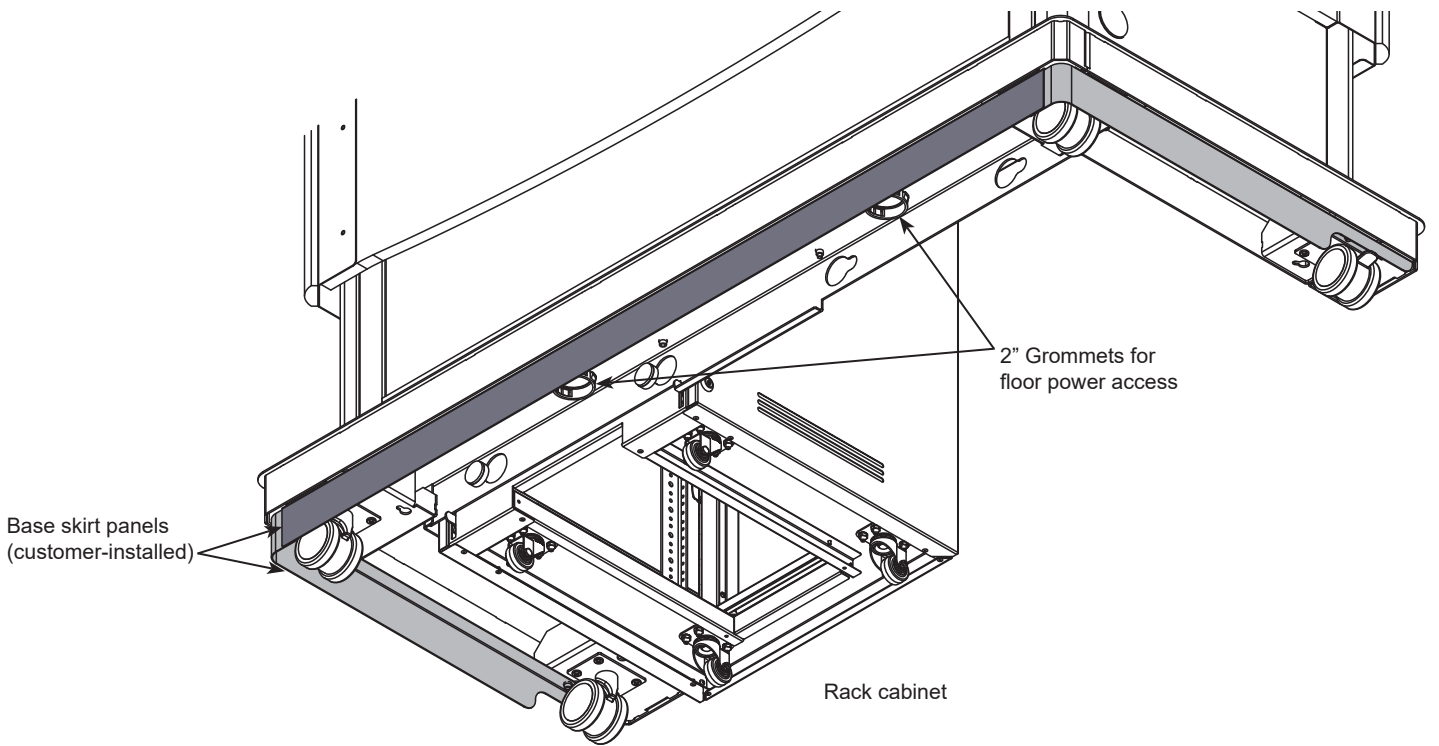

3" Twin-Wheel caster (TW)

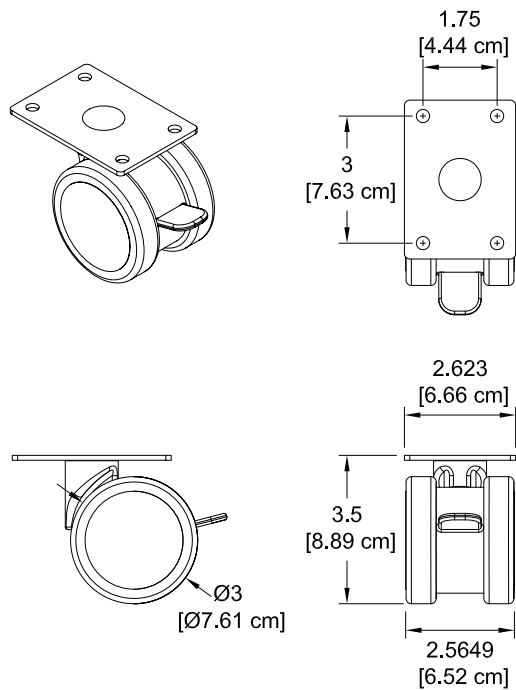

Lectern Style

ORDER CODE S1 = Surround

- Surround
- Two 2" grommets (with covers)
- Two .375" holes (with plugs) for worksurface monitor arm mounting

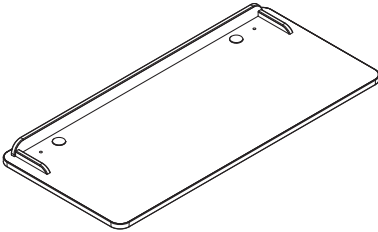

ORDER CODE B2 = Overbridge Right

- Overbridge with blank insert panel for custom cutouts (see p.13 for dimensions). (Overbridge not available separately)
- Two 2" grommets (with covers)

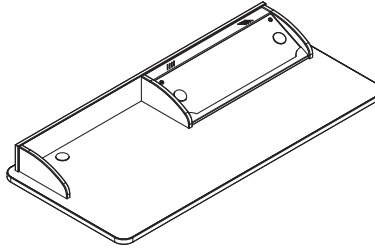

ORDER CODE B3 = Overbridge Left

- Overbridge with blank insert panel for custom cutouts (see p.13 for dimensions). (Overbridge not available separately)
- Two 2" grommets (with covers)

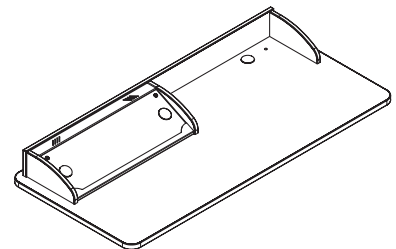

Instruction Orientation

ORDER CODE L = Left instructor

Note: The keyboard tray, wiring panel, control box, and control button always stay together on the same side as shown.

ORDER CODE R = Right instructor

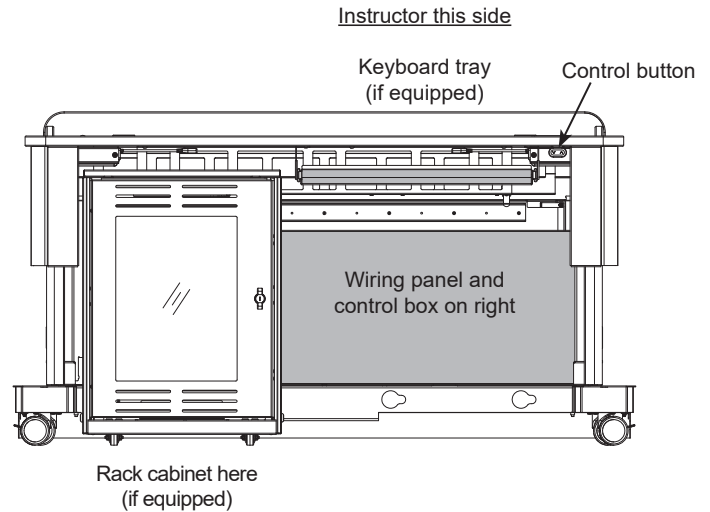
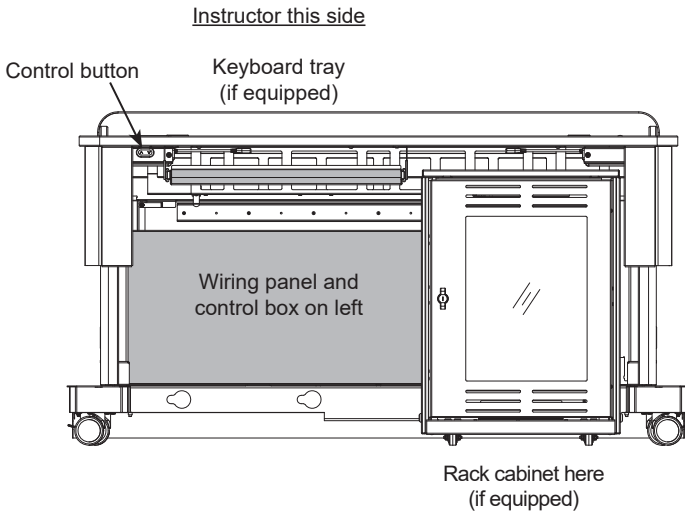

Rack Cabinet

ORDER CODE 0 = None

ORDER CODE 3 = Yes

Rack Cabinet

- One rack cabinet attaches to the left or right side of the XRS Elite Lectern (opposite keyboard tray and wiring panel)
- Locking door can be flipped to be hinged left or right
- Locking side hatches
- Open back
- Acrylic panel in door
- Casters under the cabinet provide easy repositioning for quick and easy access (not intended for long-range transport).
- Customer-installed

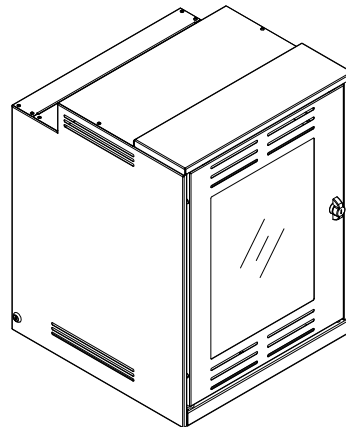

Front rack rail:	14RU
Rear rack rail:	9RU
Dimensions:	21.1"W [53.5 cm] x 21.7"D [55.1 cm] x 28.5"H [72.4 cm]
Unit weight:	55 lb [25 kg]

Note: If rack rail mounting is needed in the lectern, the rack cabinet must be specified. The lectern does not provide any rack-mount capabilities without the cabinet.

Flip-Up Shelf (Customer-installed)

ORDER CODE 0 =	None
ORDER CODE C =	One shelf, Matching laminate
ORDER CODE D =	Two shelves, Matching laminate
ORDER CODE E =	One shelf, Chalk white dry erase (WD)
ORDER CODE F =	Two shelves, Chalk white dry erase (WD)

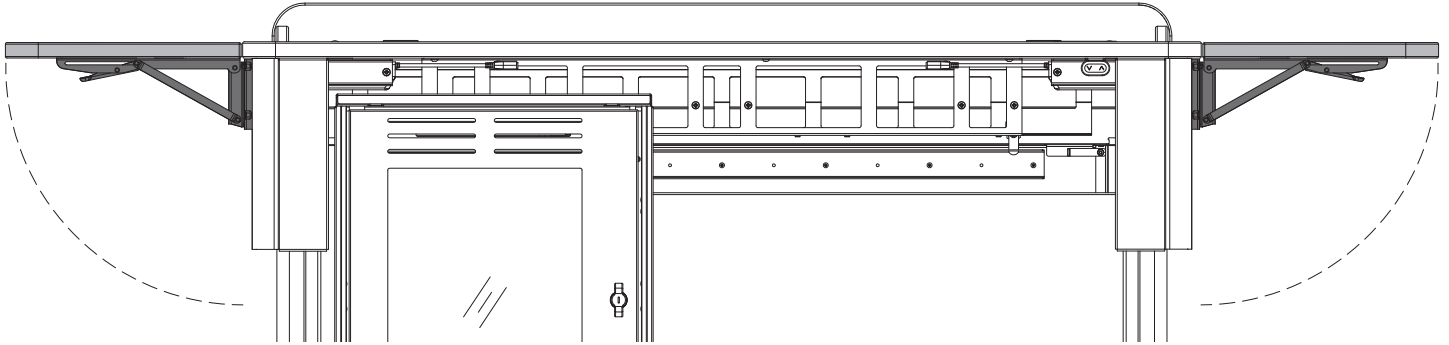

- Shelf hinges lock into place in the upright position
- Shelf installed level with worksurface
- Available in matching, or White Chalk Dry Erase laminate.
(Flip-up shelves configured with white laminate will have the same edgeband color as the worksurface.)
- Shelf is customer-installed

Weight capacity: 35 lb [15.9 kg]

Dimensions: 15.25"W [38.7 cm] x 24.625"D [62.5 cm] x 1"H [2.54 cm]

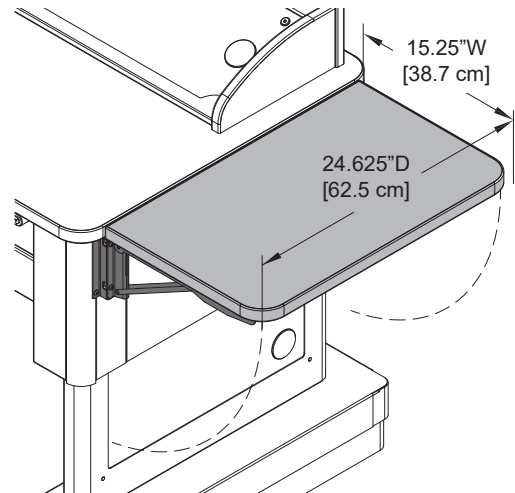

Keyboard Tray Option

ORDER CODE 0 =	None
ORDER CODE 1 =	Yes

Pull-out Keyboard Tray

- Installed in left or right position (opposite rack cabinet) using pre-drilled holes
- Tray can be installed and used as a keyboard tray or flipped and used as a storage drawer using pre-drilled mounting holes under the worksurface.
- Wire management slots in tray
- Max 1 tray per Freedom XRS Elite
- 24"W [61 cm] x 11.625"D [29.5 cm] x 2.43"H [6.1 cm]
- 16 ga steel
- Unit weight: 8 lb [3.6 kg]
- Shipping weight: 10 lb [4.5 kg]

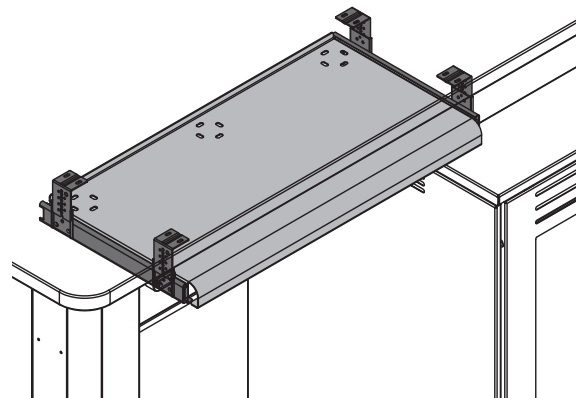

ORDER CODE 0 = None

ORDER CODE 1 = Power Module

- Factory-installed
- (2) AC receptacles (tamper-resistant)
- (2) USB ports rated at 2.1A each (10.5 watts)
- Aluminum housing and flange
- 10' 14AWG *3C power cord
- Worksurface cutout size: 5.65"W x 1.65"D
- ETL-certified

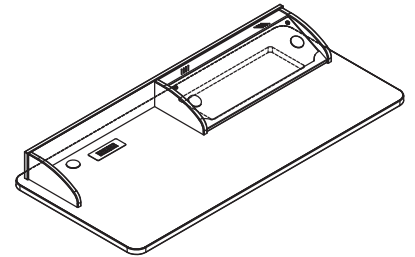
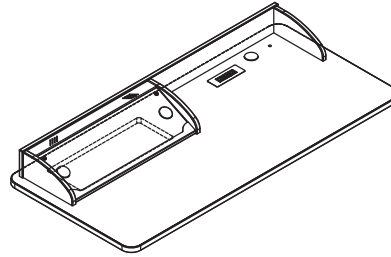
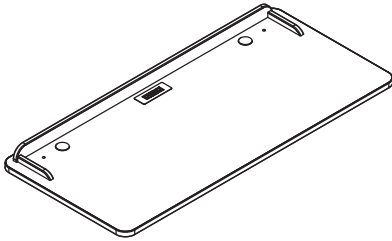
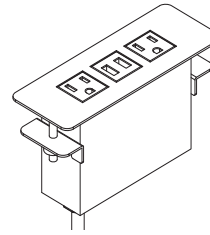

ORDER CODE 2 = Power Module - EM Wireless Charging Pad

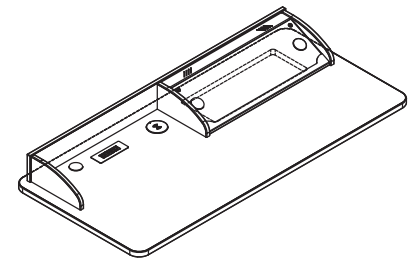
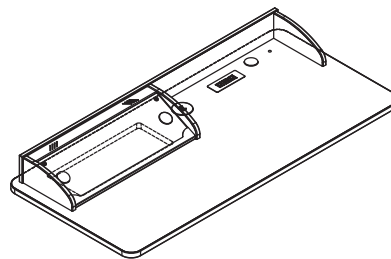
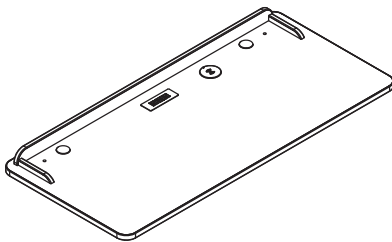
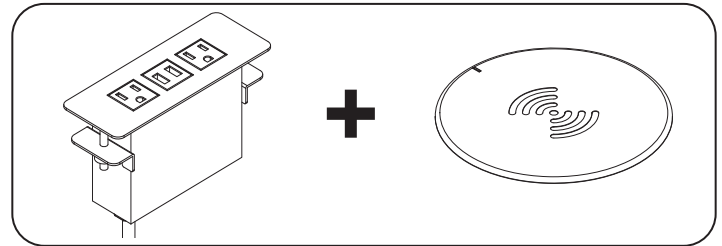

ORDER CODE 3 = EM Wireless Charging Pad

- Uses electromagnetic technology to charge Qi V1.2 compliant IC devices ("Qi enabled")
- LED to confirm pairing / charging
- Security tab prevents theft
- Includes 3" round cutout
- UL-certified

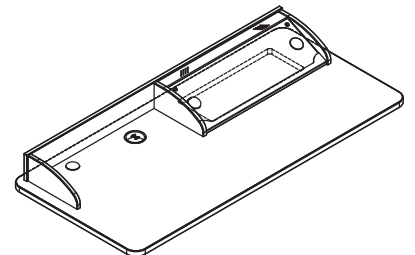
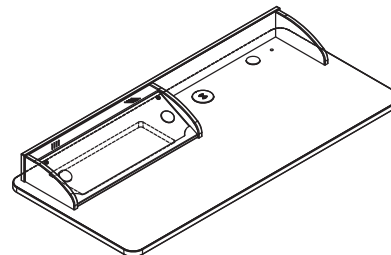
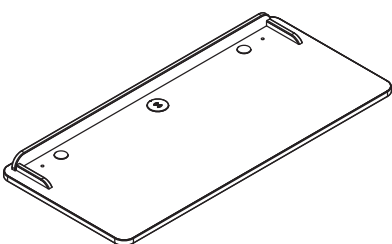
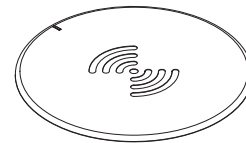

Custom Logo Panel

ORDER CODE 0 =	None
ORDER CODE 1 =	Yes (with <u>matching laminate</u> backer)
ORDER CODE 3 =	Yes (with <u>black laminate</u> backer)
ORDER CODE 4 =	Yes (with <u>white laminate</u> backer)
ORDER CODE 5 =	Yes-with printed backer

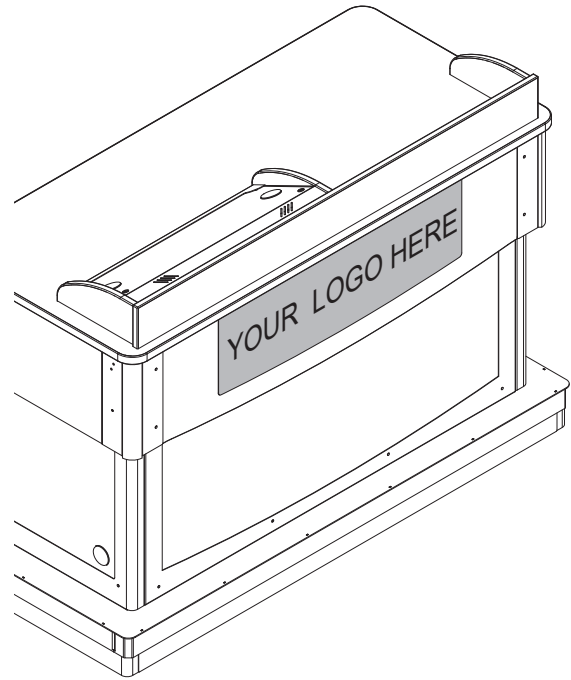

Customized Logo Panel

- Attaches to audience-side of lectern
- To get panel customized-contact Spectrum for details
- New logos require a first-time logo charge

Dimensions: 35.25"W [89.53 cm] x 9"H [22.86 cm]
 Available logo area: 35"W [88.91 cm] x 9"H [22.86 cm]

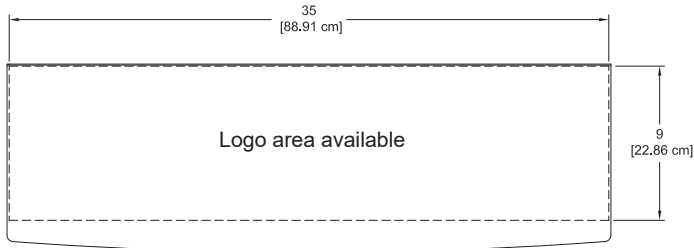

Power Module Color

ORDER CODE 0 = None

ORDER CODE B = Black



ORDER CODE S = Silver

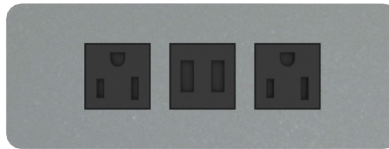

ORDER CODE W = White

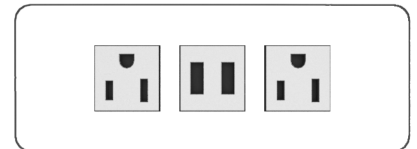

Custom Cutouts

ORDER CODE 0 =	None
ORDER CODE 2 =	Yes - in Worksurface
ORDER CODE 3 =	Yes - in OB Panel
ORDER CODE 4 =	Yes - in Worksurface and OB Panel

Contact Spectrum with device(s) / cutout(s) and preferred locations.

Freedom XRS Elite Lectern with surround

(shown with rack cabinet on left,
keyboard tray on right)

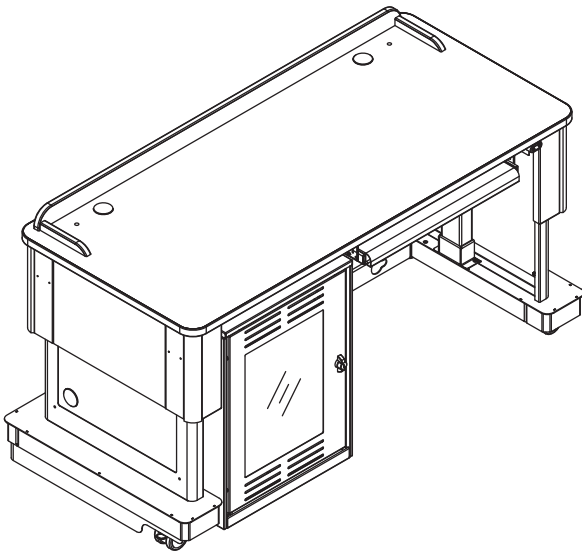

Note: Modified worksurface or overbridge insert panel cutouts should be reviewed by Spectrum to ensure clearance of brackets, keyboard slides, or other objects under the worksurface.

Note: The wiring channel has three sets of control box mounting holes-left, center, and right. If necessary, the control box can be relocated to provide space for installed components.

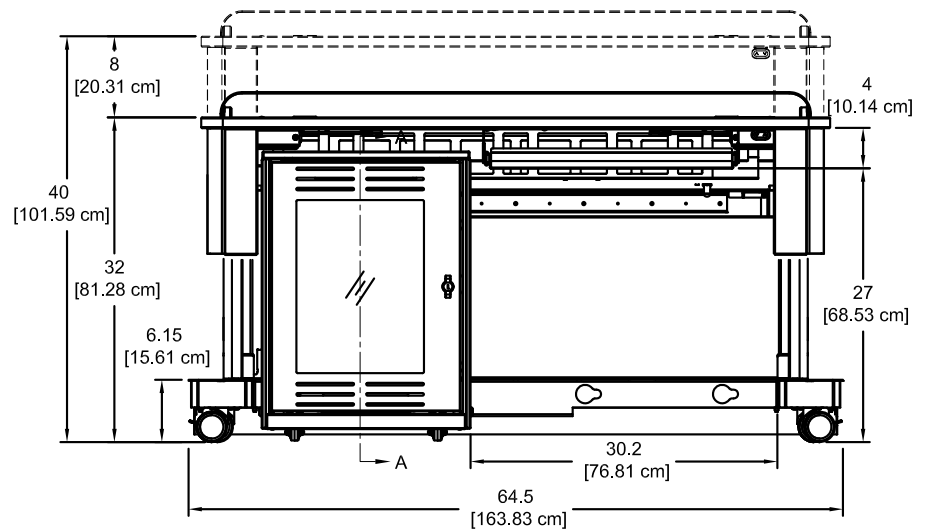
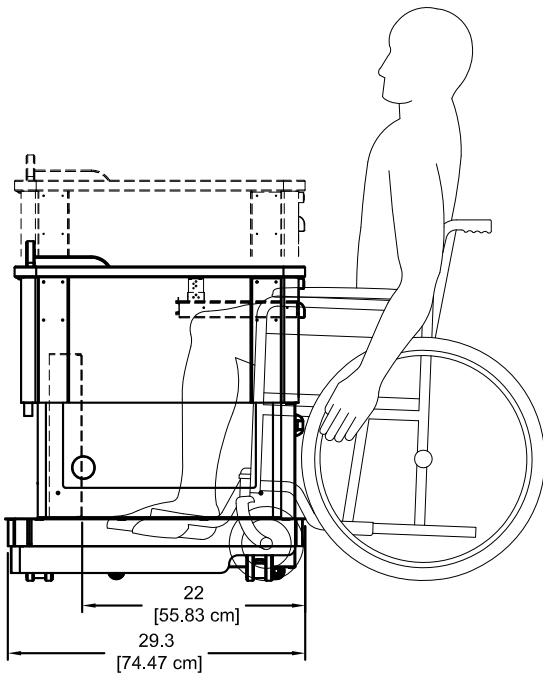
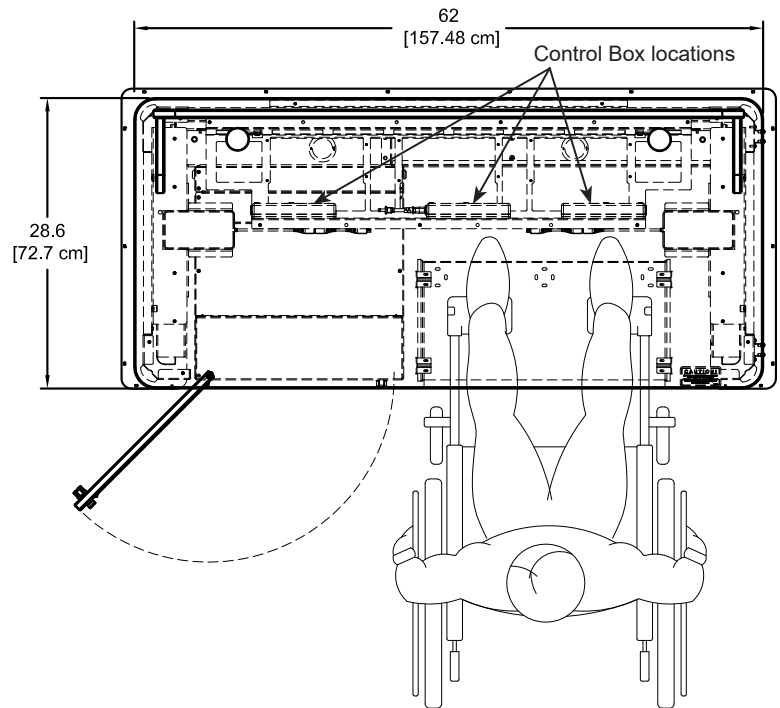

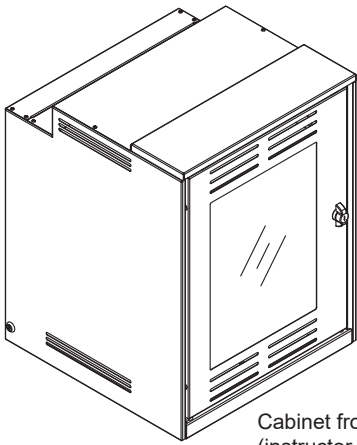

Cabinet front
(instructor-side)

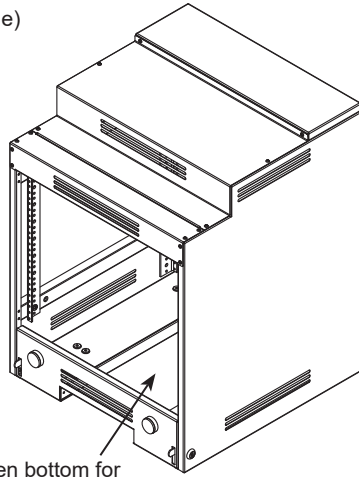

Cabinet rear
(open-back)

Note: Casters under cabinet provide easy repositioning for quick and easy access.

Open bottom for floor box access

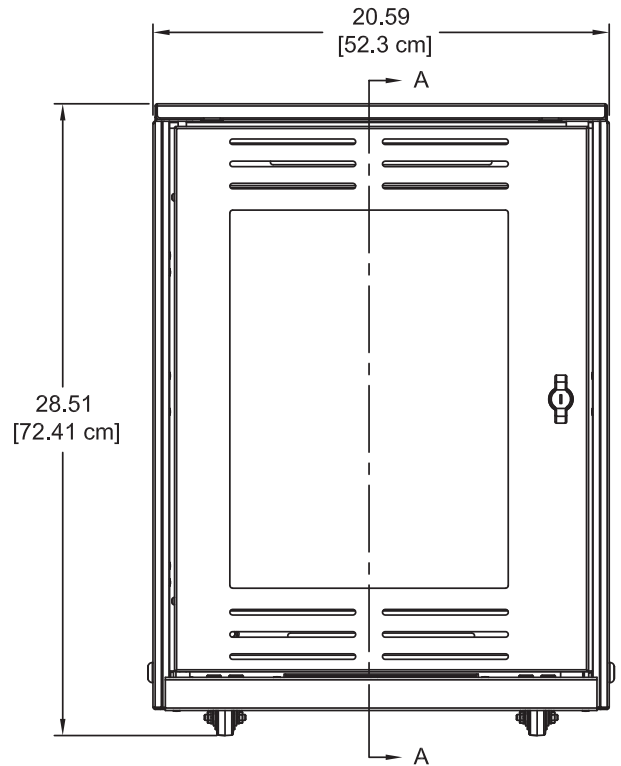
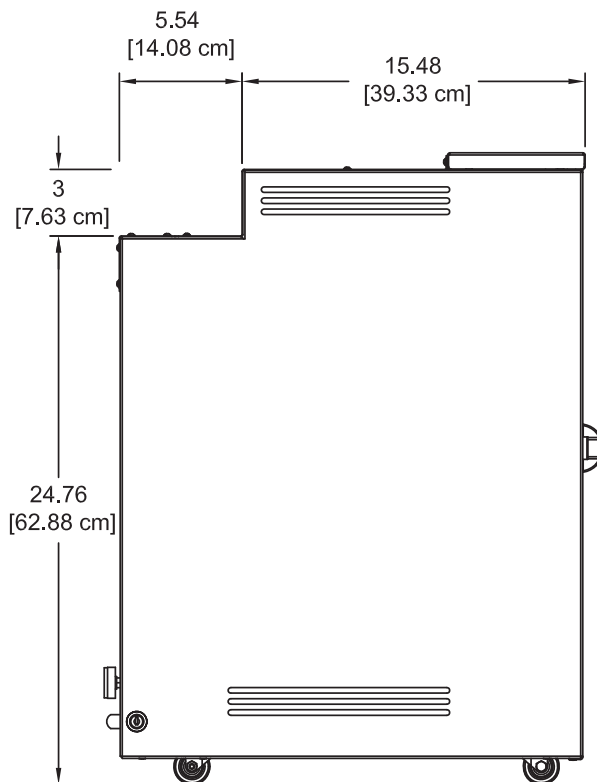
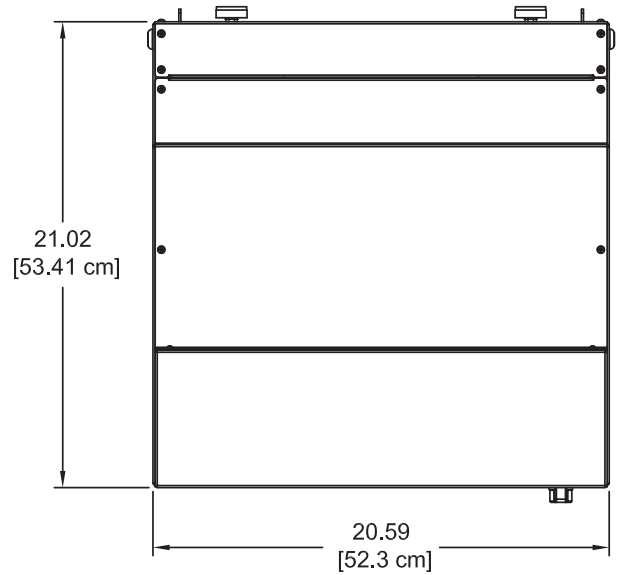

Rack Cabinet
Section view A-A

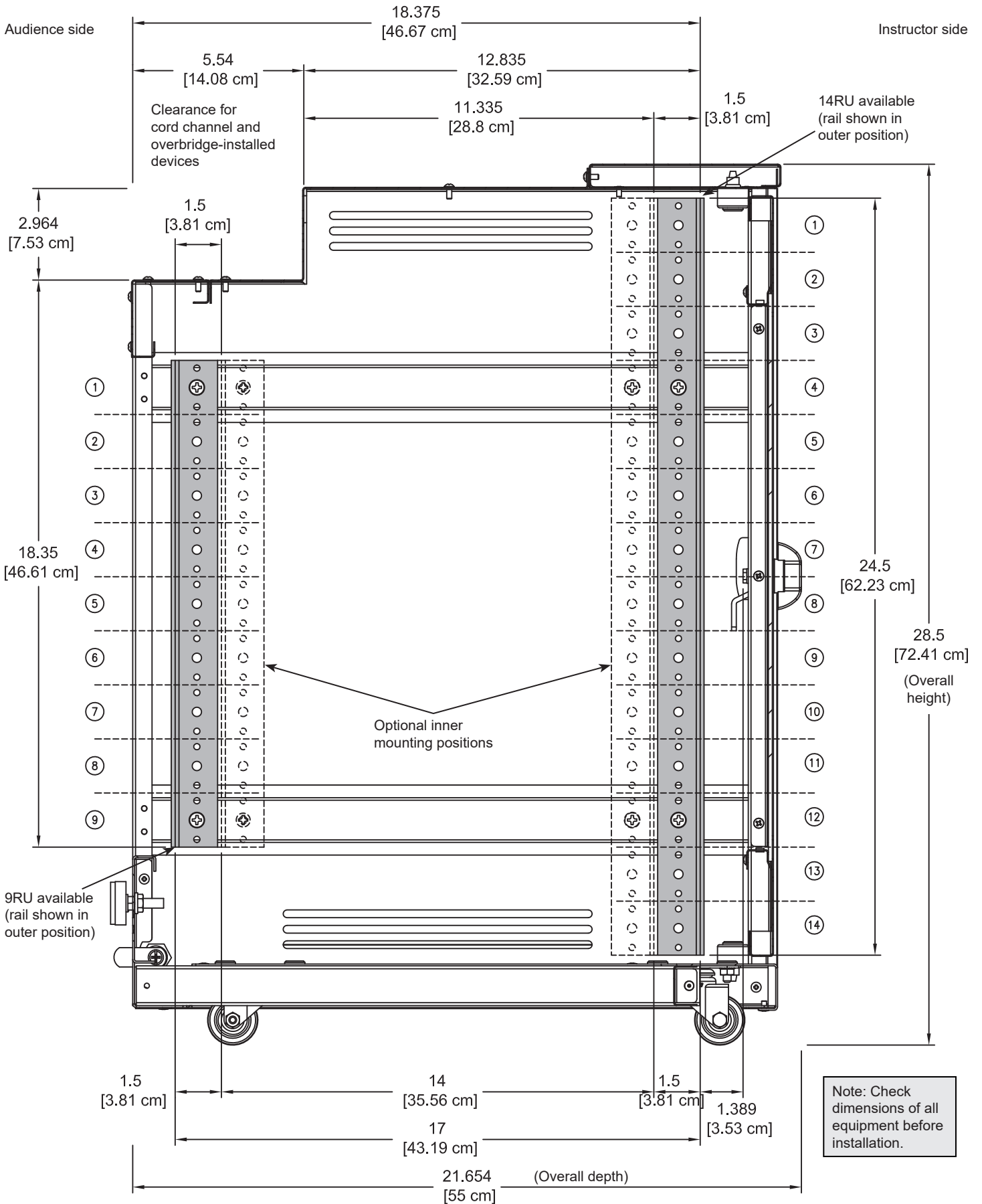

Freedom XRS Elite Lectern with Overbridge

(shown with rack cabinet on left, keyboard tray on right)

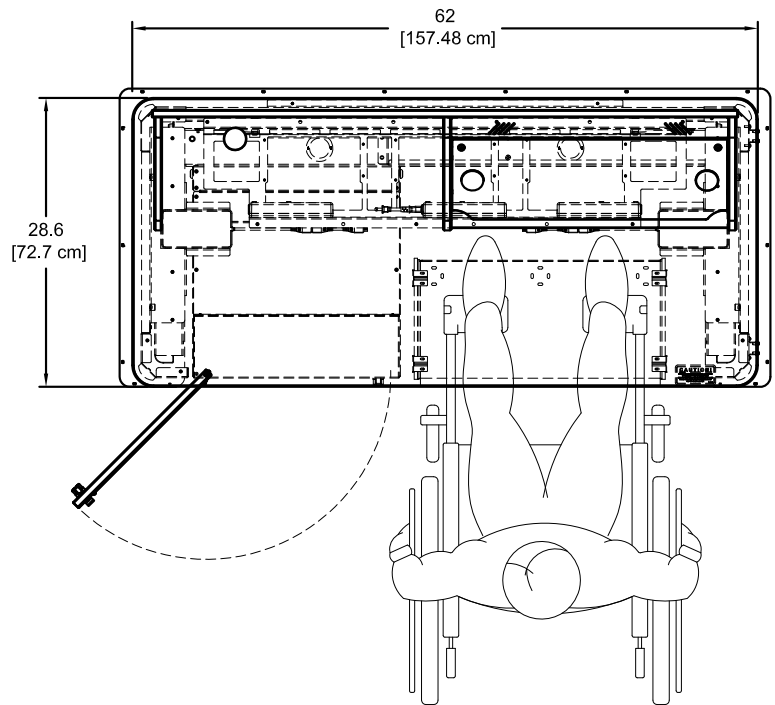
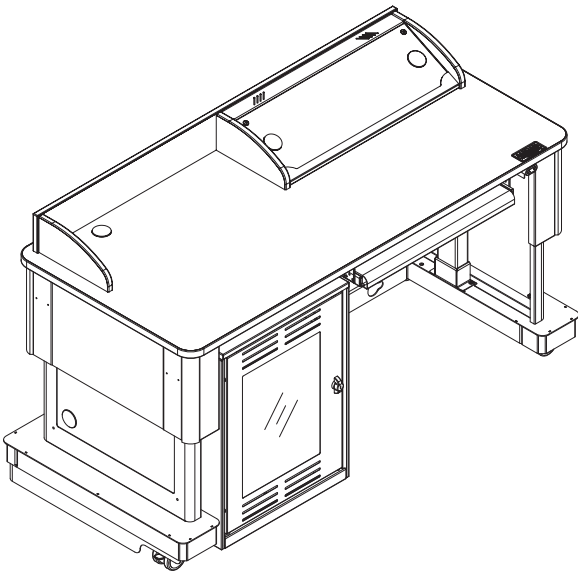

Note: Modified worksurface or overbridge insert panel cutouts should be reviewed by Spectrum to ensure clearance of brackets, keyboard slides, or other objects under the worksurface.

Note: The wiring channel has three sets of control box mounting holes-left, center, and right. If necessary, the control box can be relocated to provide space for installed components.

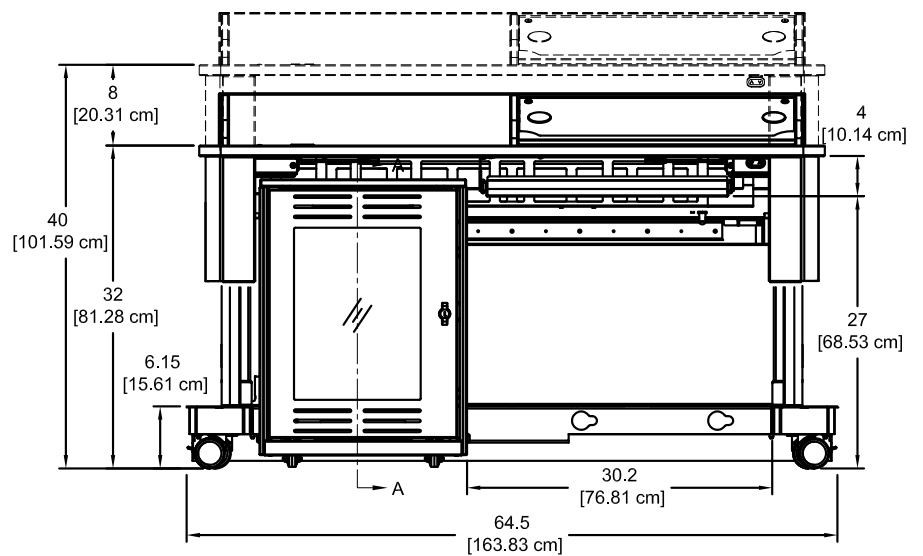
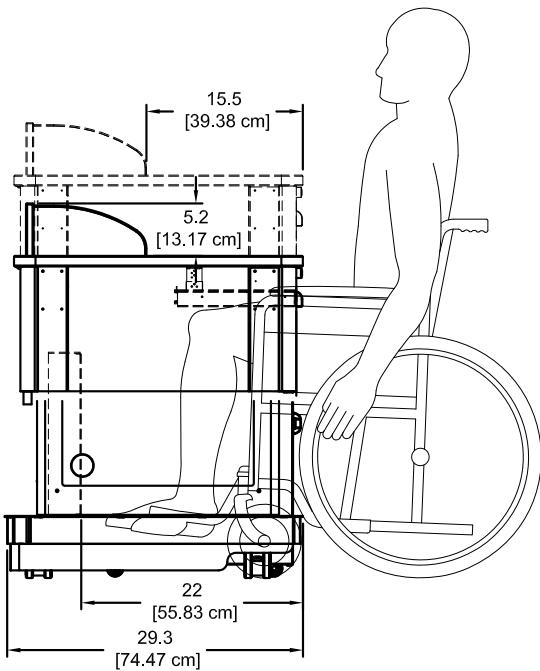

Freedom XRS Elite Lectern Overbridge Insert Panel Blank
(flat view)

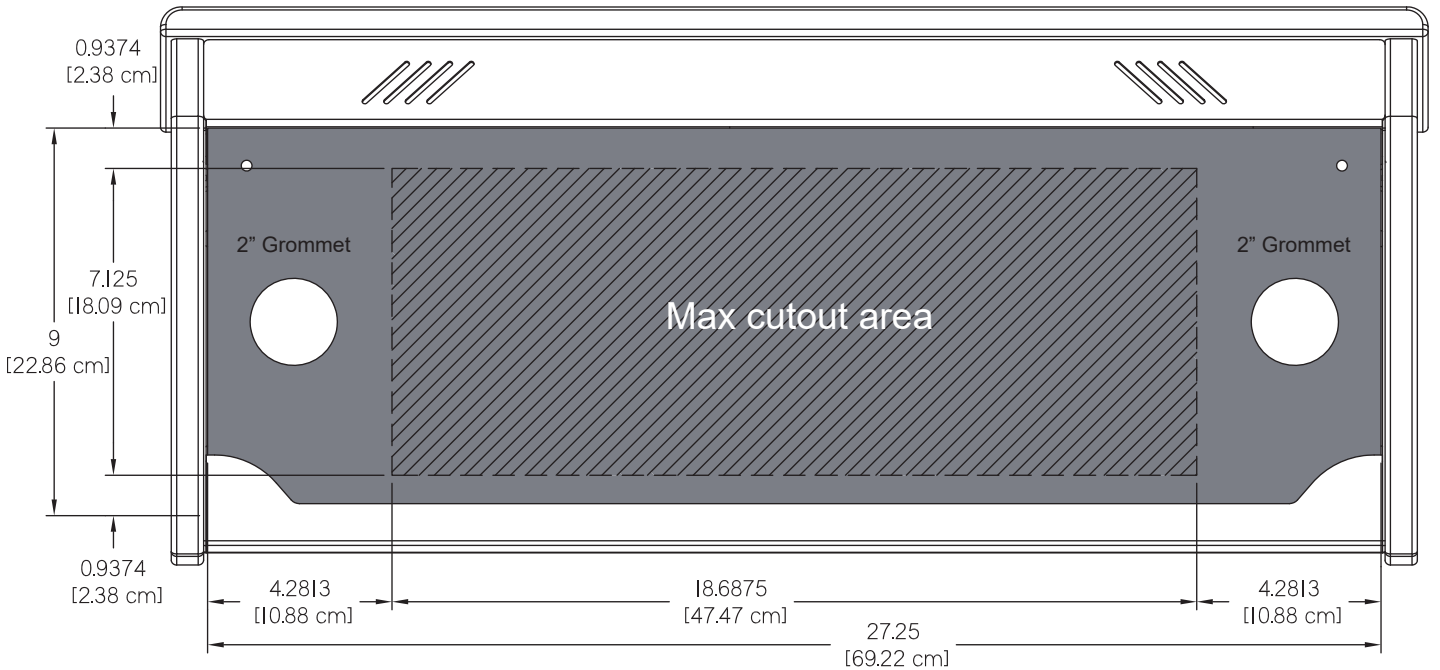

Overbridge
Section view B-B

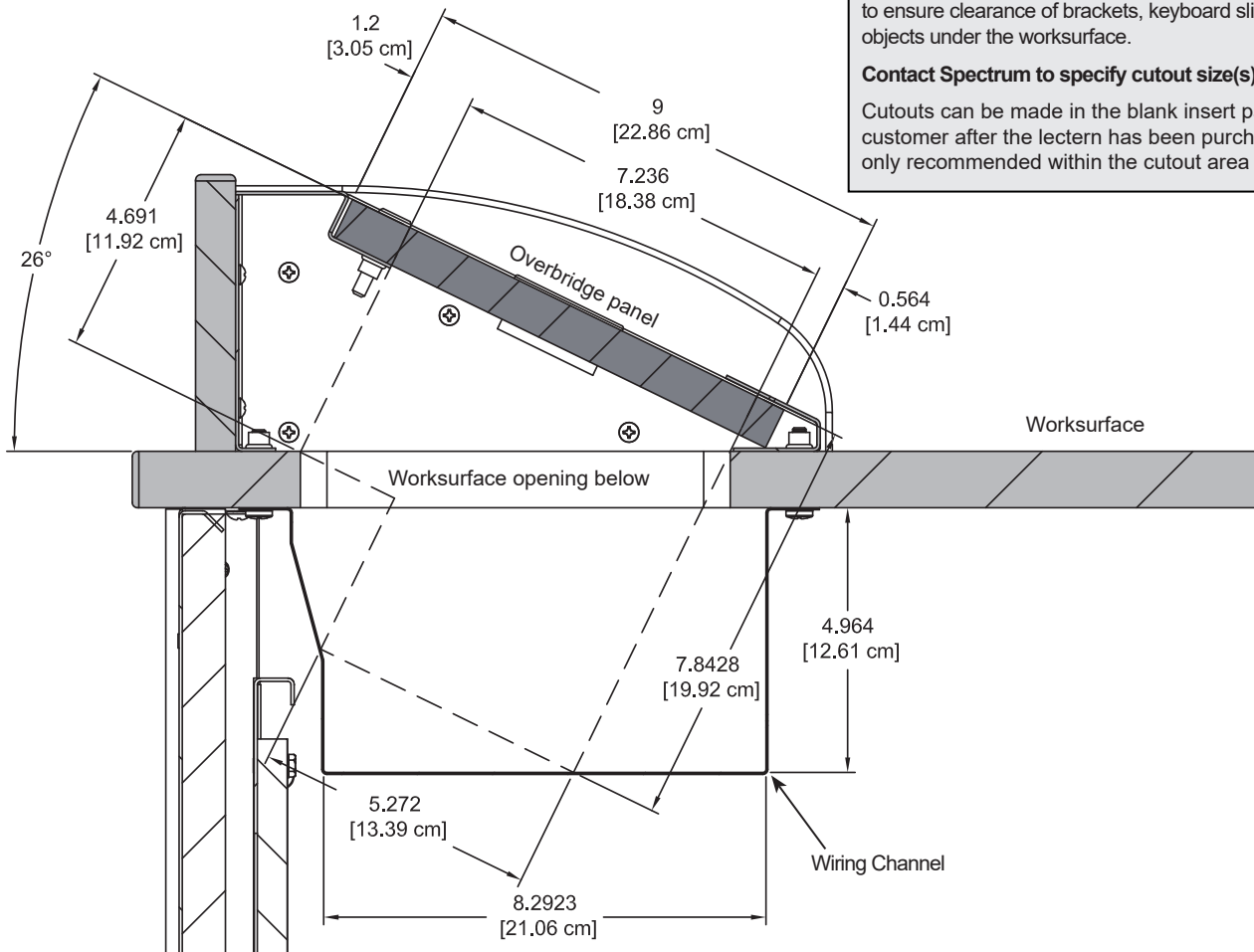

Note: The Overbridge Control Console™ has been designed for many of the currently available controllers on the market, however, modified cutouts should be reviewed by Spectrum to ensure clearance of brackets, keyboard slides, or other objects under the worksurface.

Contact Spectrum to specify cutout size(s) and location(s).

Cutouts can be made in the blank insert panel by the customer after the lectern has been purchased, but are only recommended within the cutout area shown.

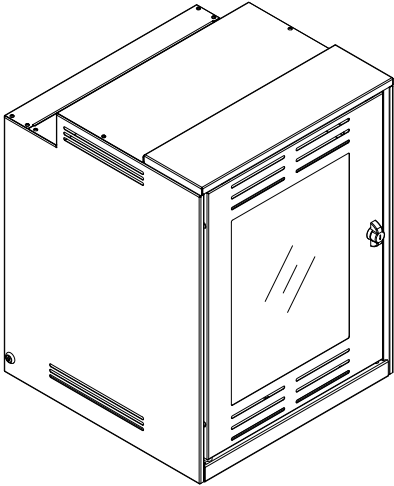

Rack Cabinet - 55419

- One rack cabinet attaches to the left or right side of the XRS Elite Lectern (opposite keyboard tray and wiring panel)
- Locking door can be flipped to be hinged left or right
- Open back
- Acrylic panel in door
- Vented panels provide equipment cooling
- Casters under the cabinet provide easy repositioning for quick and easy access (not intended for long-range transport).
- Customer-installed

Front rack rail:	14RU
Rear rack rail:	9RU
Dimensions:	21.1"W [53.5 cm] x 21.7"D [55.1 cm] x 28.5"H [72.4 cm]
Shipping weight:	55 lb [25 kg]

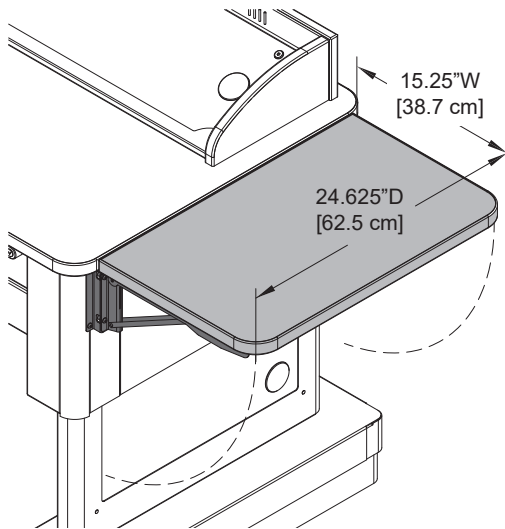

Flip-up Shelf - 55533

- Shelf hinges lock into place in the upright position
- Shelf installs level with worksurface
- Mounts on left or right
- Available in matching, or White Chalk Dry Erase laminate

Dimensions:	15.25"W [38.7 cm] x 24.625"D [62.5 cm] x 1"H [2.54 cm]
Weight capacity:	35 lb [15.9 kg]
Shipping weight:	20 lb [9.1 kg]

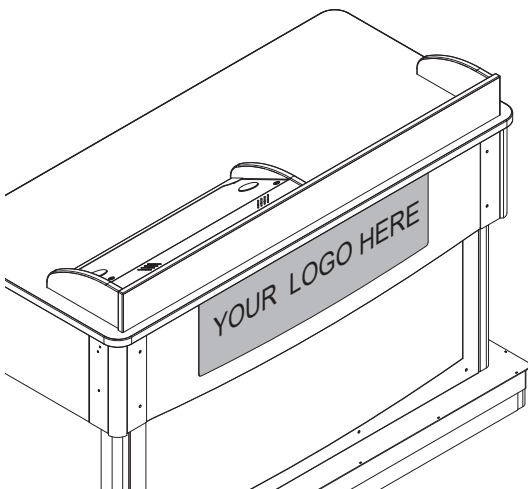

Customized Logo Panel - 55389

- Attaches to audience-side of lectern
- To get panel customized-contact Spectrum for details
- New logos require a first-time logo charge

Dimensions:	35.25"W [89.53 cm] x 9"H [22.86 cm]
Available logo area:	35"W [88.91 cm] x 9"H [22.86 cm]

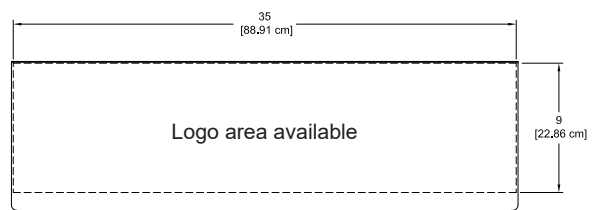

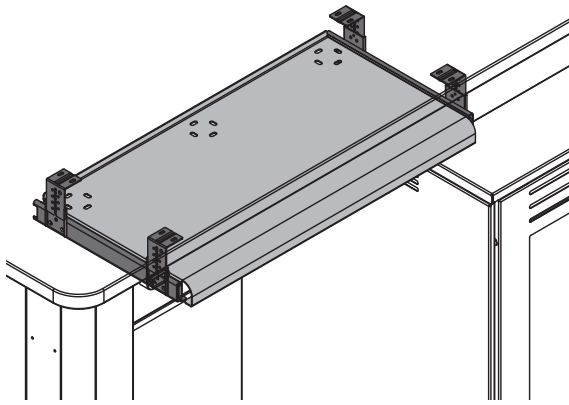

Pull-out Keyboard Tray - 55496

- Installed in left or right position (opposite rack cabinet) using pre-drilled holes
- Tray can be installed and used as a keyboard tray or flipped and used as a storage drawer using pre-drilled mounting holes under the worksurface.
- Wire management slots in tray
- Max 1 tray per Freedom XRS Elite
- 24"W [61 cm] x 11.625"D [29.5 cm] x 2.43"H [6.1 cm]
- 16 ga steel
- Unit weight: 8 lb [3.6 kg]
- Shipping weight: 10 lb [4.5 kg]

Note: The keyboard tray protrudes 3.9" [10 cm] below the worksurface. If the lectern is used for ADA use, a higher adjusted worksurface is necessary to provide ADA leg clearance.

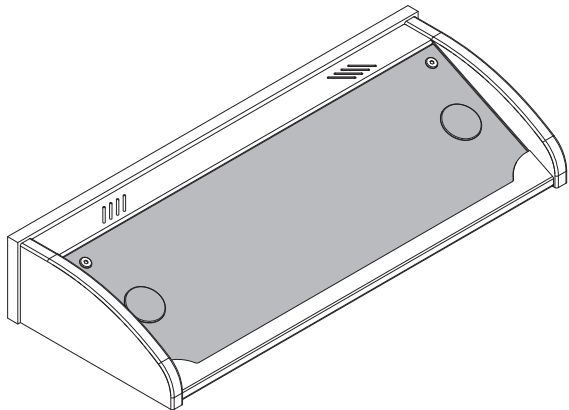

Insert panels are available to customers needing a replacement panel or different cutouts for technology upgrades.

Overbridge Insert Panel-Medium - 96504

- Panel for overbridge version only (overbridge not available separately)
- Contact Spectrum to specify cutout size(s) and position(s)
- Includes two 2" [5.08 cm] grommets with covers
- Customer-installed

Dimensions:	27.25"W [69.2 cm] x 9"D [22.9 cm] x .79"H [2 cm]
Unit weight:	N/A
Shipping weight:	8.5 lb [3.9 kg]

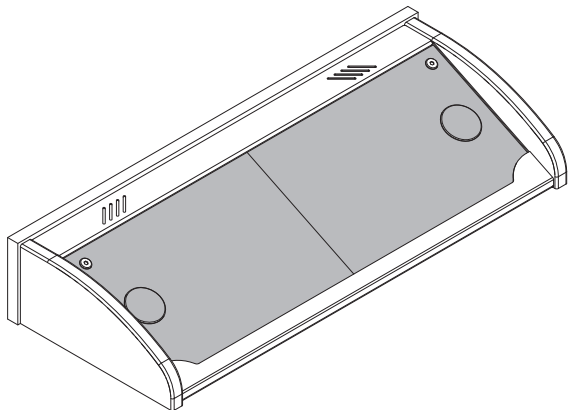

Two-piece Overbridge Insert Panel-Medium - 96512

- Split panel for overbridge version only
- Contact Spectrum to specify cutout size(s) and position(s)
- Includes 2" [5.08 cm] grommets with covers
- Customer-installed

Dimensions:	13.625"W [34.6 cm] x 9"D [22.86 cm] x .79"H [2 cm]
Unit weight:	N/A
Shipping weight:	4.25 lb [1.9 kg]

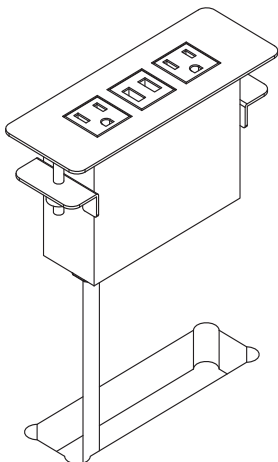

Power Module - 99058

- (2) AC power receptacles
- (2) USB charge ports
- Aluminum housing and flange
- Thumbscrew clamps
- Requires worksurface cutout
- ETL-certified
- Available in black, silver, or white
- Customer-installed



Cutout required:	5.65"W [14.35 cm] x 1.65"D [4.19 cm]
Power cord:	10' [305 cm] 14AWG *3C power cord
Power receptacles:	125V, 60hz, 15A tamper-resistant
USB charging ports:	2.1A (10.5W) (not data-compatible)
Dimensions:	6.38"W [16.2 cm] x 2.36"D [6 cm] x 3.54"H [9 cm]
Unit weight:	2 lb [.9 kg]
Shipping weight:	2.35 lb [1 kg]



Flat Panel Monitor Arm

95512 - for monitors weighing 2-13 lb
95522 - for monitors weighing 7.5-25 lb
95509 - for monitors weighing 12-31 lb

- Six mounting options (clamp, thru-desk, wall, grommet hole, side bolt, reverse wall)
- Compatible with all VESA® monitors - includes 75mm and 100mm VESA® adapters
- Cable management concealed in arm



Dual Flat Panel Monitor Arm - 95533

- Weight range: 3.5-13 lb per monitor
- Six mounting options (clamp, thru-desk, wall, grommet hole, side bolt, reverse wall)
- Compatible with all VESA® monitors - includes 75mm and 100mm VESA® adapters
- Cable management concealed in arm



Heavy-Duty Monitor Arm

95539 - without USB & multimedia ports
95540 - with USB & multimedia ports

- Adjustable gas spring counterbalance
- Weight range: 2.2-33lb
- Fits most 17-35" monitors
- Quick-release 75mm, 100mm, VESA® mounting plate
- Clamp or grommet mounting
- Optional (2) USB 3.0 ports and (2) 3.5mm jacks for mic / headphones
- Cable management channel

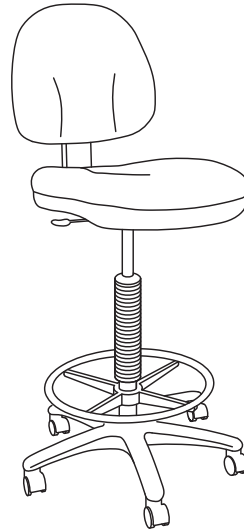

Adjustable Drafting Stool - 38202

- 40-52" height-adjustment via pneumatic cylinder
- 360° swivel
- Tilting backrest
- 18" diameter fixed foot ring
- 5-star base



EM Wireless Charging Pad - 99057

- Uses electromagnetic technology to charge Qi V1.2 compliant IC devices ("Qi" enabled)
- LED to confirm pairing / charging
- Security tab prevents theft
- Requires 3" round cutout to be made by customer
- UL-certified



7-Outlet Power Strip - 99024

- Electrical Rating: AC 125V, 15 Amps
- 1000 Joules surge capacity
- 12' cord length
- LED switch
- UL Listed
- Shipping weight: 1.9 lb [.86 kg]

Note: The unit requires a 7" diameter of clearance to work with Qi-enabled phones placed in any orientation. The 3" dia cutout should be located on the worksurface at least 3.5" from any edge.

Rack-mount Accessories

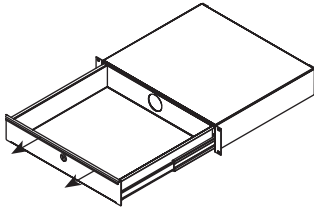

Locking Drawer - 2RU - 97527

- 16ga steel
- Drawer: 15.97"W [40.56 cm] x 14.56"D [36.98 cm] x 3"H [7.63 cm]
- Weight capacity: 50 lb [22.7 kg]
- Shipping weight: 15.85 lb [7.2 kg]

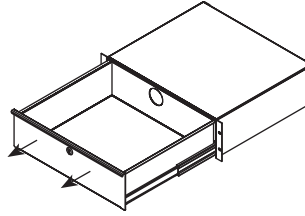

Locking Drawer - 3RU - 97526

- 16ga steel
- Drawer: 15.97"W [40.56 cm] x 14.56"D [36.98 cm] x 5.25"H [13.33 cm]
- Weight capacity: 50 lb [22.7 kg]
- Shipping weight: 18.5 lb [8.4 kg]

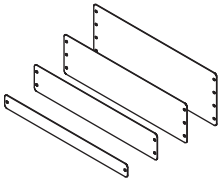

Rack-Mount Blanks

1RU - 97510 3RU - 97512
2RU - 97511 4RU - 97513

- Fills rack spaces where components are not needed
- 16 ga steel
- Shipping weight: <1 lb [.45 kg]

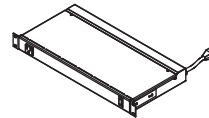

9-Outlet Power Strip - 1RU - 99021



- 8 outlets rear (breaker-protected)
- 1 convenience outlet front
- 115VAC, 60 Hz, 15 amps max
- 9' power cord
- Front LED power switch
- Enhanced surge protection
- ETL-listed, UL-listed
- 19"W [48.27 cm] x 9.25"D [23.5 cm] x 1.74"H [4.41 cm]
- Shipping weight: 8.7 lb [3.9 kg]

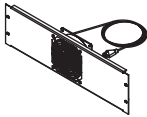

Single Fan - 3RU - 97507

- 50 cfm
- 120V~50/60 Hz, 15/13W
- RoHS
- 19"W [48.27 cm] x 1.56"D [3.97 cm] x 5.25"H [13.33 cm]
- Shipping weight: 3.78 lb [1.7 kg]

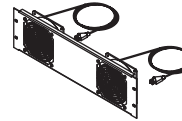

Double Fan - 3RU - 97506

- 100 cfm
- 120V~50/60 Hz, 15/13W
- RoHS
- 19"W [48.27 cm] x 1.56"D [3.97 cm] x 5.25"H [13.33 cm]
- Shipping weight: 5.47 lb [2.5 kg]

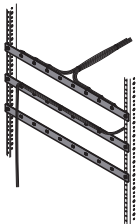

Wire Lace Kit - 95517

- Provides wire management
- Mounts to standard rack rails
- Includes (3) lace straps and mounting screws
- Includes (12) 5.5" zip ties
- Shipping weight: 1.25 lb [.57 kg]

See spectrumfurniture.com for the latest accessories and detailed warranty information.

Warranty

We will make it right for you!

Thanks for choosing Spectrum! Spectrum is committed to provide complete customer satisfaction. Each of our products is manufactured from the best materials available and each product is stringently monitored throughout the production process through our P.A.C.E. program (Product Assurance to meet Customer Expectations).

We expressly warrant that Spectrum products will be of good quality and workmanship and free from defect for the period set out in the warranty from the date of delivery.

For a listing of all product specific warranty terms please visit our website at:

<https://www.spectrumfurniture.com/en/resources/purchasing-terms-warranty>

1-800-235-1262

Toll-free HELPLINE

spectrum@spectrumfurniture.com



Spectrum Industries is Certified ISO 9001:2015