

## Freedom One eLift Lectern™

55542

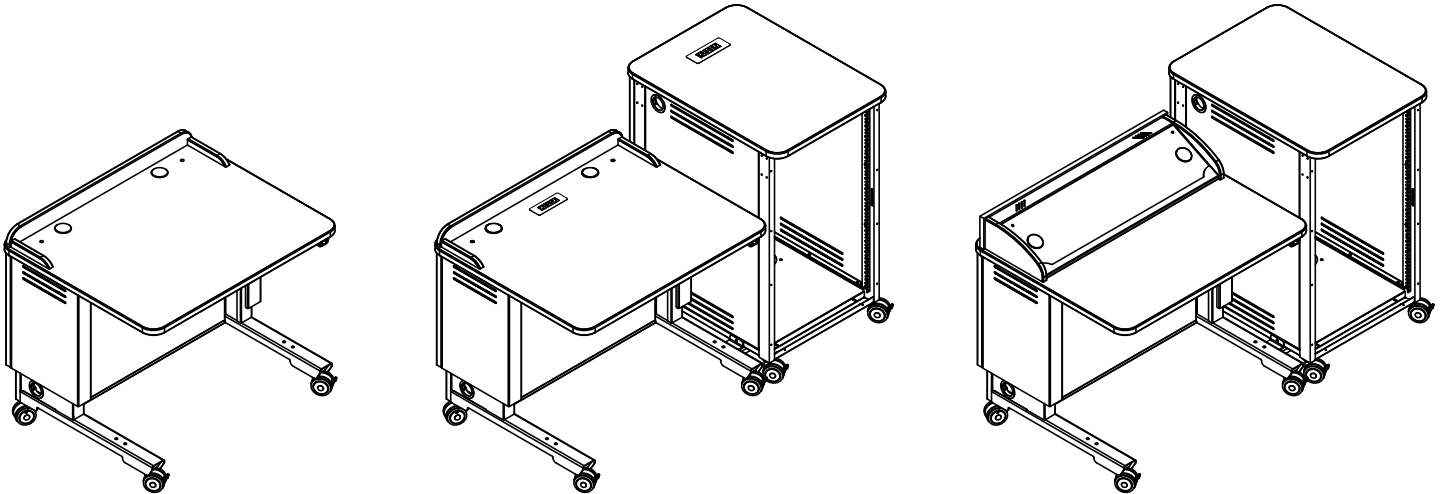

**⚠ Important ⚠**

Before using this product:

- Read this manual
- Comply with all safety and operating instructions
- Ensure all parts and correct quantities are included

Any parts damaged during shipment must be reported within 5 days of receipt. To report information regarding missing parts or damage, to purchase parts or accessories, or if you have any questions, please contact us.

Thank you for purchasing Spectrum products!

**⚠ Important ⚠**

Avant d'utiliser ce produit:

- Veillez à lire ce guide
- Respectez les consignes de sécurité et d'utilisation
- Vérifiez que vous disposez de toutes les pièces nécessaires à l'installation

Les pièces endommagées pendant le transport doivent faire l'objet d'un rapport dans les 5 jours de leur réception. Veuillez prendre contact avec nous si des pièces manquent ou sont abîmées, si vous avez des questions, ou encore pour acheter des pièces ou des accessoires.

Merci pour votre achat d'un produit Spectrum!

**⚠ Importante ⚠**

Antes de utilizar este producto:

- Lea este manual
- Cumpla con todas las instrucciones de prevención de accidentes y operativas
- Revise que todas las partes y las cantidades correctas estén incluidas

Si alguna parte se dañó durante el embarque, deberá reportarla en un lapso de 5 días a partir de la recepción. Para reportar cualquier información sobre partes faltantes o dañadas, para adquirirlas o comprar accesorios, o bien, si tiene alguna duda, póngase en contacto con nosotros.

¡Gracias por adquirir productos Spectrum!

??



<http://www.spectrumfurniture.com>



Owner's Manual  
Le manuel du propriétaire  
El manual del propietario



Specs  
Spécifications  
Especificaciones



Video  
Vidéo  
Vídeo



800-235-1262

## 1. Lectern lift mechanism initial setup, operation, and reset procedure

### Preparation:

- Read all instructions before operation.
- Make sure lectern is plugged-in using the 15-foot, 15-amp power cord.
- Locate the "Up" and "Down" control buttons. Control pad is located on the instructor-side under the worksurface front edge on opposite side from rack cabinet.
- Keep clear of pinch points during worksurface movement.

### Normal Operation:

To raise or lower the lectern, press and hold the "up" or "down" arrow keys on the control pad until the worksurface reaches the desired height. The worksurface can be adjusted from 28.5"H (minimum) to 42"H (maximum).

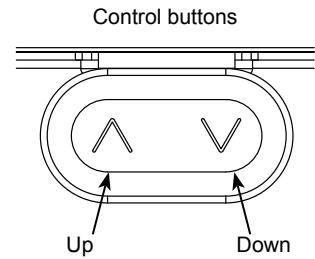

Figure 1.1

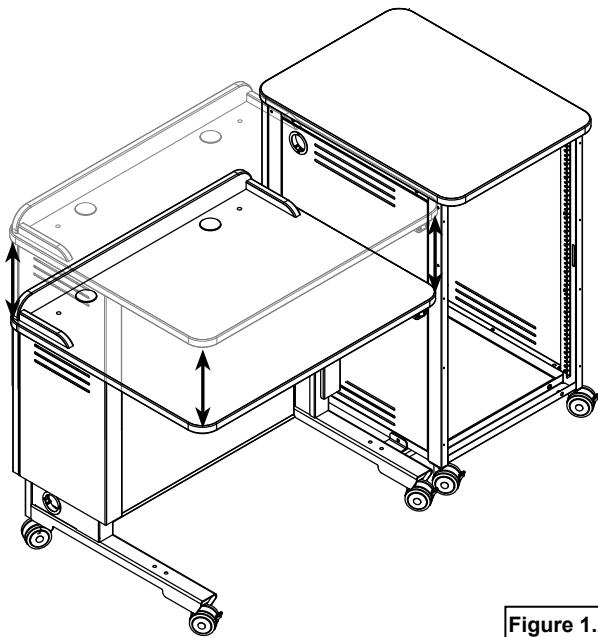

Figure 1.2

### CAUTION

Keep clear of pinch points during worksurface movement. Note: The lift actuators provide a total of 360 lb of lift.

**Always unplug the lectern before working under the worksurface. Do not place anything under the worksurface when operating lift.** Although this lectern utilizes an anti-collision feature that briefly stops and reverses the worksurface motion in the event of an obstruction, use caution when raising or lowering. **Do not** sit at, under, or on the worksurface when operating the lift mechanism and be sure lectern movement does not interfere with objects or people. **Use caution when raising or lowering the worksurface!**

Note: The lectern has a load-sensing, anti-collision feature programmed into the controller that actively locks out the lift mechanisms when unbalanced loads are encountered; i.e. an obstruction under the worksurface, or weight from a person sitting on one side of the lectern.

Note: This unit is not designed for use with cord reels or surface-mount cord reel accessories.

## 2. Attach equipment rack casters / glides

1. On a non-abrasive surface, carefully tip the equipment rack onto its back or side.
2. Install the included stem casters or glides and tighten securely.  
Note: 2 locking casters should be installed on the instructor-side for easy-access.
3. Tip the equipment rack back upright.

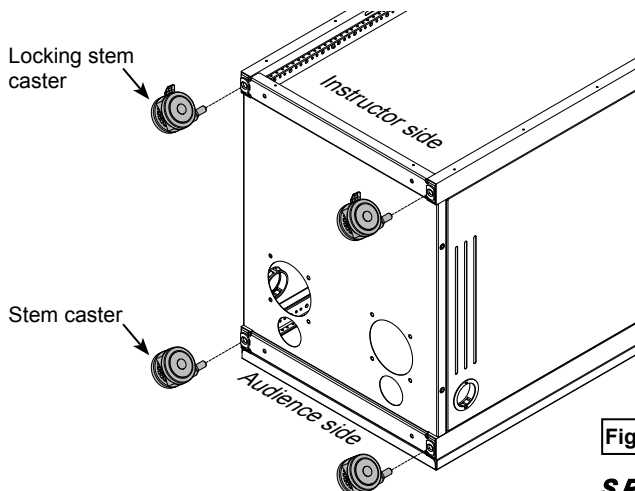
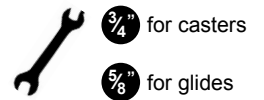

Figure 2.1

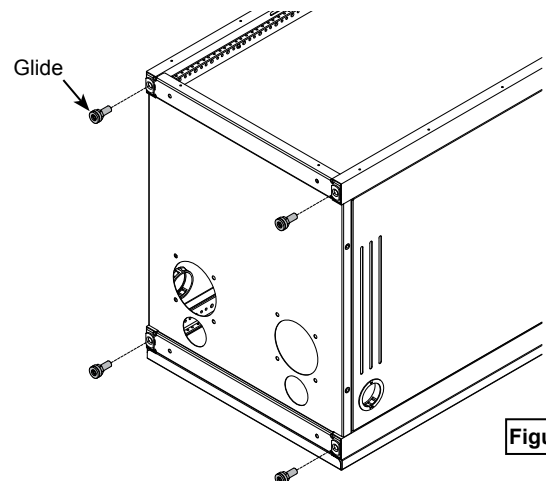
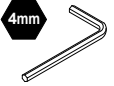
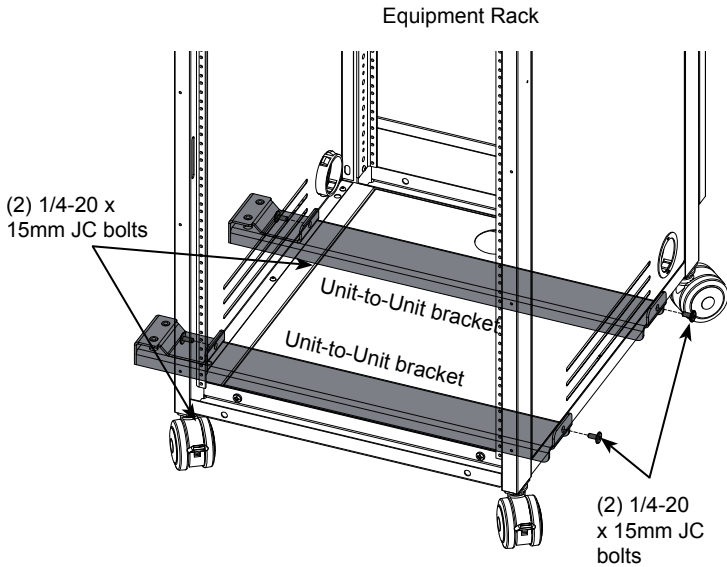

Figure 2.2

### 3. Connect lectern and equipment rack



1. Determine which side of the lectern the equipment rack is to be installed (left or right side). (Right-side installation shown.)
2. Attach the unit-to-unit brackets to the equipment rack side panel mounting holes with (4) 1/4-20 x 15mm JC bolts. **Figure 3.1.**
3. Bring the equipment rack to the lectern and align the unit-to-unit brackets with the mounting holes in the lectern leg.
4. Install (4) 1/4-20 x 40mm JC bolts through the top of the lectern leg and tighten securely. **Figure 3.2.**



**Figure 3.1**

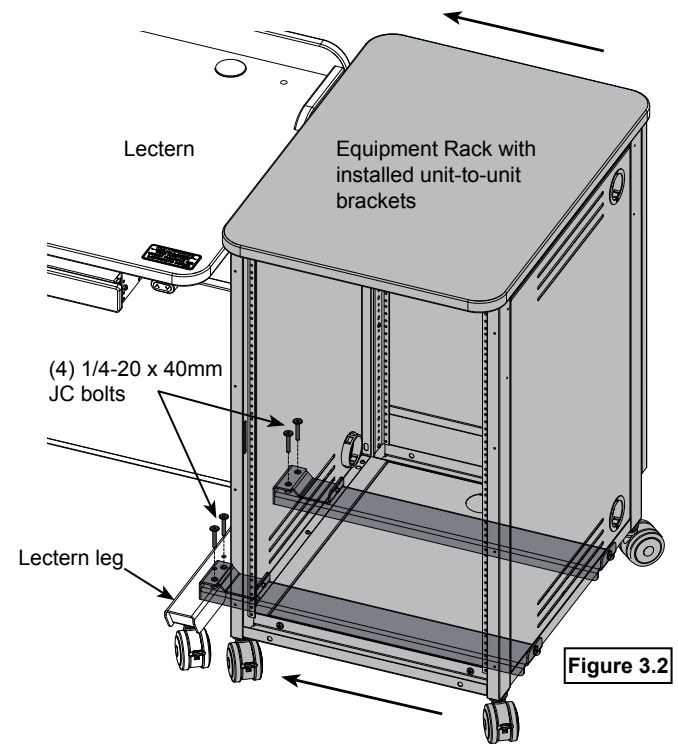

**Figure 3.2**

### Installing flip-up shelf (optional)

1. Determine which side of the equipment rack you want the shelf installed. (Left or right).
2. Extend each shelf bracket by depressing the release lever and lifting until it locks into the 90° position. **Figure 4.1.**
3. Using a second person to support the shelf, install the (8) 8-32 x 1/2" PH thread-cutting screws into the side panel. Do not tighten until all screws have been installed.
4. Tighten all screws securely.
5. Install 2" grommet.

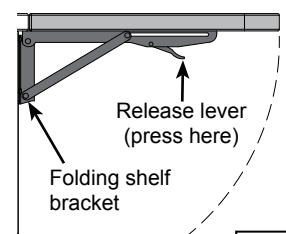

**Figure 4.2**

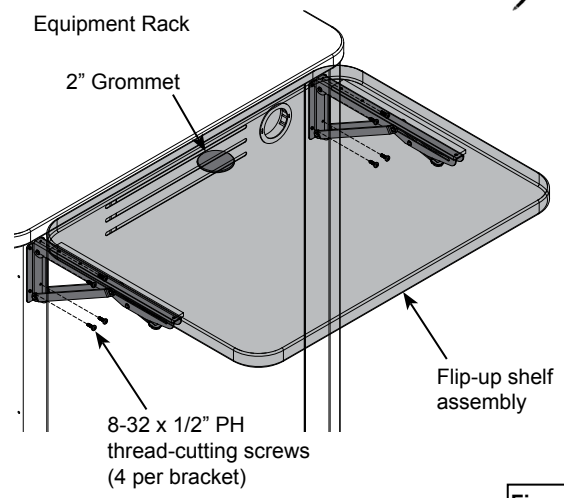

**Figure 4.1**

Note: The flip-up shelf option may not be included with all configurations. The shelf is designed for use on Freedom One eLift equipment racks that are attached to the lectern with unit-to-unit connectors. The shelf installs on the equipment rack side opposite the Freedom One Lectern.

#### Operation

The shelf will automatically lock into place when lifted into the horizontal position with the levers released. **Figure 4.2.** To lower or flip-up the shelf, press and hold the shelf bracket levers while slowly lowering or raising the shelf. Do not move the lectern while the shelf is in the horizontal position.

Note: Power and communication wiring for document cameras, laptop computers, and / or projectors placed on the flip-up shelf should be routed on top of the audience-side of the shelf. Use of the shelf grommet hole for wiring will result in pinching of the cords when the shelf is folded.



Keep clear of pinch points during shelf movement. Do not exceed 35 lb [15.9 kg] of weight on shelf. **Not for use on stand-alone equipment racks.**

## Overbridge insert panel *(select overbridge lecterns)*

1. To remove the overbridge insert panel, remove the (2) 1/4-20 x 35mm JC bolts with a 4mm hex wrench and lift out the panel. **Figure 5.1.**
2. To make cutouts in the insert panel [optional]:
  1. Identify all location(s) and sizes for controller(s) or electronics while making sure all devices fit within the maximum cutout space available in the overbridge panel. See **Figure 5.2, 5.3.**
  2. Locate and mark the exact cutout area(s) on the panel.  
**Note: Using masking tape on cut lines will minimize laminate chipping while cutting.**
  3. Carefully make the cutout(s) in the overbridge panel using a jigsaw or router.
3. Install controller(s) / electronics into panel.
4. Re-install the overbridge panel and secure with (2) 1/4-20 x 35mm JC bolts.

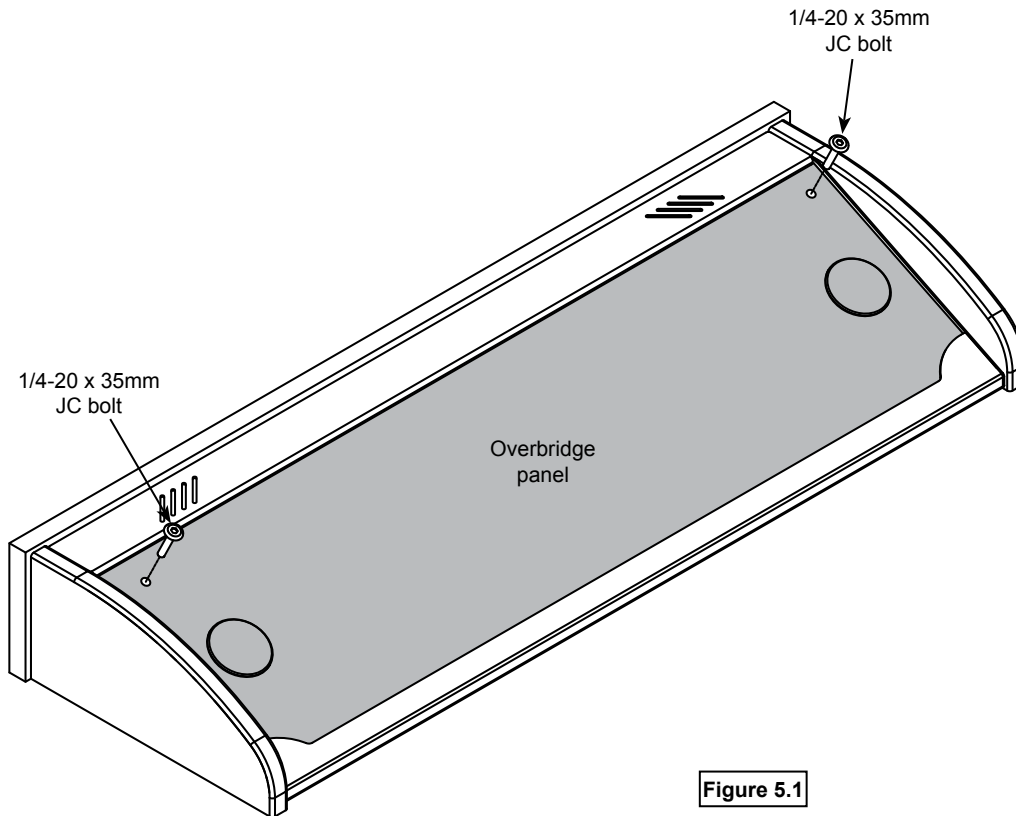
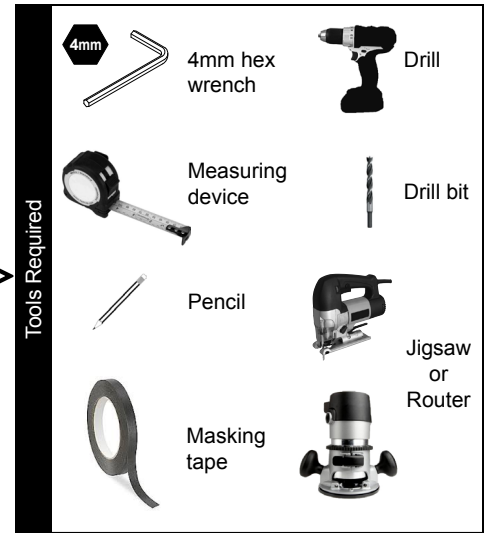

Note: Blank overbridge panels require the customer to make necessary cutouts with a jigsaw or router. This has a moderate difficulty rating, so experience and skill with tools is required.

Freedom One eLift Overbridge Insert Panel Blank  
(flat view)

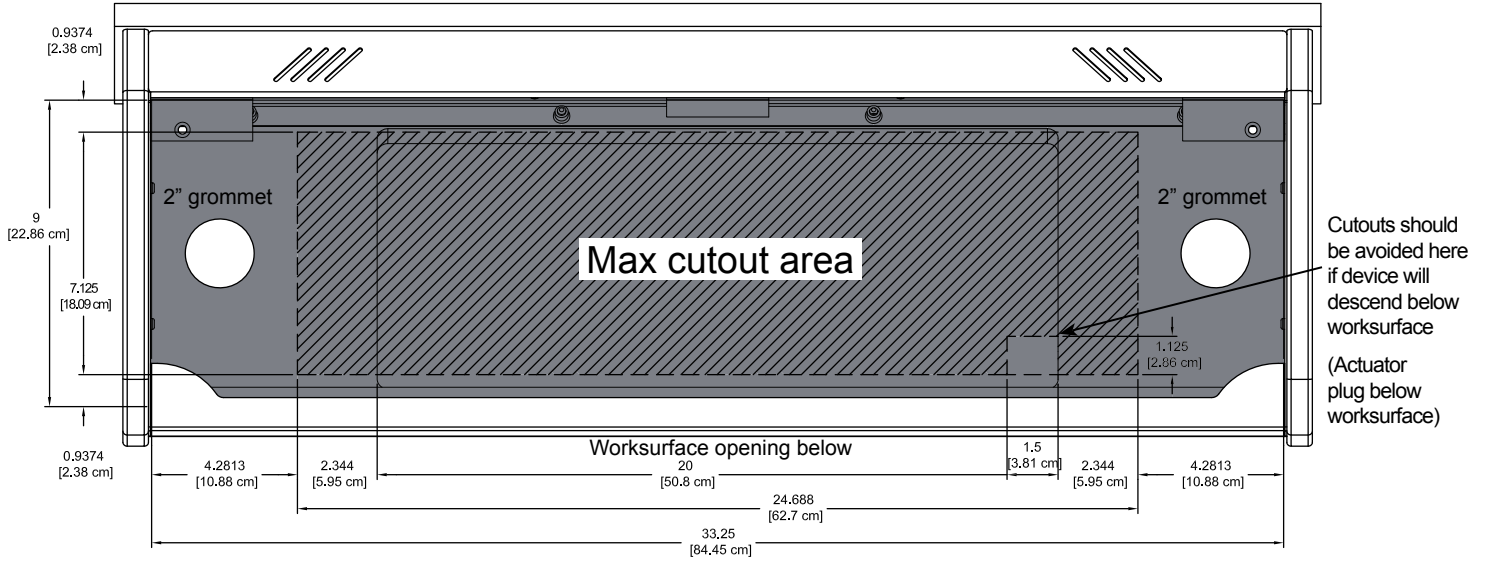

Figure 5.2

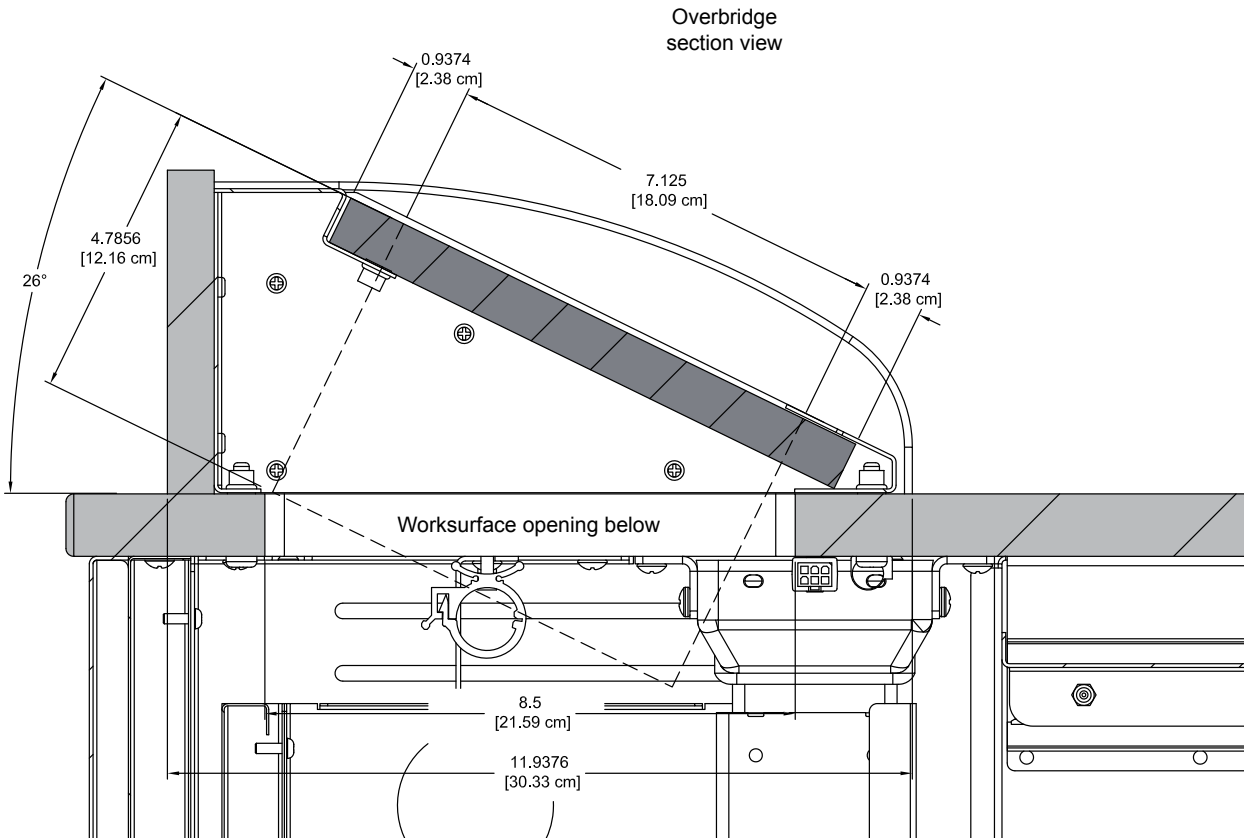

Figure 5.3

## Removing eq. rack audience-side panel

The audience-side panel can be removed to access the rear portion of the equipment rack.

1. To remove the panel, gently pull the top of the panel and lift the panel out and away from the equipment rack. **Figure 6.**
2. To reattach, align the panel with the frame and snap into place.

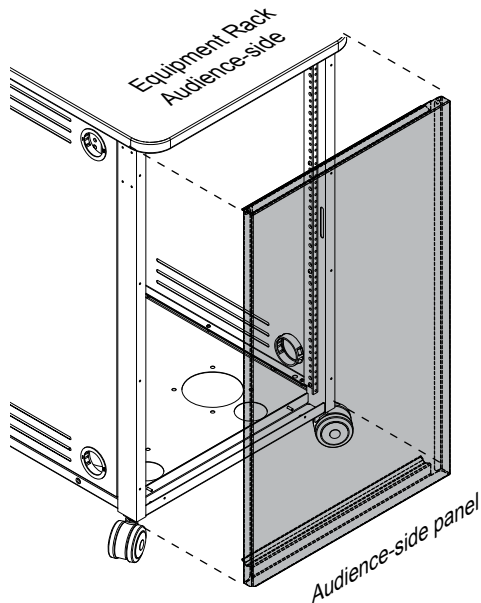

Figure 6

## Moving and parking the lectern

- Before moving, unplug and secure all power cords.
- Close and lock doors.
- Remove any items from the top of the worksurface.
- Unlock the casters.
- Push slowly and carefully. Do not move over uneven or irregular surfaces.
- Do not allow children to move.
- Lock the casters after moving.
- Do not park unit in areas of heavy traffic.
- Do not run power cords across hallways, classrooms, or other areas where they will be walked on.
- Do not leave unit unattended in areas where children have access.
- Keep doors closed and locked whenever unit is unattended or parked.
- Keep casters locked whenever the lectern is unattended.

## Wiring Diagram

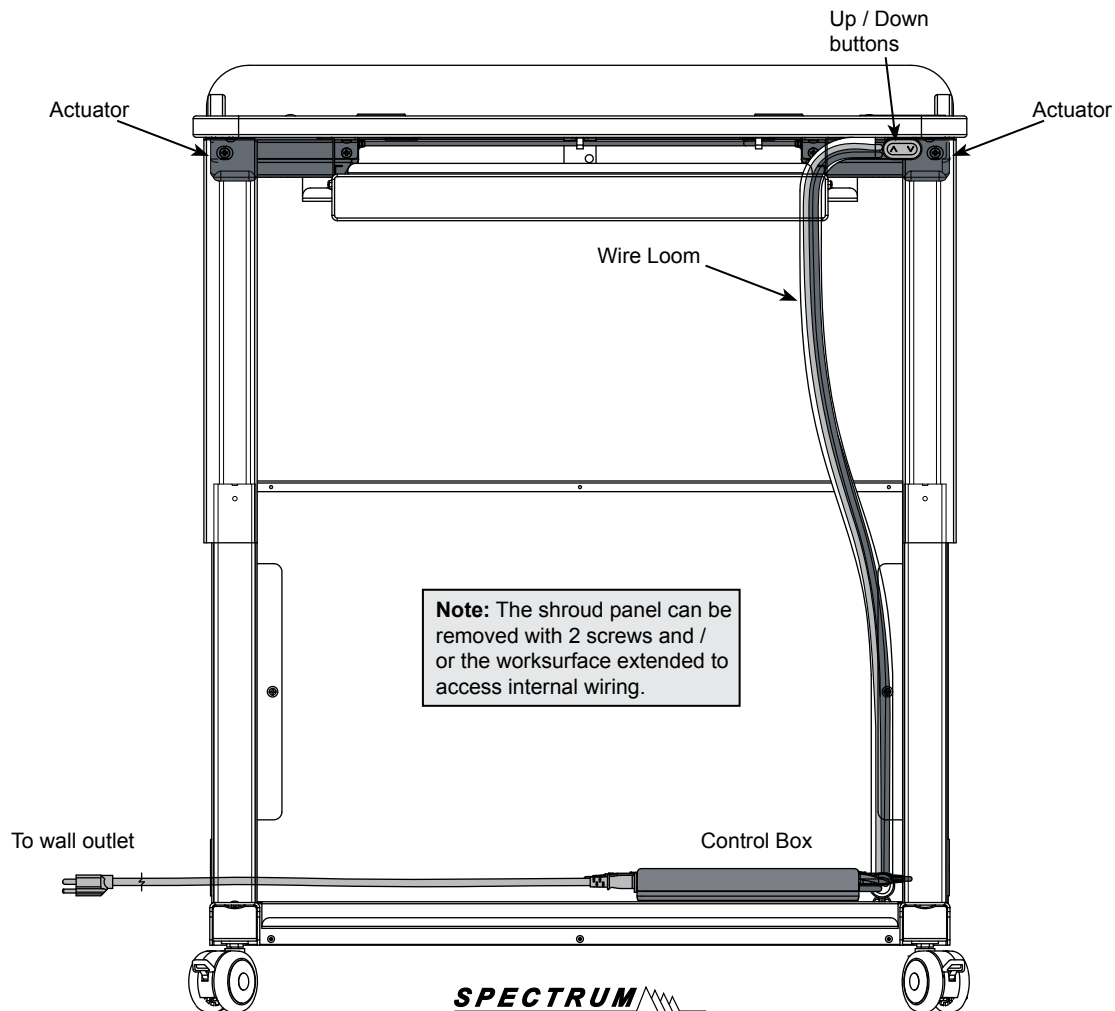
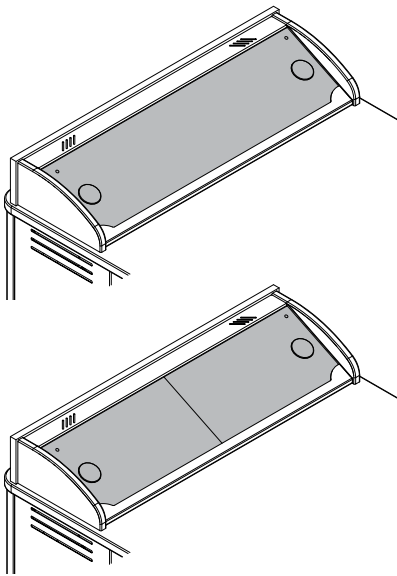

Figure 7



**Overbridge Insert Panel-Large**

**One-piece - 96507**

**Two-piece - 96513**

- Contact Spectrum to specify cutout size(s) and position(s)
- Includes two 2" [5.08 cm] grommets with covers
- Customer-installed

96507 dims:	33.25"W [84.45 cm] x 9"D [22.9 cm] x .79"H [2 cm]
96513 dims:	16.625"W [42.2 cm] x 9"D [22.9 cm] x .79"H [2 cm]
Shipping weight:	8.5 lb [3.9 kg]

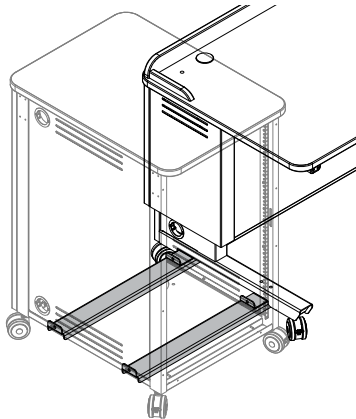

**Unit-to-Unit Connector Kit - 55359**

- For connecting equipment rack to lectern
- Simple installation-lectern and equipment rack can remain right-side up
- Shipping weight: 9 lb [3.9 kg]

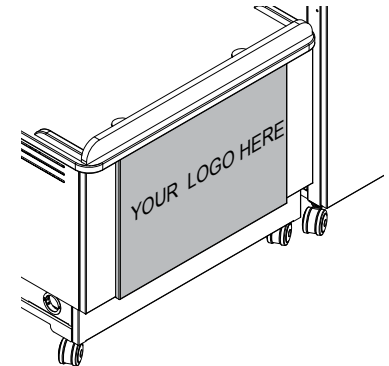

**Customized Logo Panel - 55380**

- To get a customized logo panel, contact Spectrum to specify all logo details
- New logos require a first time logo charge

Dimensions:	26"W [66 cm] x .625"D [1.6 cm] x 19.09"H [48.5 cm]
Shipping weight:	15 lb [6.8 kg]

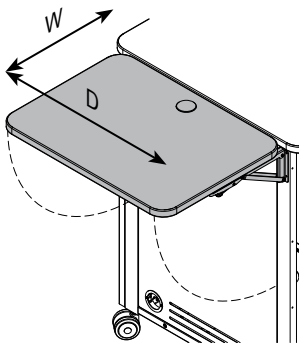

**Flip-up Shelf - 55543**

- Shelf hinges lock into place in the upright position
- Includes 2" grommet
- Mounts on left or right side of equipment rack
- Available in matching, or White Chalk Dry Erase laminate

Dimensions:	19.25"W [48.9 cm] x 26"D [66 cm] x 1"H [2.54 cm]
Weight capacity:	35 lb [15.9 kg]
Shipping weight:	27 lb [12.3 kg]

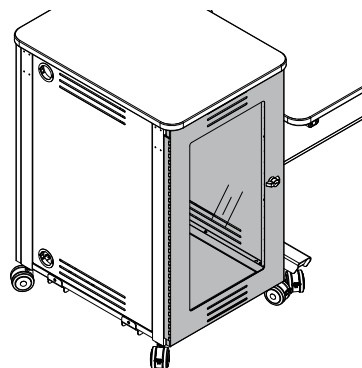

**Clear Acrylic Locking Door**

**39"H - 55512**  
**32"H - 55510**

- For instructor-side installation
- Can be installed hinged from the left or right side
- Shipping weight: 13 lb [5.9 kg] (39"H)  
11.5 lb [5.2 kg] (32"H)

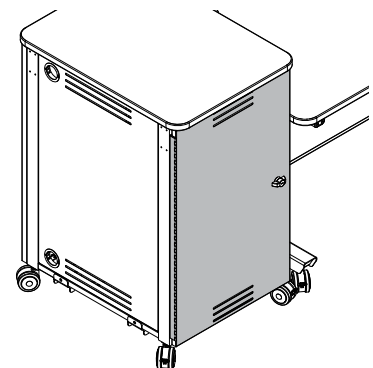

**Solid Locking Door**

**39"H - 55511**  
**32"H - 55509**

- For instructor or audience-side installation
- Can be installed hinged from the left or right side
- Shipping weight: 13 lb [5.9 kg] (39"H)  
11.5 lb [5.2 kg] (32"H)

Note: When used on the audience-side of the equipment rack, the door will replace the standard audience-side panel.

 Flip-up shelf not for use on stand-alone equipment racks.



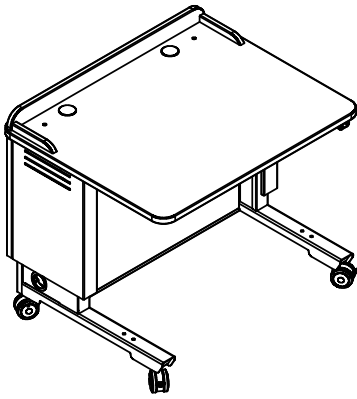

**Freedom One eLift Lectern - 55542**

- Electrically-adjustable worksurface
- ADA-compliant
- Available in surround or overbridge versions
- Factory-assembled with casters or glides

Lectern Style:	• Surround • Overbridge
Worksurface options:	• No Cutouts • Custom Cutouts
Base options:	• Twin Wheel Casters • Glides
Shipping weight: (nominal)	151 lb [68.6 kg]

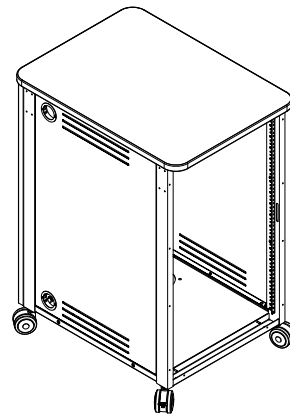

**Equipment Rack for Freedom One eLift - 55508**

- 39"H (18RU) or 32"H (14RU)
- Front and rear rack rails
- Standard audience-side panel included
- Casters / glides assembled by customer
- 39"H [99.3 cm] or 32"H [81.3 cm] worksurface height (with casters)
- Two 2" grommets in each side panel provide cord access
- Up to two equipment racks can be attached to the lectern (1 on left and 1 on right)

Worksurface options:	• No Cutouts • Custom Cutouts • Power Module
Base options:	• Twin Wheel Casters • Glides
Door options:	• Solid door • Acrylic door
Shipping weight: (nominal)	• 116 lb [52.7 kg] (39"H) • 102 lb [46.3 kg] (32"H)

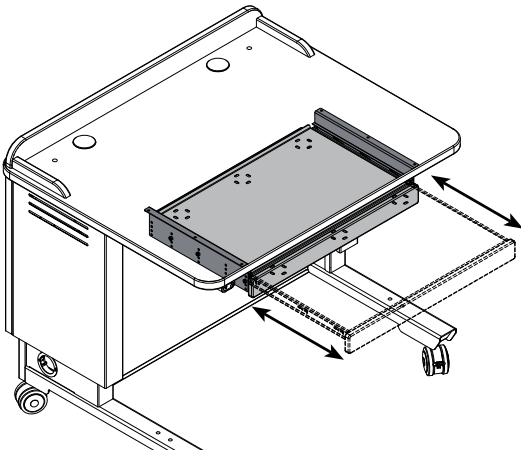

**Keyboard Tray - 55379**

- Tray can be installed and used as a keyboard tray or flipped and used as a storage drawer using pre-drilled mounting holes under the lectern worksurface.
- Wire management slots in tray

Dimensions:	22"W [55.9 cm] x 13.815"D [35.1 cm] x 4"H [10.2 cm]
Weight capacity:	25 lb [11.4 kg]
Shipping weight:	14 lb [5.4 kg]

Note: The keyboard tray protrudes 3.4375" [8.73 cm] below the work-surface. If the lectern is used for ADA use, a higher adjusted worksurface (around 32"H) is necessary to provide wheelchair clearance.

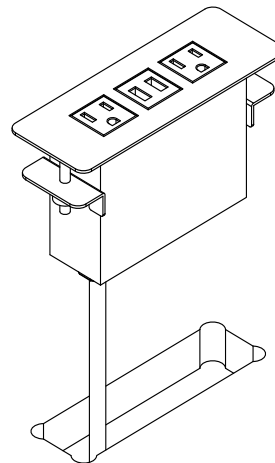

**Power Module - 99058**

- (2) AC power receptacles
- (2) USB charge ports
- Aluminum housing and flange
- Thumbscrew clamps
- Requires worksurface cutout
- ETL-certified
- Available in black, silver, or white
- Customer-installed

Cutout required:	5.65"W [14.35 cm] x 1.65"D [4.19 cm]
Power cord:	9' [274 cm] 14AWG *3C power cord
Power receptacles:	125V, 60hz, 15A tamper-resistant
USB charging ports:	2.1A (10.5W) (not data-compatible)
Dimensions:	6.38"W [16.2 cm] x 2.36"D [6 cm] x 3.54"H [9 cm]
Unit weight:	2 lb [.9 kg]
Shipping weight:	2.35 lb [1 kg]





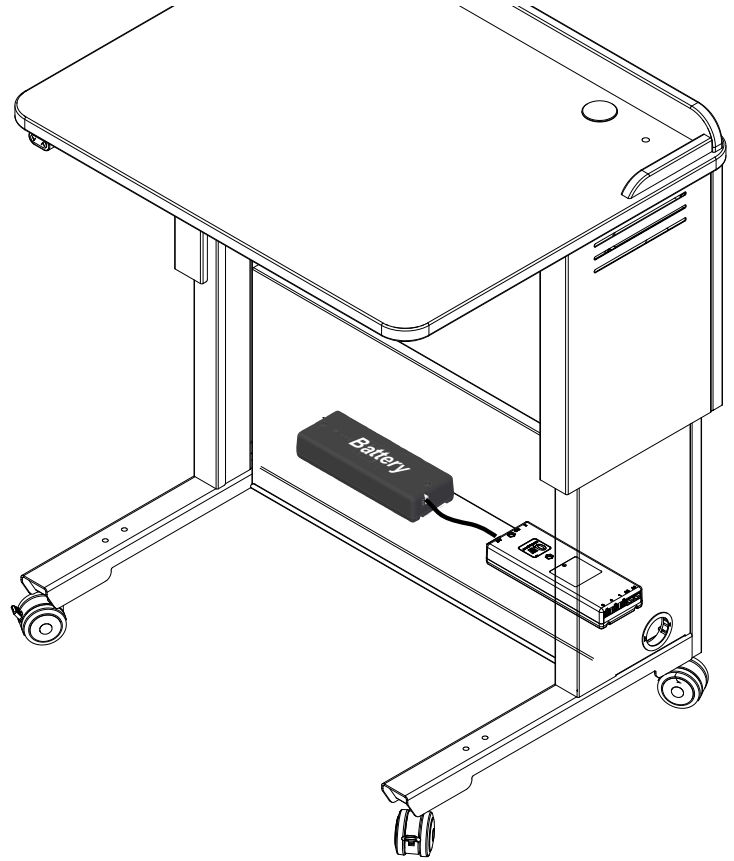

### Rechargeable Battery Pack System - 99045

- Creates a mobile lectern / desk by providing the ability to operate the unit in locations without AC power
- Compact, lightweight lithium-ion battery plugs into and charges from the existing lectern control box
- On-board LED light bars indicate charge capacity level
- Audio alarm signals when charging is needed
- Thermal switch protection, overcurrent protection
- Easy customer-installation

Battery Type	Lithium-ion
Capacity	2.2 Ah / 53 Wh
Voltage (nominal)	24V
Discharge current	9A (max)
Max charging voltage	40V DC
Charging current	0.5 A
Certifications	EN 62133 (Battery safety testing) UL 1642 (Lithium cells, standard test) UN 38.3 (Transportation of Lithium batteries) UL 2054 (Household and commercial batteries) EN 60335-1 with CBH Advanced
Unit weight: (nominal)	1.32 lb [.6 kg]
Shipping weight: (nominal)	2 lb [.9 kg]

#### Battery / Control Box Compatibility:

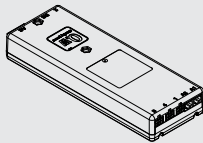

The CBD6S Linak control box is compatible with this battery pack.



Older CBD4 Linak control boxes are not compatible with this battery pack.

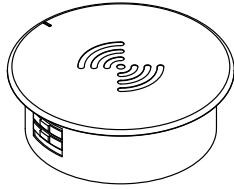

### EM Wireless Charging Pad - 99057

- Uses electromagnetic technology to charge Qi V1.2 compliant IC devices ("Qi" enabled)
- LED to confirm pairing / charging
- Security tab prevents theft
- Requires 3" round cutout to be made by customer
- UL-certified

Note: The unit requires a 7" diameter of clearance to work with Qi-enabled phones placed in any orientation. The 3" dia cutout should be located on the worksurface at least 3.5" from any edge.

Cutout required:	3" dia (by customer)
Input:	DC 5V (with included DC5V.2A power adapter)
Output:	5W max (with included DC5V.2A power adapter)
Power cord:	8' [244 cm] with DC jack
Dimensions:	3.5" dia [8.9 cm] x 1.125"H [2.9 cm]
Shipping weight:	1 lb [.45 kg]



### Flat Panel Monitor Arm

- 95512** - "Light-Duty" for monitors weighing 2-13 lb [.9-5.9 kg]
- 95522** - "Medium-Duty" for monitors weighing 7.5-25 lb [2.5-11.4 kg]
- 95509** - "Heavy-Duty" for monitors weighing 12-31 lb [5.4-14 kg]

- Six mounting options (clamp, thru-desk, wall, grommet hole, side bolt, reverse wall)
- Compatible with all VESA® monitors – includes 75mm and 100mm VESA® adapters
- Cable management concealed in arm



### Dual Flat Panel Monitor Arm - 95533

- Weight range: 3.5-13 lb [1.6-5.9 kg] per monitor
- Six mounting options (clamp, thru-desk, wall, grommet hole, side bolt, reverse wall)
- Compatible with all VESA® monitors – includes 75mm and 100mm VESA® adapters
- Cable management concealed in arm

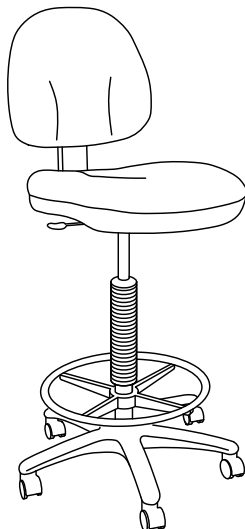

### Adjustable Drafting Stool - 38202

- 40-52" height-adjustment via pneumatic cylinder
- 360° swivel
- Tilting backrest
- 18" diameter fixed foot ring
- 5-star base

# Rack-mount Accessories

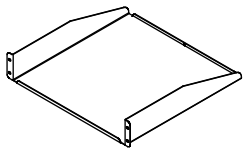

## Cantilever Shelf - 2RU - 97504

- 16ga steel
- Shelf: 17.5"W [44.45 cm] x 18"D [45.7 cm] x 3.5"H [8.89 cm]
- Weight capacity: 50 lb [22.7 kg]
- Shipping weight: 8.1 lb [3.7 kg]

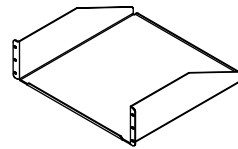

## Cantilever Shelf - 3RU - 97502

- 16ga steel
- Shelf: 17.5"W [44.45 cm] x 18"D [45.7 cm] x 5.25"H [13.33 cm]
- Weight capacity: 80 lb [36.3 kg]
- Shipping weight: 9.2 lb [4.2 kg]

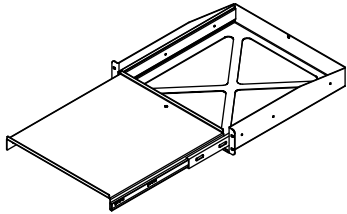

## Pull-Out Shelf - 2RU - 97505

- 16ga steel
- 17.09"W [43.42 cm] x 18.12"D [46.03 cm] x 3.5"H [8.89 cm]
- Weight capacity: 50 lb [22.7 kg]
- Shipping weight: 15.6 lb [7.1 kg]

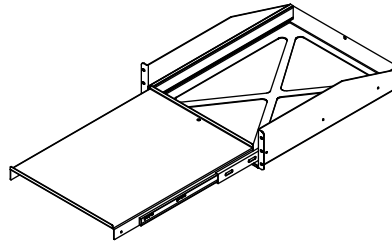

## Pull-Out Shelf - 3RU - 97503

- 16ga steel
- 17.09"W [43.42 cm] x 22.11"D [56.14 cm] x 5.25"H [13.33 cm]
- Weight capacity: 80 lb [36.3 kg]
- Shipping weight: 18.5 lb [8.4 kg]

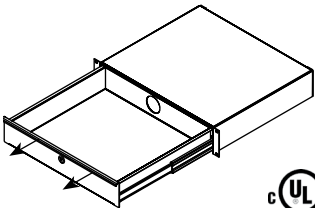

## Locking Drawer - 2RU - 97523

- 16ga steel
- Drawer: 15.97"W [40.56 cm] x 14.56"D [36.98 cm] x 3"H [7.63 cm]
- Weight capacity: 50 lb [22.7 kg]
- Shipping weight: 15.85 lb [7.2 kg]

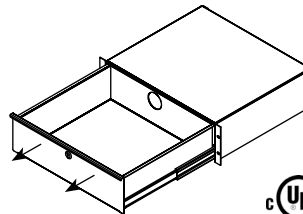

## Locking Drawer - 3RU - 97522

- 16ga steel
- Drawer: 15.97"W [40.56 cm] x 14.56"D [36.98 cm] x 5.25"H [13.33 cm]
- Weight capacity: 50 lb [22.7 kg]
- Shipping weight: 18.5 lb [8.4 kg]

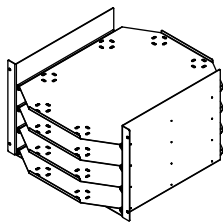

## LT-4 Laptop Storage Unit - 7RU - 97517

- Holds four full-size laptops
- 16ga & 20ga steel
- 18.75"W [47.94 cm] x 20.5"D [52.11 cm] x 12.25"H [31.11 cm]
- Shipping weight: 30 lb [13.6 kg]

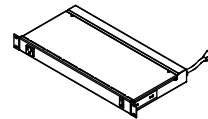

## 9-Outlet Power Strip - 1RU - 99021

- 8 outlets rear (breaker-protected)
- 1 convenience outlet front
- 115VAC, 60 Hz, 15 amps max
- 9' power cord
- Front LED power switch
- Enhanced surge protection
- ETL-listed, UL-listed
- 19"W [48.27 cm] x 9.25"D [23.5 cm] x 1.74"H [4.41 cm]
- Shipping weight: 8.7 lb [3.9 kg]

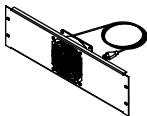

## Single Fan - 3RU - 97507

- 50 cfm
- 120V~50/60 Hz, 15/13W
- RoHS
- 19"W [48.27 cm] x 1.56"D [3.97 cm] x 5.25"H [13.33 cm]
- Shipping weight: 3.78 lb [1.7 kg]

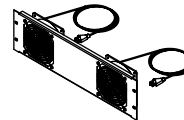

## Double Fan - 3RU - 97506

- 100 cfm
- 120V~50/60 Hz, 15/13W
- RoHS
- 19"W [48.27 cm] x 1.56"D [3.97 cm] x 5.25"H [13.33 cm]
- Shipping weight: 5.47 lb [2.5 kg]

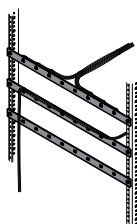

## Wire Lace Kit - 95517

- Provides wire management
- Mounts to standard rack rails
- Includes (3) lace straps and mounting screws
- Includes (12) 5.5" zip ties
- Shipping weight: 1.25 lb [57 kg]

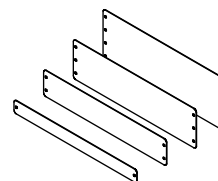

## Rack-Mount Blanks

**1RU - 97510      3RU - 97512**  
**2RU - 97511      4RU - 97513**

- Fills rack spaces where components are not needed
- 16 ga steel
- Shipping weight: <1 lb [45 kg]

# Electric actuator information

## Warning!

Failure to comply with these instructions may result in accidents involving serious personal injury. Failing to follow these instructions can result in the product being damaged or being destroyed.

## Safety Information

### General

Safe use of the system is possible only when the operating instructions are read completely and the instructions contained are strictly observed. Failure to comply with instructions marked with the "NOTE" symbol may result in serious damage to the system or one of its components.

- It is important for everyone who is to connect, install, or use the systems to have the necessary information and access to this User Manual. Follow the instructions for mounting – risk of injury if these instructions are not followed.
- The appliance is not intended for use by young children or infirm persons without supervision.
- If there is visible damage on the product it must not be installed.
- Note that during construction of applications, in which the actuator is to be fitted, there must be no possibility of personal injury, for example the squeezing of fingers or arms.

 **Assure free space for movement of application in both directions to avoid blockade.**

### Before installation, re-installation, or troubleshooting:

- Stop the DL5/DL6
- Pull out the mains plug.
- Relieve the DL5/DL6 of any loads, which may be released during the work.

### Before start-up:

- Make sure that the system has been installed as instructed in this User Manual.
- Make sure that the voltage of the control box is correct before the system is connected to the mains.
- System connection. The individual parts must be connected before the control box is connected to the mains. See the User Manual for LINAK actuators, if necessary.

### During operation

- If the control box makes unusual noise or smells, switch off the mains voltage immediately.
- Take care that the cables are not damaged.
- Unplug the mains cable on mobile equipment before it is moved.
- The products must only be used in an environment, that corresponds to their IP protection.

### Misc.

The actuator system has a sound level below 55dB(A) in typical applications.

Updated manuals and declarations can always be found here:  
[www.linak.com/desklina](http://www.linak.com/desklina)

Label for DL6



**SPECTRUM**  
INDUSTRIES INC.

## Only for EU markets

- This appliance can be used by children aged from 8 years and above and persons with reduced physical, sensory or mental capabilities or lack of experience and knowledge if they have given supervision or instruction concerning use of the appliance in a safe way and understand the hazards involved.
- Children shall not play with the appliance. Cleaning and user maintenance shall not be made by children without supervision.

## Only for Non-EU markets

- Persons who do not have the necessary experience or knowledge of the product/products must not use the product/products. Besides, persons with reduced physical, sensory or mental abilities must not use the product/products, unless they are under surveillance or they have been thoroughly instructed in the use of the apparatus by a person who is responsible for the safety of these persons.
- Moreover, children must be under surveillance to ensure that they do not play with the product.

### Misuse

- Do not overload the actuators – this can cause danger of personal injury and damage to the system.
- Do not use the actuator system for lifting persons. Do not sit or stand on a table while operating – risk of personal injury.
- Do not use the system in environments other than the intended indoor use.

### Repairs

In order to avoid the risk of malfunction, all DESKLINE® repairs must only be carried out by authorised LINAK workshops or repairers, as special tools must be used and special gaskets must be fitted. Lifting units under warranty must also be returned to authorised LINAK workshops.

 **Warning!** If any of the DESKLINE® products are opened, there will be a risk of subsequent malfunction.

 **Warning!** The DESKLINE® systems do not withstand cutting oil.



C/N 120690  
 C/N 9901916  
 C/N 4008003  
 C/N 4008004  
 C/N 4008005  
 C/N 4008671  
 C/N 4009507

**Note:** Use the included control box only-do not connect other control boxes to this product.

Label for CBD6S 200W (SMPS)



### Misc. on the DESKLINE® DL5/DL6 system

This system is a DESKLINE system developed for desks and for indoor use in offices. Do not use it in industrial kitchens or in other environments that have to be cleaned with aggressive detergents. Do not bolt the legs to the floor so that free movement is prevented. This could cause serious damage to the legs in fault situations.

### Warranty - 60 months on DESKLINE® (NEW)

This will be valid for all DESKLINE products produced after the 1st of May 2015.

Products produced before 1st of May 2015 will still be covered by 36 months.

Products used in DESKLINE application: If these products are used in another application, they will be covered by 18 months warranty.

If there is any doubt that returned products are within the warranty period it is to be treated as if they are covered by the warranty. We recommend that you use the date of the control box or actuator as reference if possible. We will have our purchase number printed on the label.

### Maintenance

Clean dust and dirt on the outside of the system at appropriate intervals and inspect them for damage and breaks. Inspect the connections, cables, and plugs and check for correct functioning as well as fixing points.

### Service of double-insulated products:



Class II

A Class II or **double insulated** electrical appliance is one which has been designed in such a way that it does not require a safety connection to electrical earth (US: ground).

The basic requirement is that no single failure can result in dangerous voltage becoming exposed so that it might cause an electric shock and that this is achieved without relying on an earthed metal casing. This is usually achieved at least in part by having two layers of insulating material surrounding live parts or by using reinforced insulation.

There is no earthing / grounding means provided on the product, and no earthing/grounding means is to be added to the product.

In Europe, a double insulated appliance must be labelled "Class II", "double insulated" or bear the double insulation symbol (a square inside another square).

Servicing a double-insulated product requires extreme care and knowledge of the system, and is to be done only by qualified service personnel. Replacement parts for a double-insulated product must be identical to the parts they replace.

 **The cleaners and disinfectants must not be highly alkaline or acidic (pH value 6-8).**

### Description of the DESKLINE® DL5/DL6 system

Each DESKLINE® DL5/DL6 lifting units is equipped with a motor and parallel / memory drive is ensured by means of software in the CBD6S (SMPS) that also takes account of oblique load on the desk. Soft start and stop are also part of this software, which ensures a soft start and stop when adjusting the desk.

### Application of the DESKLINE® DL5/DL6 system:

Irrespective of the load the **duty cycle 10% ~ 6 min./ hour or max. 2 min. at continuous use** stated in the data sheets, must **NOT** be exceeded as this will result in a superheating of the motor, the brake and the spindle nut. Exceeding the duty cycle will result in a dramatic reduction of the life of the system.

The DESKLINE® DL5/DL6 system range contains the following products:

- 1 control box CBD6S 200W or CBD6S 300W (SMPS - Switch Mode Power Supply)
- 1 single DL5/DL6 or 2 in parallel
- 1 exchangeable mains cable
- 1 or 2 motor cables
- 1 DP1U/DPF1M (if memory function is required) DP1C/DPT/DPF1C (if memory function and display is required) or DPF1D (if display is required).

### Electrical connection of the DL5/DL6 system

The DESKLINE® DL5/DL6 system is to be connected as shown in Figure 4. Each DL5/DL6 is to be connected to the sockets on the control box by means of the motor cables, which have a 6-pin plug on each end. Finally, the main power cable is to be mounted and power switched on.

 Please note that the control box must only be connected to the voltage stated on the label.

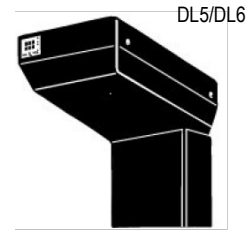

Figure 4

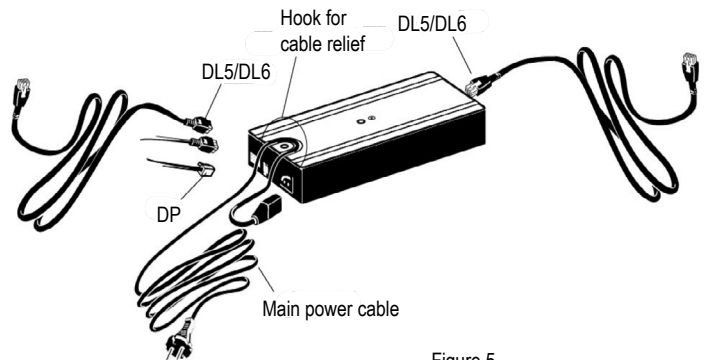

Figure 5

### Method of operation

When the DL/DB's are running, the CBD6S (SMPS) monitors the current consumption on each channel using a special algorithm. If the current consumption on one channel is increased more than a predefined slope, a collision is assumed and all channels are stopped immediately and all DL/DB's will start to run in the opposite direction (approx. 50 mm). This return drive is done automatically and continues with or without any control key pressed (for max. 2.5 sec.).

The anti-collision sensitivity is different in upward and downward direction. Upwards the force is approx. 20 kg. Downwards the load will be approx. 40 kg + the load on the DL/DB (the desk + what is on top of the desk). The 40 kg are needed to activate the anti-collision function.

### Situations where the anti-collision does not work

There are situations where the anti-collision will not be activated. These situations are:

- If the collision happens during the initialisation phase
- If the collision happens within the first 1000 msec or after the control button has been released
- If the collision happens between the floor and the table and the load on the desk + the weight of the legs are lower than 40 kg
- If the collision happens over too long time, e.g. if the collision is with a soft object.

# Freedom One eLift Lectern Troubleshooting Guide

Symptom	Problem	Solution	
Worksurface will not operate	Loss of power	Be sure control box is plugged into a live circuit.	
	Loose electrical connections	Make sure all electrical connections are securely plugged into the control box. See wiring diagram on p.10 for reference.	
	Object encountered under the lectern worksurface	<ol style="list-style-type: none"> <li>1. Raise the worksurface by pressing the "up" button.</li> <li>2. Remove any items under the lectern worksurface.</li> <li>3. Reset the lift mechanism (see below for procedure.)</li> </ol>	
	Misaligned actuators due to unbalanced loads	<b><u>Solution #1</u></b>	
		<ol style="list-style-type: none"> <li>1. Unplug, then re-plug the power cord into a wall outlet.</li> <li>2. Make sure all lift mechanism wire connections are in place and secure.</li> <li>3. Remove <u>anything</u> located under the worksurface.</li> <li>4. Press and hold the "Down" button to lower the worksurface to the lowest "work" position until it stops moving.</li> <li>5. Release the "Down" button.</li> <li>6. Press and hold the "Down" button for 30 seconds. The worksurface will lower, bottom-out, slightly rises, then stop moving. The worksurface must be completely lowered before resuming operation.</li> </ol> <p><b>Note: If the worksurface does not lower when doing this step, release the "Down" button, and retry step 6.</b></p> <ol style="list-style-type: none"> <li>7. Release the "Down" button. The lift mechanism has now been reset and the worksurface can be adjusted normally.</li> </ol>	
<b><u>Solution #2</u></b>		<ol style="list-style-type: none"> <li>1. Detach <u>one</u> of the actuators from the worksurface.</li> <li>2. Lower the lectern all the way down.</li> <li>3. Re-attach the actuator to the worksurface.</li> </ol>	

⚠ WARNING ⚠

Be sure the lectern movement does not interfere with objects or people. Do not place any items under the lectern worksurface.

Note: Not designed to be permanently anchored to the floor. Optional glides are available if a stationary lectern is needed.





## Important Safety and Care Instructions



- Read these instructions before assembly or operation.
- Do not allow children to move the lectern.
- Proceed slowly and carefully when moving the lectern.
- For indoor use only. Do not install or store the lectern where it will be exposed to moisture.
- Do not block the ventilation openings.
- Avoid uneven loading of the equipment into the lectern. Uneven weight distribution could cause the lectern to tip when the lectern is moving.
- Do not allow anyone to sit, stand, or climb on the lectern.
- Use a damp, soft-cloth, or sponge, with mild soap or detergent solution to clean dirty surfaces. Do not use harsh solvents or abrasives.
- This lectern is intended for institutional use. It does not have any user-serviceable parts or user-maintenance requirements. If servicing is necessary, please contact Spectrum Industries for assistance.

### Electrical Safety:

- Do not plug the power cord into an extension cord.
- Inspect power cords for damage before each use. Do not use power cords that are damaged.
- Unplug power cord from electrical outlet by gripping the cord. Do not unplug the power cord by pulling only on the cord.
- Do not step on, drive over, drag, or place objects on the power cord.
- For added safety, plug the lectern into a grounded outlet controlled by a GFI (Ground Fault Interrupter) circuit breaker.
- Electrical devices are not toys. Children are often unaware of the hazards associated with electrical devices. This lectern must always be used by adults or with adult supervision.

**Warning** - Relocating audio and/or video equipment to furniture not specifically designed to support audio and/or video equipment may result in death or serious injury due to the furnishing collapsing or over turning onto a child.

**Warning** - Death or serious injury may occur when children climb on audio and/or video equipment furniture. A remote control or toys placed on the furnishing may encourage a child to climb on the furnishing and as a result the furnishing may tip over on to the child.



## Consignes importantes de sécurité et d'entretien



- Lire ce guide d'utilisation avant l'assemblage ou l'utilisation.
- Interdire aux enfants de déplacer le lutrin.
- Déplacer le lutrin lentement et prudemment.
- Utilisation à l'intérieur uniquement. Ne pas assembler et ne pas ranger le lutrin dans un endroit humide.
- Ne pas boucher les prises d'air de ventilation.
- Éviter le chargement mal réparti de l'équipement sur le lutrin. Un chargement mal réparti risque de faire basculer le lutrin en déplacement.
- Interdire à quiconque de s'asseoir, de se tenir debout ou de grimper sur le lutrin.
- Passer un chiffon doux ou une éponge, imbibés de solution nettoyante ou de savon liquide doux, sur les surfaces sales. Ne pas utiliser des solvants rudes ou des abrasifs.
- Ce lutrin est destiné à un usage institutionnel. Il ne contient aucune pièce susceptible d'être réparée par l'utilisateur et ne nécessite aucun entretien de la part de celui-ci. Si une maintenance est requise, communiquer avec Spectrum Industries pour obtenir de l'aide.

### Consignes de sécurité en électricité

- Ne pas brancher le cordon d'alimentation sur une rallonge.
- Vérifier que les cordons d'alimentation sont intacts avant chaque utilisation. Ne pas les utiliser s'ils sont abîmés.
- Pour débrancher le cordon de la prise murale, saisir son bouton isolant et tirer; ne pas tirer le cordon.
- Ne pas marcher, ne pas rouler et ne pas placer des objets sur le cordon d'alimentation; ne pas le traîner.
- Pour plus de sécurité, brancher le lutrin sur une prise mise à la terre protégée par un disjoncteur de fuite de terre.
- Les appareils électriques ne sont pas des jouets. Les enfants n'ont souvent pas conscience des dangers associés aux appareils électriques. Ce le lutrin doit donc être toujours utilisé par un adulte, ou sous la surveillance d'un adulte.

**Avvertissement** - Reloger un équipement audio ou vidéo sur un meuble non conçu pour supporter cet équipement pourrait entraîner de graves blessures, voire la mort, à la suite de l'effondrement du meuble ou de sa chute sur un enfant.

**Avvertissement** - Un enfant qui grimpe sur un meuble d'équipement audio ou vidéo pourrait subir des blessures graves ou mortelles. Une télécommande ou des jouets placés sur le meuble risquent d'inciter un enfant à y grimper : le meuble pourrait alors basculer et écraser l'enfant.



## Instrucciones importantes de prevención de accidentes y cuidado



- Lea este manual del propietario antes de la instalación u operación.
- No permita que los niños muevan el atril.
- Proceda lenta y cuidadosamente al mover el atril.
- Solo para uso en interiores. No instale o guarde el atril donde quede expuesto a la humedad.
- No obstruya las rendijas de ventilación.
- Evite cargar el equipo de forma desigual dentro del atril. La distribución asimétrica del peso podría provocar que el atril se vuelque al momento de moverlo.
- No permita que nadie se siente, pare o suba al atril.
- Para limpiar las superficies sucias, utilice un paño, trapo suave o esponja con jabón neutro o una solución de detergente. No utilice solventes o abrasivos ásperos.
- El uso convencional de este atril es institucional. No contiene ninguna parte que pueda ser reparada por el usuario ni requiere de mantenimiento por parte de éste. Si fuera necesario darle mantenimiento, póngase en contacto con Spectrum Industries para obtener asistencia.

### Prevención de accidentes eléctricos:

- No enchufe el cable de alimentación a un cable de extensión.
- Revise que los cables de alimentación no tengan ningún daño antes de cada uso. No utilice cables de alimentación que estén dañados.
- Desenchufe el cable de alimentación del tomacorriente eléctrico sosteniendo el cable firmemente. No desenchufe el cable de alimentación jalando únicamente del cable.
- No se pare, circule, jale o coloque ningún objeto sobre el cable de alimentación.
- Para mayor seguridad, enchufe el atril a una conexión a tierra controlada por un interruptor de circuito GFI (interruptor de fallas de conexión a tierra).
- Los dispositivos eléctricos no son juguetes. Los niños generalmente no están conscientes de los riesgos asociados con los dispositivos eléctricos. Este atril lo deberán utilizar siempre personas adultas o bajo su supervisión.

**Advertencia:** reubicar equipo de audio y/o video a un mueble que no haya sido diseñado específicamente para tal uso, puede provocar la muerte o lesiones graves debido a que puede colapsarse o volcarse sobre un niño.

**Advertencia:** existe peligro de muerte o lesiones graves si los niños se suben a un mueble de equipo de audio y/o video. Un control remoto o juguete colocado sobre el mueble puede alentar a un niño a subirse y provocar que el mueble se vuelque sobre el chico.



## Product Registration

Dear customer,

Spectrum Industries would like to thank you for your purchase. Please take a moment to register your product for valuable warranty and product information. Locate the product and serial numbers on the label located either on the inside of the front door, or under the main worksurface. Record the numbers here to enter online.

If you have any questions or concerns about the product you received, please contact us.

Product Number:

Serial Number:

**1-800-235-1262**

Toll-free HELPLINE

**[spectrum@spectrumbfurniture.com](mailto:spectrum@spectrumbfurniture.com)**



Learn more at:



[spectrumbfurniture.com/register](https://www.spectrumbfurniture.com/register)

## Warranty

### We will make it right for you!

Thanks for choosing Spectrum! Spectrum is committed to provide complete customer satisfaction. Each of our products is manufactured from the best materials available and each product is stringently monitored throughout the production process through our P.A.C.E. program (Product Assurance to meet Customer Expectations).

We expressly warrant that Spectrum products will be of good quality and workmanship and free from defect for the period set out in the warranty from the date of delivery.

**For a listing of all product specific warranty terms please visit our website at:**

<https://www.spectrumbfurniture.com/en/resources/purchasing-terms-warranty>



Spectrum Industries is Certified ISO 9001:2015