

Technical Specifications

55542

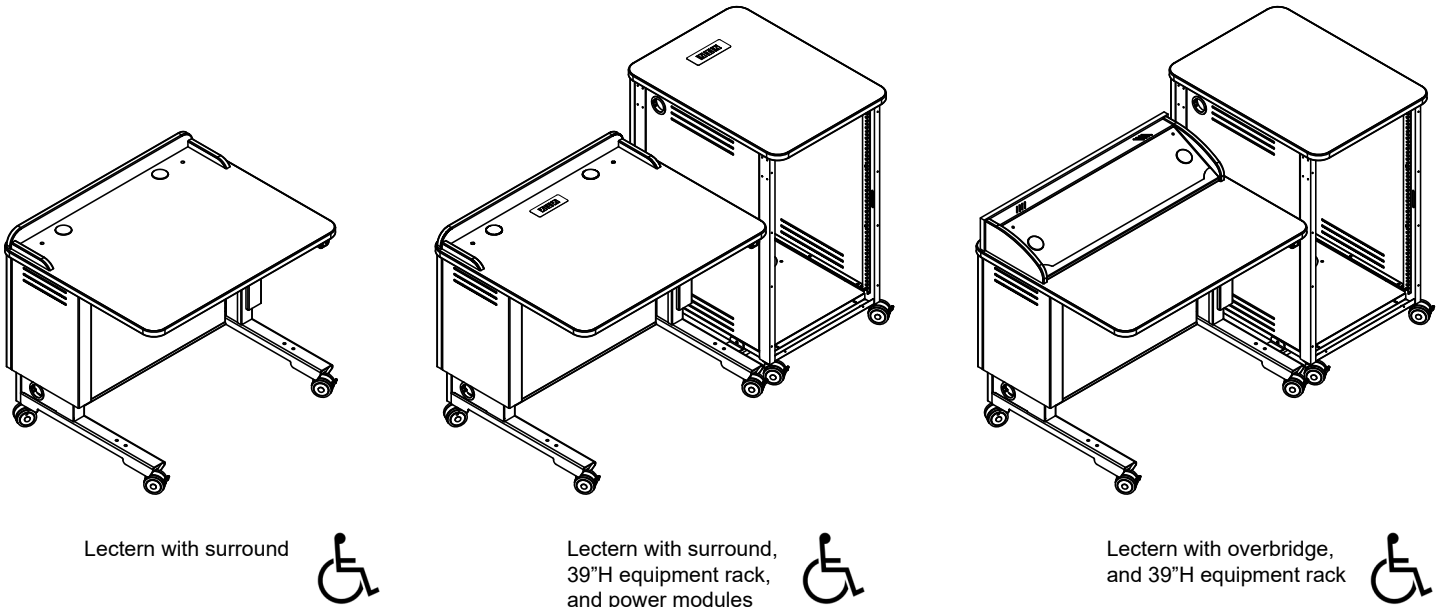

Lectern with surround



Lectern with surround,
39\"/>



Lectern with overbridge,
and 39\"/>



Use the Freedom One e-Lift Lectern where worksurface height adjustment, ADA compliance, or rack rail equipment storage is required. The lectern can have either glides or casters installed for stationary or mobile use. Electric actuators provide worksurface height adjustment from 28.5-42\"/>

Features and Benefits

Lectern:

- Electric eLift adjustable-height worksurface easily adjusts between varying seated or standing-use heights
- Lightweight with a small overall footprint
- ADA-compliant
- Surround on worksurface provides privacy and styling (surround version)
- Worksurface grommet holes provide superior cord access (surround version)
- Casters or glides factory-assembled
- Full-length modesty panel (worksurface to casters)
- Kick panel and wire loom protect cables during worksurface movement
- Overbridge version with blank panel allows custom cutouts and installation of electronics
- Lectern and equipment rack can be assembled in a left or right-hand configuration
- Cable grommets throughout lectern provide cable access
- Pre-drilled monitor arm mounting holes allow easy installation of a monitor arm (surround version only)
- Optional tray can be used as a keyboard tray or storage drawer
- Optional quick-change customizable logo panel simplifies adding or changing logos
- Available as a stand-alone lectern

Equipment Rack:

- Available in 32\"/>

Misc:

- 3\"/>

Color Options

Available in Spectrum Expressions colors.
See spectrumfurniture.com for complete color information.

Ordering Instructions

Spectrum has designed this product to receive the useful options shown here.
To ensure your options are ordered correctly please call 1-800-235-1262.

Construction

- The worksurfaces are constructed from 1" thick NAF (No Added Formaldehyde) composite board plus .030" high-pressure laminate on one face, and a balancing phenolic backer on the opposing face
- Metal components consist of 16-gauge steel
- Worksurface edges are covered with 3mm vinyl
- All metal components are finished with a scratch-resistant powder coat epoxy
- Each Freedom One eLift Lectern ships assembled with casters/glides. Equipment rack ships without casters/glides (installed by customer). Unit-to-unit kit is required to attach equipment rack to lectern.

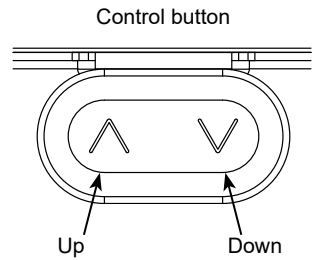

Specifications

eLift Lectern worksurface height adjustability (floor to top of worksurface)	42"H [106.7 cm] (fully-raised with casters) 28.5"H [72.4 cm] (fully-lowered with casters)	
eLift Lectern electrical	<ul style="list-style-type: none"> • Range of motion: 13.5" [34.3 cm] • ~9.7 seconds from fully-lowered to fully-raised • Inverter: 120V @ 60Hz, max output 400 watts • Motors: 18V / 10 amps • Typical electrical load during operation: 4.3 amps @ 120 VAC • Anti-collision protection for safety • 11' [335 cm] nominal 3-wire power cord 	<ul style="list-style-type: none"> • Casters / glides factory-assembled • Max load: 800N (180 lb) [81.7 kg] per actuator total lift capacity: 360 lb [163 kg] • Actuators feature non-hydraulic, permanently lubricated screw jacks • Actuators rated for 20,000 cycles • Tested at 1000 cycles at 300 lb • Approved according to EN 60335-1 and UL 962
Equipment rack	<ul style="list-style-type: none"> • 18RU (39"H), 14RU (32"H) • Front and rear rack rails • Standard audience-side panel included • Casters / glides assembled by customer 	<ul style="list-style-type: none"> • 32"H or 39"H worksurface height (with casters) • Two 2" grommets in each side panel provide cord access • One equipment rack can be attached to the left <u>and</u> right sides of the lectern.
3" Twin Wheel casters	<ul style="list-style-type: none"> • Weight capacity 165 lb [74.9 kg] each • 1/2-13 threaded stem • 4 on equipment rack, 4 on lectern 	
ADA-compliance*	 <p>Knee clearance: 30"W [76.2 cm] x 19"D [48.26 cm] x 27.26"H [69.2 cm] (1 person per lectern)</p>	<p><i>*Minimum ADA guidelines for knee clearances are 30"W [76.2 cm] x 19"D [48.3 cm] x 27"H [68.6 cm]</i></p>
Certifications / Compliance	<ul style="list-style-type: none"> • SCS Indoor Advantage Certified 	<ul style="list-style-type: none"> • Meets or exceeds applicable ANSI-BIFMA test standards
Unit weight (nominal)	151 lb [68.6 kg] - Freedom One Lectern 83 lb [37.7 kg] - 39" Equipment rack 69 lb [31.3 kg] - 32" Equipment rack 9 lb [4.1 kg] - Unit-to-unit bracket	

Specifications subject to change without notice

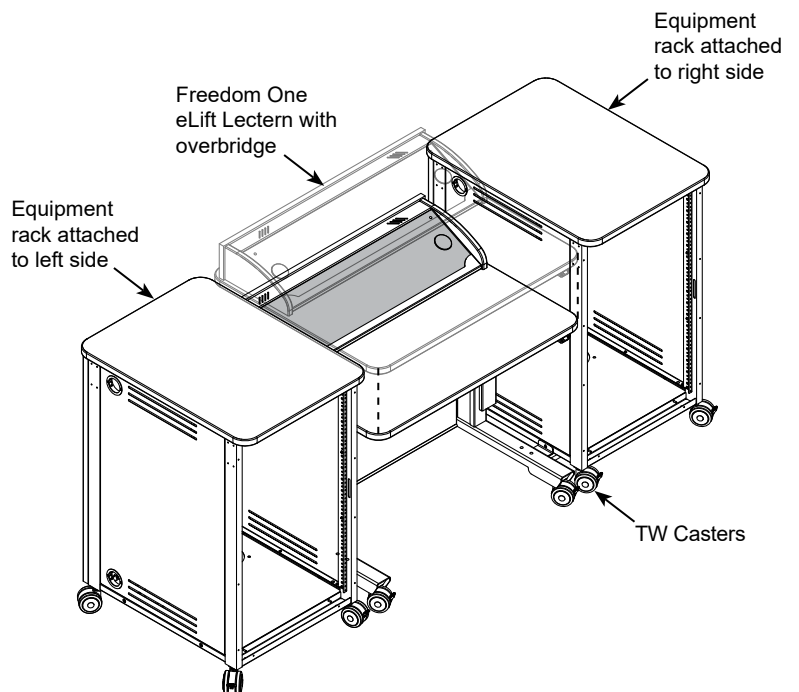
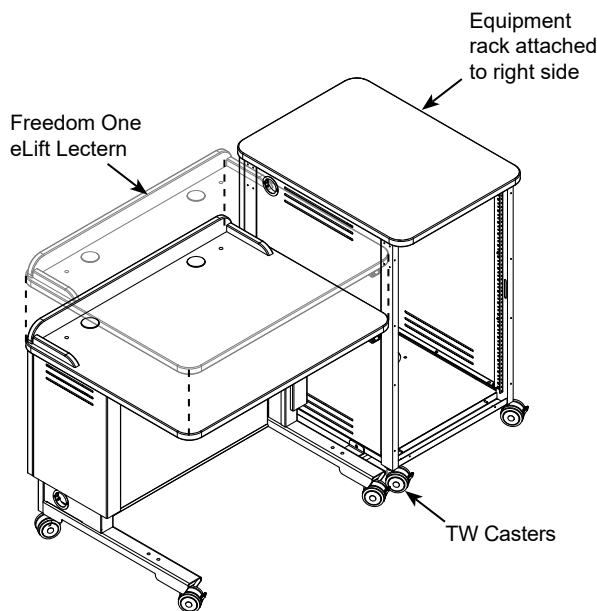

Note: Not designed to be permanently anchored to the floor. Optional glides are available if a stationary lectern is needed.

Surround

Overbridge

Plain Worksurface

ORDER CODE S1 = Surround

ORDER CODE B3 = Overbridge (2-pc panel)

ORDER CODE P1 = Plain worksurface

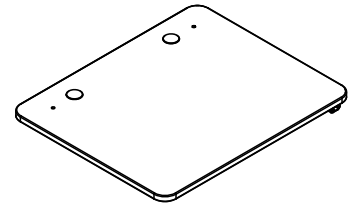
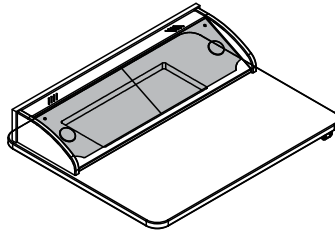
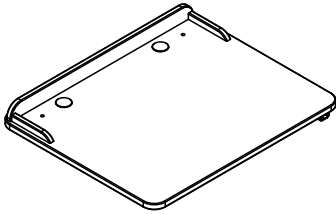

ORDER CODE S2 = Surround
w/ custom cutout(s)

ORDER CODE B2 = Overbridge
w/ custom cutout(s)

ORDER CODE P2 = Plain worksurface
w/ custom cutout(s)

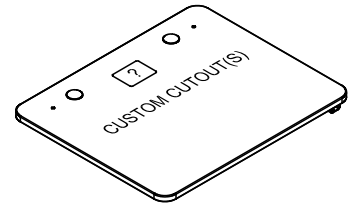
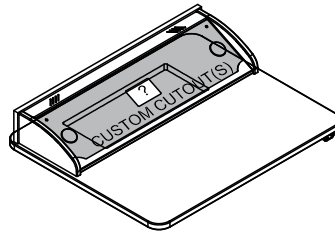
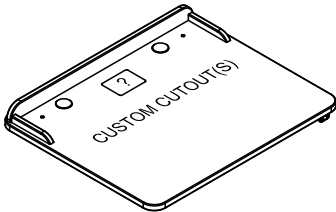

- Contact Spectrum to specify cutout size(s) and location(s) on worksurface
- See p.12 for location recommendations

- Contact Spectrum to specify cutout size(s) and location(s) on overbridge panel
- See p.12 for location recommendations

- Contact Spectrum to specify cutout size(s) and location(s) on worksurface
- See p.12 for location recommendations

ORDER CODE B1 = Overbridge (1-pc panel)

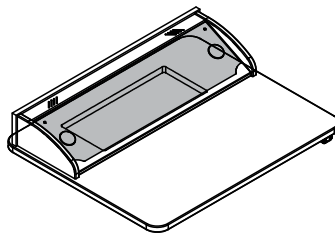

Lectern Installed Power Equipment

ORDER CODE 0 = None

ORDER CODE 1 = Power Module - Black

ORDER CODE 2 = Power Module - Silver

ORDER CODE 3 = Power Module - White

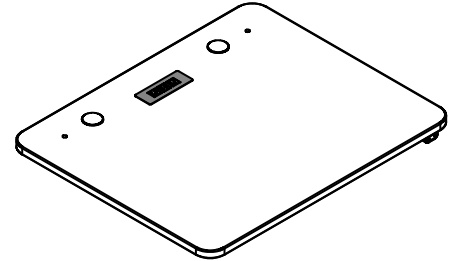
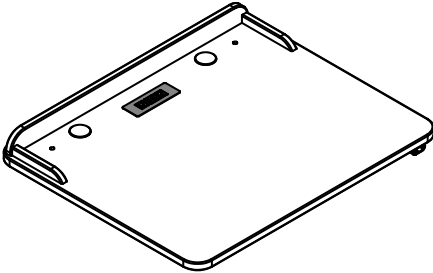
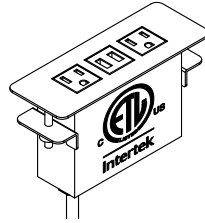

ORDER CODE 4 = Power Module - Black & EM Wireless Charging Pad

ORDER CODE 5 = Power Module - Silver & EM Wireless Charging Pad

ORDER CODE 6 = Power Module - White & EM Wireless Charging Pad

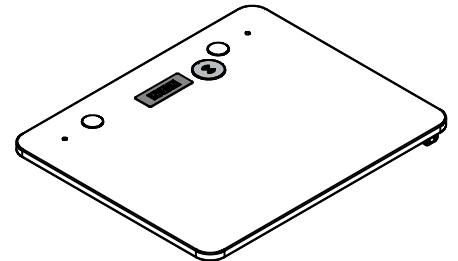
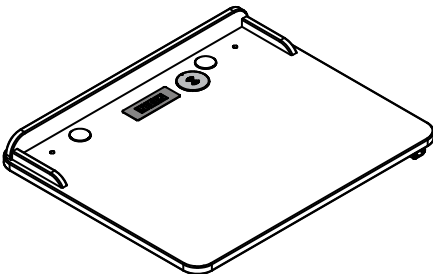
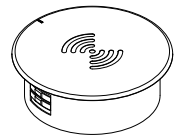
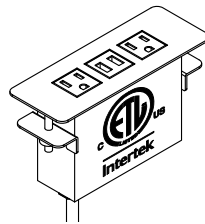

ORDER CODE 7 = Wireless Charging Pad

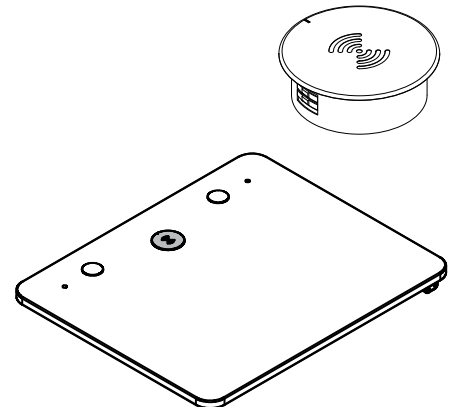
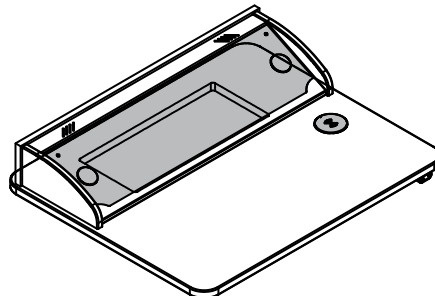
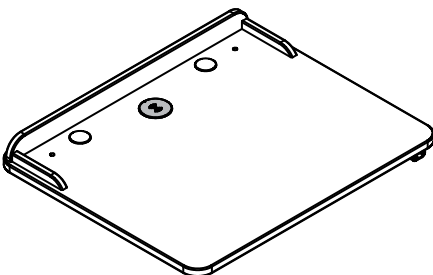

Lectern Customized Logo Panel

ORDER CODE 0 = None

ORDER CODE 1 = Yes (with matching laminate backer)

ORDER CODE 3 = Yes (with black laminate backer)

ORDER CODE 4 = Yes (with white laminate backer)

ORDER CODE 5 = Custom printed backer

- Attaches to audience-side of lectern
- To get panel customized-contact Spectrum for details
- New logos require a first time logo charge

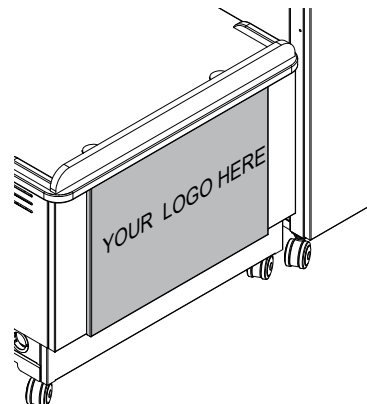

ORDER CODE 0 = None

ORDER CODE A = 32"H (14RU) Equipment Rack

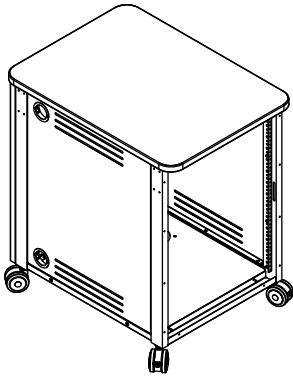

- 32"H with casters
- 29.5"H with glides

ORDER CODE F = 39"H (18RU) Equipment Rack

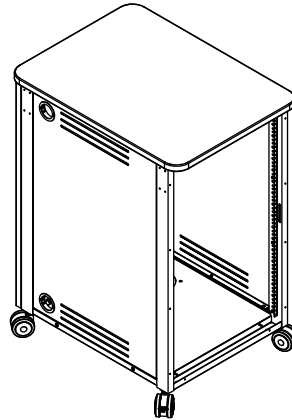

- 39"H with casters
- 36.5"H with glides

ORDER CODE C = 32"H Equipment Rack w/ Power Module - Black

ORDER CODE D = 32"H Equipment Rack w/ Power Module - Silver

ORDER CODE E = 32"H Equipment Rack w/ Power Module - White

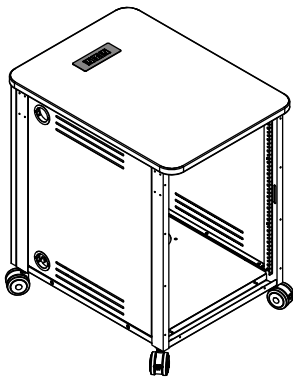
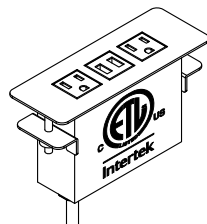

- 32"H with casters
- 29.5"H with glides

ORDER CODE H = 39"H Equipment Rack w/ Power Module - Black

ORDER CODE J = 39"H Equipment Rack w/ Power Module - Silver

ORDER CODE K = 39"H Equipment Rack w/ Power Module - White

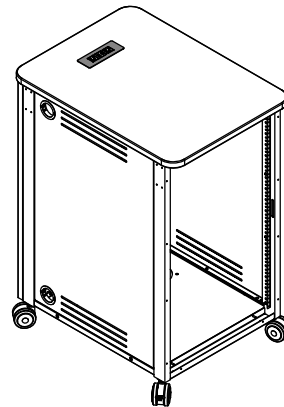
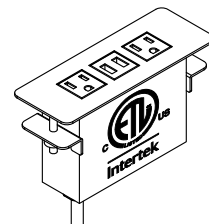

- 39"H with casters
- 36.5"H with glides

ORDER CODE B = 32"H (14RU) Equipment Rack w/ Custom cutout

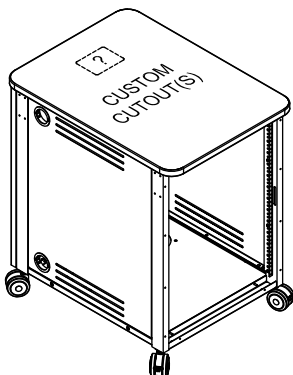

- Contact Spectrum to specify cutout size(s) and location(s) on worksurface
- See p.12 for location recommendations

ORDER CODE G = 39"H (18RU) Equipment Rack w/ Custom cutout

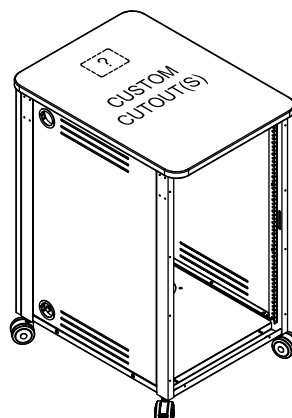

- Contact Spectrum to specify cutout size(s) and location(s) on worksurface
- See p.12 for location recommendations

Equipment Rack Door(s)

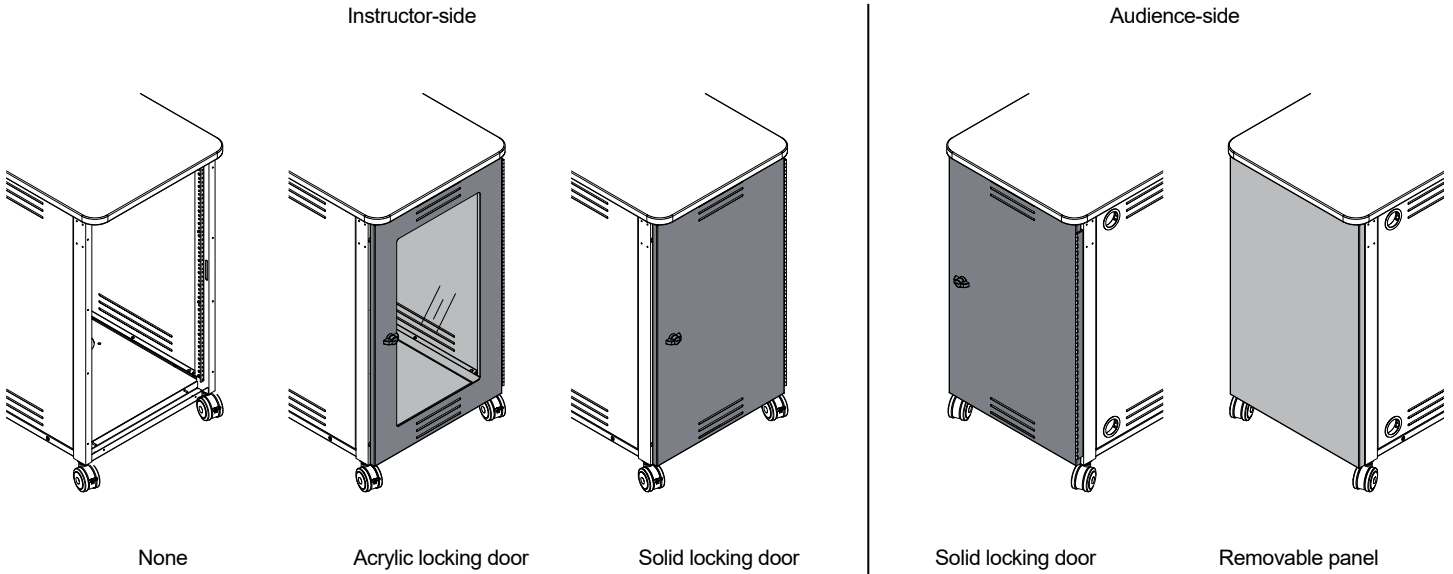

ORDER CODE 0 = No doors

ORDER CODE 1 =	Audience-side: Solid locking door Instructor side: None
ORDER CODE 2 =	Audience-side: Removable panel Instructor side: None
ORDER CODE 3 =	Audience-side: Solid locking door Instructor side: Solid locking door

ORDER CODE 4 =	Audience-side: Solid locking door Instructor side: Acrylic locking door
ORDER CODE 5 =	Audience-side: Removable panel Instructor side: Solid locking door
ORDER CODE 6 =	Audience-side: Removable panel Instructor side: Acrylic locking door

Flip-up Shelf / Keyboard Tray

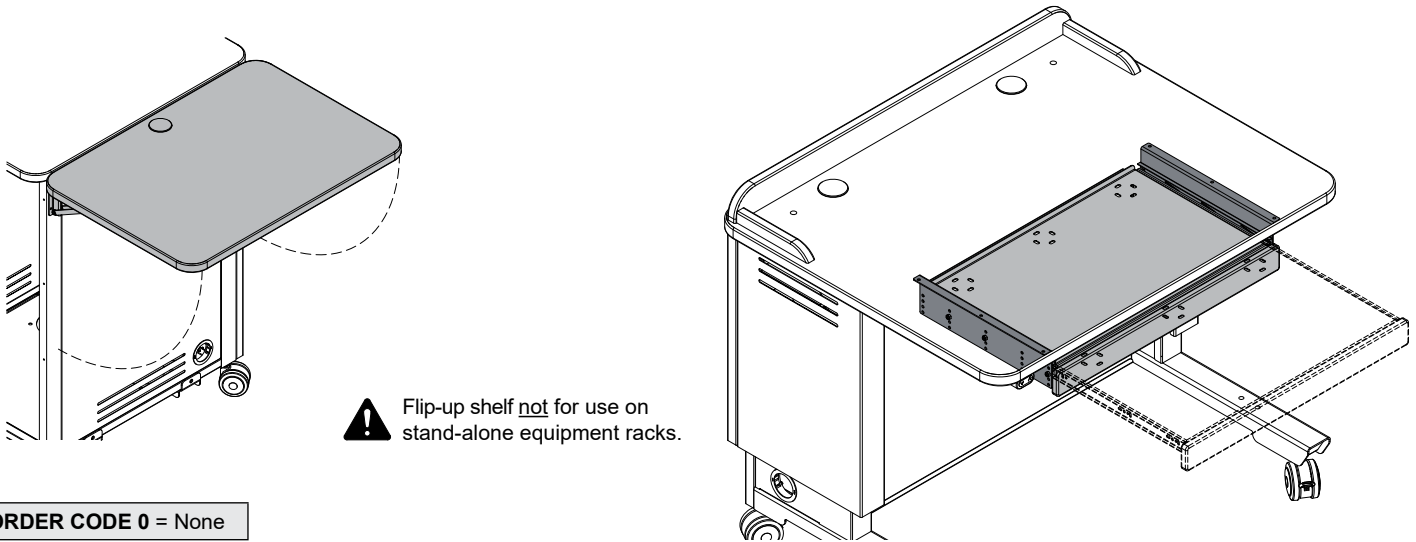

! Flip-up shelf not for use on stand-alone equipment racks.

ORDER CODE 0 = None

ORDER CODE A =	Flip-up Shelf on Equipment Rack (matching laminate)
ORDER CODE B =	Flip-up Shelf on Equipment Rack (Chalk white dry erase)

ORDER CODE C = Keyboard Tray on Lectern

ORDER CODE D =	Keyboard Tray on Lectern & Flip-up Shelf on Equipment Rack (matching laminate)
ORDER CODE E =	Keyboard Tray on Lectern & Flip-up Shelf on Equipment Rack (Chalk white dry erase)

Note: Flip-up shelf is customer-installed.

ORDER CODE 01 = 3" Twin-wheel casters

- For mobile use
- 3.21"H [8.15 cm]
- 1/2-13 threaded stem
- Black, soft thermoplastic
- Factory installed on Lectern
- Customer installed on Equipment Rack

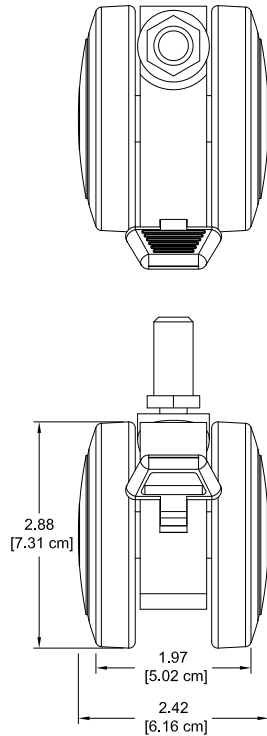
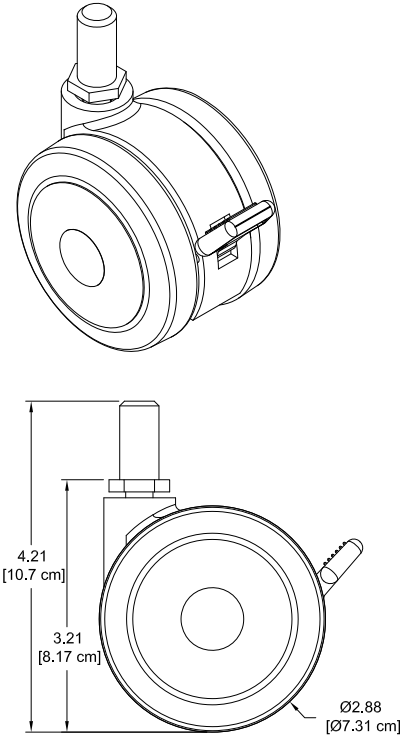

ORDER CODE 02 = Glides

- For stationary use
- .69"H [1.75 cm]
- 1/2-13 threaded stem
- Black high-impact plastic
- Factory installed on Lectern
- Customer installed on Equipment Rack

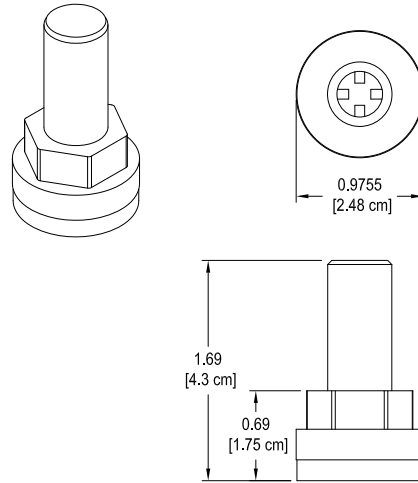

Note: If the lectern or equipment rack is ordered with glides, the overall height is lowered by 2.52" [6.4 cm]. Using glides does not affect ADA-compliance of the lectern.

Freedom One eLift Lectern
 shown with surround, TW casters,
 and keyboard tray

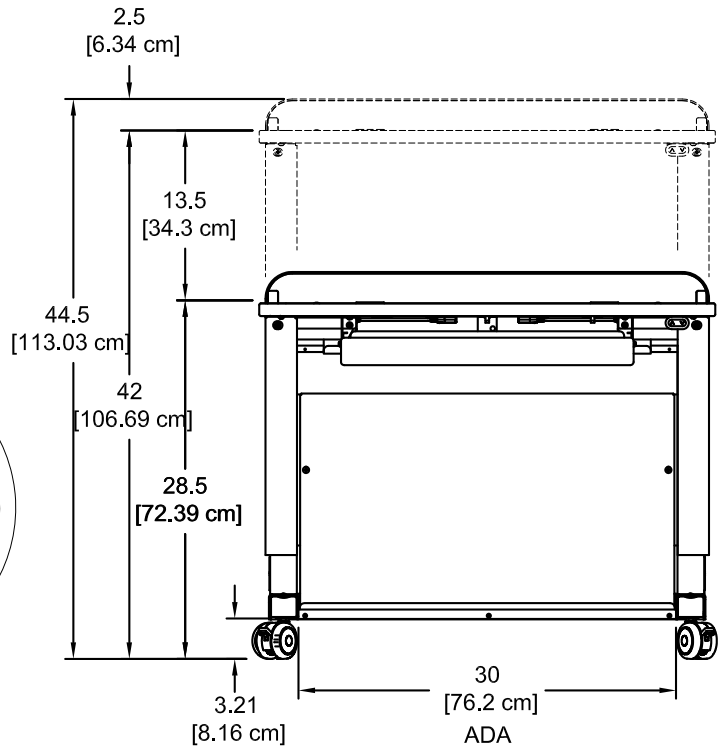
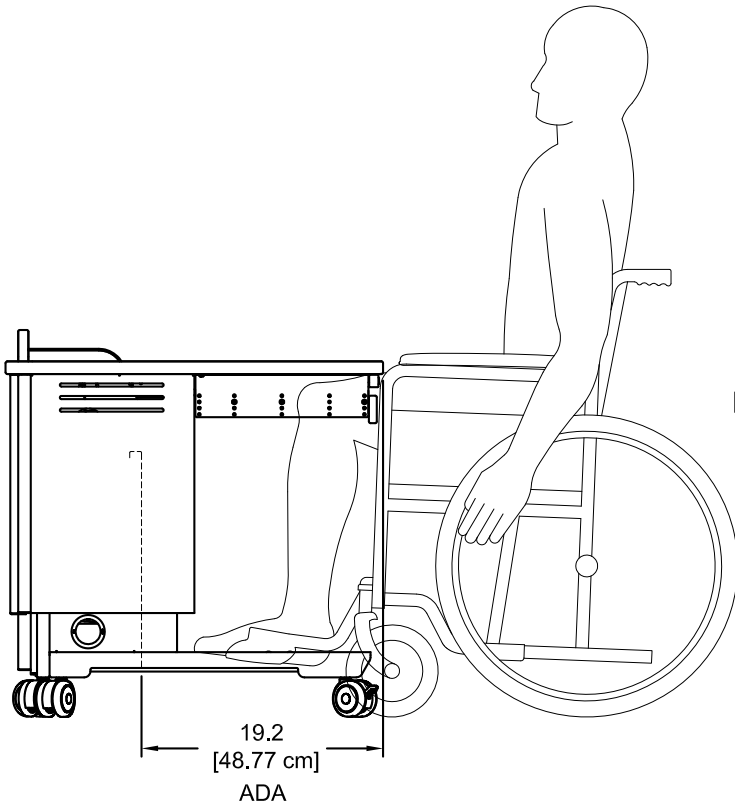
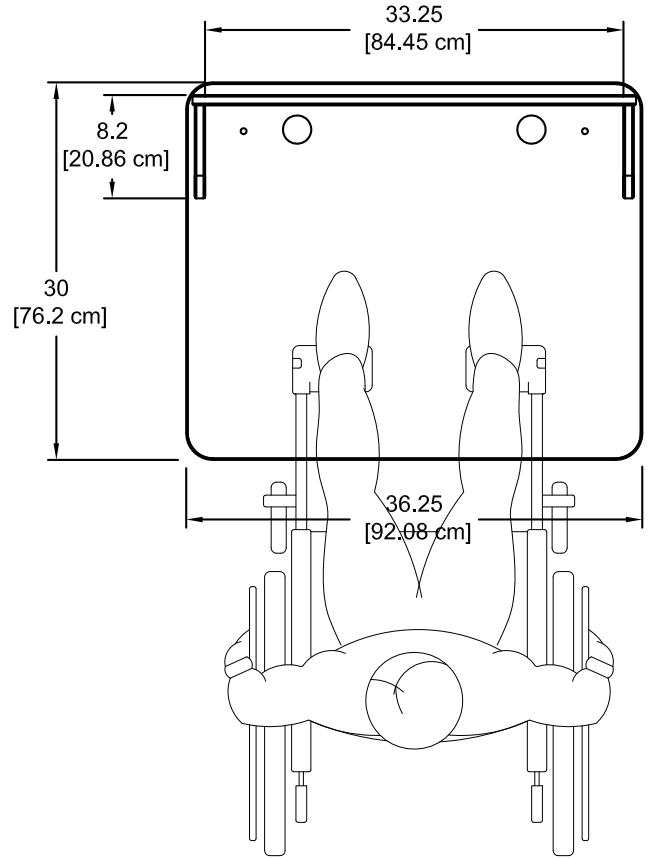
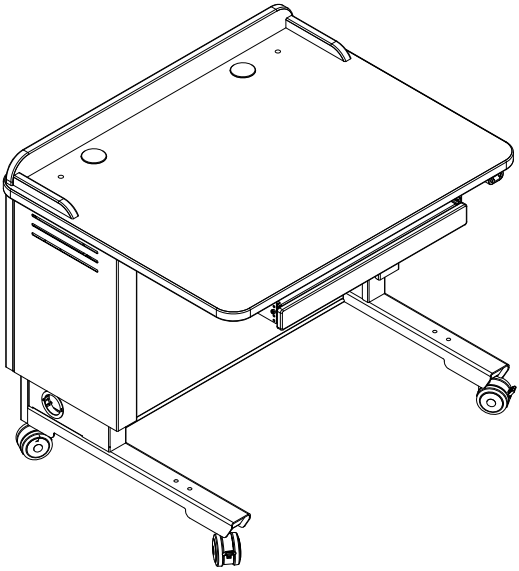

Freedom One eLift Lectern
 shown with overbridge, TW casters,
 right-assembled 39" equipment
 rack, and keyboard tray

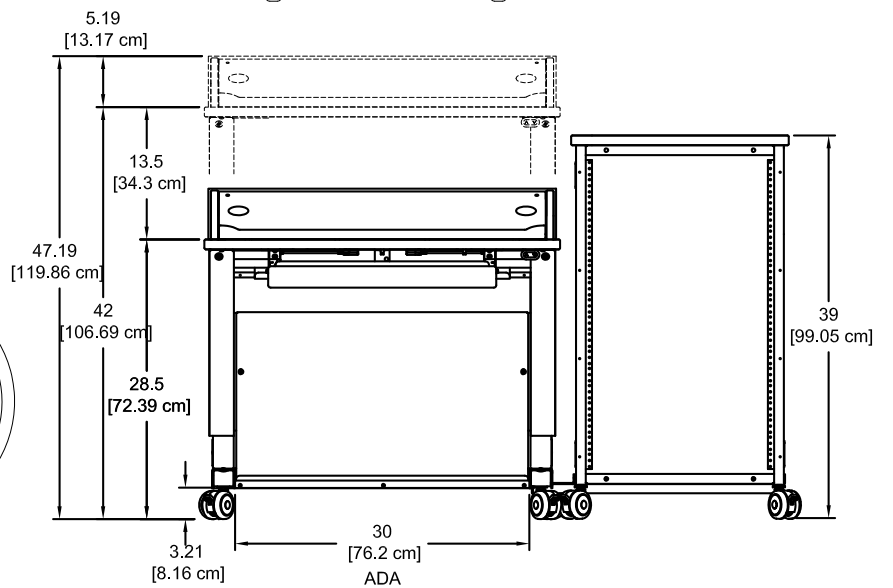
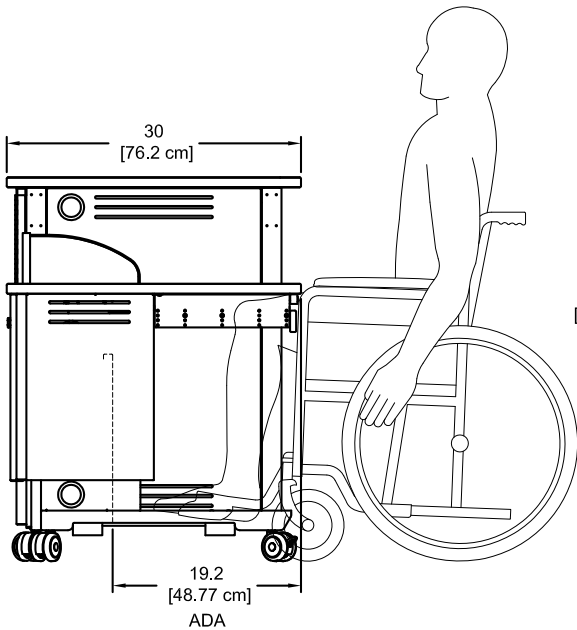
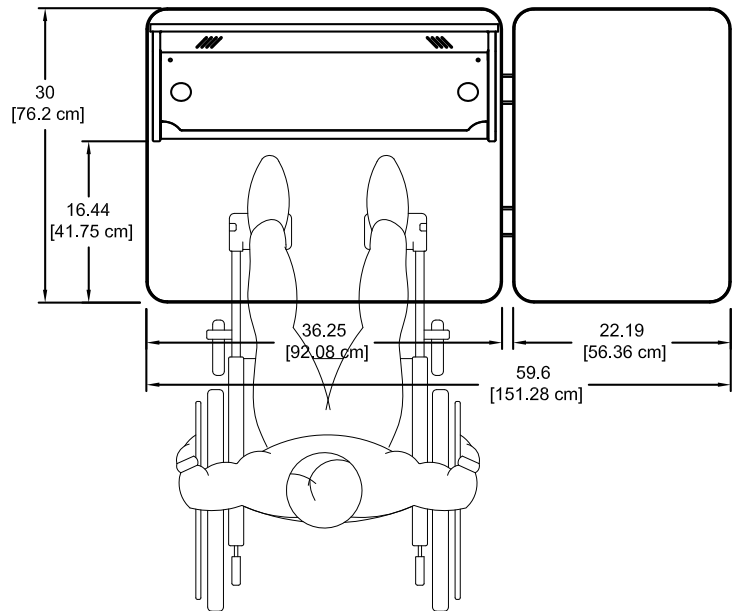
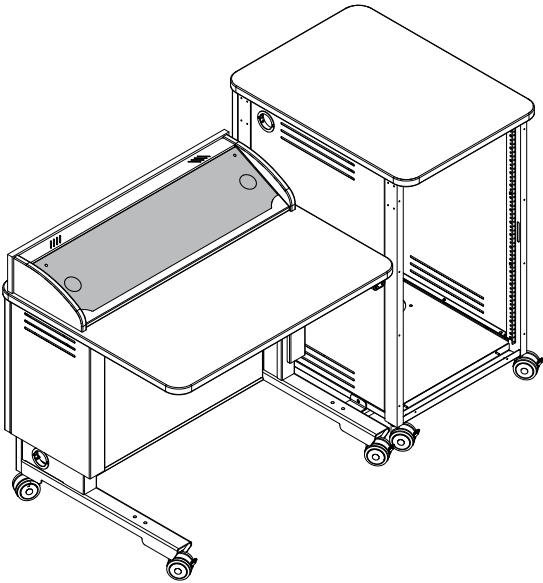

32"H Equipment Rack (14RU)

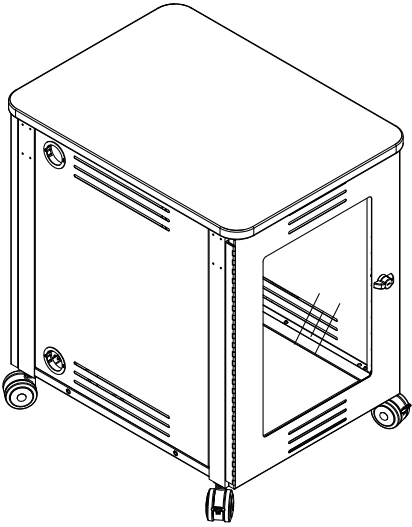

Section View

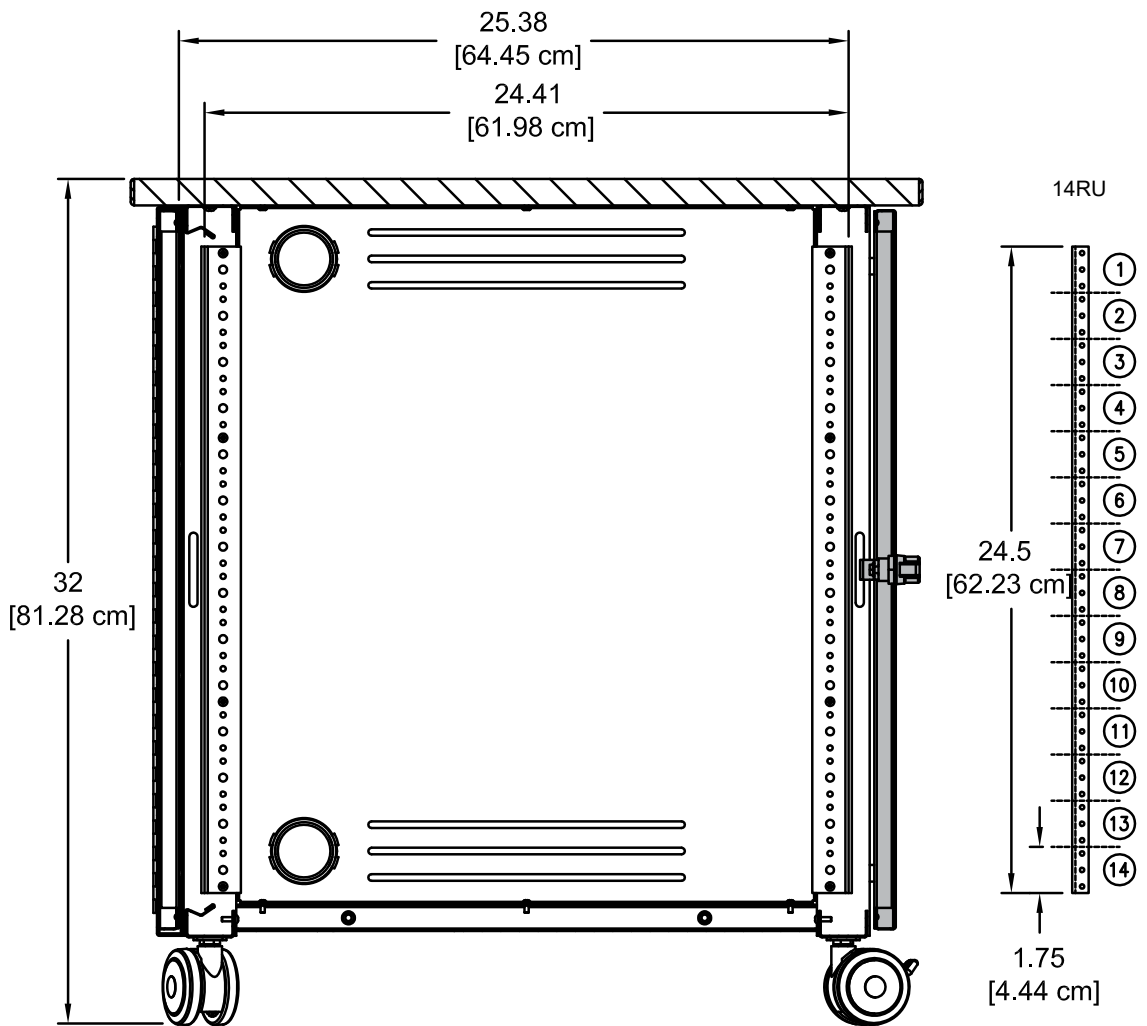

39"H Equipment Rack (18RU)

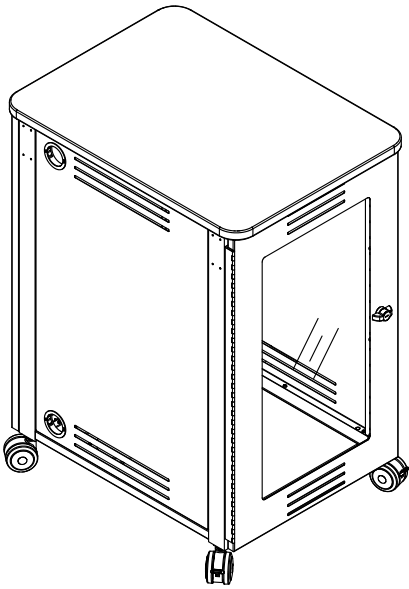

Section View

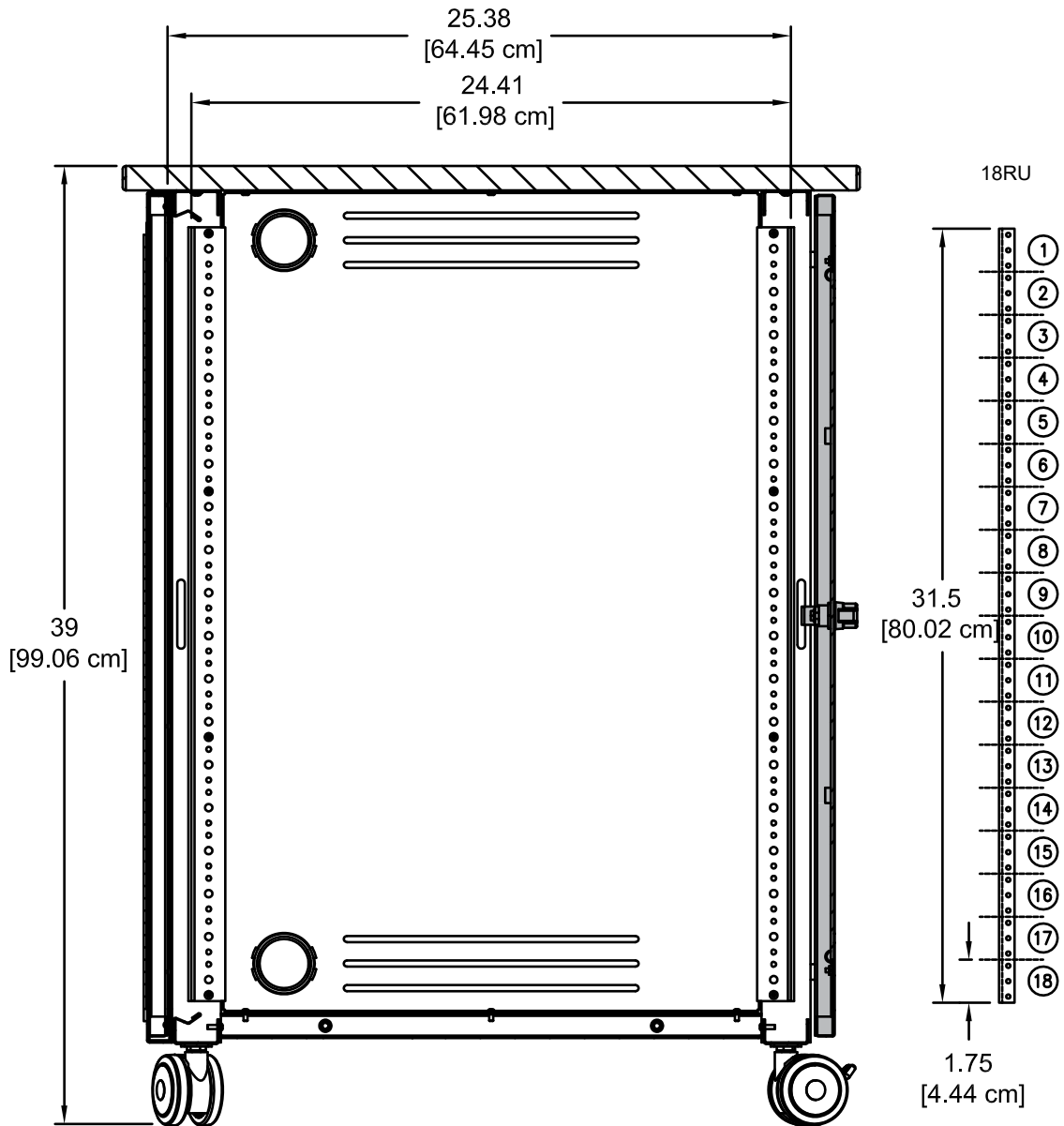

2-piece panel

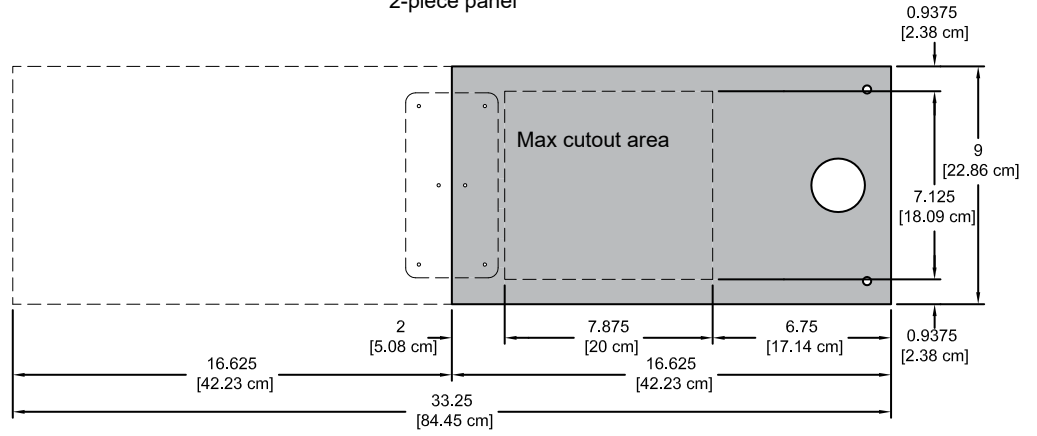
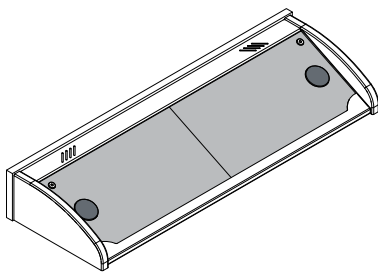

1-piece panel

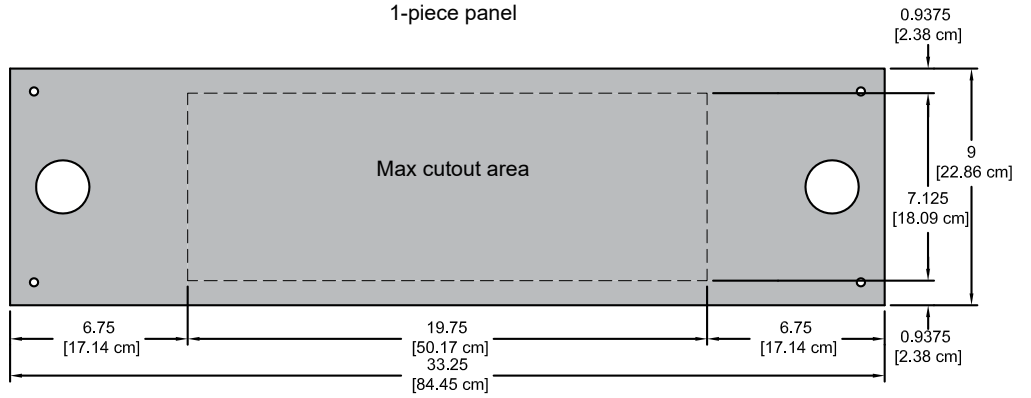
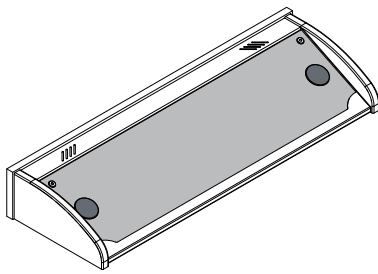

Possible cutout areas in lectern with surround (shown shaded)

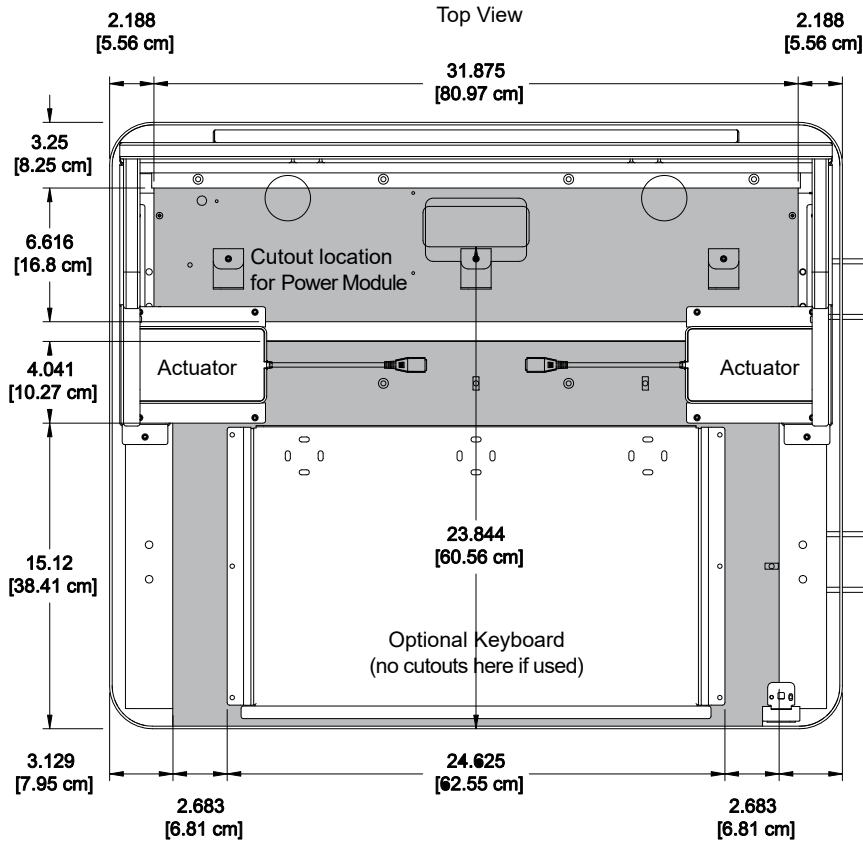

Possible cutout area in Equipment Rack (shown shaded)

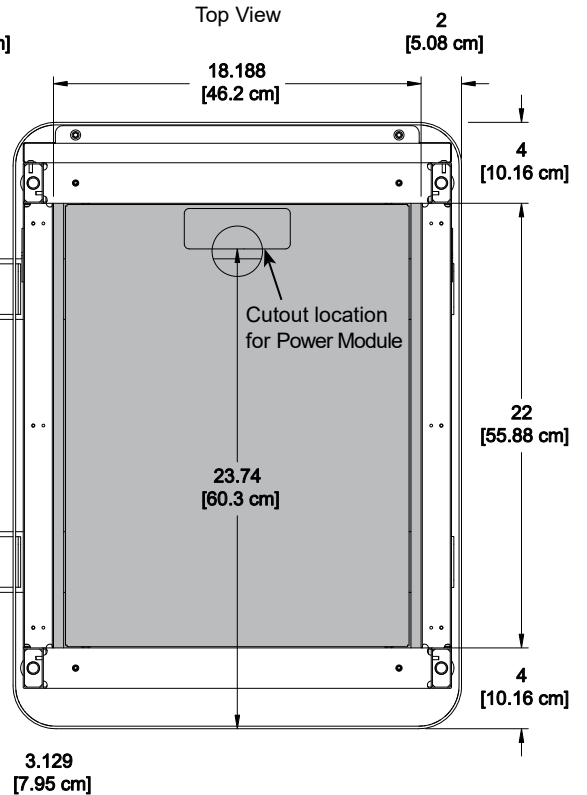

Freedom One eLift Overbridge Insert Panel Blank
(flat view)

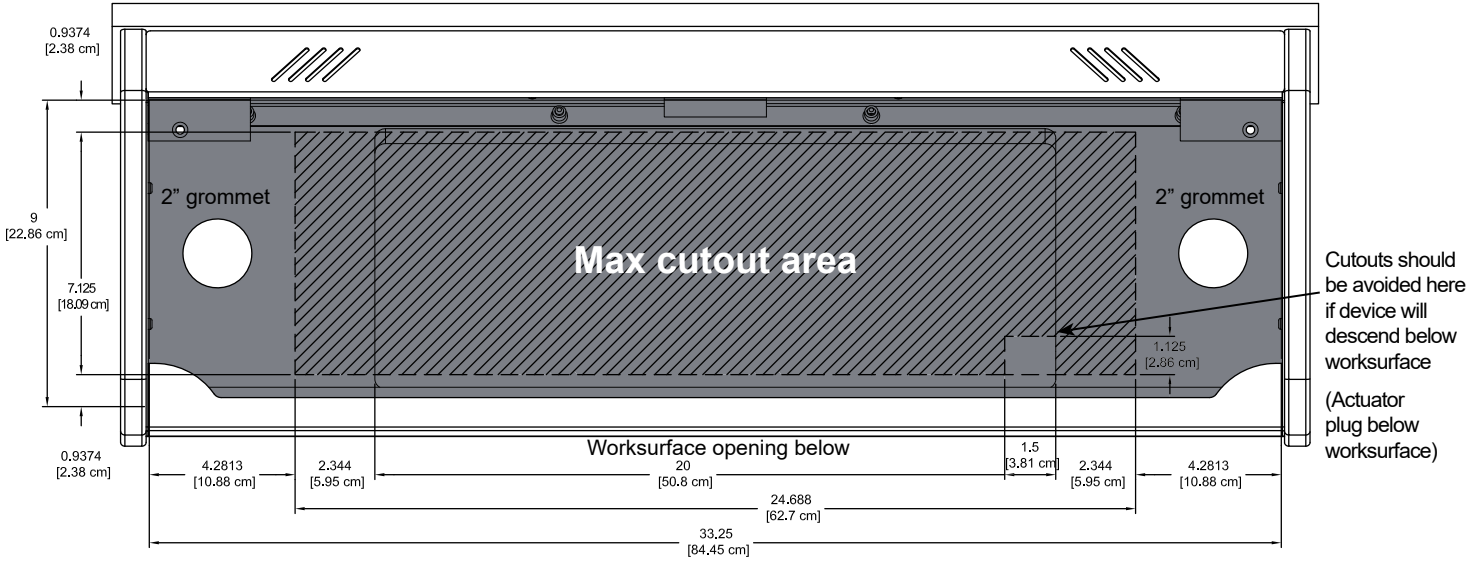

Note: Modified worksurface cutouts should be reviewed by Spectrum to ensure clearance of brackets, keyboard slides, or other objects under the worksurface.
Contact Spectrum to specify cutout size(s) and location(s).

Overbridge section view

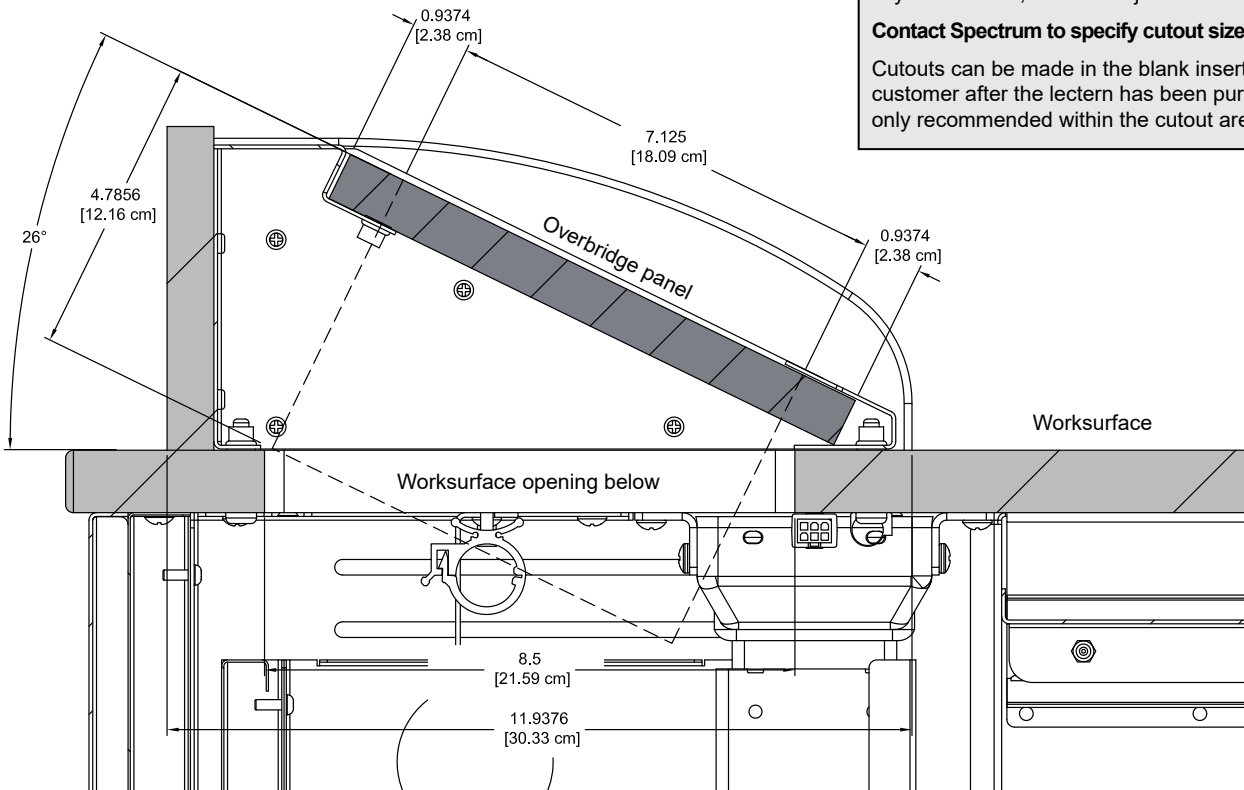

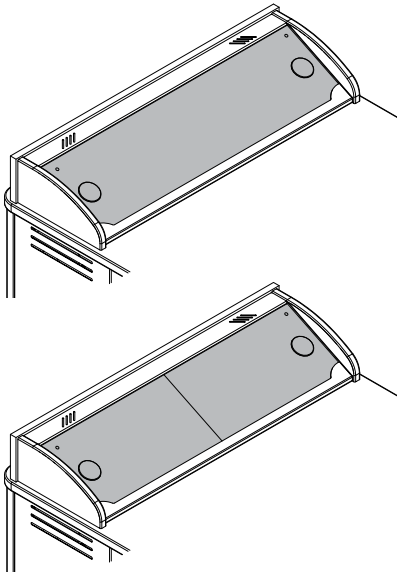

Overbridge Insert Panel-Large

One-piece - 96507

Two-piece - 96513

- Contact Spectrum to specify cutout size(s) and position(s)
- Includes two 2" [5.08 cm] grommets with covers
- Customer-installed

96507 dims:	33.25"W [84.45 cm] x 9"D [22.9 cm] x .79"H [2 cm]
96513 dims:	16.625"W [42.2 cm] x 9"D [22.9 cm] x .79"H [2 cm]
Shipping weight:	8.5 lb [3.9 kg]

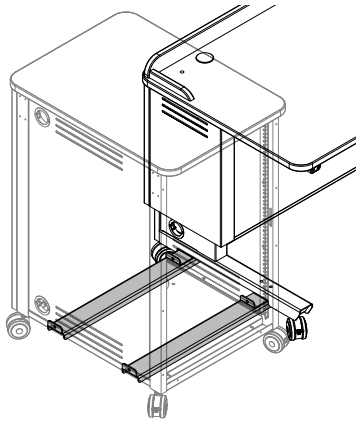

Unit-to-Unit Connector Kit - 55359

- For connecting equipment rack to lectern
- Simple installation-lectern and equipment rack can remain right-side up
- Shipping weight: 9 lb [3.9 kg]

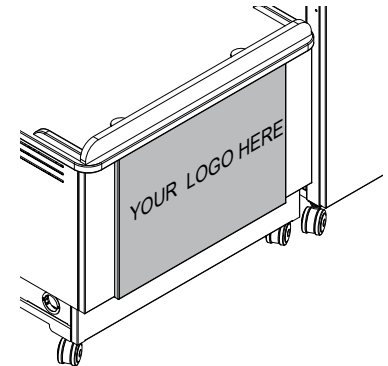

Customized Logo Panel - 55380

- To get a customized logo panel, contact Spectrum to specify all logo details
- New logos require a first time logo charge

Dimensions:	26"W [66 cm] x .625"D [1.6 cm] x 19.09"H [48.5 cm]
Shipping weight:	15 lb [6.8 kg]

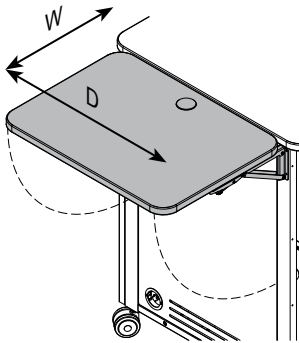

Flip-up Shelf - 55543

- Shelf hinges lock into place in the upright position
- Includes 2" grommet
- Mounts on left or right side of equipment rack
- Available in matching, or White Chalk Dry Erase laminate

Dimensions:	19.25"W [48.9 cm] x 26"D [66 cm] x 1"H [2.54 cm]
Weight capacity:	35 lb [15.9 kg]
Shipping weight:	27 lb [12.3 kg]

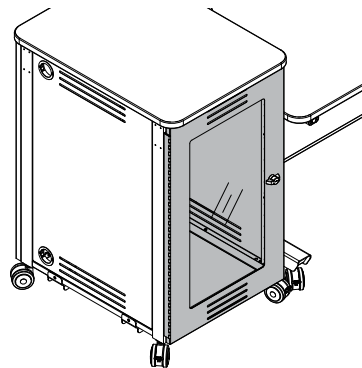

Clear Acrylic Locking Door

39"H - 55512
32"H - 55510

- For instructor-side installation
- Can be installed hinged from the left or right side
- Shipping weight: 13 lb [5.9 kg] (39"H)
11.5 lb [5.2 kg] (32"H)

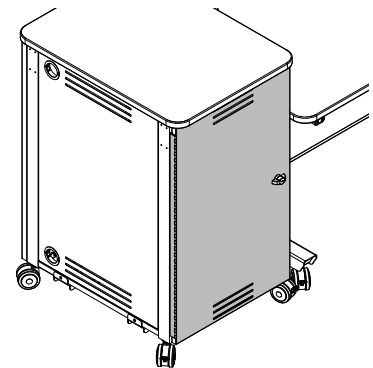

Solid Locking Door

39"H - 55511
32"H - 55509

- For instructor or audience-side installation
- Can be installed hinged from the left or right side
- Shipping weight: 13 lb [5.9 kg] (39"H)
11.5 lb [5.2 kg] (32"H)

Note: When used on the audience-side of the equipment rack, the door will replace the standard audience-side panel.

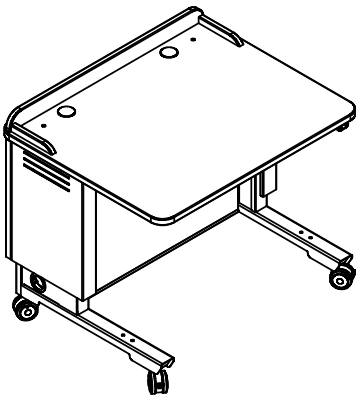

Freedom One eLift Lectern - 55542

- Electrically-adjustable worksurface
- ADA-compliant
- Available in surround or overbridge versions
- Factory-assembled with casters or glides

Lectern Style:	<ul style="list-style-type: none"> • Surround • Overbridge
Worksurface options:	<ul style="list-style-type: none"> • No Cutouts • Custom Cutouts
Base options:	<ul style="list-style-type: none"> • Twin Wheel Casters • Glides
Shipping weight: (nominal)	151 lb [68.6 kg]

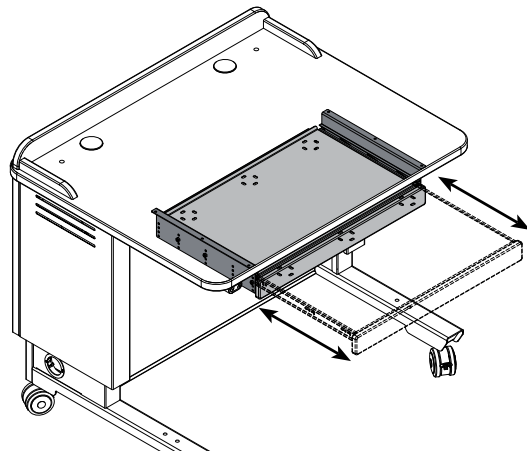

Keyboard Tray - 55379

- Tray can be installed and used as a keyboard tray or flipped and used as a storage drawer using pre-drilled mounting holes under the lectern worksurface.
- Wire management slots in tray

Dimensions:	22"W [55.9 cm] x 13.815"D [35.1 cm] x 4"H [10.2 cm]
Weight capacity:	25 lb [11.4 kg]
Shipping weight:	14 lb [5.4 kg]

Note: The keyboard tray protrudes 3.4375" [8.73 cm] below the work-surface. If the lectern is used for ADA use, a higher adjusted worksurface (around 32"H) is necessary to provide wheelchair clearance.

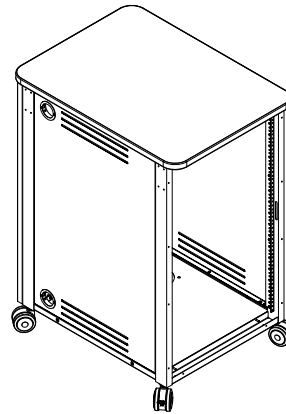

Equipment Rack for Freedom One eLift - 55508

- 39"H (18RU) or 32"H (14RU)
- Front and rear rack rails
- Standard audience-side panel included
- Casters / glides assembled by customer
- 39"H [99.3 cm] or 32"H [81.3 cm] worksurface height (with casters)
- Two 2" grommets in each side panel provide cord access
- Up to two equipment racks can be attached to the lectern (1 on left and 1 on right)

Worksurface options:	<ul style="list-style-type: none"> • No Cutouts • Custom Cutouts • Power Module
Base options:	<ul style="list-style-type: none"> • Twin Wheel Casters • Glides
Door options:	<ul style="list-style-type: none"> • Solid door • Acrylic door
Shipping weight: (nominal)	<ul style="list-style-type: none"> • 116 lb [52.7 kg] (39"H) • 102 lb [46.3 kg] (32"H)

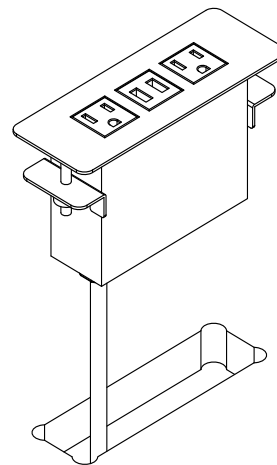

Power Module - 99058

- (2) AC power receptacles
- (2) USB charge ports
- Aluminum housing and flange
- Thumbscrew clamps
- Requires worksurface cutout
- ETL-certified
- Available in black, silver, or white
- Customer-installed

Cutout required:	5.65"W [14.35 cm] x 1.65"D [4.19 cm]
Power cord:	9' [274 cm] 14AWG *3C power cord
Power receptacles:	125V, 60hz, 15A tamper-resistant
USB charging ports:	2.1A (10.5W) (not data-compatible)
Dimensions:	6.38"W [16.2 cm] x 2.36"D [6 cm] x 3.54"H [9 cm]
Unit weight:	2 lb [.9 kg]
Shipping weight:	2.35 lb [1 kg]



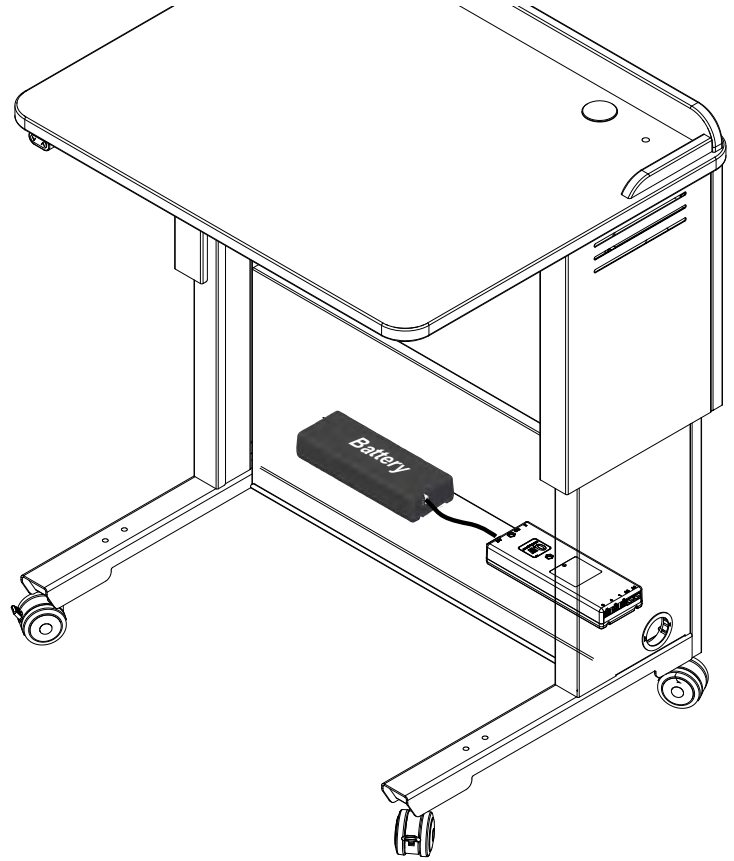

Rechargeable Battery Pack System - 99045

- Creates a mobile lectern / desk by providing the ability to operate the unit in locations without AC power
- Compact, lightweight lithium-ion battery plugs into and charges from the existing lectern control box
- On-board LED light bars indicate charge capacity level
- Audio alarm signals when charging is needed
- Thermal switch protection, overcurrent protection
- Easy customer-installation

Battery Type	Lithium-ion
Capacity	2.2 Ah / 53 Wh
Voltage (nominal)	24V
Discharge current	9A (max)
Max charging voltage	40V DC
Charging current	0.5 A
Certifications	EN 62133 (Battery safety testing) UL 1642 (Lithium cells, standard test) UN 38.3 (Transportation of Lithium batteries) UL 2054 (Household and commercial batteries) EN 60335-1 with CBH Advanced
Unit weight: (nominal)	1.32 lb [.6 kg]
Shipping weight: (nominal)	2 lb [.9 kg]

Battery / Control Box Compatibility:

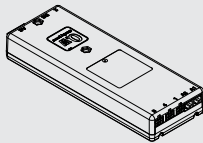

The CBD6S Linak control box is compatible with this battery pack.



Older CBD4 Linak control boxes are not compatible with this battery pack.



Flat Panel Monitor Arm

- 95512** - for monitors weighing 2-13 lb
- 95522** - for monitors weighing 7.5-25 lb
- 95509** - for monitors weighing 12-31 lb

- Six mounting options (clamp, thru-desk, wall, grommet hole, side bolt, reverse wall)
- Compatible with all VESA® monitors - includes 75mm and 100mm VESA® adapters
- Cable management concealed in arm



Dual Flat Panel Monitor Arm - 95533

- Weight range: 3.5-13 lb per monitor
- Six mounting options (clamp, thru-desk, wall, grommet hole, side bolt, reverse wall)
- Compatible with all VESA® monitors - includes 75mm and 100mm VESA® adapters
- Cable management concealed in arm



Heavy-Duty Monitor Arm

- 95539** - without USB & multimedia ports
- 95540** - with USB & multimedia ports

- Adjustable gas spring counterbalance
- Weight range: 2.2-33lb
- Fits most 17-35" monitors
- Quick-release 75mm, 100mm, VESA® mounting plate
- Clamp or grommet mounting
- Optional (2) USB 3.0 ports and (2) 3.5mm jacks for mic / headphones
- Cable management channel



7-Outlet Power Strip - 99024

- Electrical Rating: AC 125V, 15 Amps
- 1000 Joules surge capacity
- 12' cord length
- LED switch
- UL Listed
- Shipping weight: 1.9 lb [.86 kg]

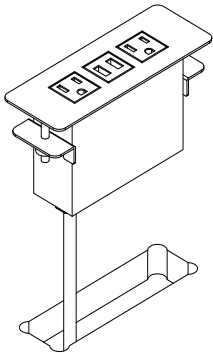

Power Module - 99060

- (2) AC power receptacles
- (2) USB charge ports
- Aluminum housing and flange
- Thumbscrew clamps
- Requires worksurface cutout
- ETL-certified
- Available in black, silver, or white
- Customer-installed

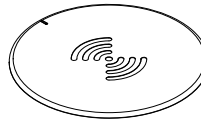

EM Wireless Charging Pad - 99057

- Uses electromagnetic technology to charge Qi V1.2 compliant IC devices ("Qi" enabled)
- LED to confirm pairing / charging
- Security tab prevents theft
- Requires 3" round cutout to be made by customer
- UL-certified

Note: The unit requires a 7" diameter of clearance to work with Qi-enabled phones placed in any orientation. The 3" dia cutout should be located on the worksurface at least 3.5" from any edge.

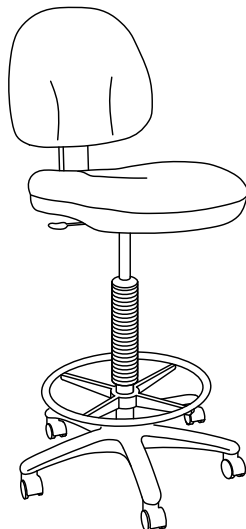

Adjustable Drafting Stool - 38202

- 40-52" height-adjustment via pneumatic cylinder
- 360° swivel
- Tilting backrest
- 18" diameter fixed foot ring
- 5-star base

Rack-mount Accessories

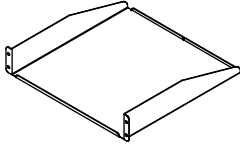

Cantilever Shelf - 2RU - 97504

- 16ga steel
- Shelf: 17.5"W [44.45 cm] x 18"D [45.7 cm] x 3.5"H [8.89 cm]
- Weight capacity: 50 lb [22.7 kg]
- Shipping weight: 8.1 lb [3.7 kg]

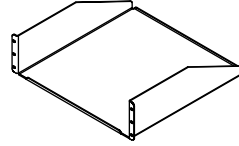

Cantilever Shelf - 3RU - 97502

- 16ga steel
- Shelf: 17.5"W [44.45 cm] x 18"D [45.7 cm] x 5.25"H [13.33 cm]
- Weight capacity: 80 lb [36.3 kg]
- Shipping weight: 9.2 lb [4.2 kg]

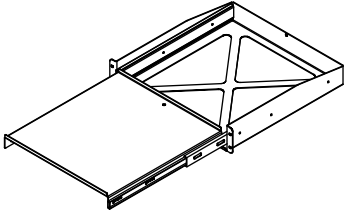

Pull-Out Shelf - 2RU - 97505

- 16ga steel
- 17.09"W [43.42 cm] x 18.12"D [46.03 cm] x 3.5"H [8.89 cm]
- Weight capacity: 50 lb [22.7 kg]
- Shipping weight: 15.6 lb [7.1 kg]

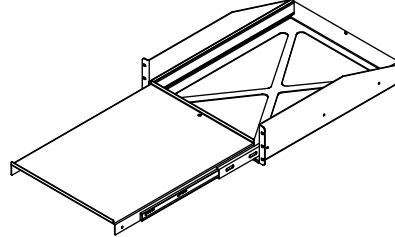

Pull-Out Shelf - 3RU - 97503

- 16ga steel
- 17.09"W [43.42 cm] x 22.11"D [56.14 cm] x 5.25"H [13.33 cm]
- Weight capacity: 80 lb [36.3 kg]
- Shipping weight: 18.5 lb [8.4 kg]

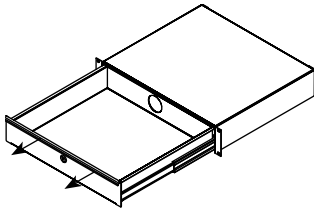

Locking Drawer - 2RU - 97523

- 16ga steel
- Drawer: 15.97"W [40.56 cm] x 14.56"D [36.98 cm] x 3"H [7.63 cm]
- Weight capacity: 50 lb [22.7 kg]
- Shipping weight: 15.85 lb [7.2 kg]

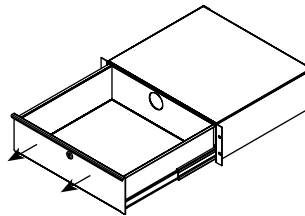

Locking Drawer - 3RU - 97522

- 16ga steel
- Drawer: 15.97"W [40.56 cm] x 14.56"D [36.98 cm] x 5.25"H [13.33 cm]
- Weight capacity: 50 lb [22.7 kg]
- Shipping weight: 18.5 lb [8.4 kg]

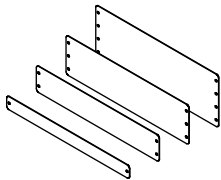

Rack-Mount Blanks

1RU - 97510 3RU - 97512
2RU - 97511 4RU - 97513

- Fills rack spaces where components are not needed
- 16 ga steel
- Shipping weight: <1 lb [45 kg]

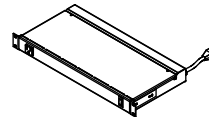

9-Outlet Power Strip - 1RU - 99021



- 8 outlets rear (breaker-protected)
- 1 convenience outlet front
- 115VAC, 60 Hz, 15 amps max
- 9' power cord
- Front LED power switch
- Enhanced surge protection
- ETL-listed, UL-listed
- 19"W [48.27 cm] x 9.25"D [23.5 cm] x 1.74"H [4.41 cm]
- Shipping weight: 8.7 lb [3.9 kg]

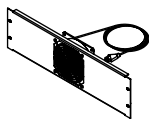

Single Fan - 3RU - 97507

- 50 cfm
- 120V~50/60 Hz, 15/13W
- RoHS
- 19"W [48.27 cm] x 1.56"D [3.97 cm] x 5.25"H [13.33 cm]
- Shipping weight: 3.78 lb [1.7 kg]

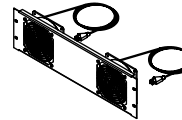

Double Fan - 3RU - 97506

- 100 cfm
- 120V~50/60 Hz, 15/13W
- RoHS
- 19"W [48.27 cm] x 1.56"D [3.97 cm] x 5.25"H [13.33 cm]
- Shipping weight: 5.47 lb [2.5 kg]



Wire Lace Kit - 95517

- Provides wire management
- Mounts to standard rack rails
- Includes (3) lace straps and mounting screws
- Includes (12) 5.5" zip ties
- Shipping weight: 1.25 lb [.57 kg]

See spectrumfurniture.com for the latest accessories and detailed warranty information.

Warranty

We will make it right for you!

Thanks for choosing Spectrum! Spectrum is committed to provide complete customer satisfaction. Each of our products is manufactured from the best materials available and each product is stringently monitored throughout the production process through our P.A.C.E. program (Product Assurance to meet Customer Expectations).

We expressly warrant that Spectrum products will be of good quality and workmanship and free from defect for the period set out in the warranty from the date of delivery.

For a listing of all product specific warranty terms please visit our website at:

<https://www.spectrumfurniture.com/en/resources/purchasing-terms-warranty>

1-800-235-1262

Toll-free HELPLINE

spectrum@spectrumfurniture.com



Spectrum Industries is Certified ISO 9001:2015