

Technical Specifications

55267	42" Flat Panel Display Cart
55268	36" Flat Panel Display Cart

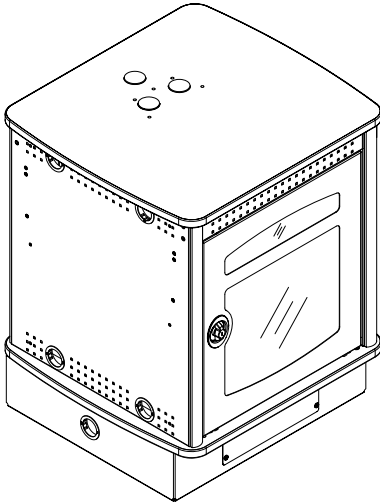

205 Westwood Ave, Long Branch, NJ 07740
 Phone: 866-94 BOARDS (26273) / (732)-222-1511
 Fax: (732)-222-7088 | E-mail: sales@touchboards.com



36" Flat Panel Display Cart V2
 55268TK
 (with toe kick)

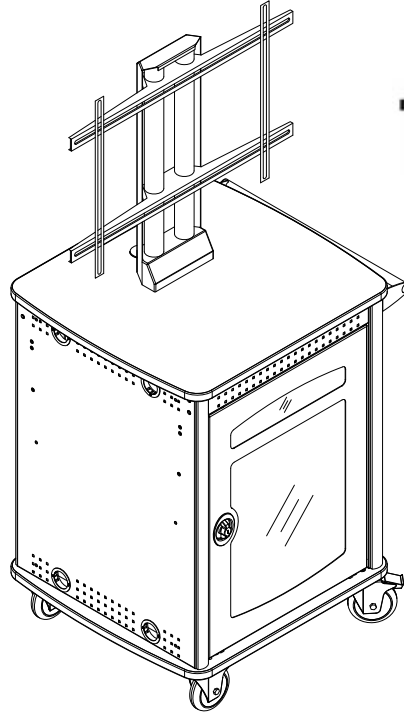

42" Flat Panel Display Cart V2
 55267SR
 (shown with optional flat screen stand)

36"H or 42"H	Size
--------------	-------------

SR - 2 rigid, 2 swivel balloon wheels (provides more control when mobile) BW - 4 swivel balloon wheels TK - Toe Kick	Base
---	-------------

Page 8	Options
--------	----------------

The Flat Panel Display Cart V2 comes standard with Spectrum's most convenient accessories. The flip-up shelf is a perfect setting for laptop placement while getting out the audience's view of the monitor. Mobility in a cart is essential, so we added an ergonomic handle and 5" smooth-riding balloon wheels. Spectrum's Flat Panel Display Cart V2 is the model of convenience to capture video streaming anywhere!

Features and Benefits

- Available in 36" or 42" heights for optimal viewing level
- Worksurface grommets provide wire and cable access
- One standard handle provides control and mobility (BWithSR models only)
- Ventilated side panels help keep equipment cool
- Removable acrylic viewing/access panel on the front door provides easy monitoring and access to internal equipment
- Double-bolt, locking doors provide security and easy-access
- Quick-release door hinges allow doors to be removed for full-access to internal equipment
- Rack-rail equipment mounting simplifies installation for any equipment configuration (42"H - 17RU, 36"H - 13RU)
- Cable grommets strategically placed throughout for effective cord management
- Four 5" locking balloon wheels roll easily and quietly on uneven surfaces
- Toe kick (TK) version available when mobility is not necessary or desired
- Durable powder coated steel chassis
- Scratch and impact-resistant 1.063" high-pressure laminate worksurface
- Optional Universal Flat Screen Stand is ANSI-BIFMA tested and accommodates screens up to 50" (diag)
- Optional flip-up shelf provides a convenient additional worksurface
- Optional rear rack rail provides additional rack units if necessary
- Optional camera shelf provides a mounting location above the screen for a video conferencing camera
- Warranted to be free of all defects in materials and workmanship with a 10-year warranty

Color Options

Standard laminate / color combinations

Wild Cherry / Black
 (CHB)



Indigo Organix / Black
 (IB)



Indigo Organix / Dark Gray
 (ID)



Fusion Maple / Black
 (FMB)



Standard color combination refers to the quickest deliverable product color combination. Custom laminates and color combinations are available-additional lead-times and up-charges may apply. Call 1-800-235-1262 for further information.

Construction

- The worksurface and base panel is constructed from 1.063" thick NAUF (no added urea formaldehyde) composite board with .030 high-pressure laminate on one face, and a balancing phenolic backer on the opposing face
- 16-gauge steel doors and side panels
- Solid wood corner trim
- Worksurface edges are covered with 3mm vinyl
- All metal components are finished with a scratch-resistant powder coat epoxy
- Each Flat Panel Display Cart is factory-assembled with casters or toe kick, packaged, and shipped on its own skid

Specifications

Total internal area	23.25"W x 22.875"D x 33.625"H (36"H) 23.25"W x 22.875"D x 27.625"H (42"H)	
Standard rack rail	<u>36"H</u> 13RU	<u>42"H</u> 17RU
5" Balloon Wheels	weight capacity 325 lbs each	
Unit weights (nominal)	<u>36"H</u> 201 lbs	<u>42"H</u> 215 lbs
Shipping weight (nominal)	<u>36"H</u> 239 lbs	<u>42"H</u> 253 lbs
Meets or exceeds applicable ANSI-BIFMA test standards		

Specifications subject to change without notice

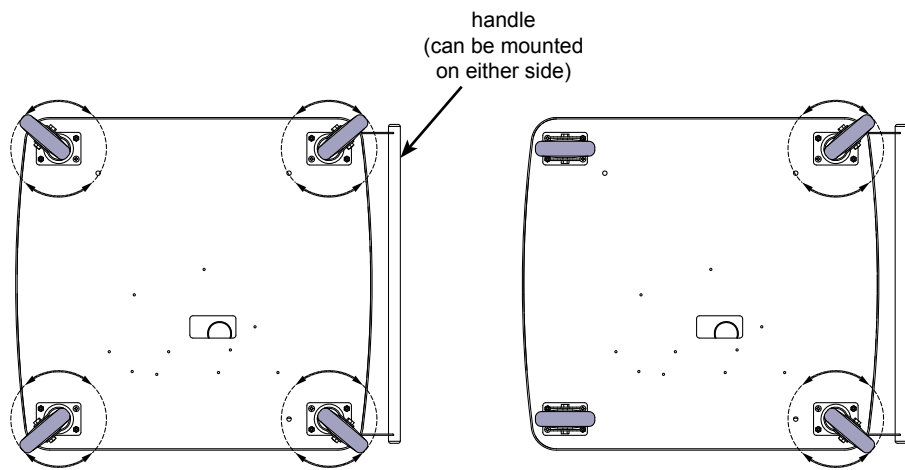

BW

5" Balloon Wheels (4 swivel)

Provides more maneuverability in tight spaces, but less control when mobile

SR

5" Balloon Wheels (2 swivel, 2 rigid)

Provides more control when mobile, but less maneuverability in tight spaces

Note: If you have the SR version on your particular cart, mounting the handle on the same side as the two swivel wheels will provide more control of the cart when mobile.

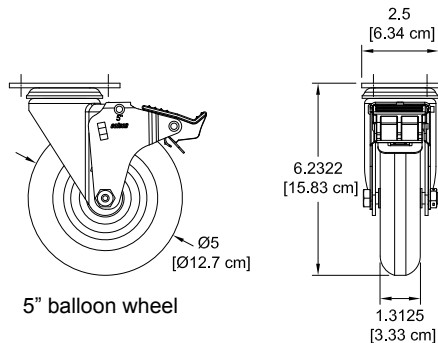

5" balloon wheel

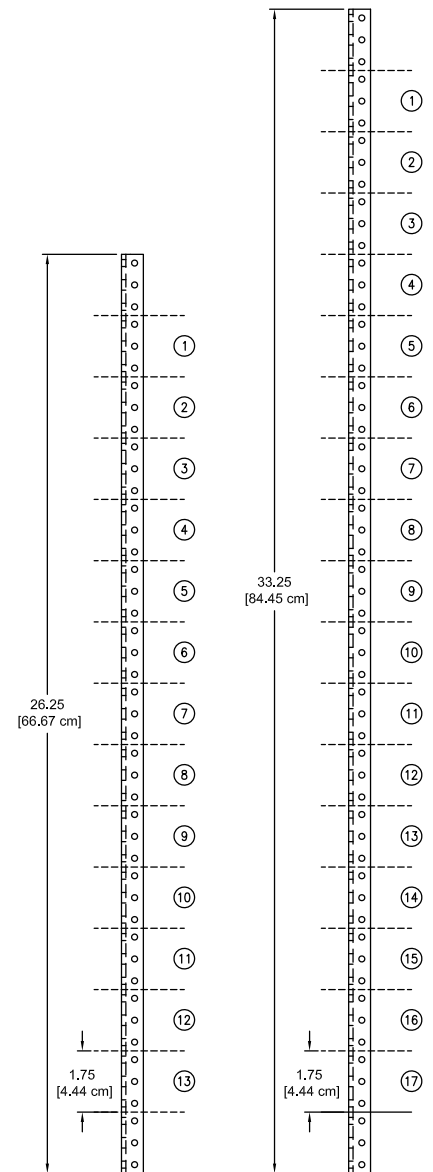

36"H Cart
13RU available

42"H Cart
17RU available

36" Flat Panel Display Cart V2
 (shown with optional Universal Flat Screen Stand)

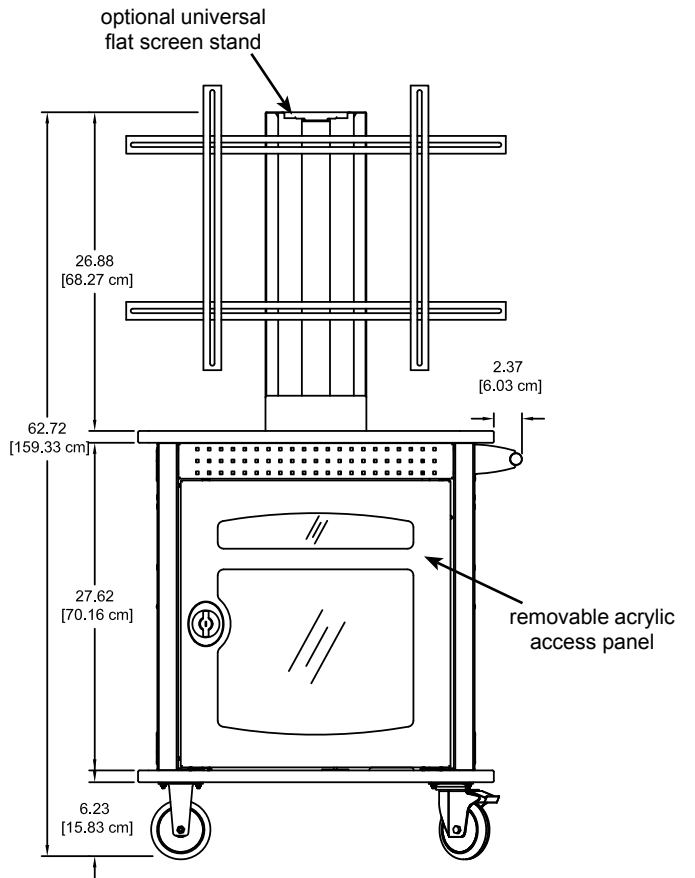
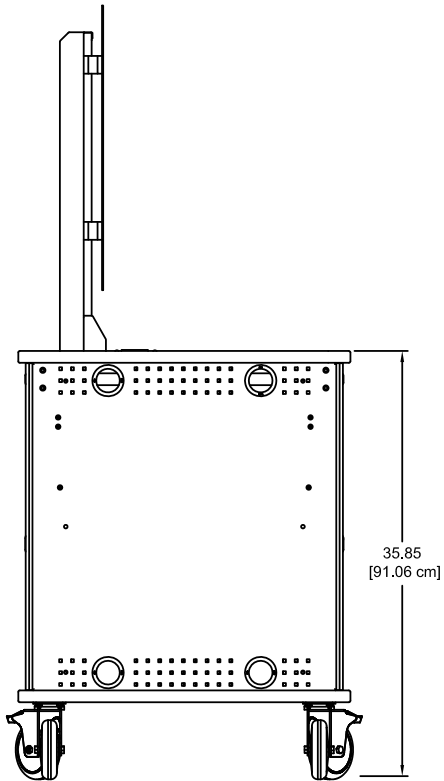
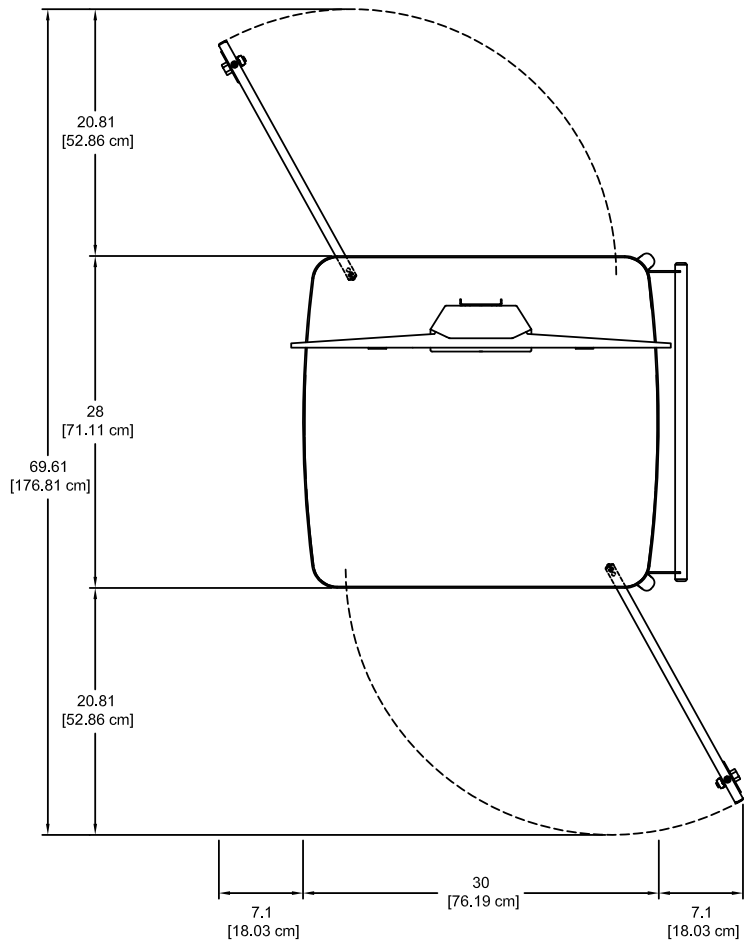
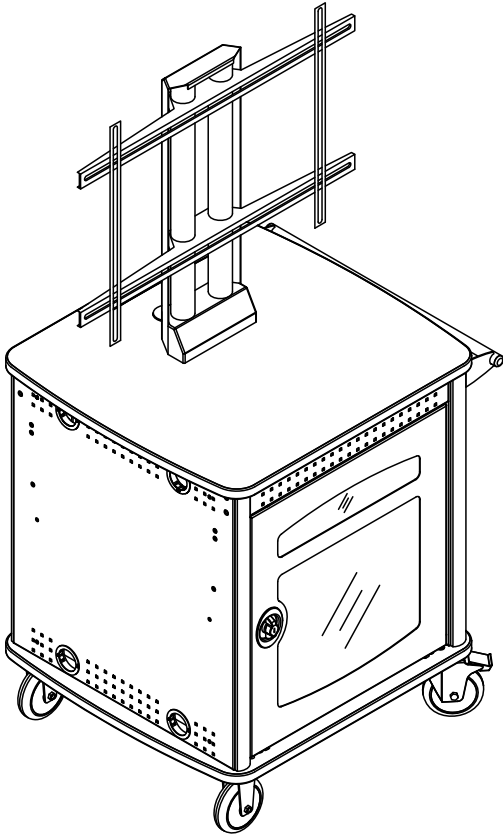

36" Flat Panel Display Cart V2
 (shown with optional Universal Flat Screen Stand)

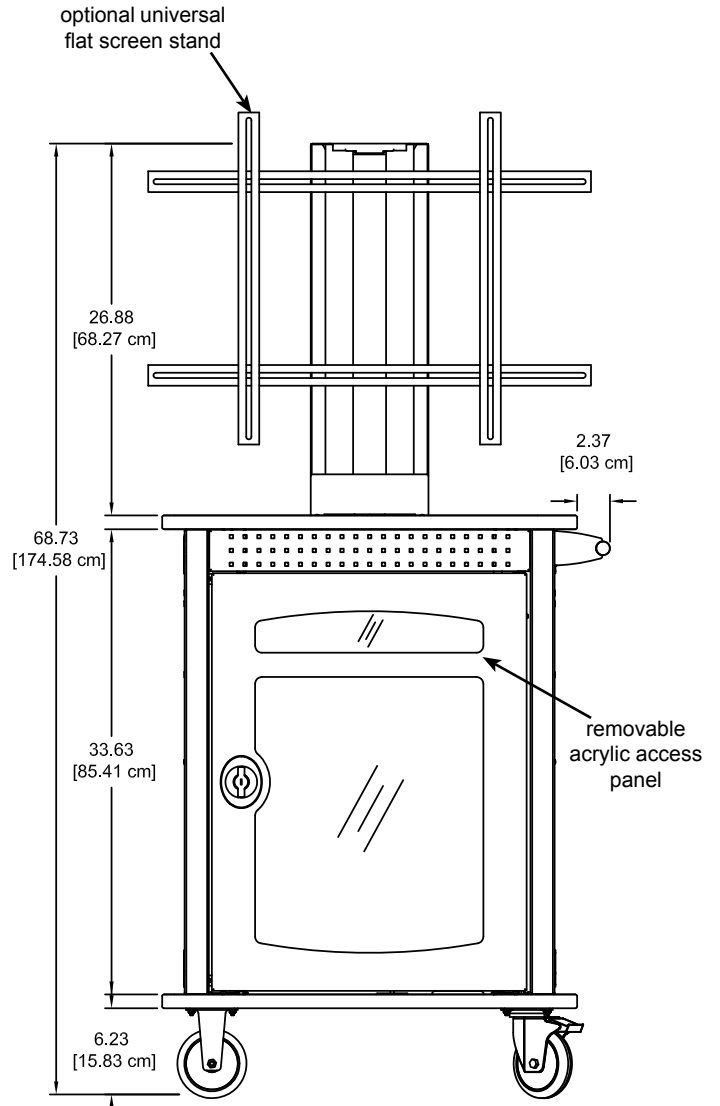
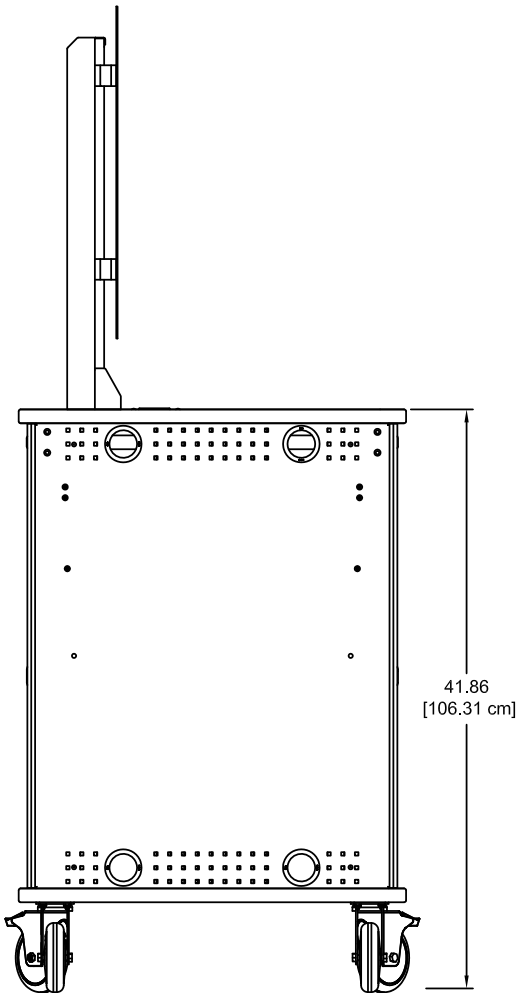
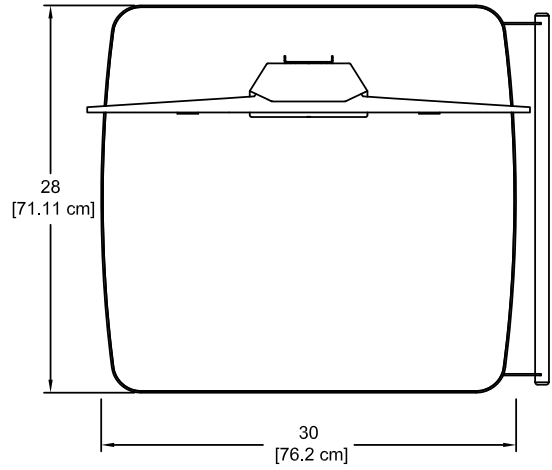
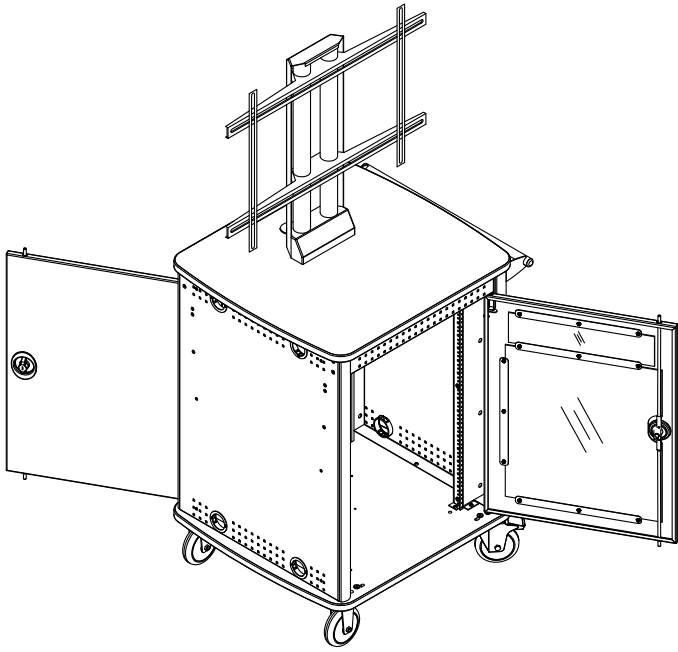

36" Flat Panel Display Cart V2 with toe kick

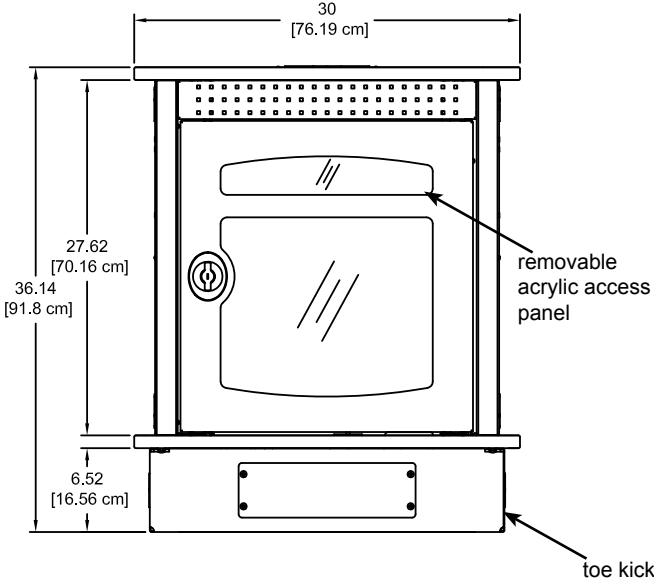
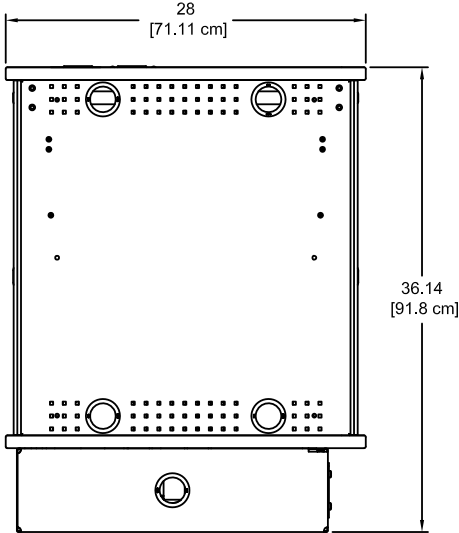

42" Flat Panel Display Cart V2 with toe kick

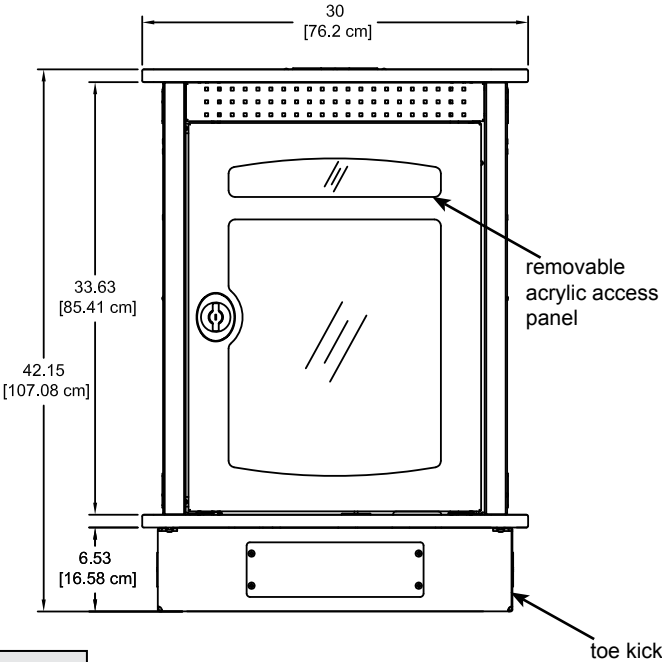
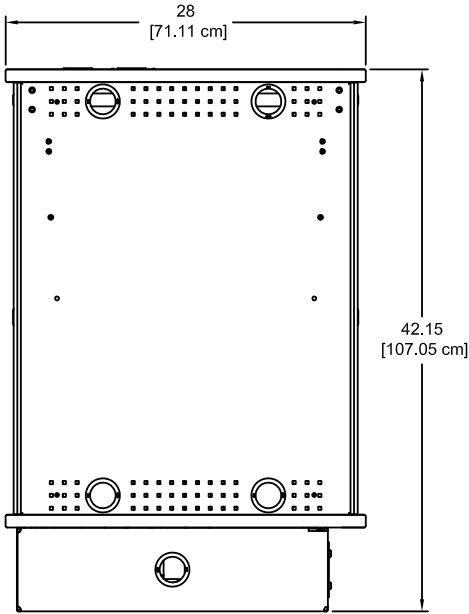

Note: Handle is not included with the toe kick version.

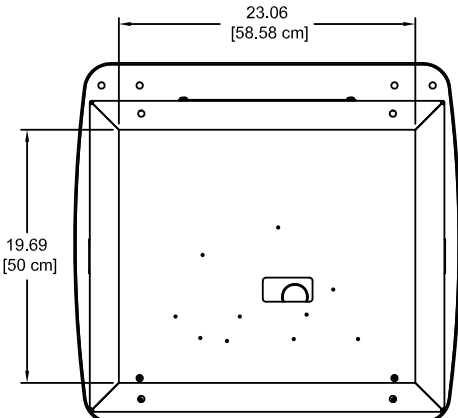
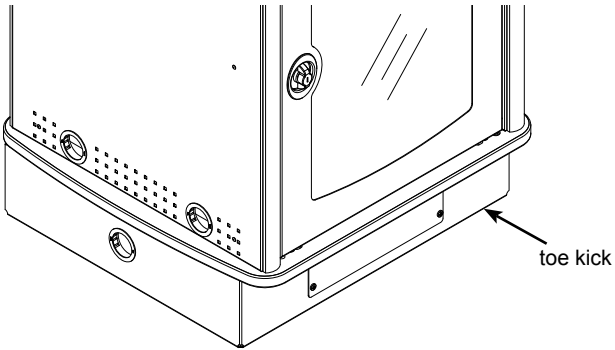

42" cart section view

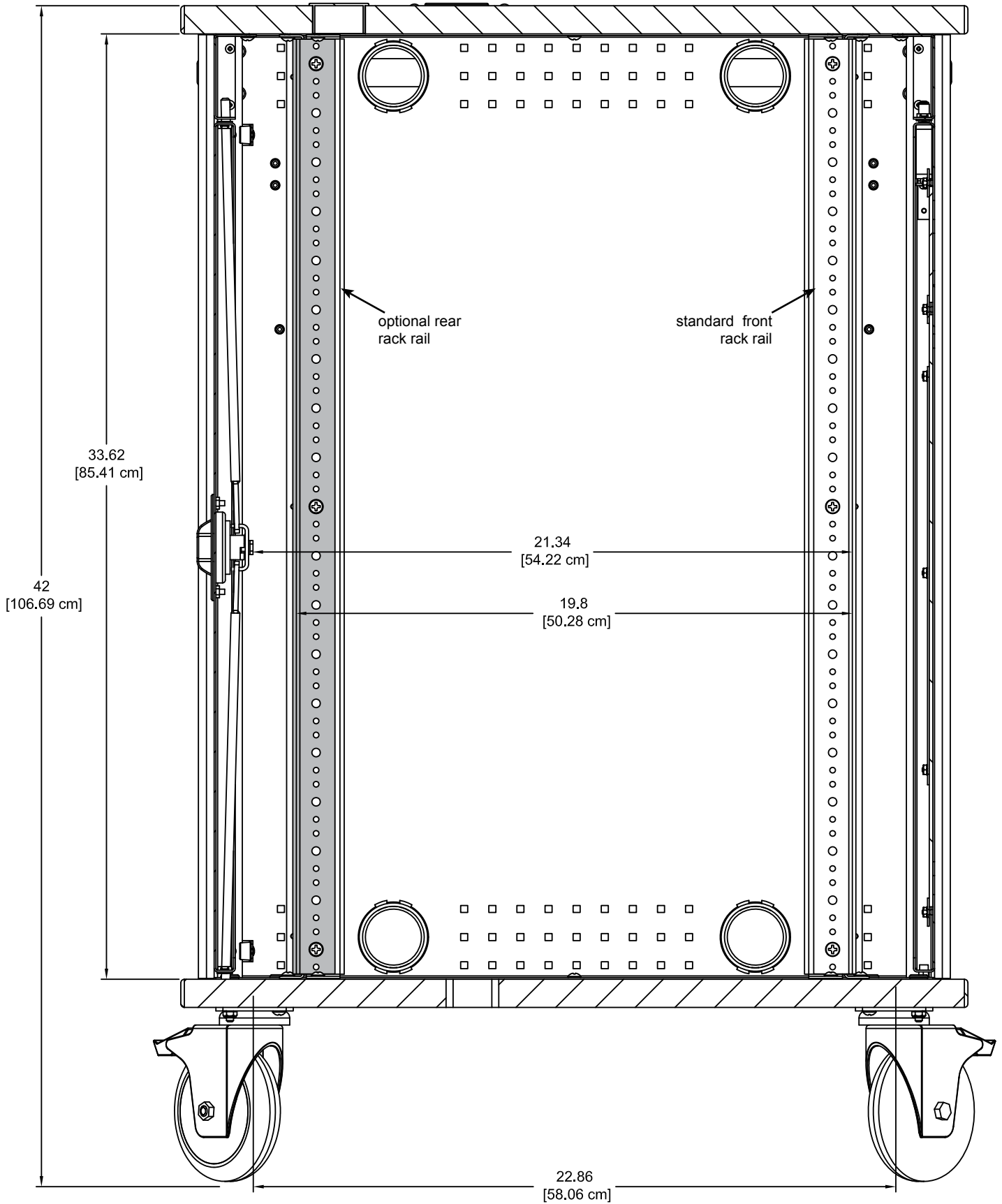

available positions on base panel for optional cord reel

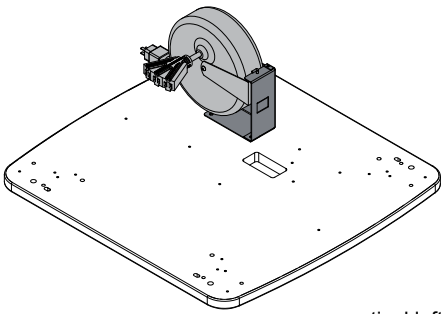

vertical left
(takes up 6RU)

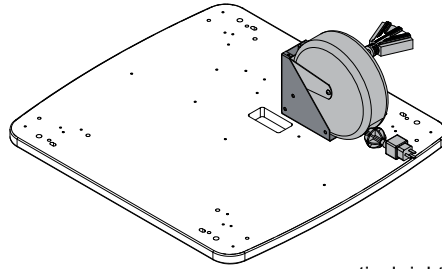

vertical right
(takes up 6RU)

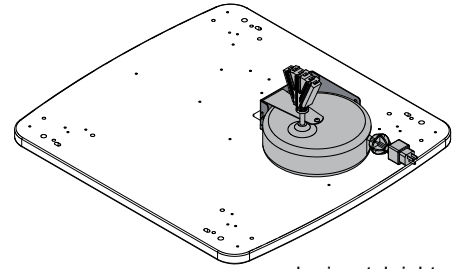

horizontal right
(takes up 3RU)

Flat Panel Display Cart with optional universal cord reel kit 99037 (available rack spacing)

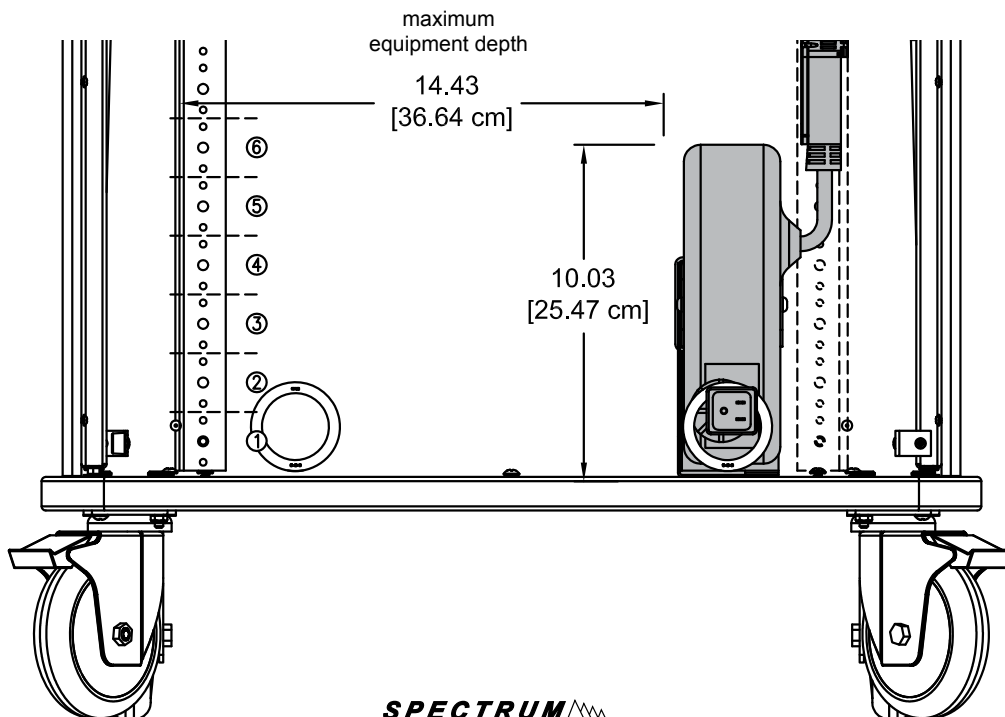
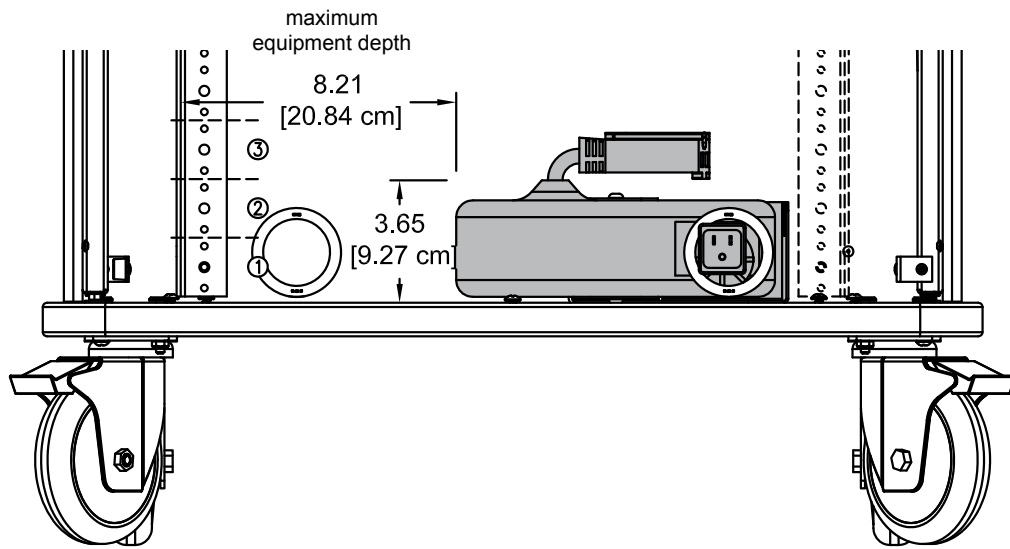

Options

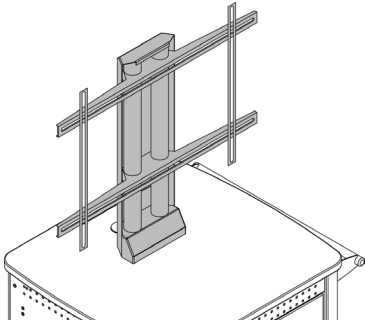

Universal flat screen stand
 bolts to work surface-holds up to a
 50" diagonal flat screen
 Total weight not to exceed 160 lbs
 55278

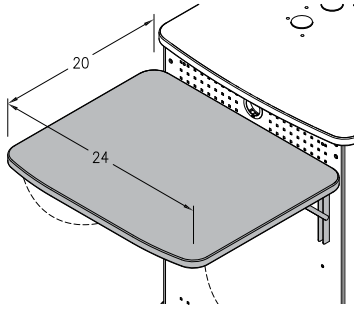

Flip-up shelf
 mounts on left or right, (max 2 per unit)
 20"W x 24"D x 1" thick
 (50 lbs max capacity)
 55273

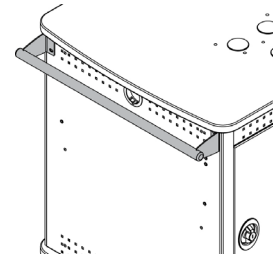

Steel handle
 mounts on left or right-
 max 2 per unit
 55265



Custom-cut logo
 (Typical logo location-on rear door)
 55141

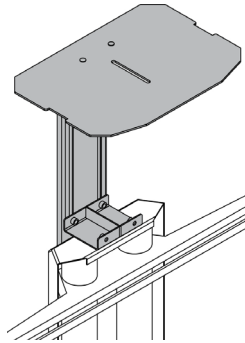

Video conferencing camera shelf
 attaches to top of universal flat screen stand 55278
 shelf size: 11.5"W x 8.5"D
 (adjusts vertically 6.875")
 55282

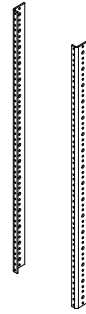

Rear rack rail kit
 36" (13 RU) - 55275
 42" (17 RU) - 55274

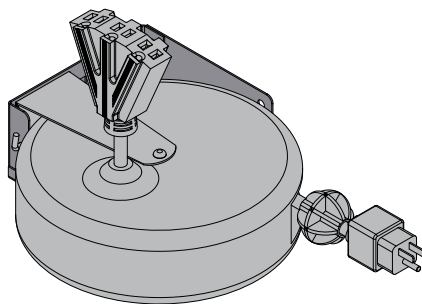

Universal Cord Reel Kit
 15' [457.2 cm] retractable, 12 AWG, with
 breaker, includes universal mounting bracket
 (mounts horizontally or vertically inside
 lectern to base panel) 10 lbs [.45 kg]
 99037



Note: When installed, the cord
 reel takes up rack units from
 the bottom of the rack rail.

Horizontal installation: 3RU
 Vertical installation: 6RU

⚠ The cord reel is intended to provide temporary access to electrical outlets for
 Spectrum mobile lecterns. Check local electrical codes prior to installation.

Rack-mount accessories

Note: Rack-mount accessories with a depth greater than 21.3125"D will not fit in the Flat Panel Display Cart. Check the dimensions of all equipment before installation. The following Spectrum rack-mount accessories will not fit:

97503 - Pull-out Shelf (3RU)

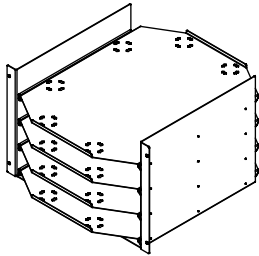

LT-4 Laptop Storage Unit (7RU)
 (stores 4 laptops horizontally)
 laptop tray dims:
 16.25"W x 20.5"D x 2.1875"H
 97517

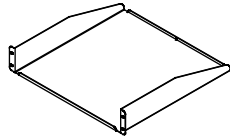

Cantilever Shelf (2RU)
 17.5"W x 18"D x 3.5"H
 (50 lbs max load)
 97504

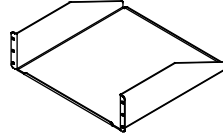

Cantilever Shelf (3RU)
 17.5"W x 18"D x 5.25"H
 (80 lbs max load)
 97502

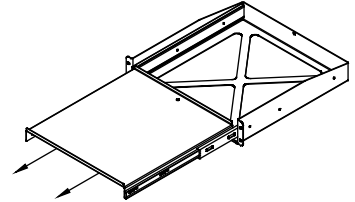

Pull-Out Shelf (2RU)
 16.5"W x 17.75"D
 (50 lbs max load)
 97505

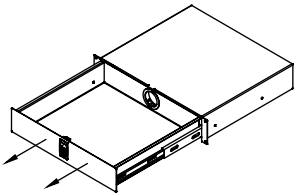

Locking Drawer (2RU)
 interior dims:
 15.75"W x 13.6875"D x 2.875"H
 (25 lbs max load)
 97514

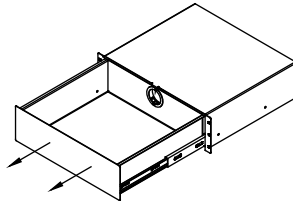

Drawer (3RU)
 interior dims:
 15.9375"W x 14.5"D x 5.25"H
 (50 lbs max load)
 97518

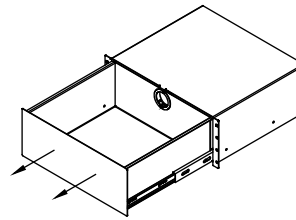

Drawer (4RU)
 interior dims:
 15.9375"W x 14.5"D x 7"H
 (50 lbs max load)
 97519

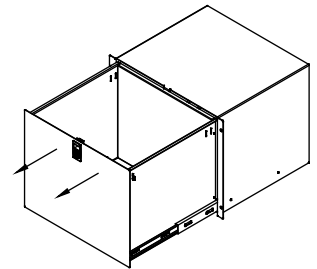

Locking File Drawer (8RU)
 with file holder
 interior dims:
 15.75"W x 13.5625"D x
 13.3125"H
 (50 lbs max load)
 97515

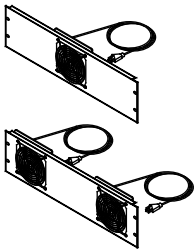

Cooling Fans (3RU)
 19"W x 2"D x 5.25"H
 Single Fan-97507
 Double Fan-97506

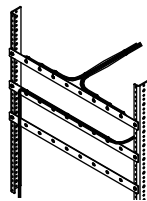

Wire Lace Kit
 3 lace straps included
 95517

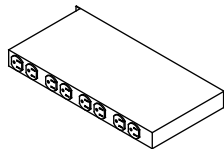

9-Outlet Power Strip (1RU)
 19"W x 9"D x 1.75"H
 99021

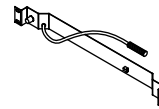

Flexible Halogen Light (1RU)
 19"W x 2"D x 1.75"H
 99033

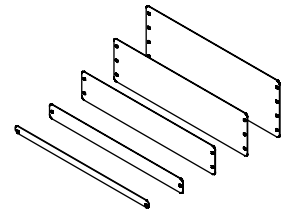

Rack-Mount Blanks
 (fills rack spaces where components are not needed)
 97516 - (½ RU)
 97510 - (1RU)
 97511 - (2RU)
 97512 - (3RU)
 97513 - (4RU)

Warranty

WE WILL MAKE IT RIGHT FOR YOU!

Spectrum is committed to provide complete customer satisfaction. Each of our products is manufactured from the best materials available and each product is stringently monitored throughout the production process through our P.A.C.E. program (Product Assurance to meet Customer Expectations).

We expressly warrant that Spectrum products will be of good quality and workmanship and free from defect for the period set out in the warranty table below from the date of delivery. This warranty shall not apply to defects or damage resulting from misuse, abuse, neglect, improper care, modification or repair not authorized by Spectrum, or any other cause outside the control of Spectrum. Spectrum will, at its sole option, either repair or replace the defective product.

This warranty is exclusive; no other warranty, written or oral, is expressed or implied. This warranty is given by Spectrum to Buyer and to no other person or legal entity. No Spectrum dealer, distributor, agent or employee is authorized to make any modification or addition to this warranty.

NOTWITHSTANDING ANYTHING TO THE CONTRARY, SPECTRUM WILL NOT UNDER ANY CIRCUMSTANCES BE LIABLE FOR INDIRECT OR LIQUIDATED DAMAGES, INCLUDING CONSEQUENTIAL, INCIDENTAL AND SPECIAL DAMAGES. IN NO EVENT SHALL SPECTRUM'S LIABILITY, WHETHER UNDER CONTRACT OR WARRANTY, IN TORT OR OTHERWISE, EXCEED THE PURCHASE PRICE RECEIVED BY SPECTRUM FOR THE PRODUCT AT ISSUE AND "RECALL ACTION" EXPENSES. SPECTRUM SHALL NOT BE SUBJECT TO ANY OTHER OBLIGATIONS OR LIABILITIES, WHETHER ARISING OUT OF BREACH OF CONTRACT, WARRANTY, TORT (INCLUDING NEGLIGENCE AND STRICT LIABILITY) OR OTHER THEORIES OF LAW, WITH RESPECT TO PRODUCTS SOLD OR SERVICES RENDERED BY SPECTRUM, OR ANY UNDERTAKINGS, ACTS OR OMISSIONS RELATING THERETO.

Our Customer Service Department is ready to provide immediate attention to any questions, comments or concerns. They are available to answer your calls Monday through Friday from 7 am to 5 pm CST. In addition your product comments or concerns are welcome via e-mail at: spectrum@spectrumfurniture.com.

Warranty Table

Item	Warranty Period
<ul style="list-style-type: none"> Adjustable Crank/Electric Desk Legs Flat Panel Desk Gas Cylinders 	<ul style="list-style-type: none"> 1 Year
<ul style="list-style-type: none"> Adjustable Height Chair Parts – including frames, gas cylinders, wood and plastic parts, and control handles Adjustable Height Chair Parts Casters Adjustable Height Chair Upholstery In-Stock Upholstery Graded-In Fabrics and Customer Owned Material 	<ul style="list-style-type: none"> 7 Years 2 Years 2 Years No Warranty
<ul style="list-style-type: none"> Height Adjustable Columns and Lifts General Use Casters Electrical Keyboard/Mouse Trays 	<ul style="list-style-type: none"> 1 Year
<ul style="list-style-type: none"> Flat Panel Monitor Arm – General Parts Flat Panel Monitor Arm – Gas Cylinders 	<ul style="list-style-type: none"> 5 Years 2 Years
<ul style="list-style-type: none"> Computer Desk Chassis Cart Chassis Lectern Chassis 	<ul style="list-style-type: none"> 10 Years



205 Westwood Ave, Long Branch, NJ 07740
 Phone: 866-94 BOARDS (26273) / (732)-222-1511
 Fax: (732)-222-7088 | E-mail: sales@touchboards.com



925 First Avenue, PO Box 400, Chippewa Falls, WI 54729 Ph: 800-235-1262, 715-723-6750 Fax: 800-335-0473, 715-738-2309

E-mail: spectrum@spectrumfurniture.com web: www.spectrumfurniture.com