

Flat Panel Display Cart V2™

55267	42" Flat Panel Display Cart
55268	36" Flat Panel Display Cart

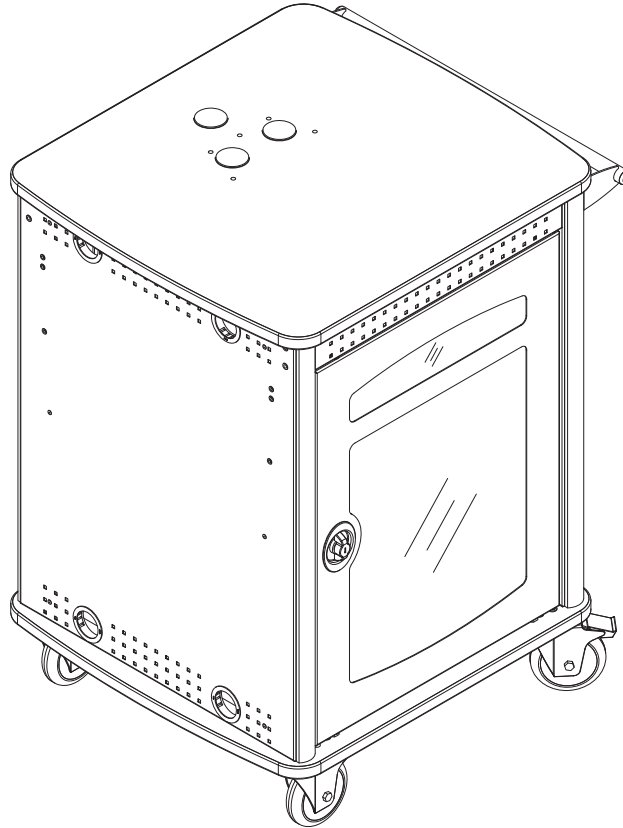

205 Westwood Ave, Long Branch, NJ 07740
Phone: 866-94 BOARDS (26273) / (732)-222-1511
Fax: (732)-222-7088 | E-mail: sales@touchboards.com



⚠ Important ⚠

Before using this product:

- Read this manual
- Comply with all safety and operating instructions
- Ensure all parts and correct quantities are included

Any parts damaged during shipment must be reported within 15 days of receipt. To report information regarding missing parts or damage, to purchase parts or accessories, or if you have any questions, please contact us.

Thank you for purchasing Spectrum products!

Spectrum product page:
<http://bit.ly/FPDcart>



Spectrum Industries, Inc
925 First Avenue, Chippewa Falls, WI 54729 USA
800 235 1262
715 723 6750
www.spectrumfurniture.com

⚠ Important Safety and Care Instructions ⚠

- Read this owner's manual before assembly or operation.
- Do not allow children to move the cart.
- Proceed slowly and carefully when moving the cart.
- For indoor use only. Do not install or store the cart where it will be exposed to moisture.
- Do not block the ventilation openings.
- Avoid uneven loading of the equipment into the cart. Uneven weight distribution could cause the cart to tip when the cart is moving.
- Do not allow anyone to sit, stand, or climb on the cart.
- Use a damp, soft-cloth, or sponge, with mild soap or detergent solution to clean dirty surfaces. Do not use harsh solvents or abrasives.
- This cart is intended for institutional use. It does not have any user-serviceable parts or user-maintenance requirements. If servicing is necessary, please contact Spectrum Industries for assistance.

⚠ Warning - Relocating audio and/or video equipment to furniture not specifically designed to support audio and/or video equipment may result in death or serious injury due to the furnishing collapsing or over turning onto a child.

⚠ Warning - Death or serious injury may occur when children climb on audio and/or video equipment furniture. A remote control or toys placed on the furnishing may encourage a child to climb on the furnishing and as a result the furnishing may tip over on to the child.

Electrical Safety:

- Keep the power switch in the OFF position before plugging or unplugging from the wall outlet.
- Turn OFF the devices before plugging them into the cart.
- Ensure total device / equipment load does not exceed 12-amps.
- Do not plug the power cord into an extension cord.
- Inspect the power cords for damage before each use. Do not use power cords that are damaged.
- Unplug power cord from electrical outlet by gripping the cord. Do not unplug the power cord by pulling only on the cord.
- Do not step on, drive over, drag, or place objects on the power cord.
- For added safety, plug the cart into a grounded outlet controlled by a GFI (Ground Fault Interrupter) circuit breaker.
- Damaged electrical components can create significant hazards to users and is not covered by the warranty. Repairs should always be performed by a qualified electrician.
- Electrical devices are not toys. Children are often unaware of the hazards associated with electrical devices. This cart must always be used by adults or with adult supervision.

Hardware Package Contents



(5) 0102786
M5 x 40mm PHMS



(5) 026059
1/4" flat steel washer



(4) 052605
1/4-20 x 15mm JC bolts

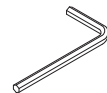

(1) 025039
4mm hex wrench

Attach handle

1. Determine which side of the cart you want the handle to be on.
2. Attach the handle to the cart side panel with (4) 1/4-20 x 15mm JC bolts. **Figure 1.**
3. Tighten all JC bolts securely.
4. The power cord can be wrapped around the handle when not in use. **Figure 2.**

Tools Required		4mm hex wrench (included)

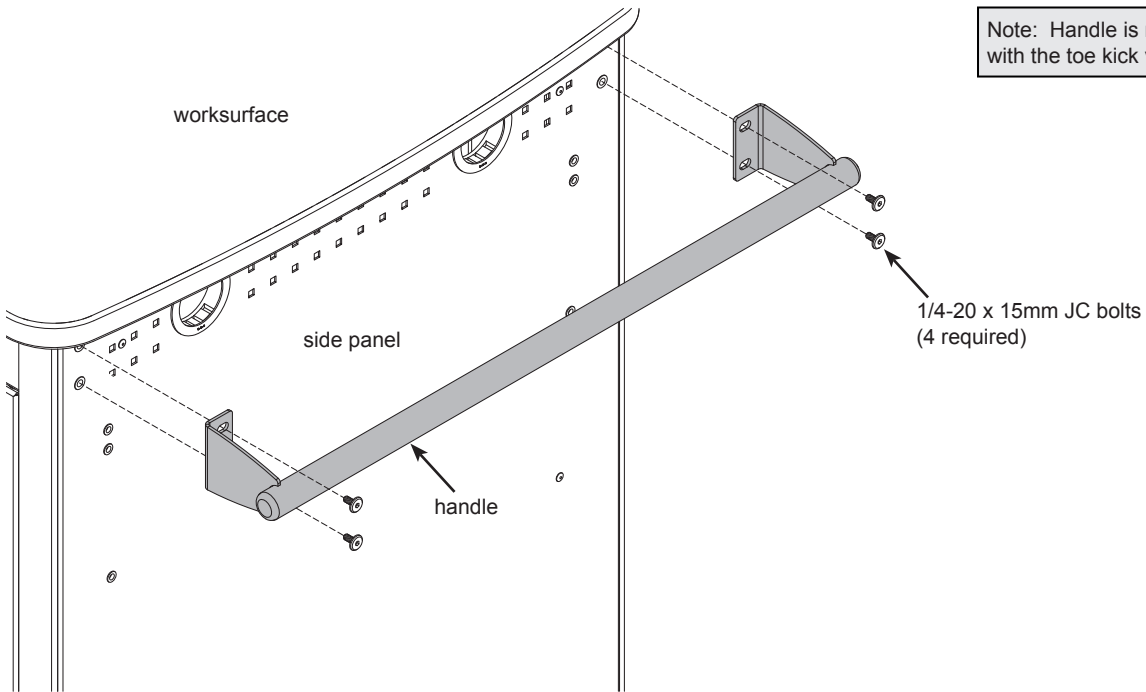

Figure 1

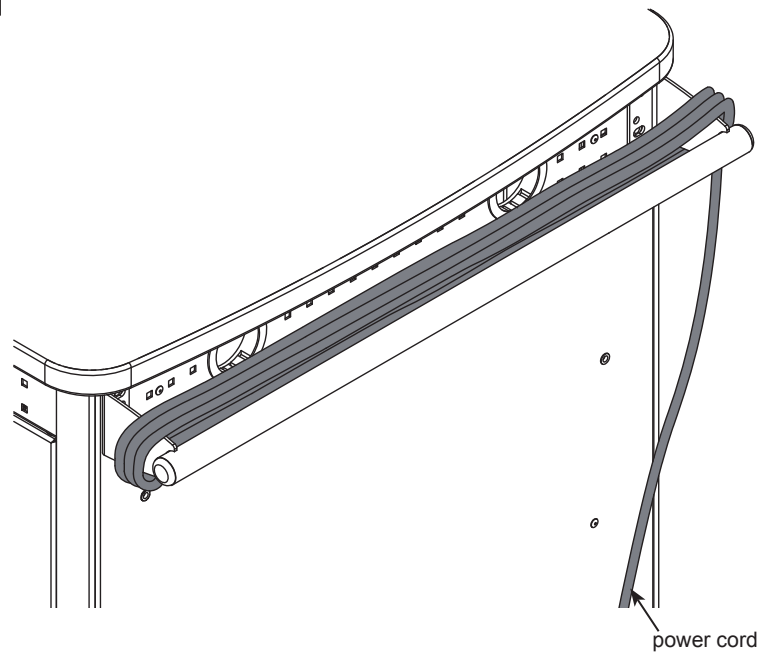

Figure 2

Attach universal flat screen stand base - optional

Note: If you have not purchased the Universal Flat Screen Stand option, you can disregard this step. The aluminum base included with the stand will mount directly to the worksurface.

The black MDF base included with the Universal Flat Screen Stand is only used in stationary, non-mobile applications and is not needed or recommended on a cart installation. Do not install the black MDF base onto the cart.



Touchboards

205 Westwood Ave, Long Branch, NJ 07740
Phone: 866-94 BOARDS (26273) / (732)-222-1511
Fax: (732)-222-7088 | E-mail: sales@touchboards.com

1. Remove the five small hole plugs, and two front grommets and sleeves from the worksurface.
2. Open the rear door.
3. Using (5) M5 x 40mm PHM screws and 1/4" washers, attach the aluminum base included with the universal LCD stand to the worksurface as shown. **Figure 3**. Tighten all of the screws equally and securely.
4. At this point, refer to the manufacturer's instructions to proceed with the remaining stand assembly.

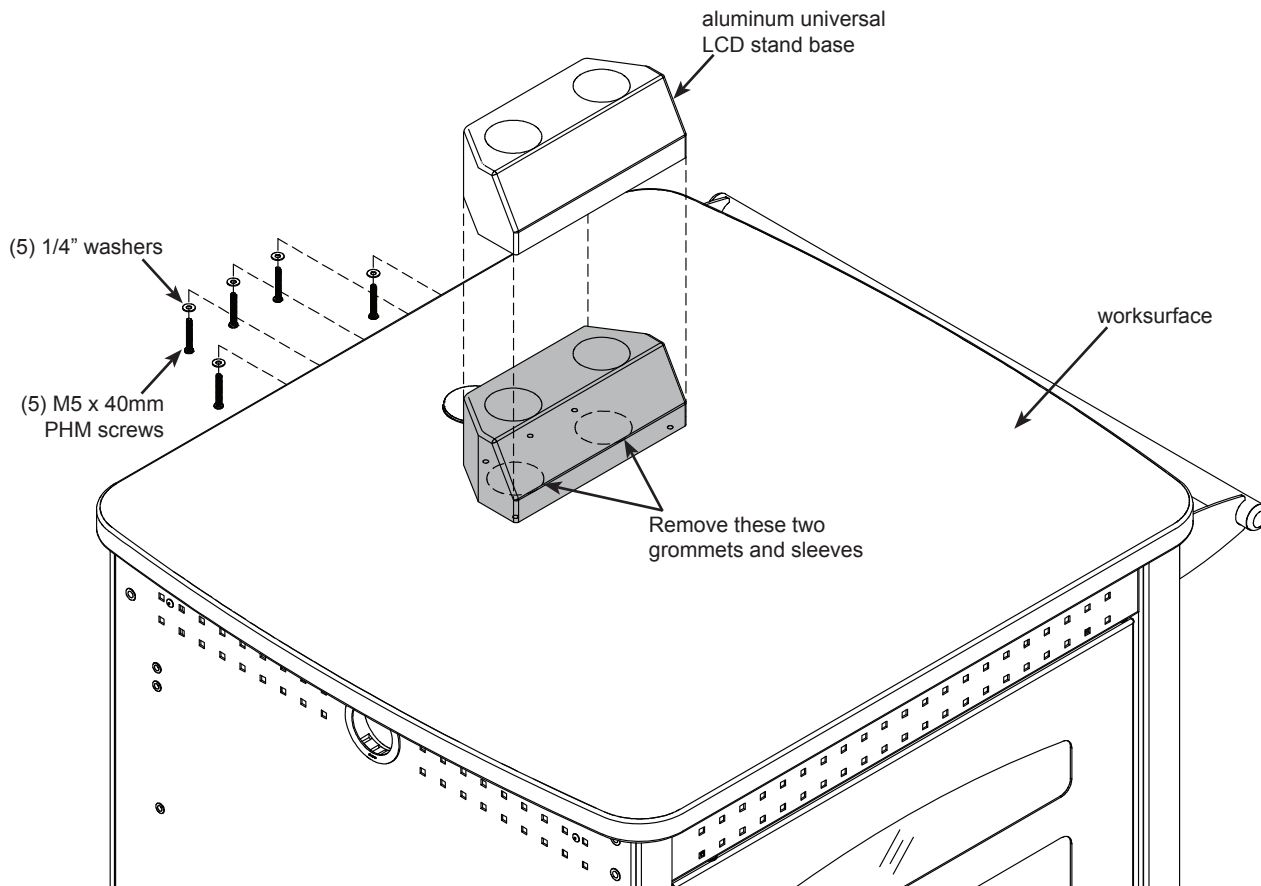

Figure 3



The Universal Flat Screen Stand accommodates flat panel display screens and monitors up to 50" (diag) and up to 160 lbs. Do not exceed these ratings.

Quick-release door hinge operation

The front and rear doors can easily be removed for equipment installation.

1. To remove door, pull down the quick-release lever as shown in **Figure 4A** while removing the door.
2. To re-attach the door, pull down the quick-release lever while inserting the door hinge pins into the hinge pin holes. **Figure 4**. Release the lever when the upper hinge pin is aligned with the upper hinge pin hole-this will secure the door.

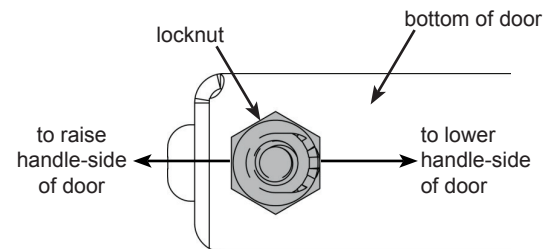
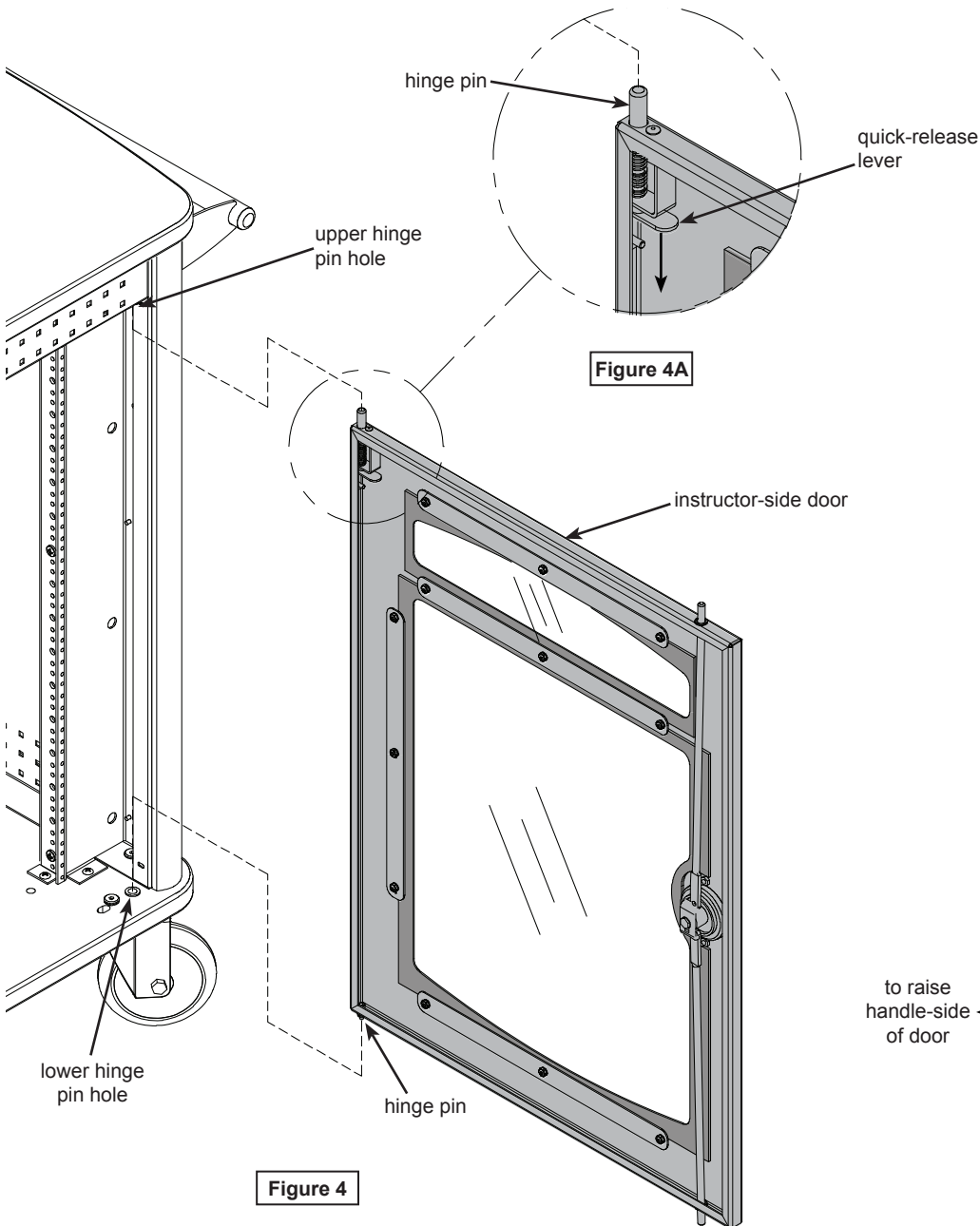

Door Alignment Procedure:

If the door appears to be misaligned, a slight adjustment can be made to the bottom hinge-side of the door. **Figure 4B**.

1. Using the quick-release lever, remove the door.
2. Set the removed door on a non-abrasive worksurface.
3. Slightly loosen the nylon locknut on the bottom corner of the door with a 3/8" or adjustable wrench and Phillips screwdriver.
4. Reposition the locknut and screw on the bottom of the door as required:
 - a. Move nut and screw away from the handle-side of the door to raise the handle-side of the door.
 - b. Move nut and screw toward the handle-side of the door to lower the handle-side of the door.
5. After adjustment, be sure the locknut is tightened securely.
6. Reinstall door and check alignment.
7. Repeat this procedure if necessary.

Floor anchoring (Toe Kick versions only)



1. If your Flat panel display cart is equipped with a toe kick, and you wish to attach it to the floor, the toe-kick will need to be detached from the cart. To detach, open the doors and remove the (4) 1/4-20 x 40mm JC bolts (one on each corner) from inside the cart. **Figure 5.** (Save these fasteners).
2. Carefully lift the cart off the toe kick and set aside. This will require several people. **Figure 6.**
3. Determine and locate the toe kick into its final position on the floor and mark the (4) mounting hole locations on the floor. (The toe kick mounting holes are 1/2" dia.)
4. Drill suitable holes into the floor and anchor the toe kick with appropriate fasteners.
5. Carefully lift the cart back onto the toe kick and align the (4) mounting holes.
6. Re-attach the cart to the toe kick with the previously removed JC bolts.
7. The access panel can be removed to access wiring below the cart.

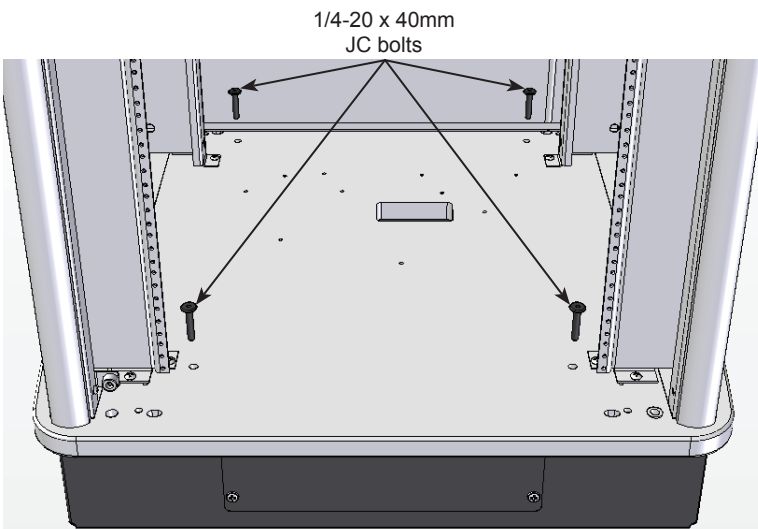

Figure 5

Note: (4) fasteners are required to anchor the toe kick to the floor. Due to the wide variety of flooring materials and conditions possible, anchor fasteners are not provided.

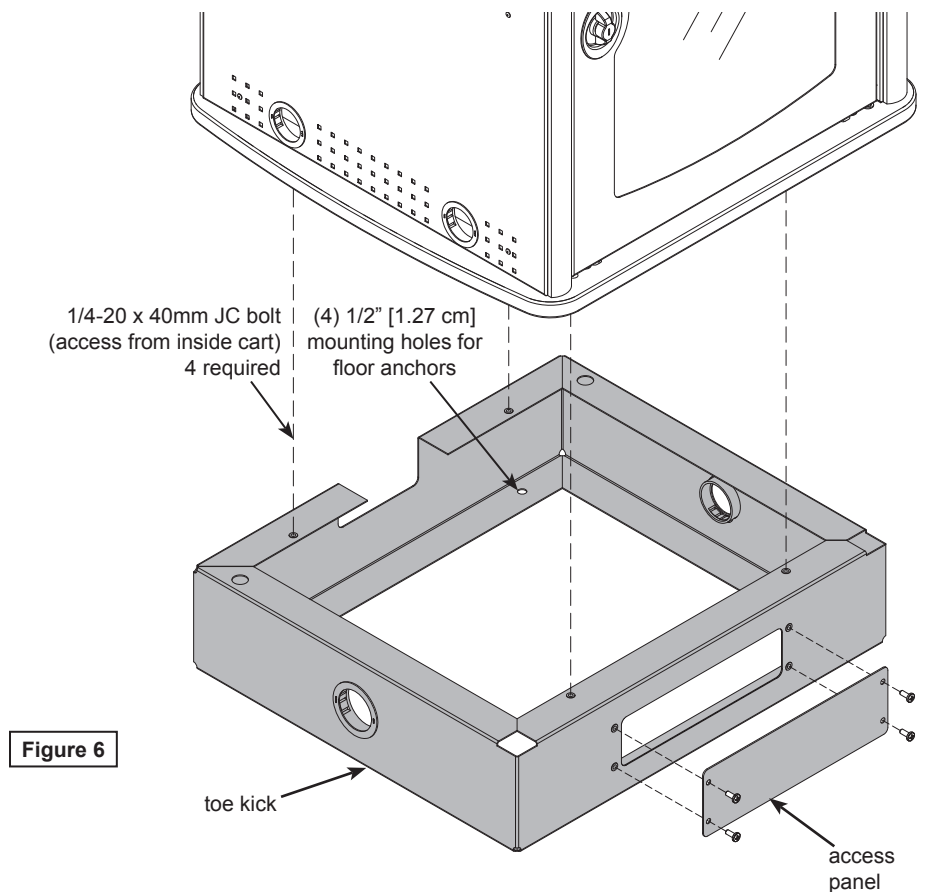

Figure 6

Door stop adjustment

If necessary, the door stops can be repositioned to adjust the closed position of the doors and lock rods.

1. To reposition the stop, loosen the Phillips screw slightly with a screwdriver. **Figure 7.**
2. Move the stop forward or backward then retighten and check the closed position of the door.
3. Repeat this process until the door and lock rods are aligned.

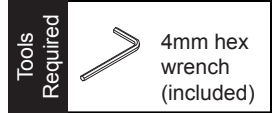
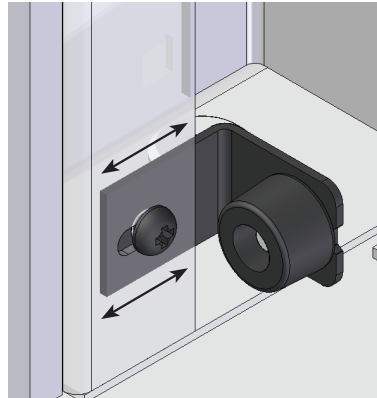

Figure 7

Wheel operation

1. To lock the wheel rotation, press the brake lever. **Figure 8.**
2. To resume operation, lift up on brake lever.

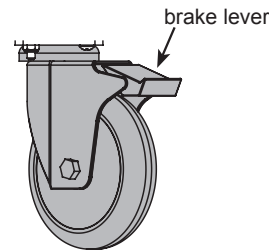

Figure 8

Moving and parking the cart

- Before moving, unplug and secure all power cords.
- Close and lock doors.
- Remove any items from the top of the worksurface.
- Unlock the wheels.
- Push slowly and carefully. Do not move over uneven or irregular surfaces.
- Do not allow children to move.
- Lock the wheels after moving.
- Do not park unit in areas of heavy traffic.
- Do not run power cords across hallways, classrooms, or other areas where they will be walked on.
- Do not leave unit unattended in areas where children have access.
- Keep doors closed and locked whenever unit is unattended or parked.
- Keep wheels locked whenever the cart is unattended.



**WARNING
ATTENTION**









CAN TIP OVER RESULTING IN RISK OF INJURY, DO NOT ALLOW CHILDREN UNDER 16 TO MOVE CART. MOVE CART SLOWLY.

PEUT BASCULER, ENTRAINANT UN RISQUE DE BLESSURE, NE LAISSEZ PAS LES ENFANTS DO MOINS DE 16 POUR DEPLACER PANIER. DEPLACER PANIER LENTEMENT

ONLY ADULTS SHOULD MOVE THIS UNIT

SEULS LES ADULTES DEVRAIENT PASSER CET APPAREIL

APPLY MOVING FORCE ON NARROW DIMENSION

APPLIQUER UNE FORCE EN MOUVEMENT SUR LA DIMENSION

NEVER APPLY FORCE AT TOP ALWAYS PUSH NEAR MIDDLE

JAMAIS EMPLOYER LA FORCE EN HAUT TOUJOURS POUSSER PRES DU MILIEU

PUSH, DO NOT PULL

POUSSER, NE TIREZ PAS

Options

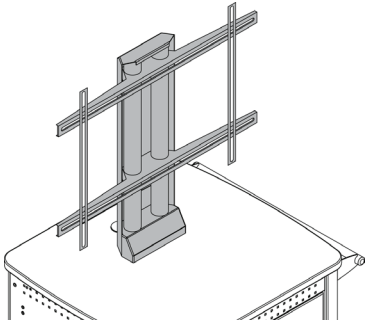

Universal flat screen stand
bolts to work surface-holds up to a
50" diagonal flat screen
55278

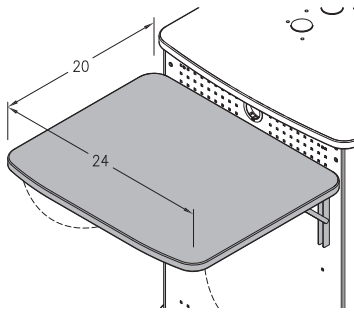

Flip-up shelf
mounts on left or right, (max 2 per unit)
20"W x 24"D x 1" thick
(50 lbs max capacity)
55273

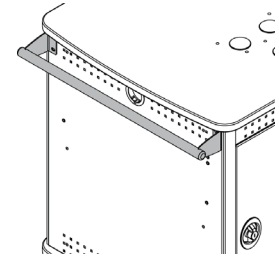

Steel handle
mounts on left or right-
max 2 per unit
55265



Custom-cut logo
(Typical logo location-on rear door)
55141

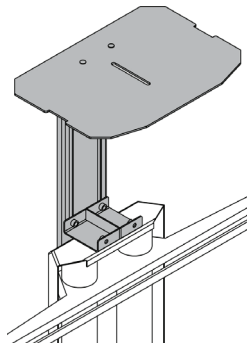

Video conferencing camera shelf
attaches to top of universal flat screen stand 55278
shelf size: 11½"W x 8½"D
(adjusts vertically 6⅞")
55282

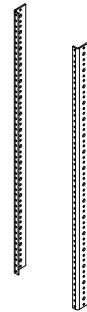

Rear rack rail kit
36" (13 RU) - 55275
42" (17 RU) - 55274

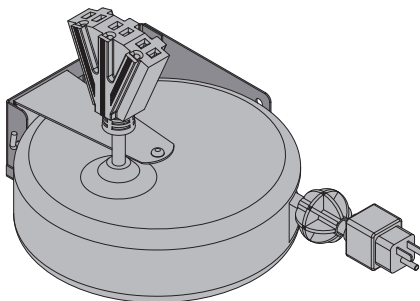

Universal Cord Reel Kit
15' [457.2 cm] retractable, 12 AWG, with
breaker, includes universal mounting bracket
(mounts horizontally or vertically inside
lectern to base panel) 10 lbs [.45 kg]
99037



Note: When installed, the cord
reel takes up rack units from
the bottom of the rack rail.

Horizontal installation: 3RU
Vertical installation: 6RU

! The cord reel is intended to provide temporary access to electrical outlets for
Spectrum mobile lecterns. Check local electrical codes prior to installation.

Rack-mount accessories

Note: Rack-mount accessories with a depth greater than $21\frac{5}{16}"$ D will not fit in the Flat Panel Display Cart. Check the dimensions of all equipment before installation. The following Spectrum rack-mount accessories will not fit:

97503 - Pull-out Shelf (3RU)

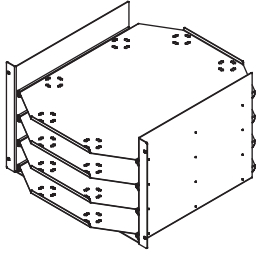

LT-4 Laptop Storage Unit (7RU)
 (stores 4 laptops horizontally)
 laptop tray dims:
 $16\frac{1}{4}"$ W x $20\frac{1}{2}"$ D x $2\frac{3}{16}"$ H
 97517

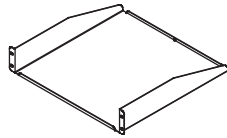

Cantilever Shelf (2RU)
 $17\frac{1}{2}"$ W x $18"$ D x $3\frac{1}{2}"$ H
 (50 lbs max load)
 97504

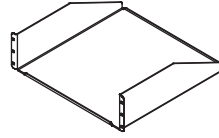

Cantilever Shelf (3RU)
 $17\frac{1}{2}"$ W x $18"$ D x $5\frac{1}{4}"$ H
 (80 lbs max load)
 97502

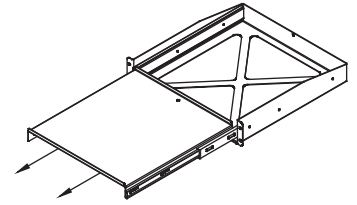

Pull-Out Shelf (2RU)
 $16\frac{1}{2}"$ W x $17\frac{3}{4}"$ D
 (50 lbs max load)
 97505

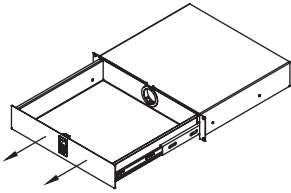

Locking Drawer (2RU)
 interior dims:
 $15\frac{3}{4}"$ W x $13\frac{1}{16}"$ D x $2\frac{1}{8}"$ H
 (25 lbs max load)
 97514

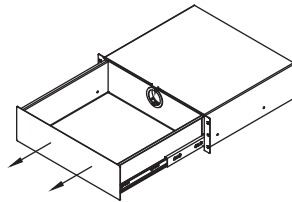

Drawer (3RU)
 interior dims:
 $15\frac{9}{16}"$ W x $14\frac{1}{2}"$ D x $5\frac{1}{4}"$ H
 (50 lbs max load)
 97518

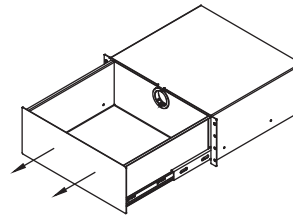

Drawer (4RU)
 interior dims:
 $15\frac{15}{16}"$ W x $14\frac{1}{2}"$ D x $7"$ H
 (50 lbs max load)
 97519

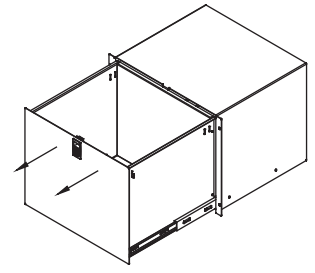

Locking File Drawer (8RU)
 w/ file holder
 interior dims:
 $15\frac{3}{4}"$ W x $13\frac{15}{16}"$ D x $13\frac{5}{16}"$ H
 (50 lbs max load)
 97515

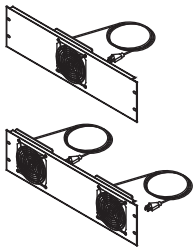

Cooling Fans (3RU)
 $19"$ W x $2"$ D x $5\frac{1}{4}"$ H
 Single Fan-97507
 Double Fan-97506

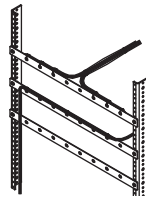

Wire Lace Kit
 3 lace straps included
 95517

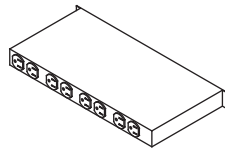

9-Outlet Power Strip (1RU)
 $19"$ W x $9"$ D x $1\frac{1}{4}"$ H
 99021

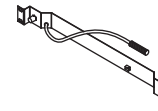

Flexible Halogen Light (1RU)
 $19"$ W x $2"$ D x $1\frac{3}{4}"$ H
 99033

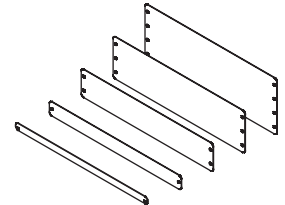

Rack-Mount Blanks
 (fills rack spaces where components are not needed)

97516 - ($\frac{1}{2}$ RU)
 97510 - (1RU)
 97511 - (2RU)
 97512 - (3RU)
 97513 - (4RU)

Warranty Statement

WE WILL MAKE IT RIGHT FOR YOU!

Spectrum is committed to provide complete customer satisfaction. Each of our products is manufactured from the best materials available and each product is stringently monitored throughout the production process through our P.A.C.E. program (Product Assurance to meet Customer Expectations).

We expressly warrant that Spectrum products will be of good quality and workmanship and free from defect for the period set out in the warranty table below from the date of delivery. This warranty shall not apply to defects or damage resulting from misuse, abuse, neglect, improper care, modification or repair not authorized by Spectrum, or any other cause outside the control of Spectrum. Spectrum will, at its sole option, either repair or replace the defective product.

This warranty is exclusive; no other warranty, written or oral, is expressed or implied. This warranty is given by Spectrum to Buyer and to no other person or legal entity. No Spectrum dealer, distributor, agent or employee is authorized to make any modification or addition to this warranty.

NOTWITHSTANDING ANYTHING TO THE CONTRARY, SPECTRUM WILL NOT UNDER ANY CIRCUMSTANCES BE LIABLE FOR INDIRECT OR LIQUIDATED DAMAGES, INCLUDING CONSEQUENTIAL, INCIDENTAL AND SPECIAL DAMAGES. IN NO EVENT SHALL SPECTRUM'S LIABILITY, WHETHER UNDER CONTRACT OR WARRANTY, IN TORT OR OTHERWISE, EXCEED THE PURCHASE PRICE RECEIVED BY SPECTRUM FOR THE PRODUCT AT ISSUE AND "RECALL ACTION" EXPENSES. SPECTRUM SHALL NOT BE SUBJECT TO ANY OTHER OBLIGATIONS OR LIABILITIES, WHETHER ARISING OUT OF BREACH OF CONTRACT, WARRANTY, TORT (INCLUDING NEGLIGENCE AND STRICT LIABILITY) OR OTHER THEORIES OF LAW, WITH RESPECT TO PRODUCTS SOLD OR SERVICES RENDERED BY SPECTRUM, OR ANY UNDERTAKINGS, ACTS OR OMISSIONS RELATING THERETO.

Our Customer Service Department is ready to provide immediate attention to any questions, comments or concerns. They are available to answer your calls Monday through Friday from 7 am to 5 pm CST. In addition your product comments or concerns are welcome via e-mail at: spectrum@spectrumfurniture.com.

Warranty Table

Item	Warranty Period
<ul style="list-style-type: none"> • Adjustable Crank/Electric Desk Legs • Flat Panel Desk Gas Cylinders 	<ul style="list-style-type: none"> • 1 Year
<ul style="list-style-type: none"> • Adjustable Height Chair Parts – including frames, gas cylinders, wood and plastic parts, and control handles Adjustable Height Chair Parts Casters • Adjustable Height Chair Upholstery • In-Stock Upholstery • Graded-In Fabrics and Customer Owned Material 	<ul style="list-style-type: none"> • 7 Years • 2 Years • 2 Years • No Warranty
<ul style="list-style-type: none"> • Height Adjustable Columns and Lifts • General Use Casters • Electrical • Keyboard/Mouse Trays 	<ul style="list-style-type: none"> • 1 Year
<ul style="list-style-type: none"> • Flat Panel Monitor Arm – General Parts • Flat Panel Monitor Arm – Gas Cylinders 	<ul style="list-style-type: none"> • 5 Years • 2 Years
<ul style="list-style-type: none"> • Computer Desk Chassis • Cart Chassis • Lectern Chassis 	<ul style="list-style-type: none"> • 10 Years



205 Westwood Ave, Long Branch, NJ 07740
 Phone: 866-94 BOARDS (26273) / (732)-222-1511
 Fax: (732)-222-7088 | E-mail: sales@touchboards.com



INDOOR AIR QUALITY
 Indoor Advantage | Furniture



925 First Avenue, PO Box 400, Chippewa Falls, WI 54729 Ph: 800-235-1262, 715-723-6750 Fax: 800-335-0473, 715-738-2309

E-mail: spectrum@spectrumfurniture.com web: www.spectrumfurniture.com