

## Technical Specifications

# Touchboards

205 Westwood Ave, Long Branch, NJ 07740  
Phone: 866-94 BOARDS (26273) / (732)-222-1511  
Fax: (732)-222-7088 | E-mail: sales@touchboards.com

55211	Standard CPL
55224	with Overbridge Control Console™ (also requires 96501 insert panel)

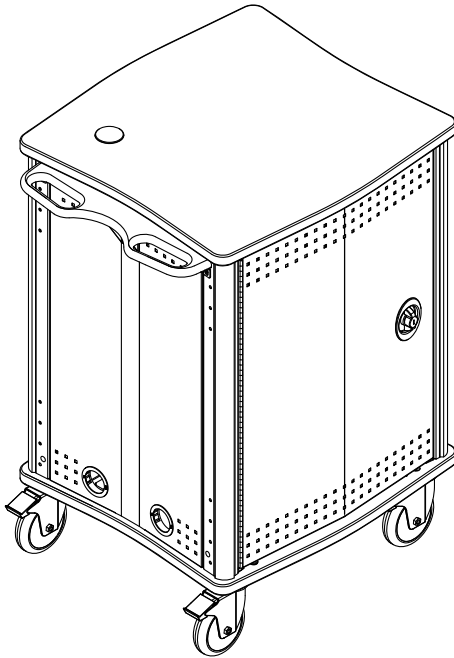

Standard CPL  
with Balloon Wheels  
55211BW

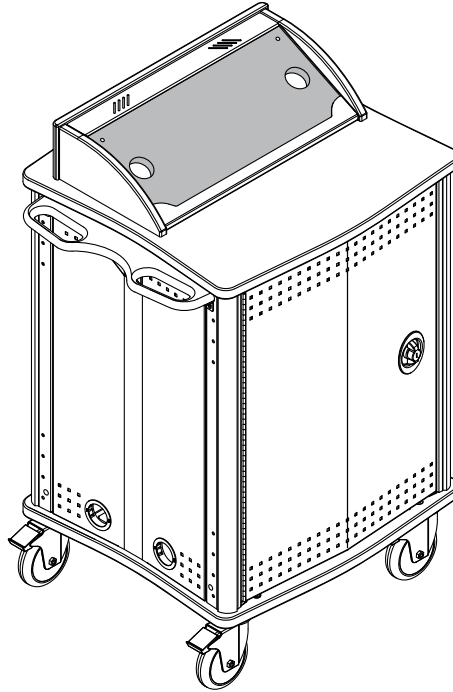

CPL with Overbridge Control Console  
and Balloon Wheels  
55224BW  
shown with optional  
insert panel (shaded)

Base
BW - 4 Swivel Balloon Wheels
TK - Toe Kick

Options
Page 9

Use the Compact Presentation Lectern when you need mobility offered in a small footprint and the flexibility that comes with rack rail compatible equipment. The CPL's small size (26.5"W x 24.9375"D x 38.8125"H) and 5"soft-rubber balloon wheels on swivel plates ensure easy mobility and a quiet ride over thresholds and rough flooring. The CPL can accommodate rack mounted technology and rack-mounted accessories with front rack rail of 16 rack units, or up to 32 rack units with optional rear rack rail. Fingertip control is possible with optional Overbridge Control Console ready to mount your choice of technology.

## Features and Benefits

- Durable powder coated steel chassis
- Overbridge console version allows custom cutouts and installation of presentation controllers and control panels
- Scratch and impact-resistant 1.063" high-pressure laminate worksurface
- Four 5" locking balloon wheels roll easily and quietly on uneven surfaces
- Toe Kick (TK) version available when mobility is not necessary or desired
- 2" cable grommet(s) on the worksurface or overbridge provide cable access
- One standard recycled plastic handle provides control and mobility
- Rack-rail simplifies equipment installation, while providing enough storage space for an internal CPU
- Double-bolt, keyed locking front and rear doors provide security and easy-access
- Ventilated side panels and doors help keep equipment cool
- Cable grommets keep wires and cords organized
- Optional adjustable-height, flip-up shelf provides a convenient additional worksurface
- Warranted to be free of all defects in materials and workmanship with a 10-year warranty

## Color Options

Standard laminate / color combinations

Wild Cherry / Black  
(CHB)



Indigo Organix / Black  
(IB)



Indigo Organix / Dark Gray  
(ID)



Bannister Oak / Black  
(KB)



Bannister Oak / Putty  
(KP)



Fusion Maple / Black  
(FMB)



Standard color combination refers to the quickest deliverable product color combination. Custom laminates and color combinations are available—additional lead-times and up-charges may apply. Call 1-800-235-1262 for further information.

# Construction

- The worksurface and base panel is constructed from 1.063" thick NAUF (no added urea formaldehyde) composite board with .030" high-pressure laminate on one face, and a balancing phenolic backer on the opposing face
- 16-gauge steel doors and corner columns
- Worksurface edges are covered with 3mm vinyl
- All metal components are finished with a scratch-resistant powder coat epoxy
- Each CPL factory-assembled with casters or toe kick, packaged, and shipped on its own skid (handle to be installed by customer)

# Specifications

Total internal area	21.5"W x 20.5"D x 30.5"H
Standard rack rail	16RU
5" balloon wheels	weight capacity 325 lbs each
Available cutout area in blank overbridge panel	14.25"W x 8"D
Unit weight (nominal)	117 lbs 122 lbs - with overbridge
Shipping weight (nominal)	154 lbs 159 lbs - with overbridge
Meets or exceeds applicable ANSI-BIFMA test standards	

*Specifications subject to change without notice*

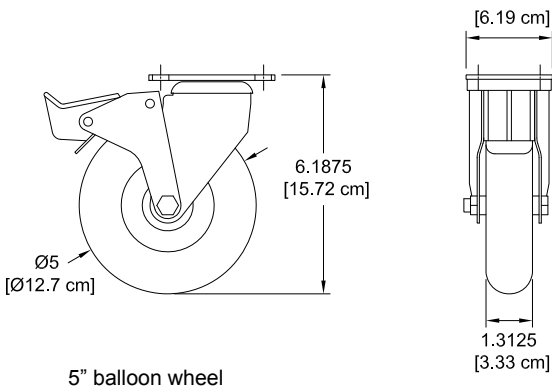

Note: The CPL comes with rack rails mounted in the front (instructor side) position. They can be moved to the rear position (student side) if required. Optional rear rack rails are also available.

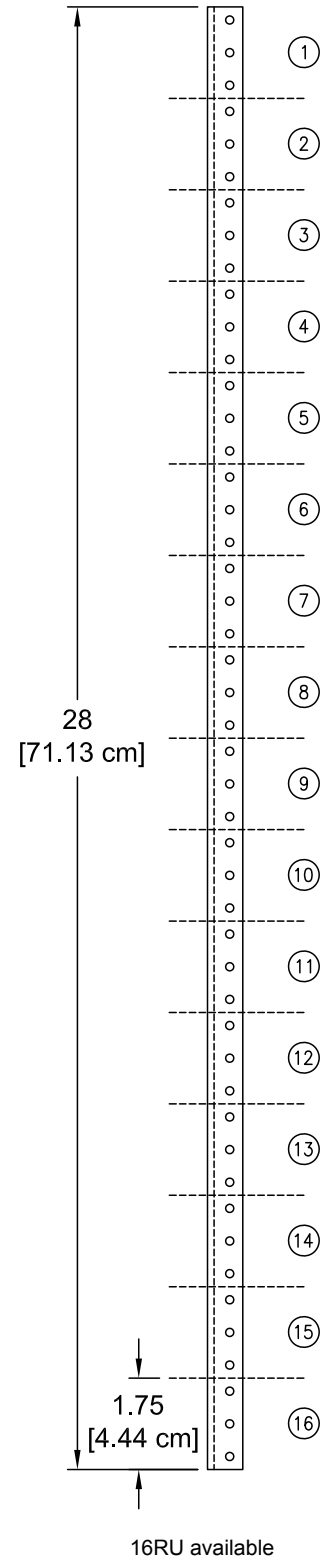

# Models

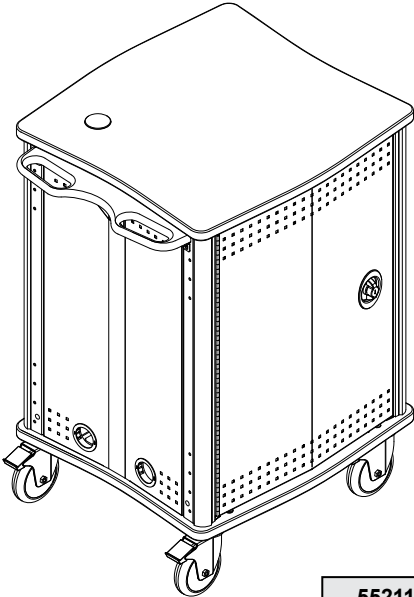
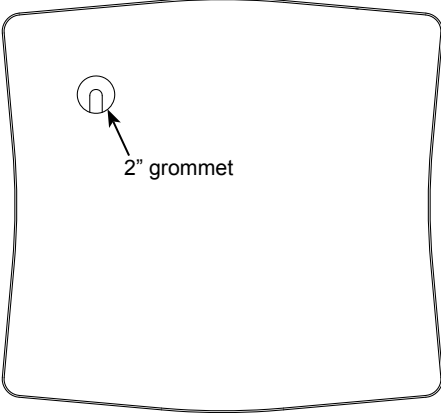
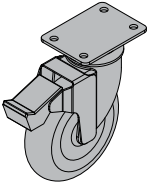
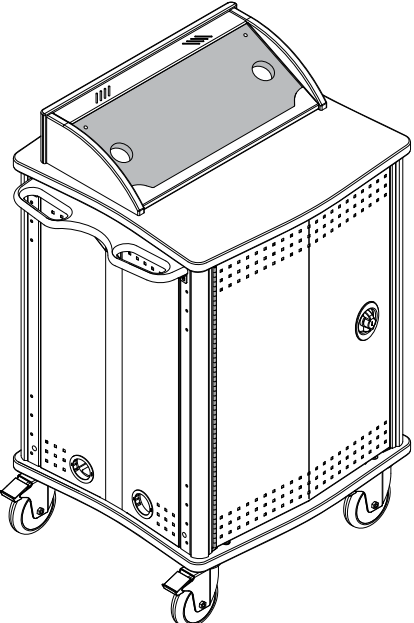
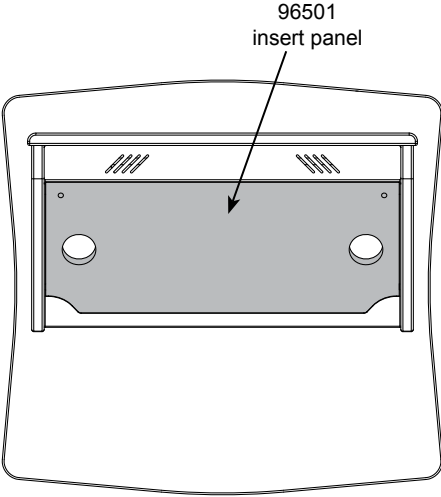
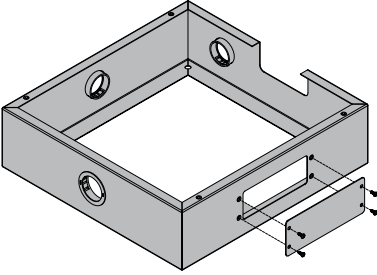
	Worksurface:	Base Options:
<p><b>Standard CPL</b></p>  <p style="text-align: right;"><b>55211</b></p>	 <p>2" grommet</p> <p>Blank worksurface with one 2" grommet in worksurface.</p>	 <p>X 4</p> <p><b>BW</b> 5" Swivel Balloon Wheels</p>
<p><b>CPL with Overbridge Control Console</b></p>  <div data-bbox="131 1717 553 1833" style="border: 1px solid black; padding: 5px;"> <p>Note: The insert panel shown (<i>shaded</i>) is <u>not</u> included with the lectern or overbridge. This option needs to be ordered separately to complete the overbridge.</p> </div> <p style="text-align: right;"><b>55224</b></p>	 <p>96501 insert panel</p> <p>Overbridge with blank insert panel for custom cutouts (see p.7 for dimensions). Overbridge is not available separately. Includes two 2" grommet holes with covers.</p>	 <p>X 4</p> <p><b>TK</b> Toe Kick</p>

Compact Presentation Lectern  
with Balloon Wheels

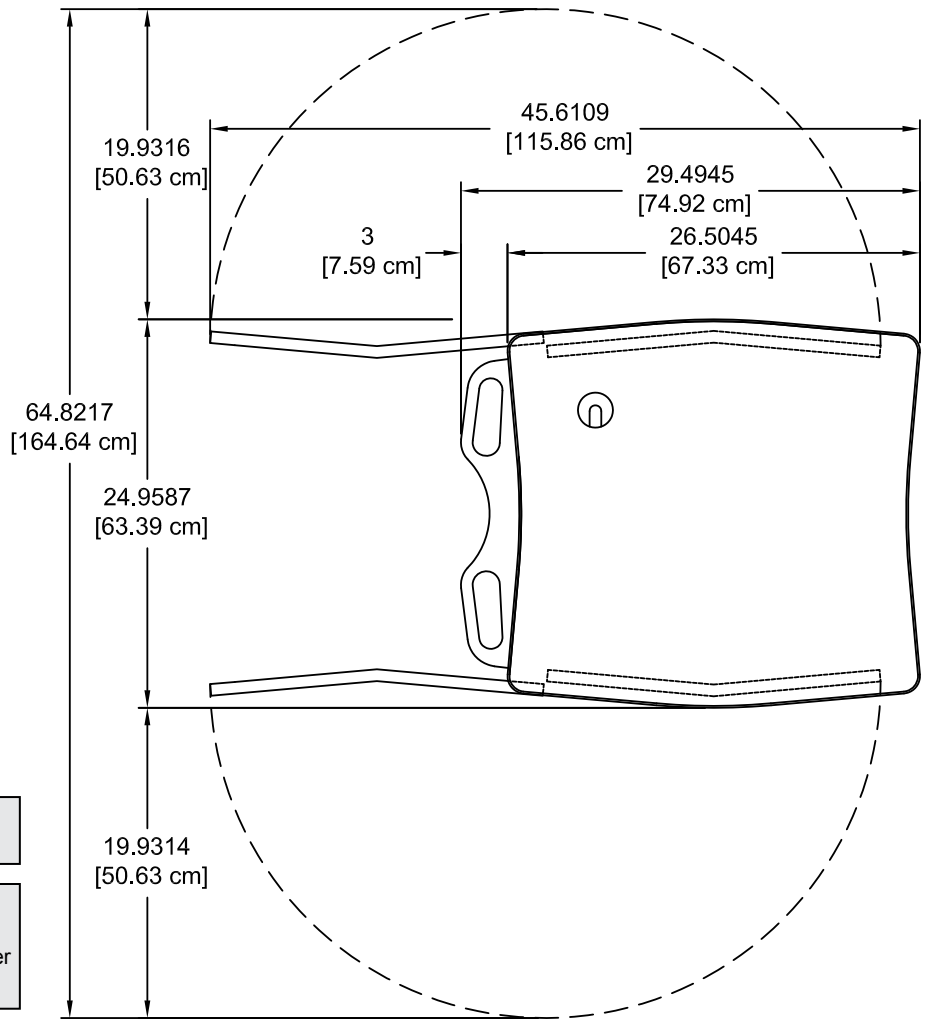
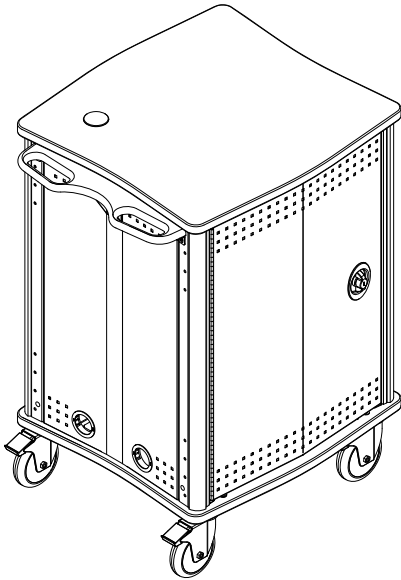

Note: The handle and optional shelf are interchangeable and can be mounted on either side.

Note: Modified worksurface cutouts should be reviewed by Spectrum to ensure clearance of brackets, keyboard slides, or other objects under the worksurface.

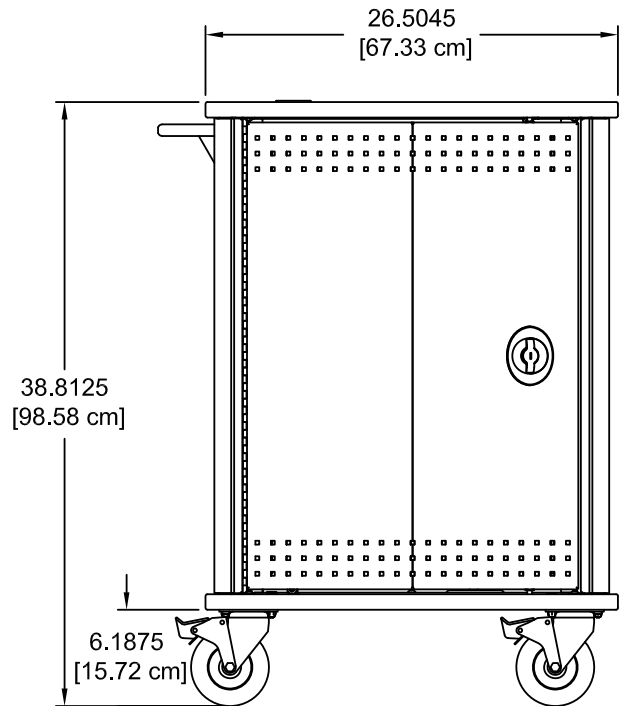
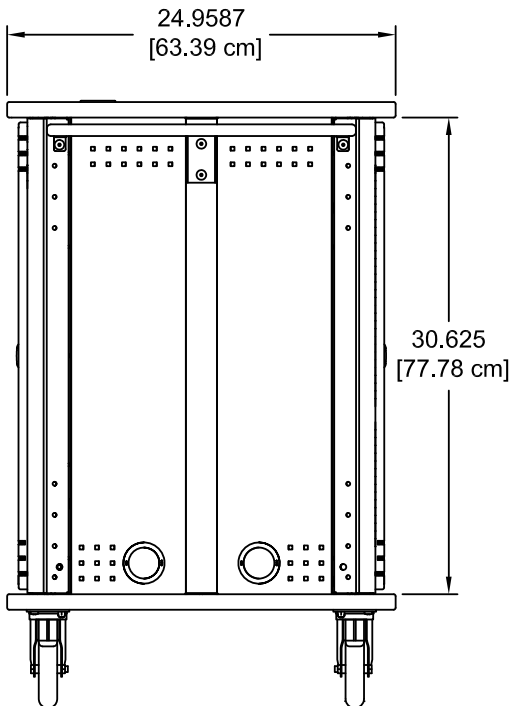

CPL section view

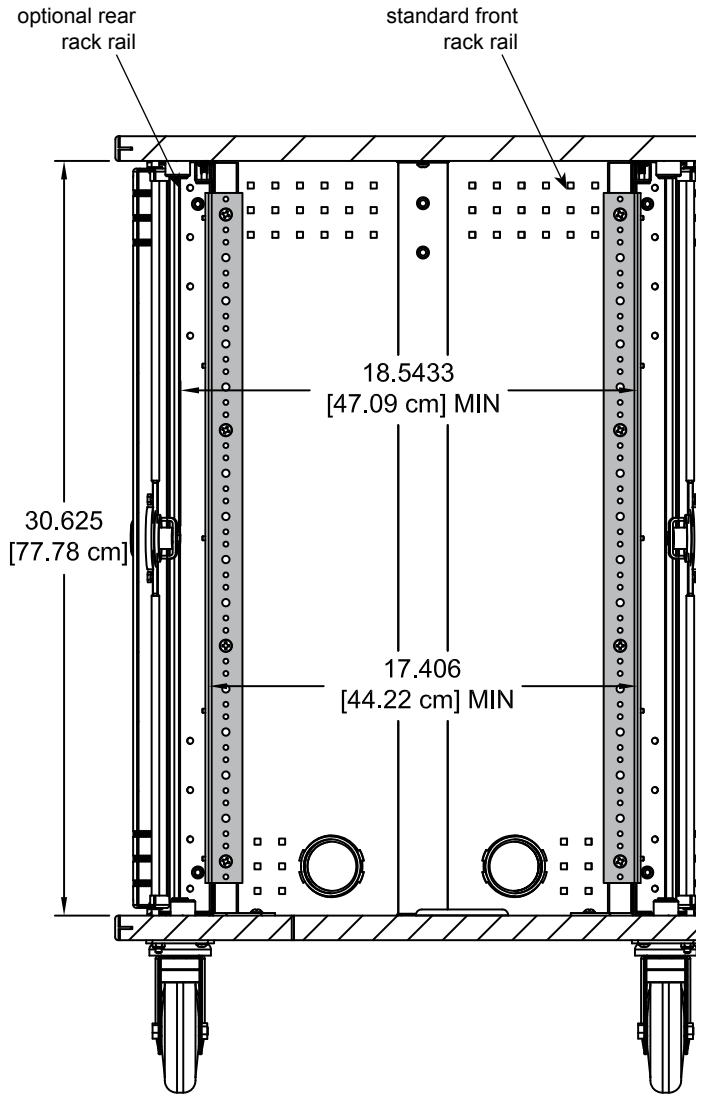
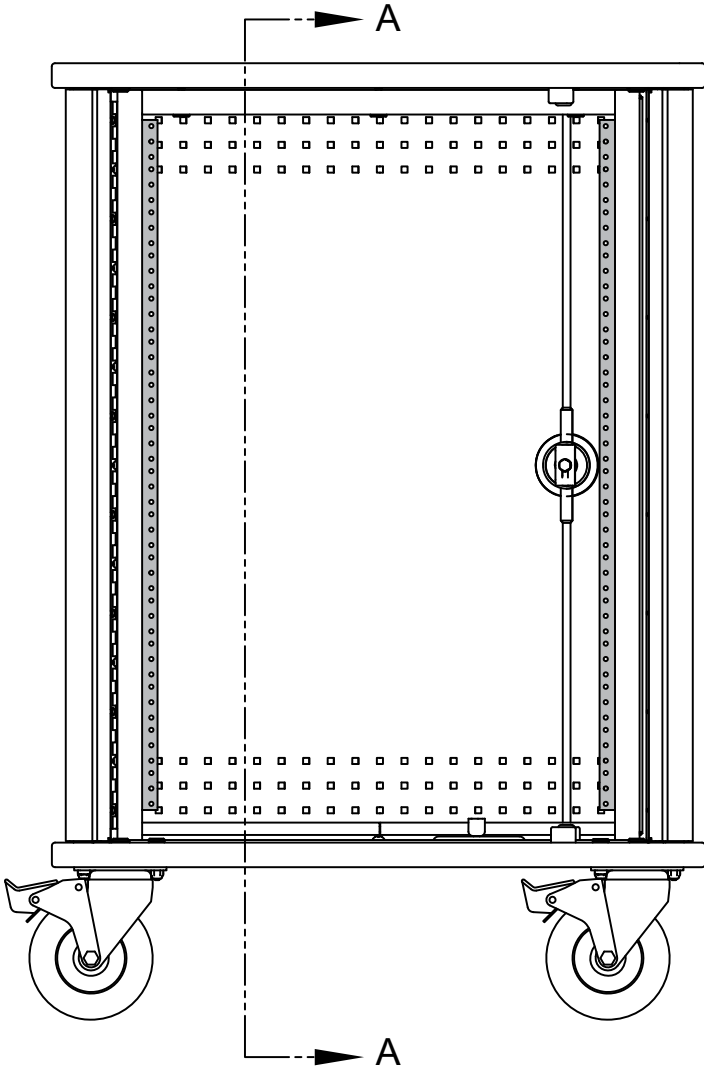

Toe Kick front view

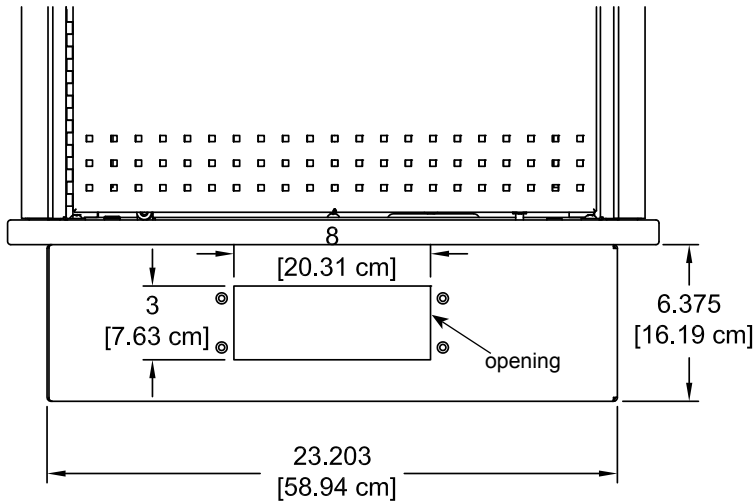

Toe Kick side view

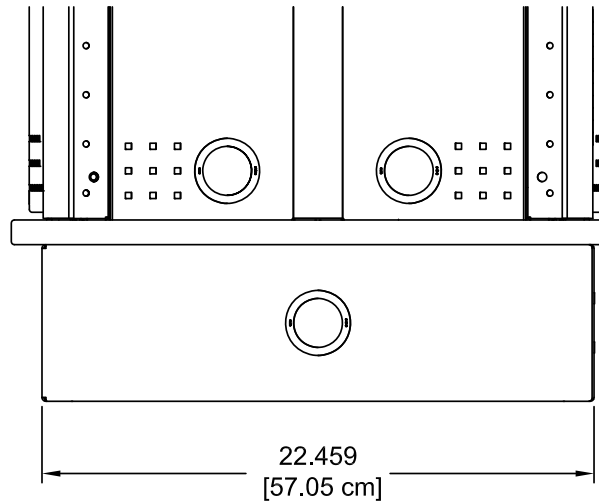

Compact Presentation Lectern  
with Overbridge Control Console™ and balloon wheels

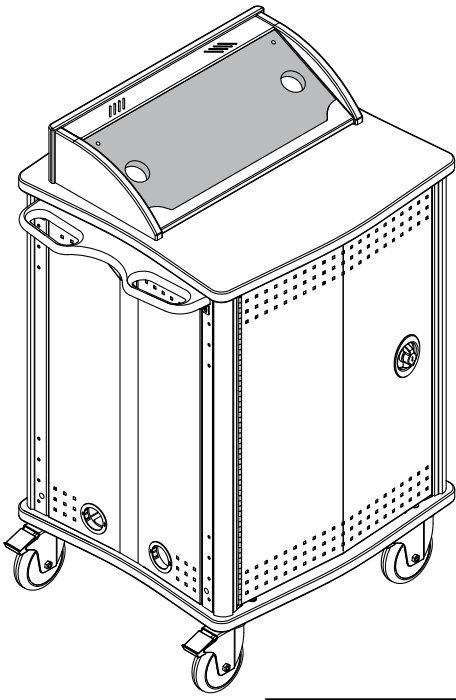

Note: The insert panel shown (*shaded*) is not included with the lectern or overbridge. This option needs to be ordered separately to complete the overbridge.

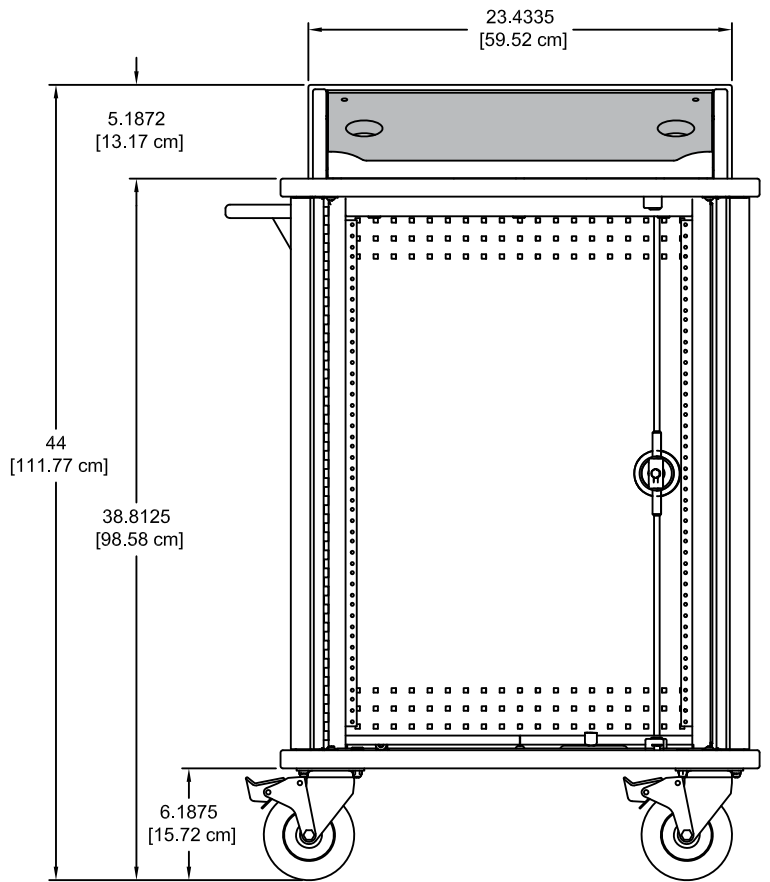
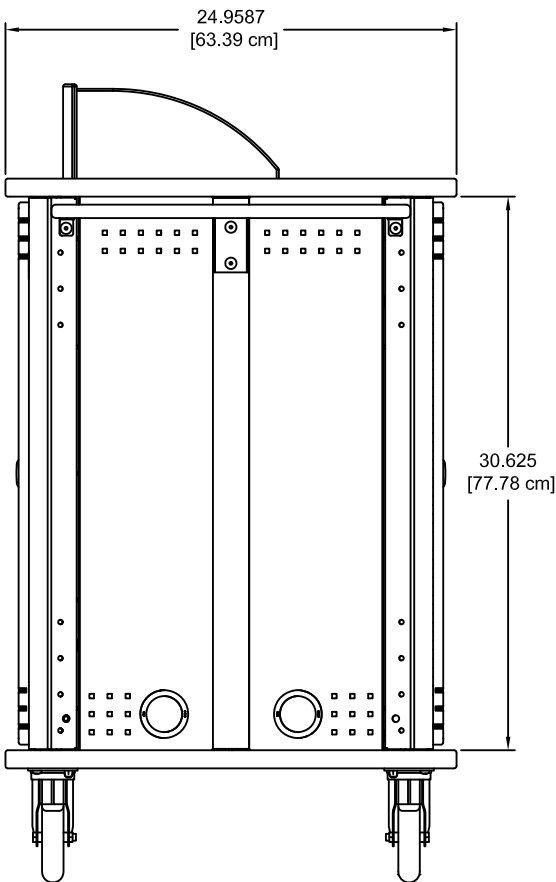
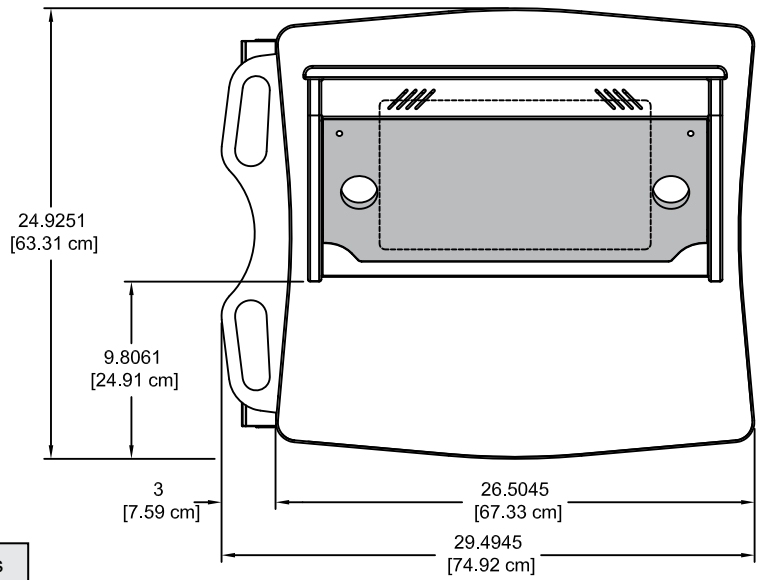

(shown with door removed)

CPL overbridge panel blank  
(flat view)

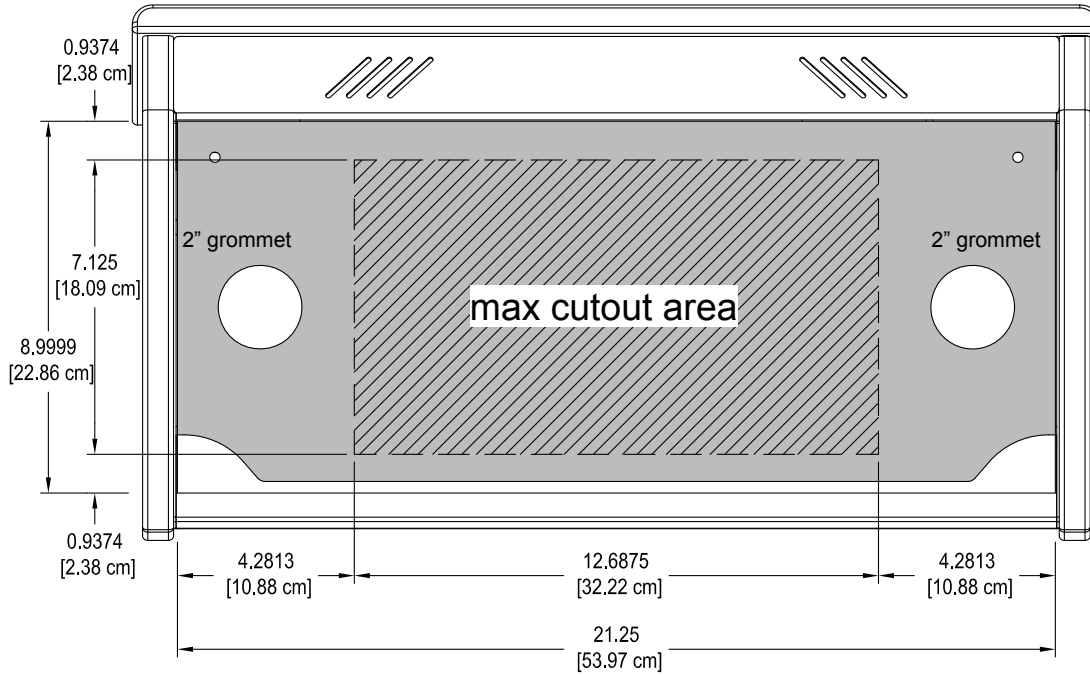

Note: The Overbridge Control Console™ has been designed for many of the currently available controllers on the market, however, modified cutouts should be reviewed by Spectrum to ensure clearance of brackets, keyboard slides, or other objects under the worksurface.

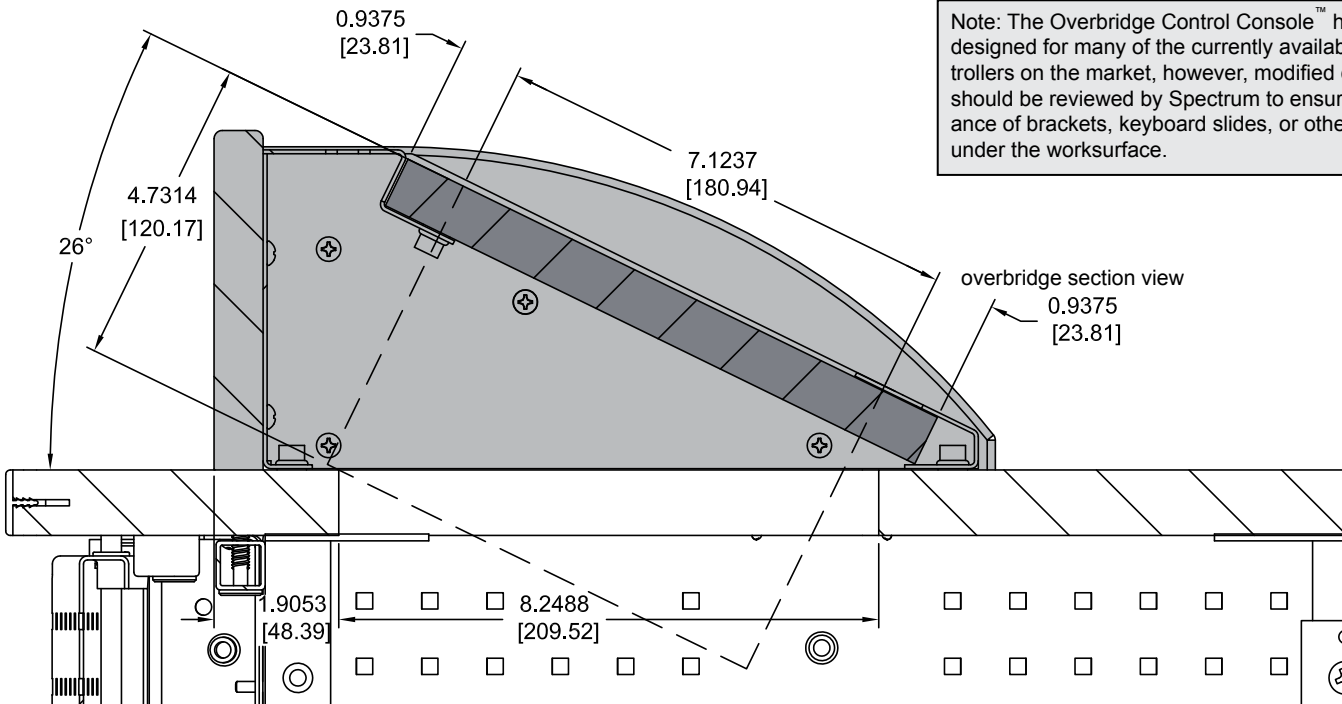

Note: The insert panel shown (shaded) is not included with the lectern or overbridge. This option needs to be ordered separately to complete the overbridge. This insert panel is horizontally symmetrical and can be easily removed, rotated, and re-installed if a cutout needs to be relocated to the opposite side of the overbridge.

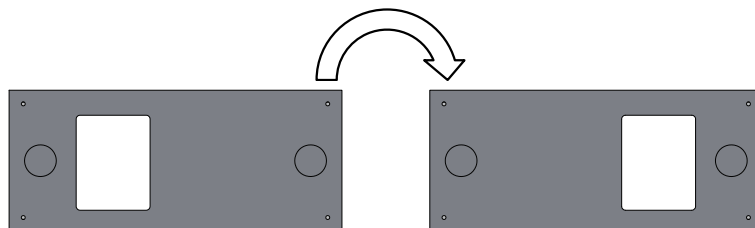

available positions on base panel for optional cord reel

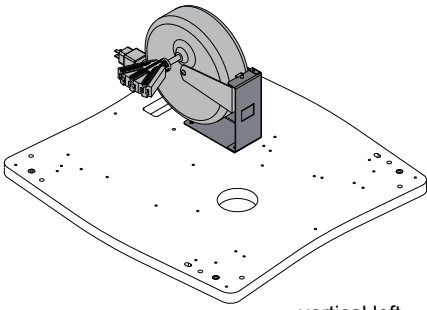

vertical left  
(takes up 6RU)

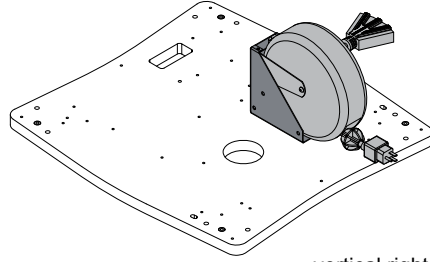

vertical right  
(takes up 6RU)

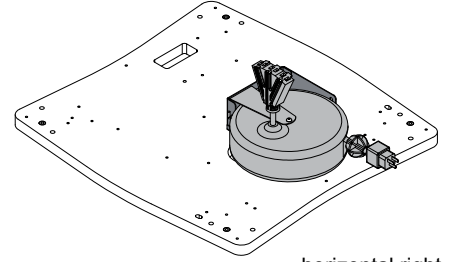

horizontal right  
(takes up 3RU)

CPL with optional universal cord reel kit 99037  
(available rack spacing)

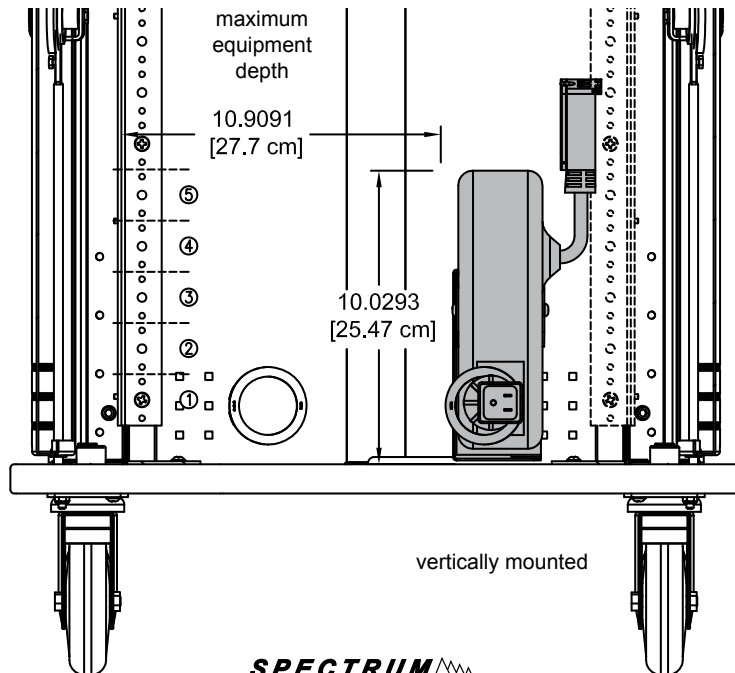
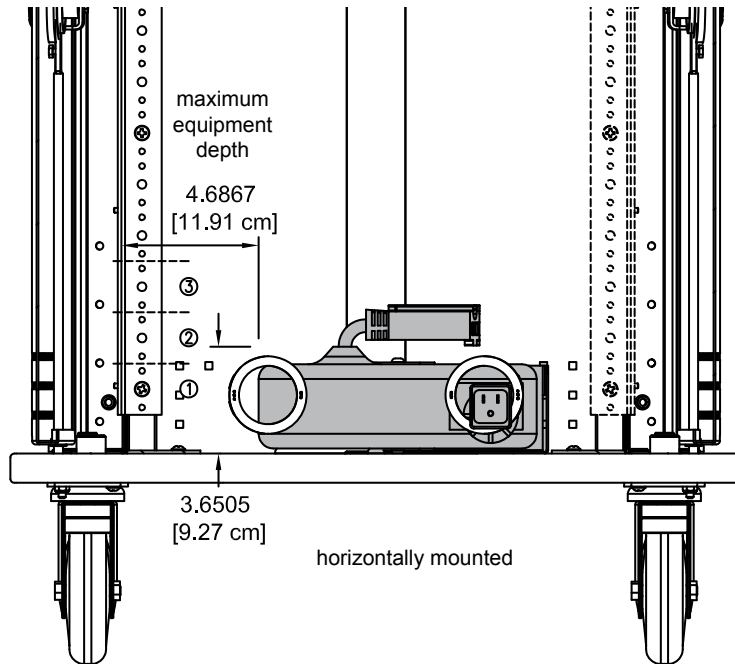



# Options

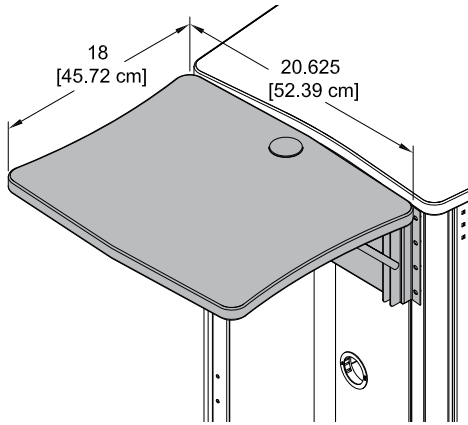

**Flip-up Shelf**  
 adjustable-height, mounts on left or right  
 18"W x 20.625"D  
 (50 lbs max load)  
 55219

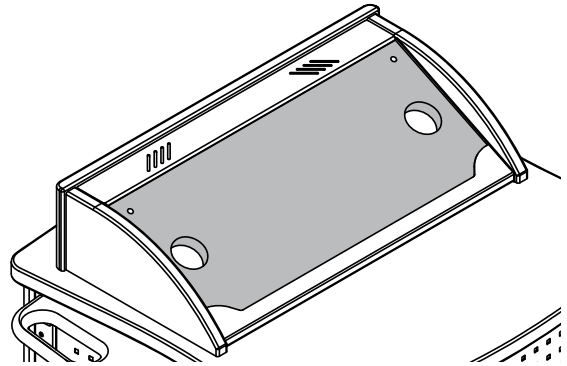

**Overbridge Insert Panel**  
 for overbridge version only-contact Spectrum to specify cutout size(s) and position(s)-overbridge not available separately  
 (includes two 2" grommets with covers)  
 96501 - blank panel  
 96501mod - panel with cutout(s)

Note: Power and communication wiring for document cameras, laptop computers, and/or projectors placed on the flip-up shelf should be routed on top of the audience-side of the shelf. Use of the shelf grommet hole for wiring will result in pinching of the cords when the shelf is folded.

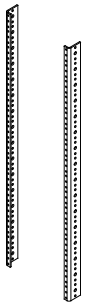

**Rear rack rail kit for CPL**  
 adds 16RU (17.375" between front and rear rails when installed)  
 55221

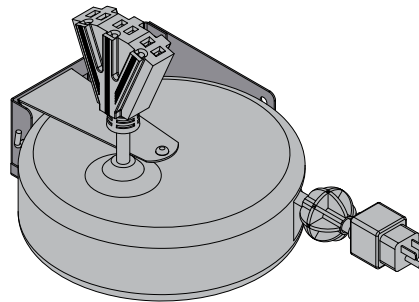

**Universal Cord Reel Kit**  
 15' [457.2 cm] retractable, 12 AWG, with breaker, includes universal mounting bracket (mounts horizontally or vertically inside lectern to base panel) 10 lbs [.45 kg]  
 99037



Note: When installed, the cord reel takes up rack units from the bottom of the rack rail.  
 Horizontal installation: 3RU  
 Vertical installation: 6RU



The cord reel is intended to provide temporary access to electrical outlets for Spectrum mobile lecterns. Check local electrical codes prior to installation.

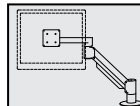

**Flat Panel Monitor Arms and Tablet Mounts**  
 (See the Spectrum website or catalog for the latest available monitor arm and tablet mounting options)

Note: Drilling is required to mount to the worksurface

# Rack-mount accessories

Note: Rack-mount accessories with a depth greater than 18.5625"D will not fit in the CPL. Check the dimensions of all equipment before installation. The following Spectrum rack-mount accessories will not fit the CPL:

97517 - LT-4 Laptop Storage Unit  
 97503 - Pull-out Shelf (3RU)

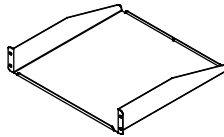

**Cantilever Shelf (2RU)**  
 17.5"W x 18"D x 3.5"H  
 (50 lbs max load)  
 97504

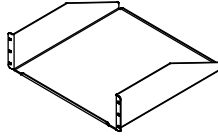

**Cantilever Shelf (3RU)**  
 17.5"W x 18"D x 5.25"H  
 (80 lbs max load)  
 97502

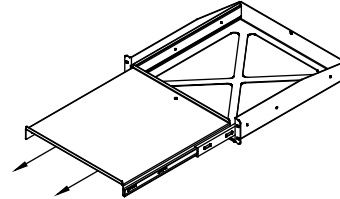

**Pull-Out Shelf (2RU)**  
 16.5"W x 17.75"D  
 (50 lbs max load)  
 97505

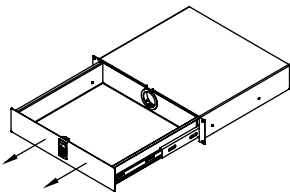

**Locking Drawer (2RU)**  
 interior dims:  
 15.75"W x 13.6875"D x 2.875"H  
 (25 lbs max load)  
 97514

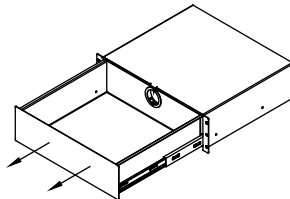

**Drawer (3RU)**  
 interior dims:  
 15.9375"W x 14.5"D x 5.25"H  
 (50 lbs max load)  
 97518

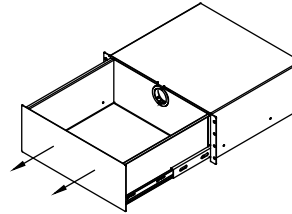

**Drawer (4RU)**  
 interior dims:  
 15.9375"W x 14.5"D x 7"H  
 (50 lbs max load)  
 97519

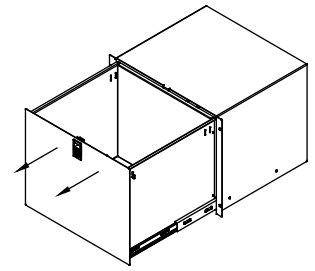

**Locking File Drawer (8RU)**  
 with file holder  
 interior dims:  
 15.75"W x 13.5625"D x  
 13.3125"H  
 (50 lbs max load)  
 97515

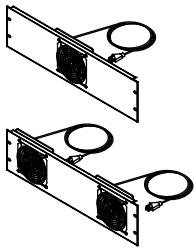

**Cooling Fans (3RU)**  
 19"W x 2"D x 5.25"H  
 Single Fan-97507  
 Double Fan-97506

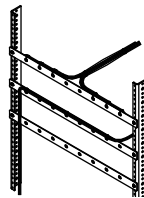

**Wire Lace Kit**  
 3 lace straps included  
 95517

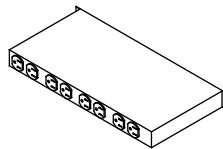

**9-Outlet Power Strip (1RU)**  
 19"W x 9"D x 1.75"H  
 99021

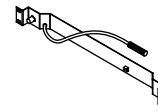

**Flexible Halogen Light (1RU)**  
 19"W x 2"D x 1.75"H  
 99033

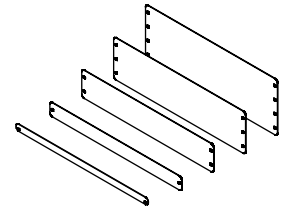

**Rack-Mount Blanks**  
 (fills rack spaces where components are not needed)

97516 - (1/2 RU)  
 97510 - (1RU)  
 97511 - (2RU)  
 97512 - (3RU)  
 97513 - (4RU)

# Warranty

## WE WILL MAKE IT RIGHT FOR YOU!

Spectrum is committed to provide complete customer satisfaction. Each of our products is manufactured from the best materials available and each product is stringently monitored throughout the production process through our P.A.C.E. program (Product Assurance to meet Customer Expectations).

We expressly warrant that Spectrum products will be of good quality and workmanship and free from defect for the period set out in the warranty table below from the date of delivery. This warranty shall not apply to defects or damage resulting from misuse, abuse, neglect, improper care, modification or repair not authorized by Spectrum, or any other cause outside the control of Spectrum. Spectrum will, at its sole option, either repair or replace the defective product.

This warranty is exclusive; no other warranty, written or oral, is expressed or implied. This warranty is given by Spectrum to Buyer and to no other person or legal entity. No Spectrum dealer, distributor, agent or employee is authorized to make any modification or addition to this warranty.

**NOTWITHSTANDING ANYTHING TO THE CONTRARY, SPECTRUM WILL NOT UNDER ANY CIRCUMSTANCES BE LIABLE FOR INDIRECT OR LIQUIDATED DAMAGES, INCLUDING CONSEQUENTIAL, INCIDENTAL AND SPECIAL DAMAGES. IN NO EVENT SHALL SPECTRUM'S LIABILITY, WHETHER UNDER CONTRACT OR WARRANTY, IN TORT OR OTHERWISE, EXCEED THE PURCHASE PRICE RECEIVED BY SPECTRUM FOR THE PRODUCT AT ISSUE AND "RECALL ACTION" EXPENSES. SPECTRUM SHALL NOT BE SUBJECT TO ANY OTHER OBLIGATIONS OR LIABILITIES, WHETHER ARISING OUT OF BREACH OF CONTRACT, WARRANTY, TORT (INCLUDING NEGLIGENCE AND STRICT LIABILITY) OR OTHER THEORIES OF LAW, WITH RESPECT TO PRODUCTS SOLD OR SERVICES RENDERED BY SPECTRUM, OR ANY UNDERTAKINGS, ACTS OR OMISSIONS RELATING THERETO.**

Our Customer Service Department is ready to provide immediate attention to any questions, comments or concerns. They are available to answer your calls Monday through Friday from 7 am to 5 pm CST. In addition your product comments or concerns are welcome via e-mail at: [spectrum@spectrumfurniture.com](mailto:spectrum@spectrumfurniture.com).

Warranty Table

Item	Warranty Period
<ul style="list-style-type: none"> <li>Adjustable Crank/Electric Desk Legs</li> <li>Flat Panel Desk Gas Cylinders</li> </ul>	<ul style="list-style-type: none"> <li>1 Year</li> </ul>
<ul style="list-style-type: none"> <li>Adjustable Height Chair Parts – including frames, gas cylinders, wood and plastic parts, and control handles Adjustable Height Chair Parts Casters</li> <li>Adjustable Height Chair Upholstery</li> <li>In-Stock Upholstery</li> <li>Graded-In Fabrics and Customer Owned Material</li> </ul>	<ul style="list-style-type: none"> <li>7 Years</li> <li>2 Years</li> <li>2 Years</li> <li>No Warranty</li> </ul>
<ul style="list-style-type: none"> <li>Height Adjustable Columns and Lifts</li> <li>General Use Casters</li> <li>Electrical</li> <li>Keyboard/Mouse Trays</li> </ul>	<ul style="list-style-type: none"> <li>1 Year</li> </ul>
<ul style="list-style-type: none"> <li>Flat Panel Monitor Arm – General Parts</li> <li>Flat Panel Monitor Arm – Gas Cylinders</li> </ul>	<ul style="list-style-type: none"> <li>5 Years</li> <li>2 Years</li> </ul>
<ul style="list-style-type: none"> <li>Computer Desk Chassis</li> <li>Cart Chassis</li> <li>Lectern Chassis</li> </ul>	<ul style="list-style-type: none"> <li>10 Years</li> </ul>

