

Technical Specifications

55209

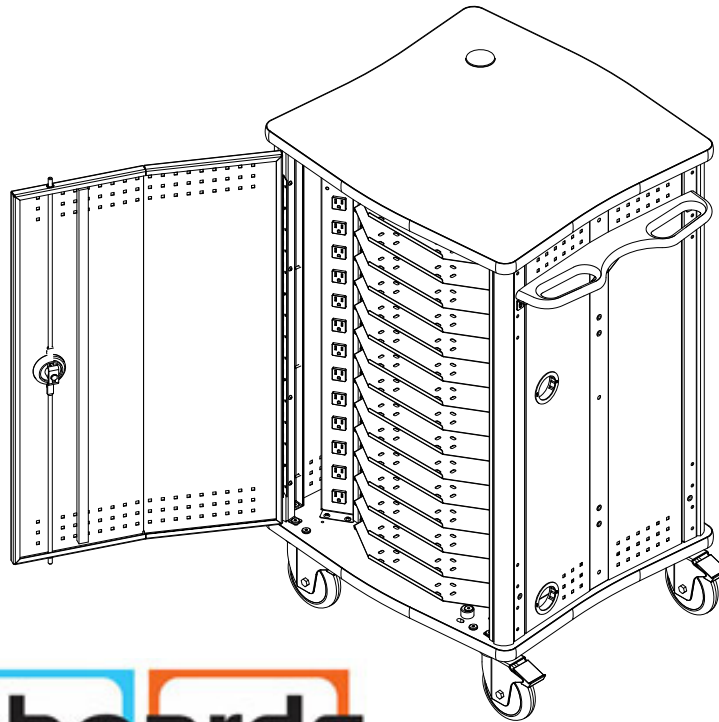

205 Westwood Ave, Long Branch, NJ 07740
 Phone: 866-94 BOARDS (26273) / (732)-222-1511
 Fax: (732)-222-7088 | E-mail: sales@touchboards.com

Use the LT-15 Laptop Cart to store and charge up to 15 laptops, tablets or other mobile computing devices. Padded horizontal pull-out shelves protect the laptops and provide easy access to the laptops. Power cords and wire management is located on each shelf for quick power management. Line voltage access is separated from the laptops access. Dual-bolt locks on the doors increase security of the laptops and keep students from the line voltage. The LT-15 Cart is made with powder coated steel for security and durable, long-lasting finish. The cart is mobile with 5-inch balloon wheels, which reduce vibration and roll easily over uneven floors.

Features and Benefits

- 15 laptop trays pull-out from front and back, providing quick and easy-access to laptops and cables
- Cable grommets and wire management located in each tray keep wires and cords organized (Velcro® tie-downs included)
- Scratch and impact resistant 1.063" high-pressure laminate worksurface and base panel
- Double-bolt, keyed locking doors provide security and easy-access
- Four 5" swivel locking balloon wheels roll easily and quietly on uneven surfaces
- 2" cable grommet on the worksurface provides cable access
- Ventilated door and side panels keep equipment cool
- Conveniently-located 15-outlet, 125V power unit with 15-amp breaker and reset button
- Electrical system consists of UL-listed components
- External cord management brackets keep power cord organized
- One standard ergonomic handle provides control and mobility
- Optional adjustable-height, flip-up shelf provides a convenient additional worksurface
- Optional tray edge trim applies to pull edge and provides additional grip to each tray
- Warranted to be free of all defects in materials and workmanship with a 10-year warranty. Electrical system 1 year.

Base
BW - 5" Balloon Wheels (4 swivel) SR - 5" Balloon Wheels (2 rigid, 2 swivel)

Options
Page 6

Color Options

Standard laminate / color combinations

Wild Cherry / Black (CHB) 

Indigo Organix / Dark Gray (ID) 

Standard color combination refers to the quickest deliverable product color combination. Custom laminates and color combinations are available-additional lead-times and up-charges may apply. Call 1-800-235-1262 for further information.

Construction

- The worksurface and base panels are constructed from 1.063" thick NAUF (No Added Urea Formaldehyde) composite board with .030" high-pressure laminate on one face, and a balancing phenolic backer on the opposing face
- 20-gauge steel pull-out laptop trays and side panels
- 16-gauge steel doors and corner columns
- Worksurface and base panel edges are covered with 3mm vinyl
- Ergonomic handle is made of black recycled plastic
- All metal components are finished with a scratch-resistant powder coat epoxy
- Solid wood corner trim
- Each LT-15 is factory-assembled with wheels, packaged, and shipped on its own skid (*handle to be installed by customer*)

Specifications

Capacity	15 laptops	
Storage bays (nominal)	16.5"W x 20.5"D x 2.281"H *maximum recommended load per tray not to exceed 7 lbs	
Electrical	<ul style="list-style-type: none"> • (1) 15 outlet 12-amp, 125 volt, 60Hz power unit • 15-amp breaker • on/off switch • 15' nominal 14 AWG, 3-wire power cord 	<ul style="list-style-type: none"> • outlets are accessible from the back of the unit via locking door • UL listed components
5" Balloon Wheels	weight capacity 325 lbs each	
Unit weight (nominal)	206 lbs	
Shipping weight (nominal)	240 lbs	
Meets or exceeds applicable ANSI-BIFMA test standards		

Specifications subject to change without notice

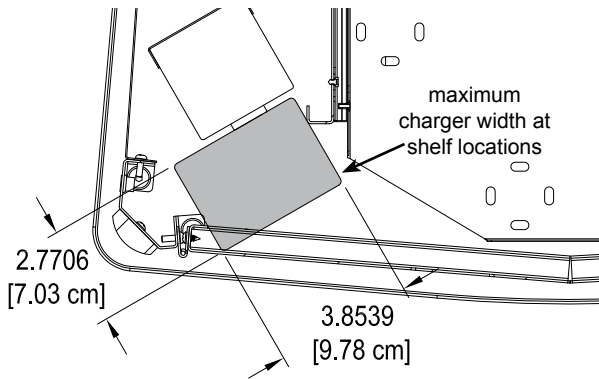

outlet spacing on 15 outlet power unit

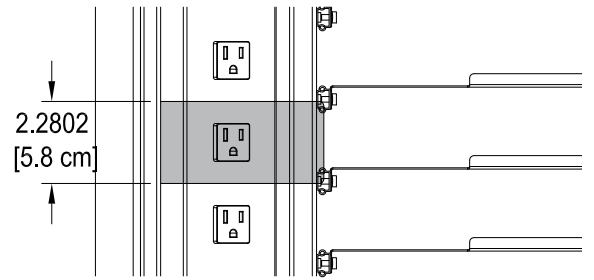

maximum charger height

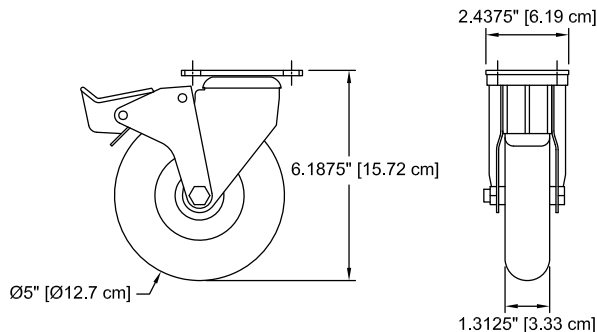

5" balloon wheel (BW)

LT-15 Laptop Cart

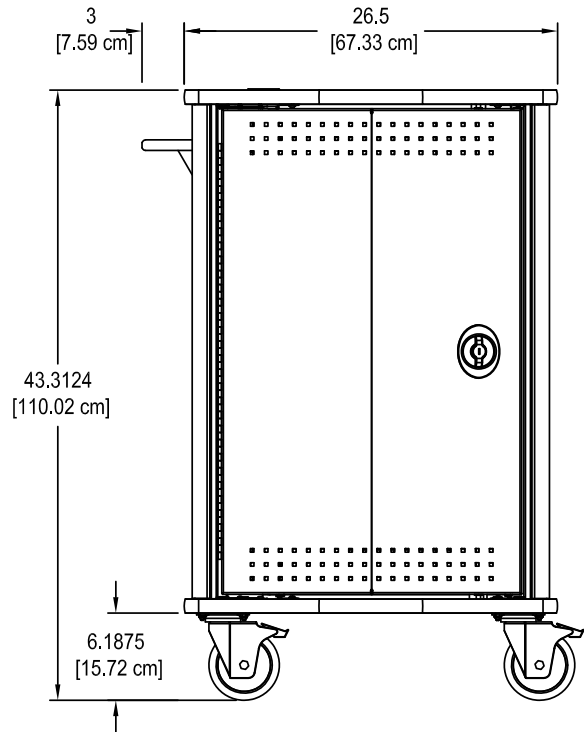
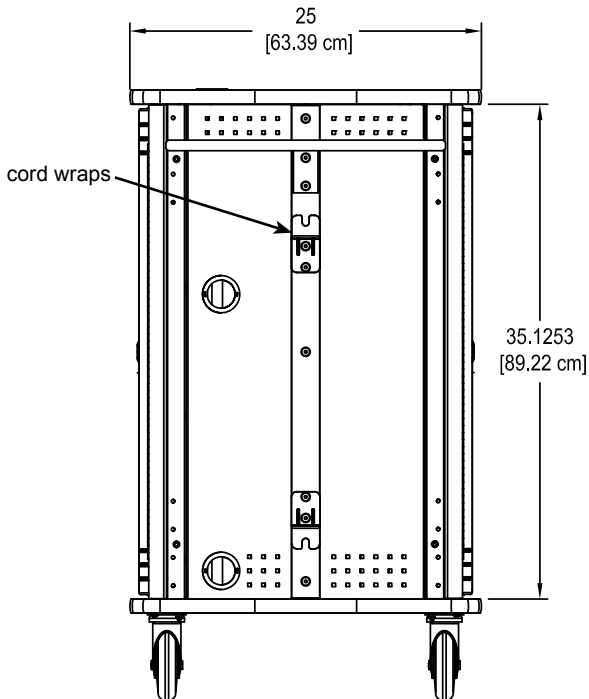
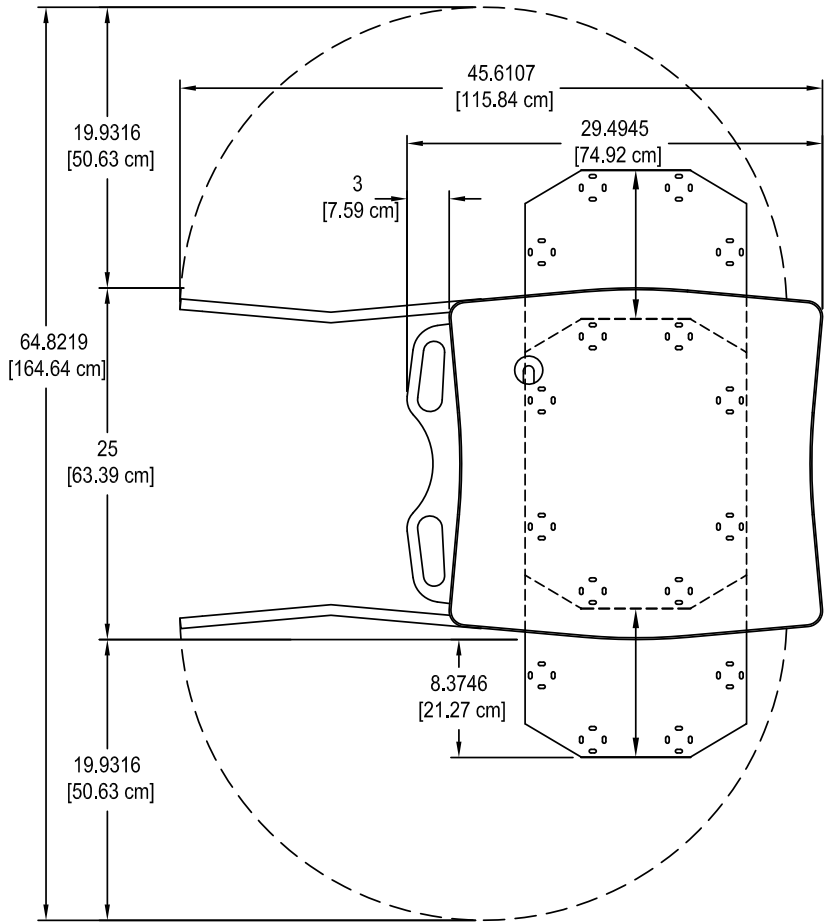
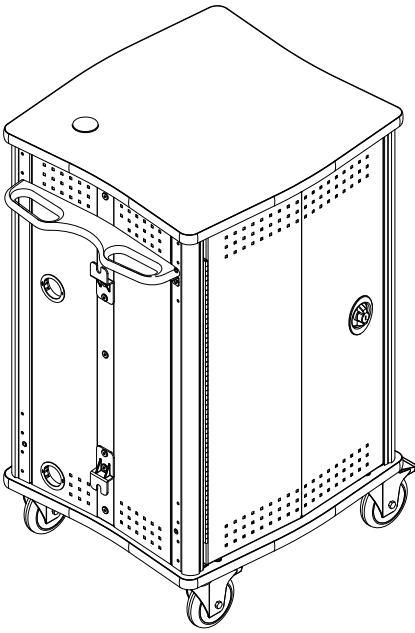

laptop tray

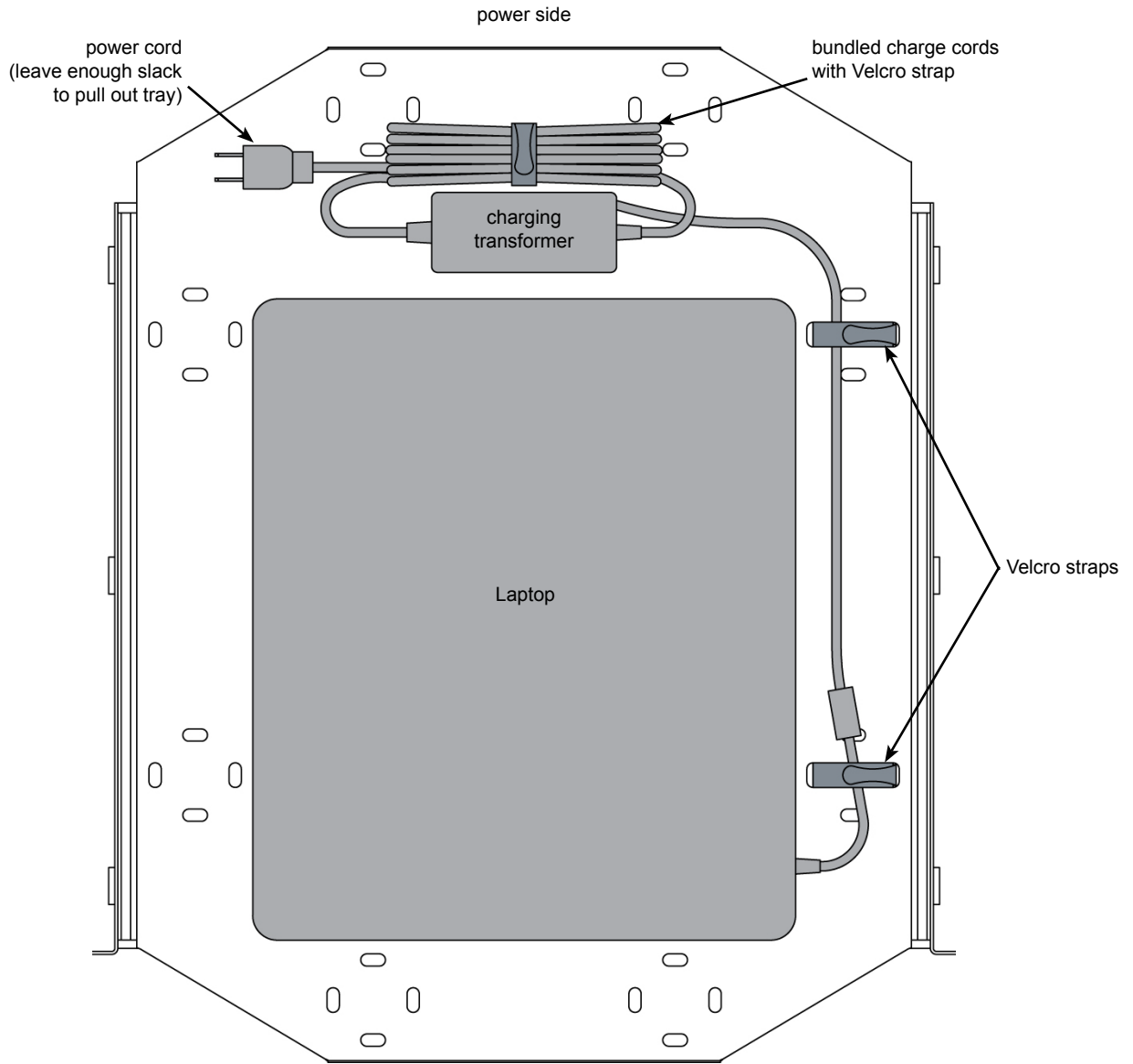

student side

Touchboards

205 Westwood Ave, Long Branch, NJ 07740
Phone: 866-94 BOARDS (26273) / (732)-222-1511
Fax: (732)-222-7088 | E-mail: sales@touchboards.com

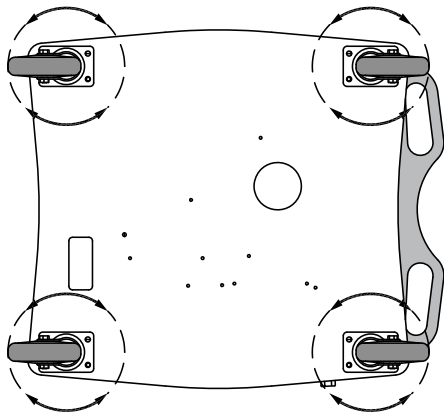
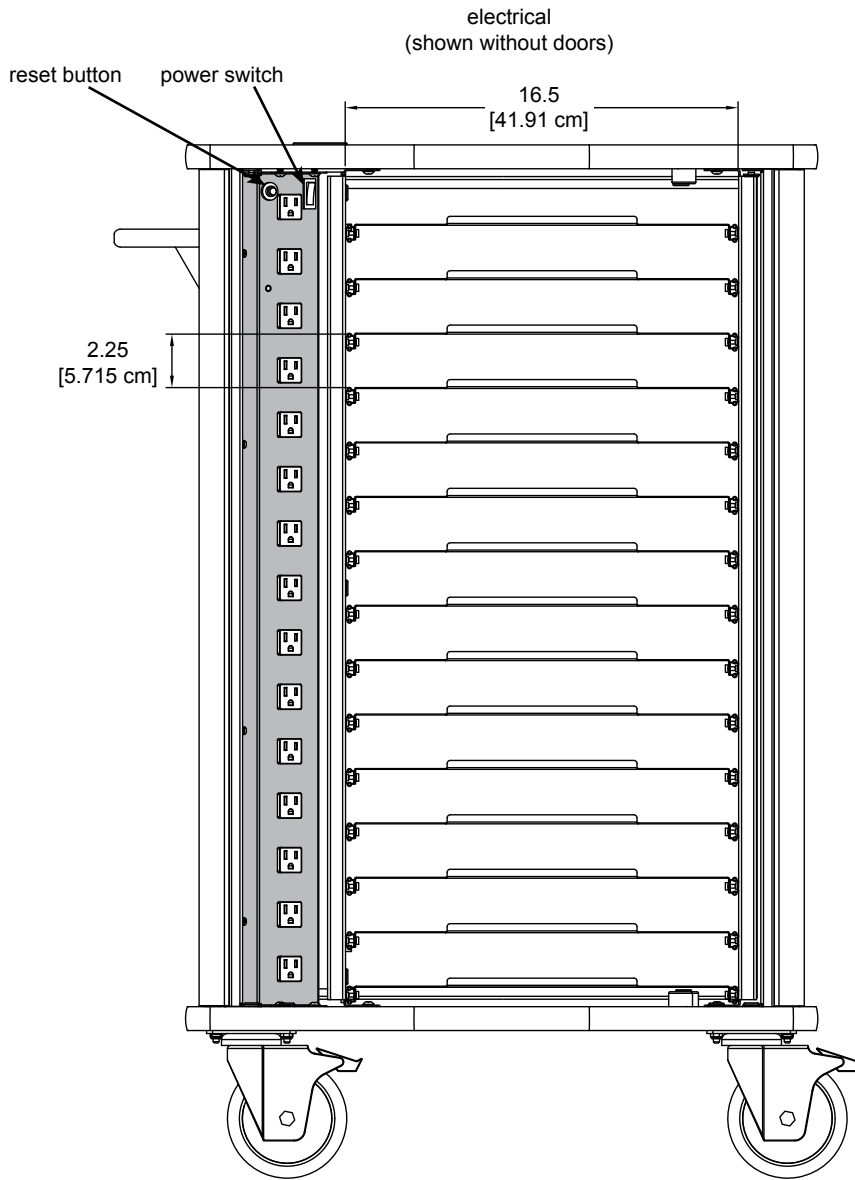

BW
5" Balloon Wheels (4 swivel)
Provides more maneuverability in tight spaces, but less control when mobile

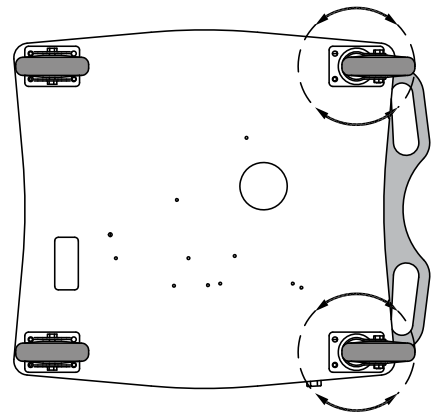

SR
5" Balloon Wheels (2 rigid, 2 swivel)
Provides more control when mobile, but less maneuverability in tight spaces

Note: If you have the SR version on your particular cart, mounting the handle on the same side as the two swivel wheels will provide more control of the cart when mobile.

Options

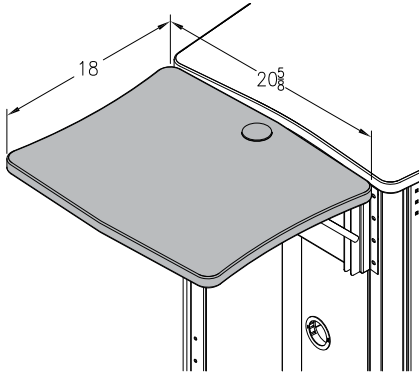

Flip-up Shelf
adjustable-height, mounts on left or right
18"W x 20.625"D
(50 lbs max capacity)
55219

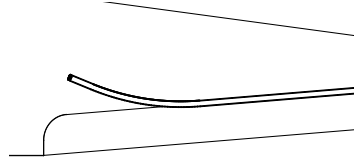

Tray Edge Trim
applies to shelf pull edge
30 pieces
55172



Velcro® Strap Kit
(16) .75" x 12", and (32) .75" x 5"
Velcro® straps
95004

Note: Power and communication wiring for document cameras, laptop computers, and/or projectors placed on the flip-up shelf should be routed on top of the audience-side of the shelf. Use of the shelf grommet hole for wiring will result in pinching of the cords when the shelf is folded.

Warranty

WE WILL MAKE IT RIGHT FOR YOU!

Spectrum is committed to provide complete customer satisfaction. Each of our products is manufactured from the best materials available and each product is stringently monitored throughout the production process through our P.A.C.E. program (Product Assurance to meet Customer Expectations).

We expressly warrant that Spectrum products will be of good quality and workmanship and free from defect for the period set out in the warranty table below from the date of delivery. This warranty shall not apply to defects or damage resulting from misuse, abuse, neglect, improper care, modification or repair not authorized by Spectrum, or any other cause outside the control of Spectrum. Spectrum will, at its sole option, either repair or replace the defective product.

This warranty is exclusive; no other warranty, written or oral, is expressed or implied. This warranty is given by Spectrum to Buyer and to no other person or legal entity. No Spectrum dealer, distributor, agent or employee is authorized to make any modification or addition to this warranty.

NOTWITHSTANDING ANYTHING TO THE CONTRARY, SPECTRUM WILL NOT UNDER ANY CIRCUMSTANCES BE LIABLE FOR INDIRECT OR LIQUIDATED DAMAGES, INCLUDING CONSEQUENTIAL, INCIDENTAL AND SPECIAL DAMAGES. IN NO EVENT SHALL SPECTRUM'S LIABILITY, WHETHER UNDER CONTRACT OR WARRANTY, IN TORT OR OTHERWISE, EXCEED THE PURCHASE PRICE RECEIVED BY SPECTRUM FOR THE PRODUCT AT ISSUE AND "RECALL ACTION" EXPENSES. SPECTRUM SHALL NOT BE SUBJECT TO ANY OTHER OBLIGATIONS OR LIABILITIES, WHETHER ARISING OUT OF BREACH OF CONTRACT, WARRANTY, TORT (INCLUDING NEGLIGENCE AND STRICT LIABILITY) OR OTHER THEORIES OF LAW, WITH RESPECT TO PRODUCTS SOLD OR SERVICES RENDERED BY SPECTRUM, OR ANY UNDERTAKINGS, ACTS OR OMISSIONS RELATING THERETO.

Our Customer Service Department is ready to provide immediate attention to any questions, comments or concerns. They are available to answer your calls Monday through Friday from 7 am to 5 pm CST. In addition your product comments or concerns are welcome via e-mail at: spectrum@spectrumfurniture.com.

Warranty Table

Item	Warranty Period
<ul style="list-style-type: none"> Adjustable Crank/Electric Desk Legs Flat Panel Desk Gas Cylinders 	<ul style="list-style-type: none"> 1 Year
<ul style="list-style-type: none"> Adjustable Height Chair Parts – including frames, gas cylinders, wood and plastic parts, and control handles Adjustable Height Chair Parts Casters Adjustable Height Chair Upholstery In-Stock Upholstery Graded-In Fabrics and Customer Owned Material 	<ul style="list-style-type: none"> 7 Years 2 Years 2 Years No Warranty
<ul style="list-style-type: none"> Height Adjustable Columns and Lifts General Use Casters Electrical Keyboard/Mouse Trays 	<ul style="list-style-type: none"> 1 Year
<ul style="list-style-type: none"> Flat Panel Monitor Arm – General Parts Flat Panel Monitor Arm – Gas Cylinders 	<ul style="list-style-type: none"> 5 Years 2 Years
<ul style="list-style-type: none"> Computer Desk Chassis Cart Chassis Lectern Chassis 	<ul style="list-style-type: none"> 10 Years

