

InVision Access Nano Table™

Touchboards

205 Westwood Ave, Long Branch, NJ 07740
Phone: 866-94 BOARDS (26273) / (732)-222-1511
Fax: (732)-222-7088 | E-mail: sales@touchboards.com

37129

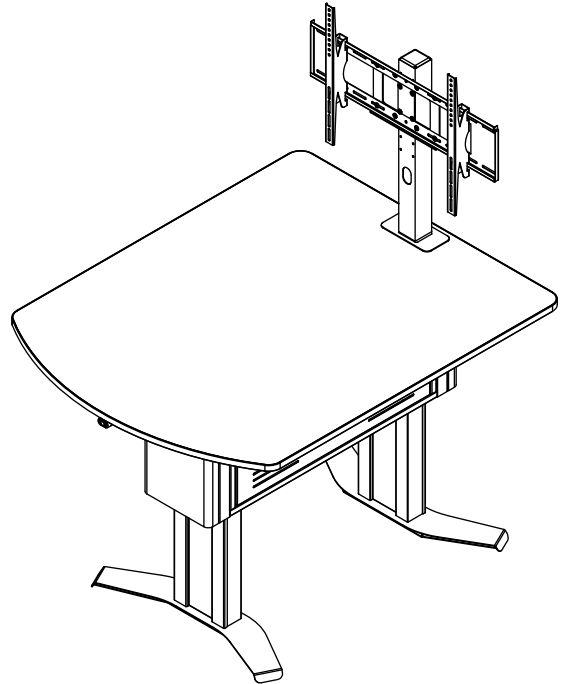
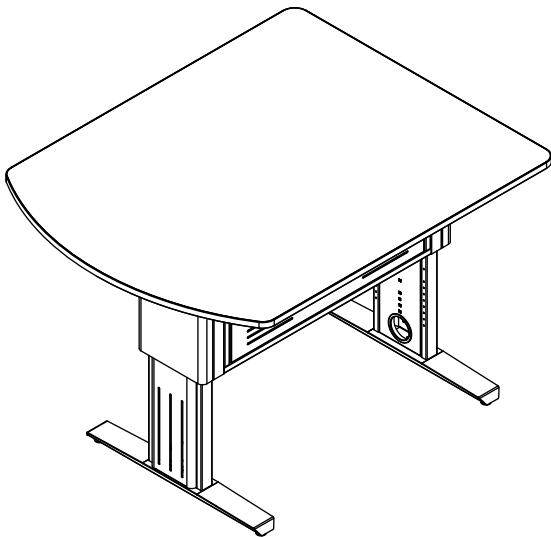

Shown with optional display stand

⚠ Important ⚠

Before using this product:

- Read this manual
- Comply with all safety and operating instructions
- Ensure all parts and correct quantities are included

Any parts damaged during shipment must be reported within 15 days of receipt. To report information regarding missing parts or damage, to purchase parts or accessories, or if you have any questions, please contact us.

Thank you for purchasing Spectrum products!

Spectrum Industries, Inc
925 First Avenue, Chippewa Falls, WI 54729 USA
800 235 1262
715 723 6750
www.spectrumfurniture.com



Important Safety and Care Instructions



- Read this owner's manual before assembly or operation.
- Do not allow children to move the table.
- For indoor use only. Do not install or store the table where it will be exposed to moisture.
- Do not block the ventilation openings.
- Do not allow anyone to sit, stand, or climb on the table.
- Use a damp, soft-cloth, or sponge, with mild soap or detergent solution to clean dirty surfaces. Do not use harsh solvents or abrasives.
- This table is intended for institutional use. It does not have any user-serviceable parts or user-maintenance requirements. If servicing is necessary, please contact Spectrum Industries for assistance.

Warning - Relocating audio and/or video equipment to furniture not specifically designed to support audio and/or video equipment may result in death or serious injury due to the furnishing collapsing or over turning onto a child.

Warning - Death or serious injury may occur when children climb on audio and/or video equipment furniture. A remote control or toys placed on the furnishing may encourage a child to climb on the furnishing and as a result the furnishing may tip over on to the child.

Electrical Safety:

- Keep the power switch in the OFF position before plugging or unplugging from the wall outlet.
- Ensure total device / equipment load does not exceed 12-amps.
- Do not plug the power cord into an extension cord.
- Inspect the power cords for damage before each use. Do not use power cords that are damaged.
- Unplug power cord from electrical outlet by gripping the cord. Do not unplug the power cord by pulling only on the cord.
- Do not step on, drive over, drag, or place objects on the power cord.
- For added safety, plug the cart into a grounded outlet controlled by a GFI (Ground Fault Interrupter) circuit breaker.
- Damaged electrical components can create significant hazards to users and is not covered by the warranty. Repairs should always be performed by a qualified electrician.
- Electrical devices are not toys. Children are often unaware of the hazards associated with electrical devices. This table must always be used by adults or with adult supervision.

Components

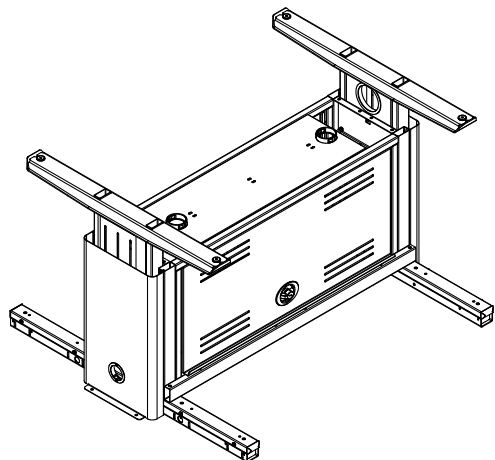

(1) 0116814
Table core with set and go legs
(shipping position shown)

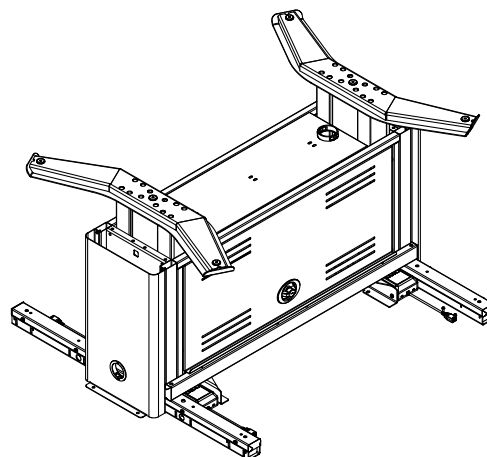

(1) 0116818
Table core with eLift legs
(shipping position shown)

Hardware



(1) 0109398
Control button
bracket



(2) 037542
#8 x 5/8"
PHSM



(1) 0109397
Control button



(2) 0107023
Snap-in pine
tree clip



(2) 037779
5/16-18 Glide

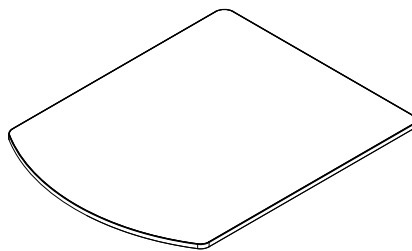

(1) Worksurface

Hardware



(4) 037779
5/16-18 Glide

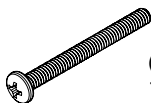

(8) 021551
1/4-20 x 2-3/4"
PHMS



(2) 0101382
#14 x 7/8" PHSM



(2) 026064
1/4-20 x 5/8" PHMS

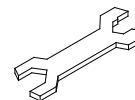

(1) 025069
Glide wrench

Assembly / Setup

1. Unpack & detach from pallet

1. Remove outer sleeve. **Figure 1A.**
2. Unscrew the (4) Phillips head wood screws securing the table core to the pallet. **Figure 1B.**
3. Without using a utility knife, open the rest of the boxes.

Tools Required

- Phillips screwdriver
- or
- Cordless drill with long magnetic Phillips driver (best)

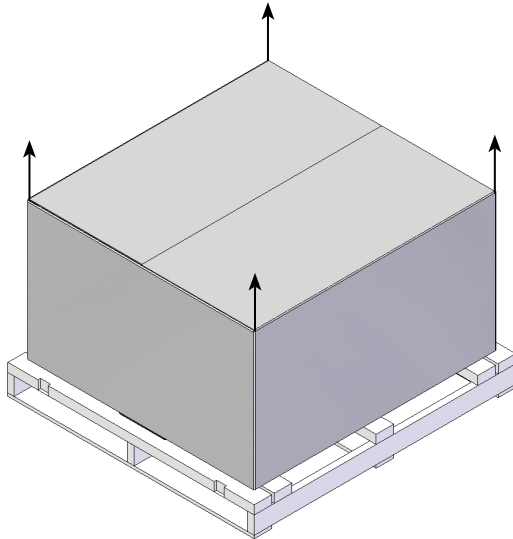

Figure 1A

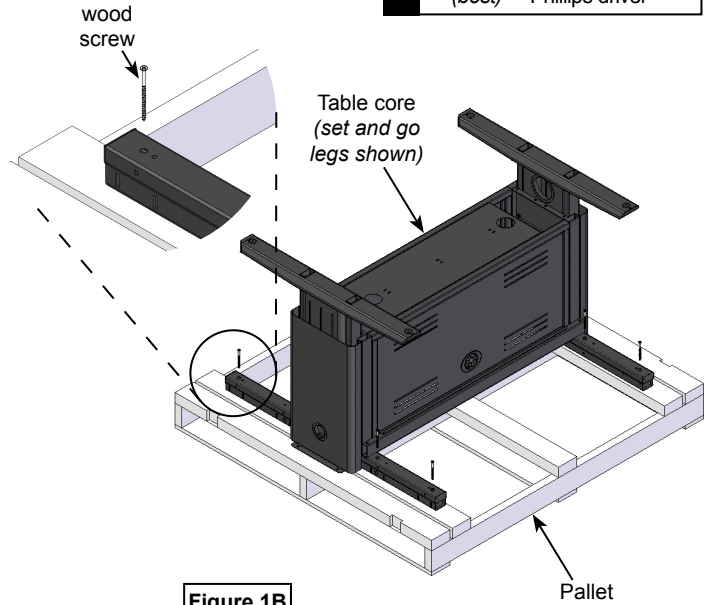

Figure 1B

2. Install glides

1. With the table core still upside-down, install the glides onto the legs (4) on Set and go legs, (6) on eLift legs. **Figure 2.**

Tools Required

- Glide wrench (included)

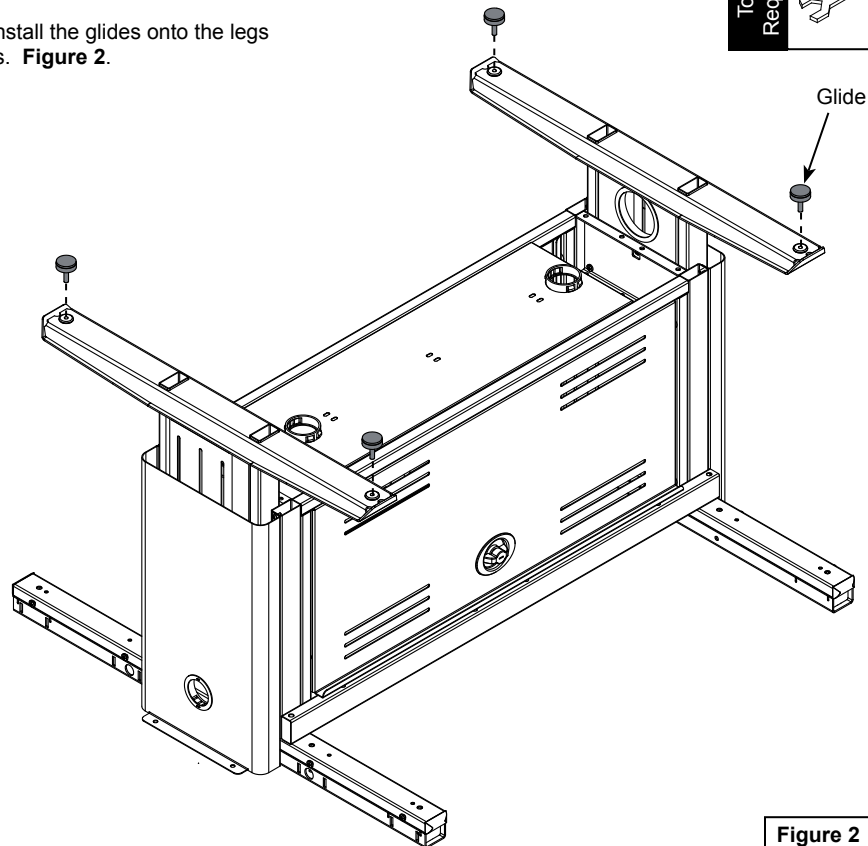

Figure 2

3. Adjust leg height (Set and go legs only)

Note: If you have a table with eLift legs, proceed to step 4.

Tables with adjustable-height set and go legs can be adjusted to have a worksurface height between 29"- 42" (in 1" or 2" increments). **Figure 3A.** The factory-set height is 29"H. Adjustment to the leg height should be done while the table is still upside-down on the pallet.

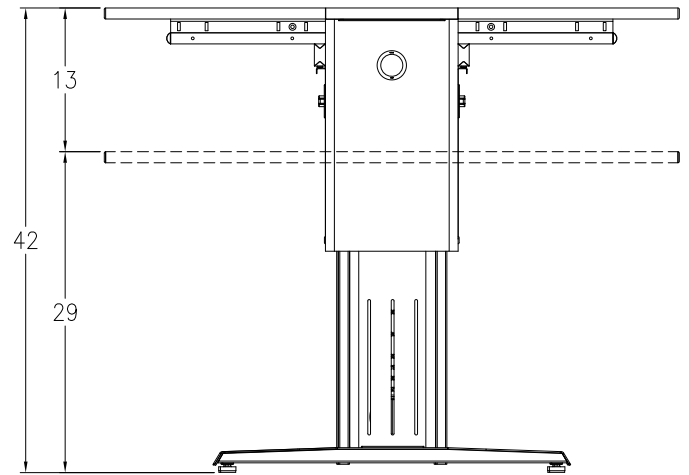
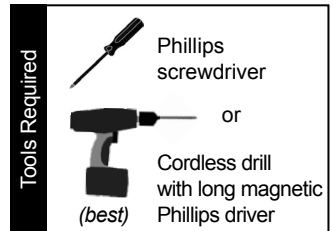

Figure 3A

To adjust leg height:

1. Remove both side panels to provide access. **Figure 3B.**
2. Locate and remove the (4) 1/4-20 x 5/8" PHM screws that secure the Set and go leg. While these screws are removed, have a helper support the detached leg.
3. Locate the height indicator window and slide the leg to the desired height setting.
4. Replace the (4) 1/4-20 x 5/8" PHM screws and tighten securely.
5. Repeat on the second leg using the same height setting.

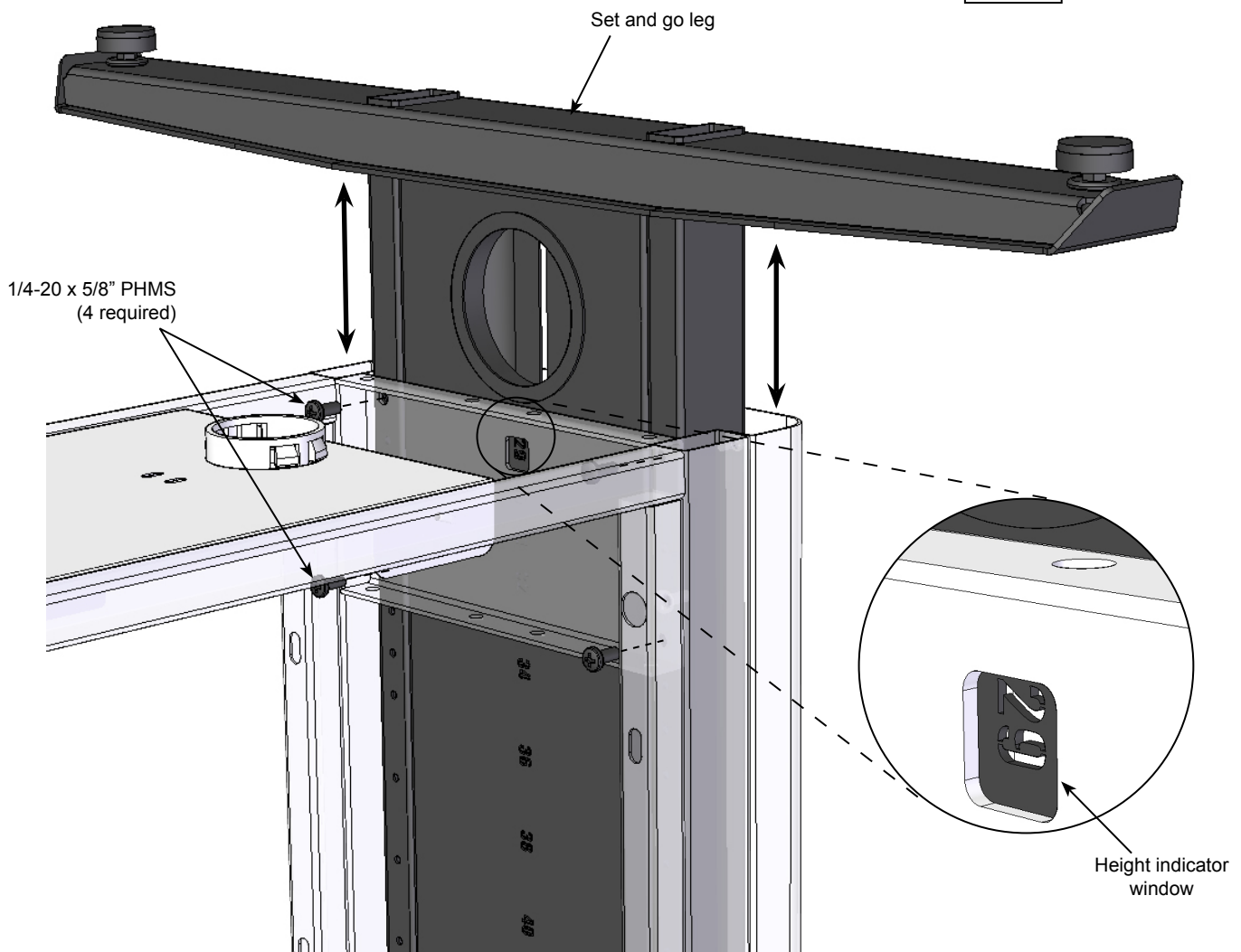

Figure 3B

4. Flip Core upright

1. Carefully flip the table core upright-this will take 3-4 people. **Figure 4.**

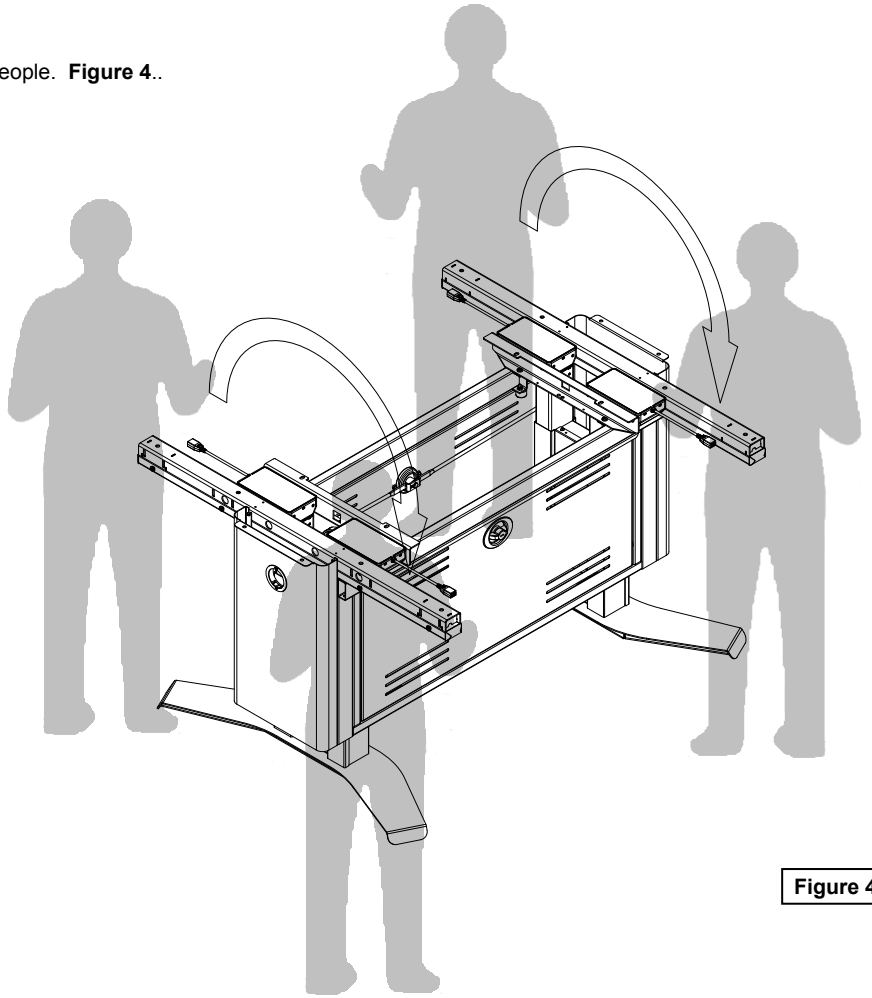

Figure 4

5. Install worksurface

1. Set the worksurface onto the the core and align the mounting holes.
Figure 5.
2. Attach the worksurface using (8) 1/4-20 x 2-3/4" PHM screws.

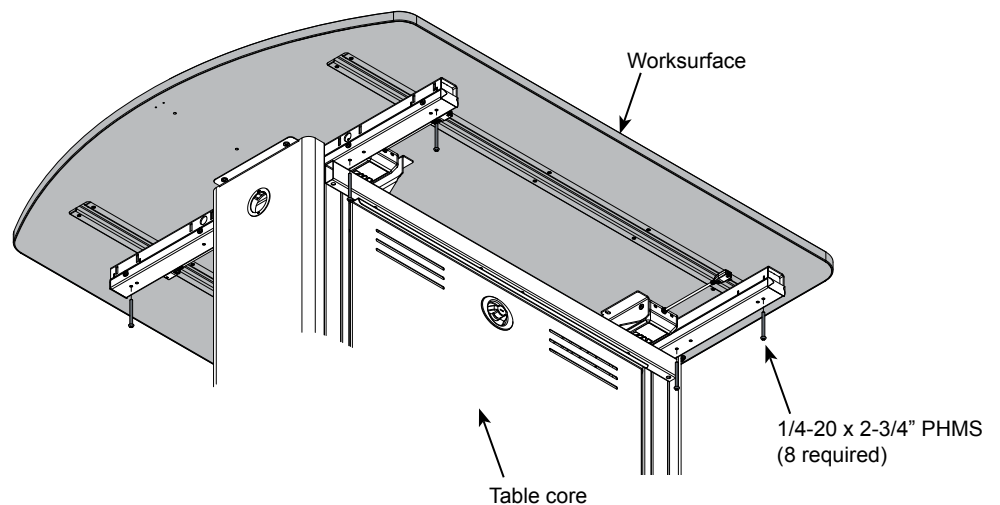

Figure 5

6. Display Stand

If you have the optional display stand, proceed with the installation at this time. **Figure 6.** (Instructions included with stand.)

Cord management options

Cords and wiring from any worksurface devices can be routed cleanly throughout the unit using grommet holes and openings in the bottom of the technology compartment.

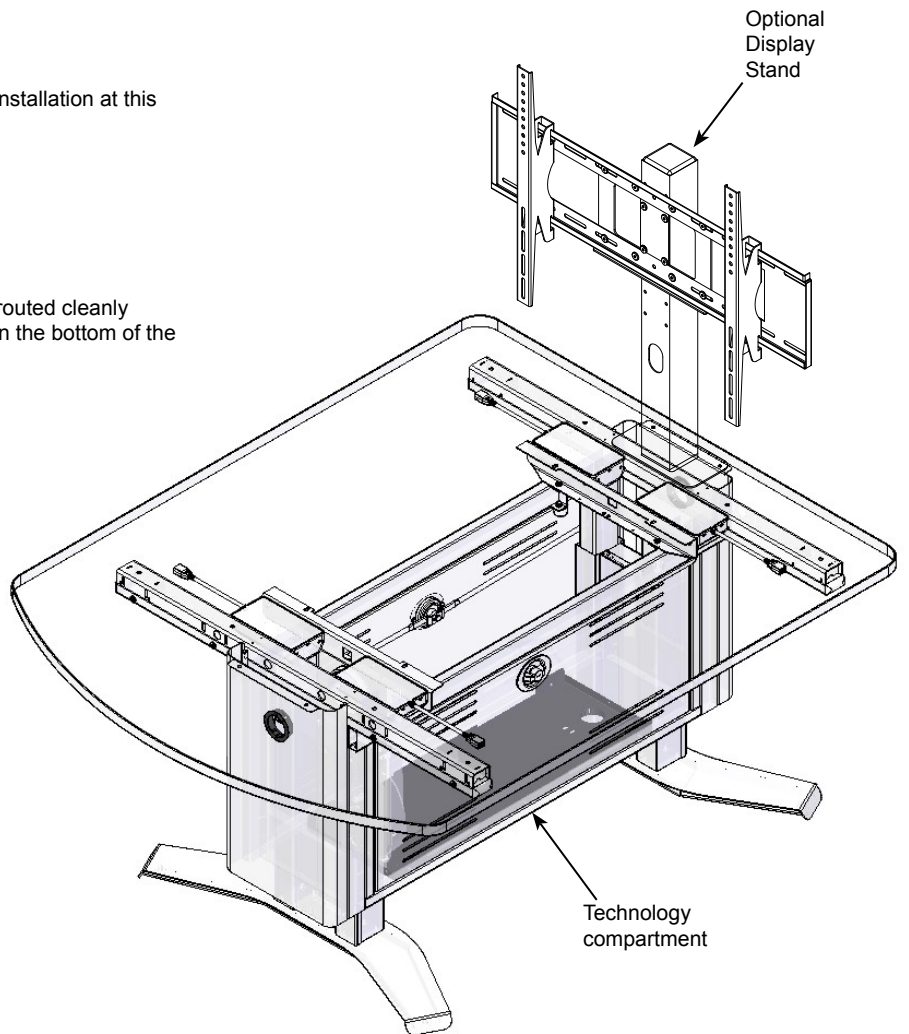

Figure 6

Side panel stop adjustment

If necessary, the offset panel stops can be adjusted to slightly shift the closed position of the panels and lock rods.

1. Loosen the JC bolt slightly with a 4mm hex wrench. **Figure 7.**
2. Rotate the stop until the panel is positioned correctly. Be sure the lock rods engage easily.
3. Re-tighten the JC bolt securely.

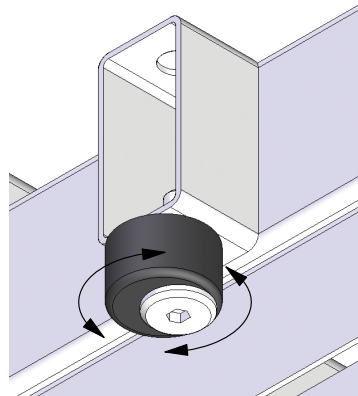

Figure 7

eLift operating instructions - eLift equipped tables only



1. Attach the control button bracket under the radiused portion of the worksurface with (2) #8 x 5/8" PHSM screws and pre-drilled pilot holes in the center of the worksurface.
2. Push the control button onto the bracket.
3. Use the included pine tree clips to secure the cord to the worksurface.

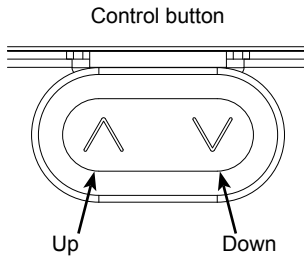

Figure 8A

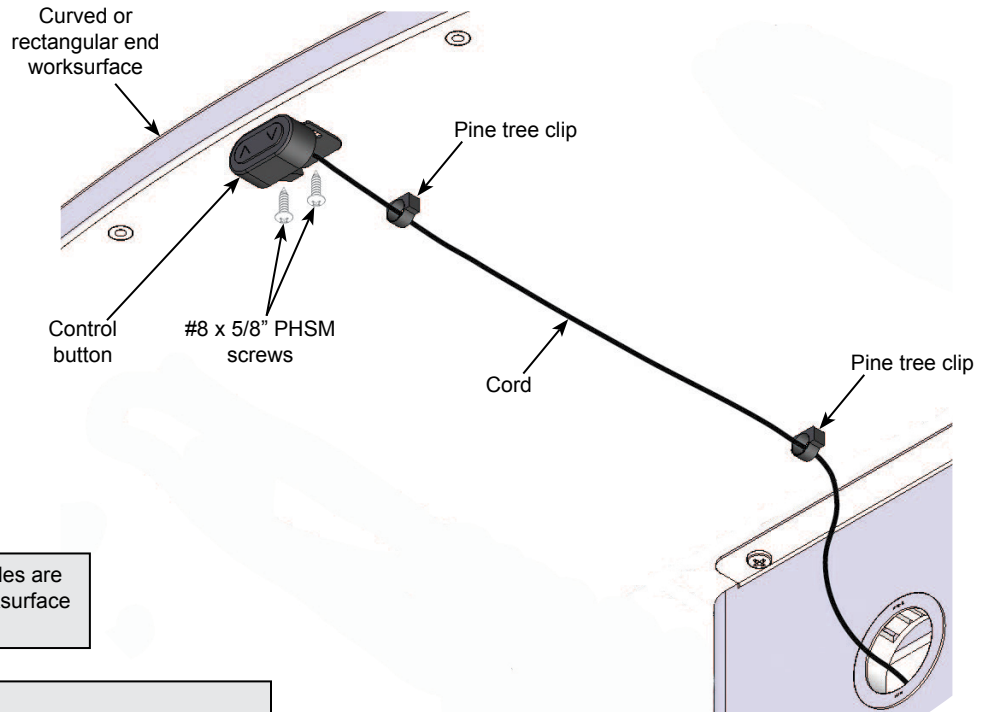

Figure 8B

Note: Additional sets of pre-drilled mounting holes are available under the straight sections of the worksurface to mount the control button if preferred.

Operation:

1. Plug the 11-foot, 15-amp power cord into a wall outlet.
2. Locate the "Up" and "Down" buttons on the control pad.
3. To raise or lower the worksurface, press and hold the "up" or "down" arrow keys on the control pad until the worksurface reaches the desired height. The worksurface maximum height is 42", minimum height is 29".

Keep clear of pinch points during worksurface movement.

Reset Procedure:

1. Unplug, then re-plug the power cord into a wall outlet.
2. Make sure all lift mechanism wire connections are in place and secure.
3. Remove anything located under the worksurface.
4. Press and hold the "Down" button to lower the worksurface to the lowest "work" position until it stops moving.
5. Release the "Down" button.
6. Press and hold the "Down" button again until the worksurface bottoms-out, slightly rises, and stops moving. The worksurface must be completely lowered before resuming operation.

Note: If the worksurface does not lower when doing this step, release the "Down" button, and retry step 6.

7. Release the "Down" button. The lift mechanism has now been reset and the worksurface can be adjusted normally.



CAUTION

Keep clear of pinch points during worksurface movement.
Note: The lift actuators are rated at a maximum capacity of 180 lb each.



CAUTION

Always unplug the eLift before working under the worksurface.

Although this table utilizes an anti-collision feature that briefly stops and reverses the motion of the table in the event of an obstruction, **Use caution when raising or lowering the worksurface! Do not** sit at, under, or on the worksurface when operating the lift mechanism and be sure table movement does not interfere with objects or people.



CAUTION

USE CAUTION WHEN RAISING OR LOWERING TABLE!

Element Display Stand - 37130

- Bolts directly to worksurface
- Integrated cable management routes and hides wires
- Adjustable (VESA-compatible) mount
- Requires worksurface mounting holes and cutout

Monitor size range:	32"-55" [81.3 cm-139.7 cm] diagonal	
Weight capacity:	100 lb [45.4 kg]	
Vertical adjustment (worksurface-to-center)	• 23.5"H [59.7 cm]	(5 vertical positions in 2" increments)
	• 21.5"H [54.6 cm]	
	• 19.5"H [49.5 cm]	
	• 17.5"H [44.5 cm]	
	• 15.5"H [39.4 cm]	
Tilting	15° range	
Shipping weight:	35 lb [15.9 kg]	

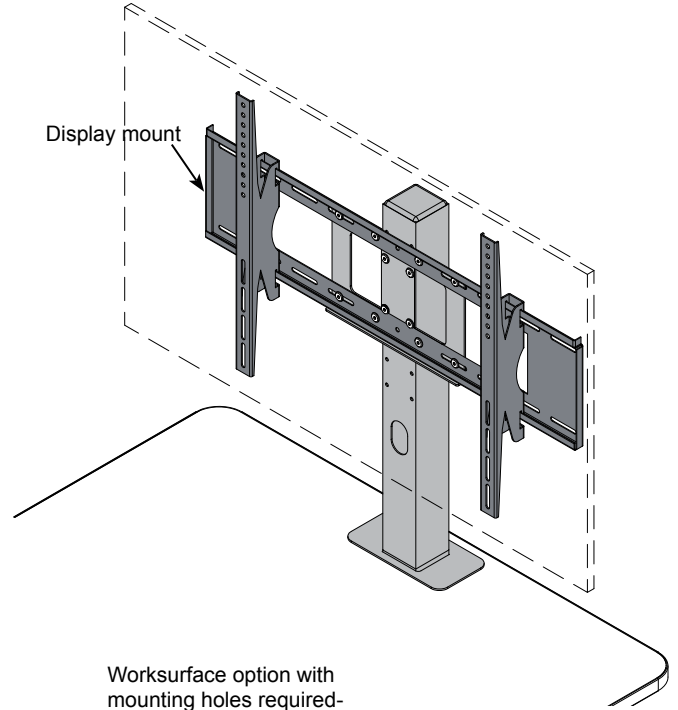

Worksurface option with mounting holes required-specify when ordering

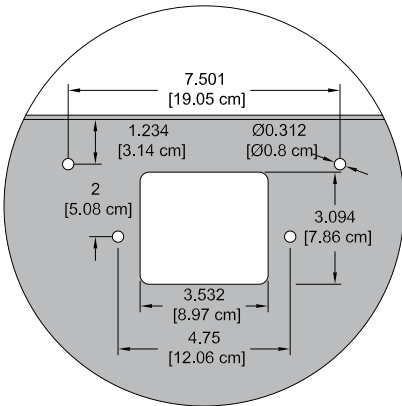

Mounting holes and cutouts needed on flat end of worksurface

Cove Power Module - 99044

- Two power receptacles per module
- Two USB charge ports (not data-compatible)
- Thumbscrew clamps
- Requires worksurface cutout
- ETL listed
- Available in Black or Silver

Cutout required:	5.25"W [13.3 cm] x 2"D [5.1 cm] (mounts to surface thicknesses up to 1.5")
Power cord:	9' [274 cm] with 90° flat plug with 45° rotation
Power receptacles:	12A, 120 VAC spill-resistant
USB charging ports:	2.1A (10.5W)
Dimensions:	6"W [15.2 cm] x 2.5"D [6.35 cm] x 3.18"H [8.1 cm]
Unit weight:	2.29 lb [1 kg]

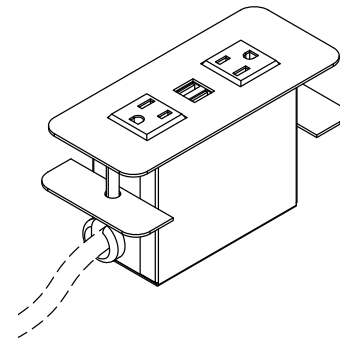

Electric leg information

Warning!

Failure to comply with these instructions may result in accidents involving serious personal injury. Failing to follow these instructions can result in the product being damaged or being destroyed.

Safety Information

General

Safe use of the system is possible only when the operating instructions are read completely and the instructions contained are strictly observed. Failure to comply with instructions marked with the "NOTE" symbol may result in serious damage to the system or one of its components.

- It is important for everyone who is to connect, install, or use the systems to have the necessary information and access to the Owners Manual. Follow the instructions for mounting – risk of injury if these instructions are not followed.
- The appliance is not intended for use by young children or infirm persons without supervision.
- If there is visible damage on the product it must not be installed.
- Note that during construction of applications, in which the actuator is to be fitted, there must be no possibility of personal injury, for example the squeezing of fingers or arms.



Assure free space for movement of application in both directions to avoid blockage.

Before installation, re-installation, or troubleshooting:

- Stop the DL5/DL6
- Pull out the mains plug.
- Relieve the DL5/DL6 of any loads, which may be released during the work.

Before start-up:

- Make sure that the system has been installed as instructed in this User Manual.
- Make sure that the voltage of the control box is correct before the system is connected to the mains.
- System connection. The individual parts must be connected before the control box is connected to the mains. See the User Manual for LINAK actuators, if necessary.

During operation

- If the control box makes unusual noise or smells, switch off the mains voltage immediately.
- Take care that the cables are not damaged.
- Unplug the mains cable on mobile equipment before it is moved.
- The products must only be used in an environment, that corresponds to their IP protection.

Misc.

The actuator system has a sound level below 55dB(A) in typical applications. Updated manuals and declarations can always be found here: www.linak.com/desklined

DL6



Only for EU markets

- This appliance can be used by children aged from 8 years and above and persons with reduced physical, sensory or mental capabilities or lack of experience and knowledge if they have given supervision or instruction concerning use of the appliance in a safe way and understand the hazards involved.
- Children shall not play with the appliance. Cleaning and user maintenance shall not be made by children without supervision.

Only for Non-EU markets

- Persons who do not have the necessary experience or knowledge of the product/products must not use the product/products. Besides, persons with reduced physical, sensory or mental abilities must not use the product/products, unless they are under surveillance or they have been thoroughly instructed in the use of the apparatus by a person who is responsible for the safety of these persons.
- Moreover, children must be under surveillance to ensure that they do not play with the product.
- It is the operator's responsibility to ensure that there is free space for the application to move without risk for the operator or bystanders before operating the application.

Misuse

- Do not overload the actuators – this can cause danger of personal injury and damage to the system.
- Do not use the actuator system for lifting persons. Do not sit or stand on a table while operating – risk of personal injury.
- Do not use the system in environments other than the intended indoor use.

Repairs

In order to avoid the risk of malfunction, all DESKLINE® repairs must only be carried out by authorised LINAK workshops or repairers, as special tools must be used and special gaskets must be fitted. Lifting units under warranty must also be returned to authorised LINAK workshops.

Warning! If any of the DESKLINE® products are opened, there will be a risk of subsequent malfunction.

Warning! The DESKLINE® systems do not withstand cutting oil.

CBD4

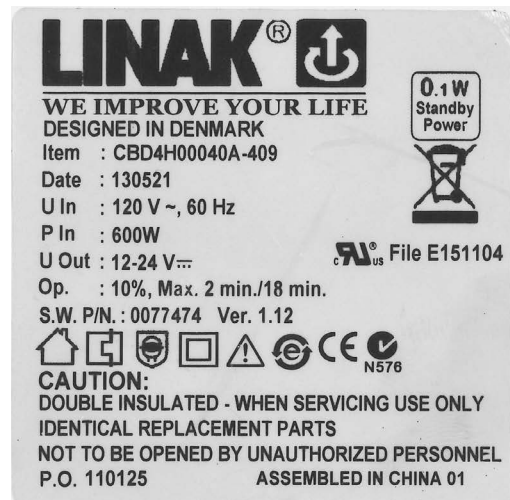

Misc. on the DESKLINE® DL5/DL6 system

This system is a DESKLINE system developed for desks and for indoor use in offices. Do not use it in industrial kitchens or in other environments that have to be cleaned with aggressive detergents. Do not bolt the legs to the floor so that free movement is prevented. This could cause serious damage to the legs in fault situations.

Warranty

There is a 36 months' warranty on the DESKLINE products against manufacturing faults from the production date of the individual products (see label). LINAK A/S' warranty is only valid in so far as the equipment has been used and maintained correctly and has not been tampered with. Furthermore, the system must not be exposed to violent treatment. In the event of this, the warranty will be ineffective/invalid. For further details, please see LINAK A/S ordinary conditions of sale.

Maintenance

Clean dust and dirt on the outside of the system at appropriate intervals and inspect them for damage and breaks. Inspect the connections, cables, and plugs and check for correct functioning as well as fixing points.

Service of double-insulated products:

Class II

A Class II or **double insulated** electrical appliance is one which has been designed in such a way that it does not require a safety connection to electrical earth (US: ground).

The basic requirement is that no single failure can result in dangerous voltage becoming exposed so that it might cause an electric shock and that this is achieved without relying on an earthed metal casing. This is usually achieved at least in part by having two layers of insulating material surrounding live parts or by using reinforced insulation. There is no earthing/grounding means provided on the product, and no earthing/grounding means is to be added to the product.

In Europe, a double insulated appliance must be labelled "Class II", "double insulated" or bear the double insulation symbol (a square inside another square).

Servicing a double-insulated product requires extreme care and knowledge of the system, and is to be done only by qualified service personnel. Replacement parts for a double-insulated product must be identical to the parts they replace.

 **The cleaners and disinfectants must not be highly alkaline or acidic (pH value 6-8).**

Description of the DESKLINE® DL5/DL6 system

Each DESKLINE® DL5/DL6 lifting units is equipped with a motor and parallel/memory drive is ensured by means of software in the CBD4/CBD5/CBD6 that also takes account of oblique load on the desk. Soft start and stop are also part of this software, which ensures a soft start and stop when adjusting the desk.

Application of the DESKLINE® DL5/DL6 system:

Irrespective of the load the **duty cycle 10% ~ 6 min./ hour or max. 2 min. at continuous use** stated in the data sheets, must **NOT** be exceeded as this will result in a superheating of the motor, the brake and the spindle nut. Exceeding the duty cycle will result in a dramatic reduction of the life of the system.

The DESKLINE® DL5/DL6 system range contains the following products:

- 1 control box CBD4/CBD5/CBD6
- 1 single DL5/DL6 or 2, 3, or 4 parallel
- 1 exchangeable mains cable
- 1, 2, 3, or 4 motor cables
- 1 DP1U/DPF1M (if memory function is required) DP1C/WDPL/DPT/DPF1C (if memory function and display is required) or 1 DPA/DPB/DP1K/DP1V/DPF1K (if only up/down is required.)

Electrical connection of the DL5/DL6 system

The DESKLINE® DL5/DL6 system is to be connected as shown on figure 4. Each DL5/DL6 is to be connected to the sockets on the control box by means of the motor cables, which have an 6-pin plug in each end. Finally, the mains cable is to be mounted and power switched on.

 Please note that the control box must only be connected to the voltage stated on the label.

CBD4/CBD5/CBD6 with earth

The CBD4/CBD5/CBD6 earth cable to be mounted on the desk construction (typically the top frame) in a way that ensures good electrical contact. The function of the earth cable is to earth the desk and ground static electricity. The earth connection does not protect other electrical products.

CBD4/CBD5 with mains cut-off (non ZERO models)

If the power cable is damaged it has to be replaced by an authorized LINAK service centre to avoid any danger.

DL5/DL6 cable

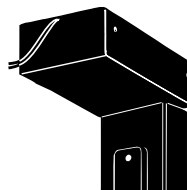

DL5/DL6

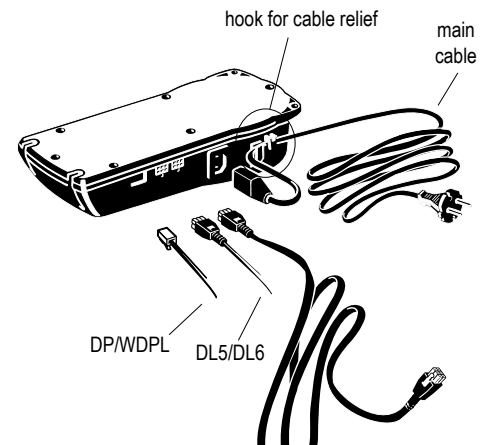

Anti-Collision™

The function (anti-collision) is an option for the standard CBD4/CBD5/CBD6 advanced/control box software 0077432 version 1.66 and later. A system with anti-collision can limit material damages on a desk if a collision with a solid object should occur

Method of operation

When the DL/DB's are running the CBD4/CBD5/CBD6 monitors the current consumption on each channel using a special algorithm. If the current consumption on one channel is increased more than a predefined slope, a collision is assumed and all channels are stopped immediately and all DL/DB's will start to run in the opposite direction (approx. 50 mm). This return drive is done automatically and continues with or without any control key pressed (for max. 2.5 sec.).

The anti-collision sensitivity is different in upward and downward direction. Upwards the force is approx. 20 kg. Downwards the load will be approx. 40 kg + the load on the DL/DB (the desk + what is on top of the desk). The 40 kg are needed to activate the anti-collision function.

Situations where the anti-collision does not work

There are situations where the anti-collision will not be activated. These situations are:

- If the collision happens during the initialisation phase
- If the collision happens within the first 1000 msec or after the control button has been released
- If the collision happens between the floor and the table and the load on the desk + the weight of the legs are lower than 40 kg
- If the collision happens over too long time, e.g. if the collision is with a soft object.

eLift Leg Troubleshooting Guide

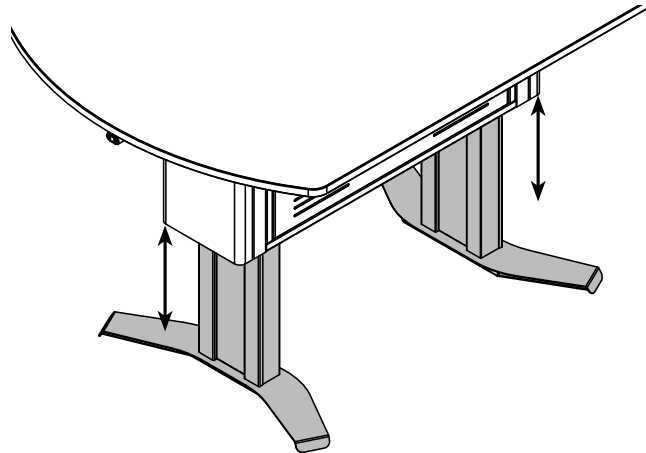

Symptom	Problem	Solution
eLift legs will not operate	Loss of power	Be sure unit is plugged into a live circuit.
	Loose electrical connections	Make sure all electrical connections are securely plugged into the control box.
	Object encountered under work surface	<ol style="list-style-type: none"> 1. Raise the work surface by pressing the "Up" button. 2. Remove any items sitting below the work surface. 3. Reset the lift mechanism (see below for procedure.)
	Misaligned actuators	<p style="text-align: center;"><u>Reset Procedure:</u></p> <div style="border: 1px solid black; padding: 5px; margin-bottom: 10px;"> <p>This table has a load-sensing, anti-collision feature in the controller that actively locks out the lift mechanism when unbalanced loads are encountered; i.e. weight from a person sitting on one side of the table. The following reset procedure should be performed if the lift mechanism becomes locked out and the table does not extend or retract.</p> </div> <div style="border: 1px solid black; padding: 5px; margin-bottom: 10px; text-align: center;"> <p>⚠ WARNING ⚠</p> <p>The anti-collision feature does not function in RESET MODE. Do not sit at, under, or on the work surface while resetting the lift mechanism. Be sure the table movement does not interfere with objects or people. Do not place <u>any</u> items under the work surface.</p> </div> <ol style="list-style-type: none"> 1. Unplug, then re-plug the power cord into a wall outlet. 2. Make sure all lift mechanism wire connections are in place and secure. 3. Remove <u>anything</u> located under the work surface. 4. Press and hold the "Down" button to lower the work surface to the lowest "work" position until it stops moving. 5. Release the "Down" button. 6. Press and hold the "Down" button again until the work surface bottoms-out, slightly rises, and stops moving. The work surface must be completely lowered before resuming operation. <p>Note: If the work surface does not lower when doing this step, release the "Down" button, and retry step 6.</p> <ol style="list-style-type: none"> 7. Release the "Down" button. The lift mechanism has now been reset and the work surface can be adjusted normally.

Warranty

WE WILL MAKE IT RIGHT FOR YOU!

Spectrum is committed to provide complete customer satisfaction. Each of our products is manufactured from the best materials available and each product is stringently monitored throughout the production process through our P.A.C.E. program (Product Assurance to meet Customer Expectations).

We expressly warrant that Spectrum products will be of good quality and workmanship and free from defect for the period set out in the warranty table below from the date of delivery. This warranty shall not apply to defects or damage resulting from misuse, abuse, neglect, improper care, modification or repair not authorized by Spectrum, or any other cause outside the control of Spectrum. Spectrum will, at its sole option, either repair or replace the defective product.

This warranty is exclusive; no other warranty, written or oral, is expressed or implied. This warranty is given by Spectrum to Buyer and to no other person or legal entity. No Spectrum dealer, distributor, agent or employee is authorized to make any modification or addition to this warranty.

NOTWITHSTANDING ANYTHING TO THE CONTRARY, SPECTRUM WILL NOT UNDER ANY CIRCUMSTANCES BE LIABLE FOR INDIRECT OR LIQUIDATED DAMAGES, INCLUDING CONSEQUENTIAL, INCIDENTAL AND SPECIAL DAMAGES. IN NO EVENT SHALL SPECTRUM'S LIABILITY, WHETHER UNDER CONTRACT OR WARRANTY, IN TORT OR OTHERWISE, EXCEED THE PURCHASE PRICE RECEIVED BY SPECTRUM FOR THE PRODUCT AT ISSUE AND "RECALL ACTION" EXPENSES. SPECTRUM SHALL NOT BE SUBJECT TO ANY OTHER OBLIGATIONS OR LIABILITIES, WHETHER ARISING OUT OF BREACH OF CONTRACT, WARRANTY, TORT (INCLUDING NEGLIGENCE AND STRICT LIABILITY) OR OTHER THEORIES OF LAW, WITH RESPECT TO PRODUCTS SOLD OR SERVICES RENDERED BY SPECTRUM, OR ANY UNDERTAKINGS, ACTS OR OMISSIONS RELATING THERETO.

Our Customer Service Department is ready to provide immediate attention to any questions, comments or concerns. They are available to answer your calls Monday through Friday from 7 am to 5 pm CST. In addition your product comments or concerns are welcome via e-mail at: spectrum@spectrumfurniture.com.

Warranty Table

effective 1/1/2015

Item	Warranty Period
Adjustable Crank / Electric Desk Legs	• 1 Year
Flat Panel Desk Gas Cylinders	
Chairs <ul style="list-style-type: none"> • Adjustable Height Chair Parts – including frames, gas cylinders, wood and plastic parts, control handles, casters • Adjustable Height Chair Upholstery • In-Stock Upholstery • Graded-In Fabrics and Customer Owned Material 	<ul style="list-style-type: none"> • 7 Years • 2 Years • 2 Years • No Warranty
Height Adjustable Columns and Lifts	• 1 Year
General Use Casters	
Electrical (including timers and LINAK actuators)	• 2 Years
Keyboard / Mouse Trays	• 1 Year
Flat Panel Monitor Arms <ul style="list-style-type: none"> • Flat Panel Monitor Arm – General Parts • Flat Panel Monitor Arm – Gas Cylinders 	<ul style="list-style-type: none"> • 5 Years • 2 Years
Desks and Lecterns <ul style="list-style-type: none"> • Computer Desk Chassis • Cart Chassis • Lectern Chassis 	• 10 Years

