

Technical Specifications

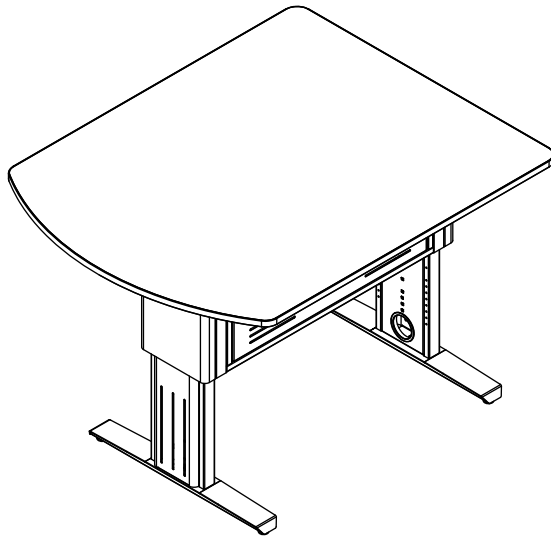

205 Westwood Ave, Long Branch, NJ 07740
Phone: 866-94 BOARDS (26273) / (732)-222-1511
Fax: (732)-222-7088 | E-mail: sales@touchboards.com

37129



InVision Access Nano Table
(Set and go legs shown)

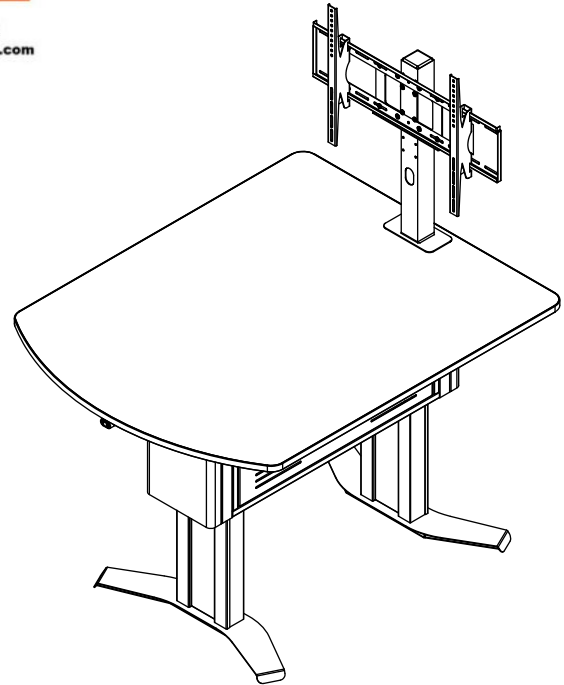

InVision Access Nano Table
(Display stand and eLift legs shown)

The InVision Access Nano Table is the next generation of active learning classroom and collaboration space furniture. Like the other InVision Collaboration Tables, the Access Table can mount a large screen monitor and has a lot of space for communication and sharing technology securely mounted in the 48" x 60" table. Three different leg options give the user the opportunity to choose the height of the table. The Set and go legs can be assembled to the desired worksurface height from 29 to 42 inches for sitting, standing or any height in between, and the height can be changed in the future if desired. The electric adjustable eLift Legs can be adjusted with a push of a button for on-demand worksurface height adjustment.

Features and Benefits

- One-piece worksurface with matching color edge trim
- Choose from Set and go (selectable worksurface height during assembly), or eLift electric (adjustable-height worksurface) versions
- One-piece worksurface with matching color edge trim
- Scratch and impact-resistant high-pressure laminate worksurface
- Durable powder coated steel chassis provides a long-lasting finish
- Durable worksurface edge trim
- Technology compartment / cord channel provides secure internal space for most popular A/V equipment and doubles as a worksurface support to minimize flexing
- ADA-compliant knee clearance under worksurface
- Leveling glides keep table level on uneven surfaces
- Cords and wiring can be channeled cleanly throughout the unit using grommet holes and openings in the bottom of the technology compartment / cord channel
- Removable, ventilated, locking access panels with double-bolt, keyed locks provide security, easy access, and cooling to internal equipment
- Table ships "knocked-down" and can be assembled at the final location for easy installation and lower shipping costs
- Optional display stand provides ability to attach most monitors (requires worksurface mounting holes and cutout)
- SCS Indoor Advantage Certified; meets or exceeds applicable ANSI-BIFMA test standards
- Warranted to be free of all defects in materials and workmanship for 10 years, electrical system 2 years
- Manufactured in Chippewa Falls, WI, USA

Color Options
See spectrumfurniture.com for complete color options and combinations.

Construction

- The worksurfaces are constructed from 1" thick NAUF (No Added Urea Formaldehyde) composite board plus .030" high-pressure laminate on one face, and a balancing phenolic backer on the opposing face
- Metal components consist of 12, 16, and 20-gauge steel
- Worksurface edges are covered with 3mm vinyl (color matching)
- All metal components are finished with a scratch-resistant powder coat epoxy
- Tables are shipped KD (Knocked-Down) and require assembly

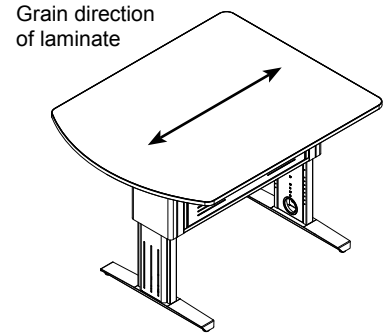

Specifications

Worksurface height adjustability	<ul style="list-style-type: none"> • Set and go legs - 29-42"H [73.66-106.68 cm] in 1" and 2" increments (<i>adjustable at time of assembly</i>) (height settings available: 29", 30", 31", 32", 34", 36", 40", 42") • eLift electric legs - 29-42"H [73.66-106.68 cm]
Available worksurface cutout area	<ul style="list-style-type: none"> • 37.625"W [93.98 cm] x 10"D [25.4 cm] (Set and go legs) • 27.188"W [69 cm] x 10"D [25.4 cm] (eLift electric legs)
Internal area of technology compartment / cord channel (nominal)	35.625"W [90.5 cm] x 9.875"D [25 cm] x 13.938"H [35.4 cm]
Seating	See possibilities below
ADA-compliance*	Each table supports (2) ADA-compliant seating positions <small>*Minimum ADA guidelines for knee clearances are 30"W [76.2 cm] x 19"D [48.3 cm] x 27"H [68.6 cm]</small>
eLift electric legs	<ul style="list-style-type: none"> • Range of motion: 13" [33 cm] in approximately 10 seconds • 4 actuators • Inverter: 120V @ 60Hz, max output 400 watts • Motors: 18V / 10 amps • Typical electrical load during operation: 4.3 amps @ 120 VAC • Anti-collision protection for safety • 11' [335 cm] nominal 3-wire power cord • Max load: 1200N (270 lb) [122.6 kg] per actuator total lift capacity: 1080 lb [490 kg] • Actuators feature non-hydraulic, permanently lubricated screw jacks • Actuators rated for 20,000 cycles • Tested at 1000 cycles at 300 lb • Approved according to EN 60335-1 and UL 962
Shipping weights (nominal)	N/A



Specifications subject to change without notice

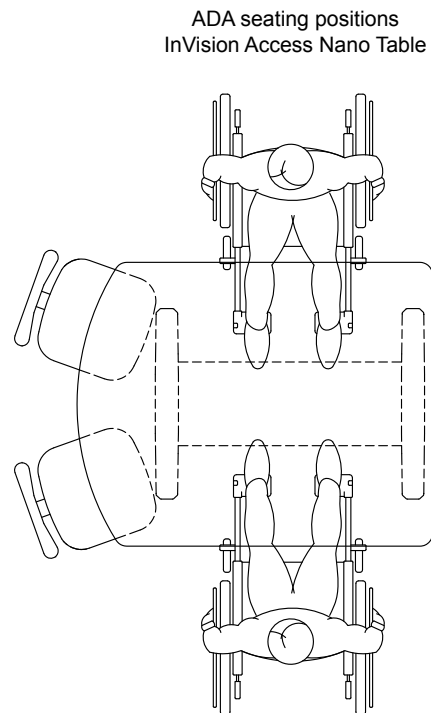
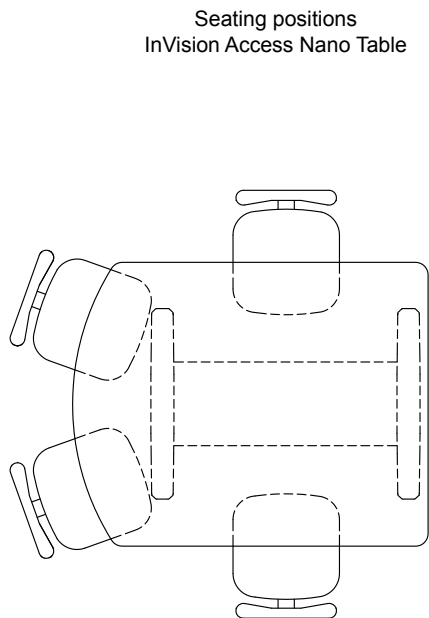

Configured Options

Configured Options from Factory:		
	<i>Factory-Installed</i>	<i>Customer-Installed</i>
Laminate / Edgeband Color	✓	
Metal Color	✓	
Core Style	✓	
Element Display Stand		✓
Cove Power Module(s)		✓
Cove Power Module Color	✓	
Custom Worksurface Cutout	✓	

Accessories:	
<i>Available separately <u>after</u> initial configured purchase (See p.11)</i>	
	<i>Customer-Installed</i>
Element Display Stand - 37130 <i>(Requires worksurface mounting holes and cutout)</i>	✓
Cove Power Module - 99044 <i>(Requires cutout)</i>	✓

Part number breakdown

37129 - CH BK CM C1 1 2 B 0

Parent Number

Custom Worksurface Cutout:

0 = None
1 = Yes (*Contact Spectrum with details*)

Cove Power Module Color:

0 = No Cove Power Modules
B = Black
S = Silver

Number of Cove Power Modules:

0 = None
1 = One Cove Power Module (centered)
2 = Two Cove Power Modules (centered)

Display Stand:

0 = None
1 = with Display Stand

Core Style:

C1 = eLift
C2 = Set and go

Metal Color:

B = Black
CM = Champaign Metallic
D = Dark Gray
S = Silver Sparkle

	Laminate Color:†	Edgeband Color:
Standard Laminates	FM = Fusion Maple	FM = Fusion Maple
	IO = Indigo Organix	BK = Black (non-matching)
	CH = Wild Cherry	CH = Wild Cherry
Premium Laminates* (28-day lead time)	BK = Black	BK = Black
	BL = Bronze Legacy	BL = Bronze Legacy
	CK = Castle Oak	CK = Castle Oak
	CW = Colombian Walnut	CW = Colombian Walnut
	DZ = Desert Zephyr	DZ = Desert Zephyr
	EM = Empire Mahogany	EM = Empire Mahogany
	MO = Morro Zephyr	MO = Morro Zephyr
	MZ = Misted Zephyr	SN = Silver Northsea (non-matching)
	NP = Nepal Teak	NP = Nepal Teak
	NT = Natural Tigris	NT = Natural Tigris
	PM = Pewter Mesh	PM = Pewter Mesh
	SM = Steel Mesh	SM = Steel Mesh
	TZ = Twilight Zephyr	TZ = Twilight Zephyr
WF = White Fiesta	BK = Black (non-matching)	

* Premium laminate colors require an additional 14 days of lead time.

** Factory installed

† Laminate colors come with matching Edgeband color, with these exceptions:

Indigo Organix Laminate comes with Black Edgeband, Misted Zephyr Laminate comes with Silver Northsea Edgeband, and White Fiesta Laminate comes with Black Edgeband.

ORDER CODE C1 = eLift electric adjustable-height

- Electrically adjustable
- 29-42"H [73.7-106.7 cm]

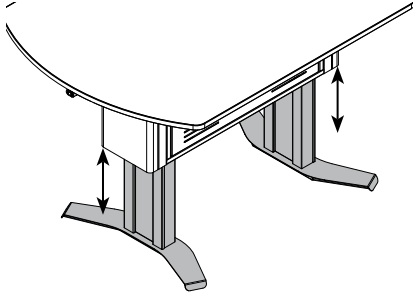

ORDER CODE C2 = Set and go

- Mechanically adjustable in 1" increments
- 29-42"H [73.7-106.7 cm]

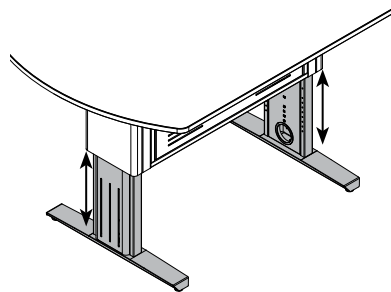

Display Stand

ORDER CODE 0 = None

ORDER CODE 1 = Display Stand

Element Display Stand

- Bolts directly to worksurface
- Integrated cable management routes and hides wires
- Adjustable (VESA-compatible) display mount
- Requires worksurface mounting holes and cutout

Monitor size range:	32"-55" [81.3 cm-139.7 cm] diagonal	
Weight capacity:	100 lb [45.4 kg]	
Vertical adjustment (worksurface-to-center)	• 23.5"H [59.7 cm]	(5 vertical positions in 2" increments)
	• 21.5"H [54.6 cm]	
	• 19.5"H [49.5 cm]	
	• 17.5"H [44.5 cm]	
Tilting	15° range	
Unit weight:	N/A	

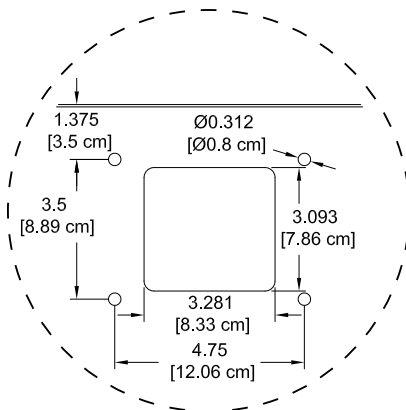

Mounting holes and cutouts needed on flat end of worksurface

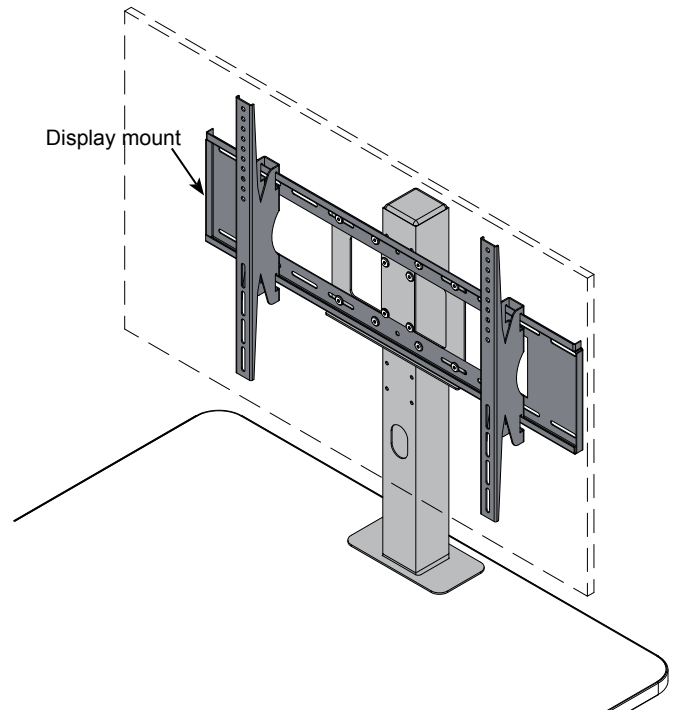

Worksurface option with mounting holes required-specify when ordering

Cove Power Module

- Two power receptacles per module
- Two USB charge ports (not data-compatible)
- Thumbscrew clamps
- Requires worksurface cutout
- ETL listed
- Available in Black or Silver

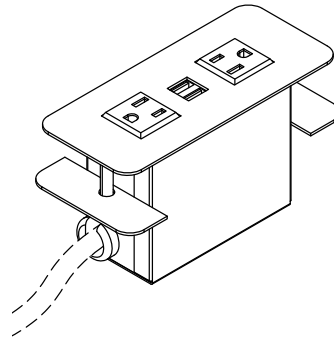

Cutout required:	5.25"W [13.3 cm] x 2"D [5.1 cm] (mounts to surface thicknesses up to 1.5")
Power cord:	9' [274 cm] with 90° flat plug with 45° rotation
Power receptacles:	12A, 120 VAC spill-resistant
USB charging ports:	2.1A (10.5W)
Dimensions:	6"W [15.2 cm] x 2.5"D [6.35 cm] x 3.18"H [8.1 cm]
Unit weight:	2.29 lb [1 kg]

ORDER CODE 0 = None

Standard Cove locations in worksurface

ORDER CODE 1 = One Cove Module

ORDER CODE 2 = Two Cove Modules

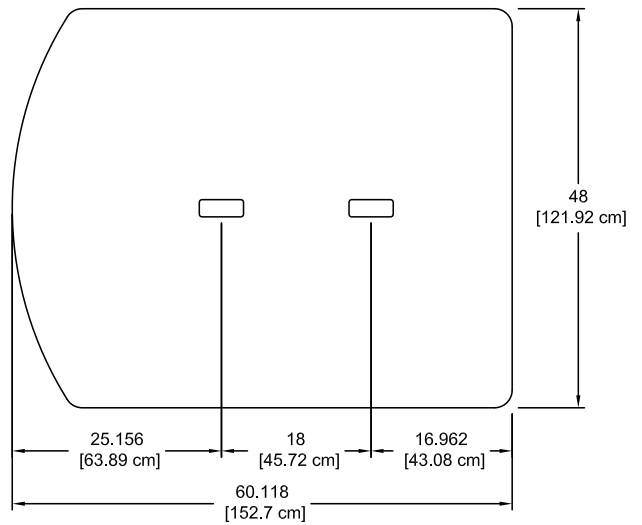
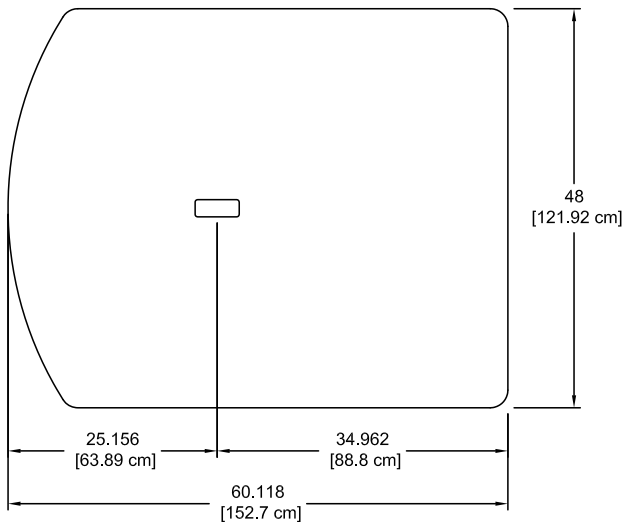

Cove™ Power Module Colors

ORDER CODE 0 = None

ORDER CODE B = Black

ORDER CODE S = Silver



ORDER CODE 0 = None

ORDER CODE 1 = Custom worksurface cutouts

Custom cutouts by Spectrum

- Contact Spectrum to specify cutout size(s) and location(s)
- See recommended cutout areas at left

Spectrum can provide cutouts exactly matching any commercially available data and electrical power outlet, but are only recommended within the maximum cutout areas shown. Cutouts made beyond this shaded area could interfere with the legs, wiring channel, or worksurface braces.

This table has been designed for many of the currently available surface-mount devices on the market.

***When ordering a table with cutouts, specify complete details of the device(s) (brand, model number, cutout size, quantity, etc.) to the Spectrum sales rep when ordering.**

Cutouts in blank worksurfaces can be made by the customer after the table has been assembled, but are only recommended within the cutout areas shown.

InVision Access Nano Table max cutout area in worksurface

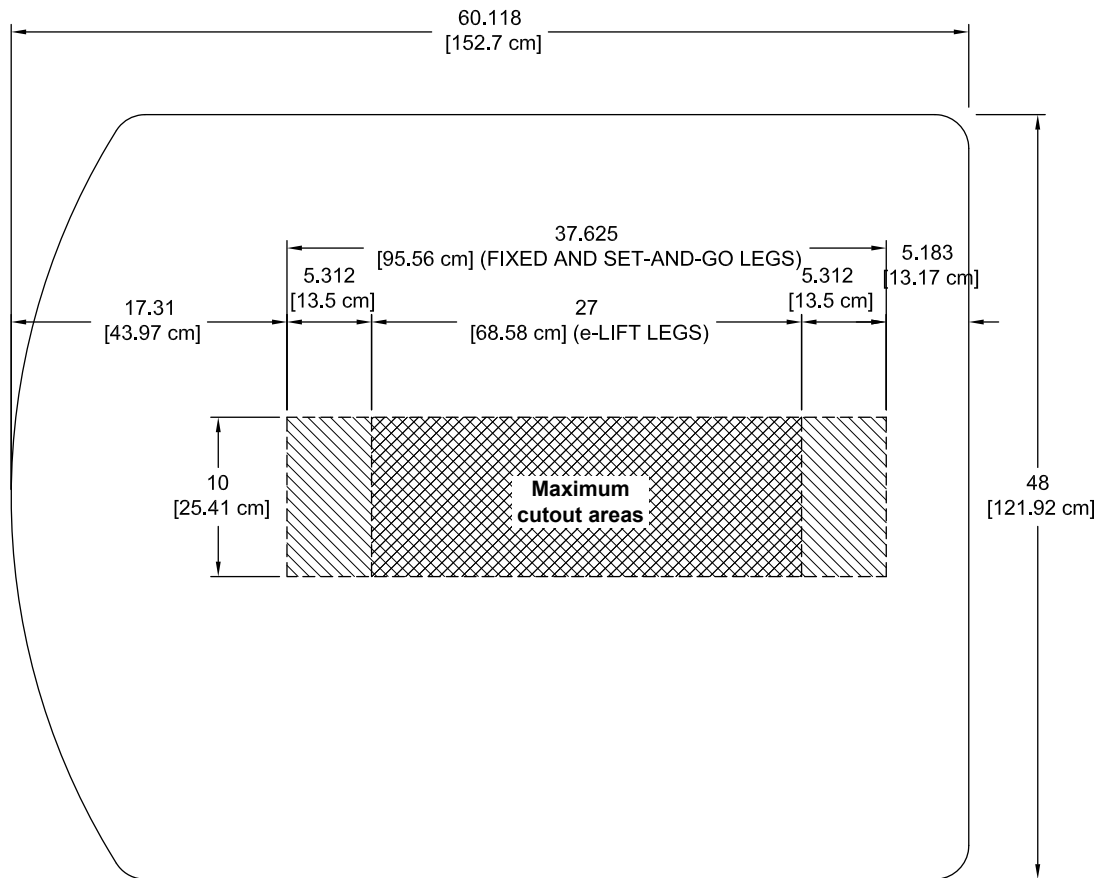

Note: Spectrum Industries, Inc. manufactures furniture that supports a wide variety of power and communication devices from a variety of manufacturers. This table is compatible with many Extron, Crestron, Altinex, AMX, and other devices. Spectrum does not resell these products; please consult your electronic supplier for the equipment that best suits your needs. Size specifications from the manufacturer can be used to verify the fit.



Note: Some controllers and devices require additional space around the cutout for clamping under the worksurface. Please double check your device specifications to ensure adequate space around the cutout.

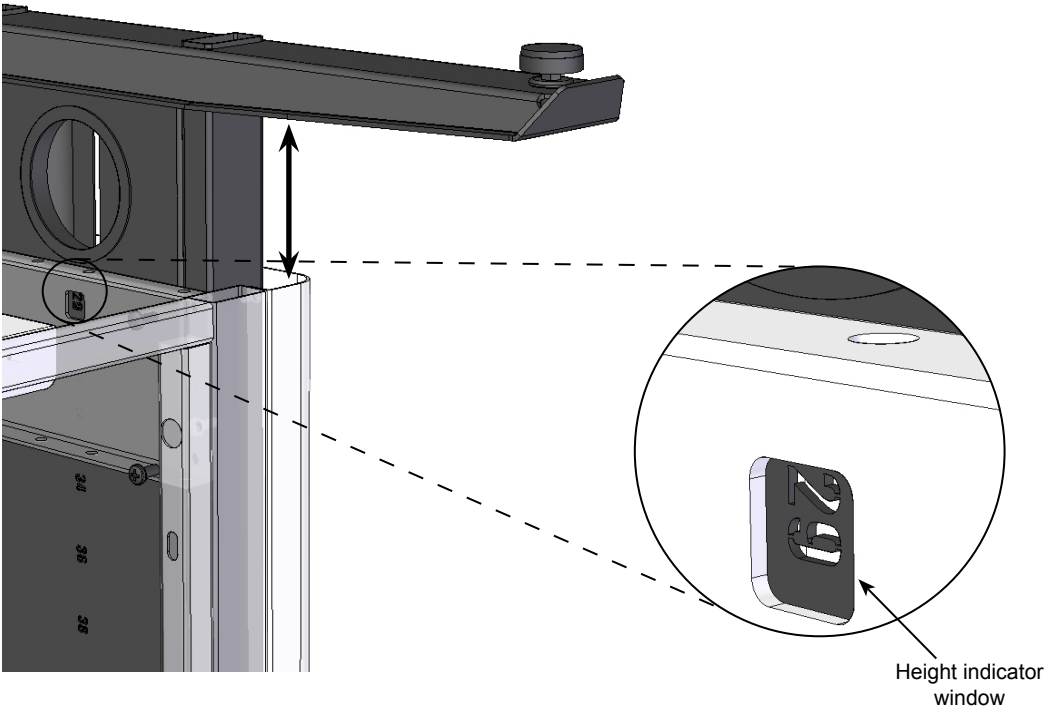

Section view
(Set and go leg shown)

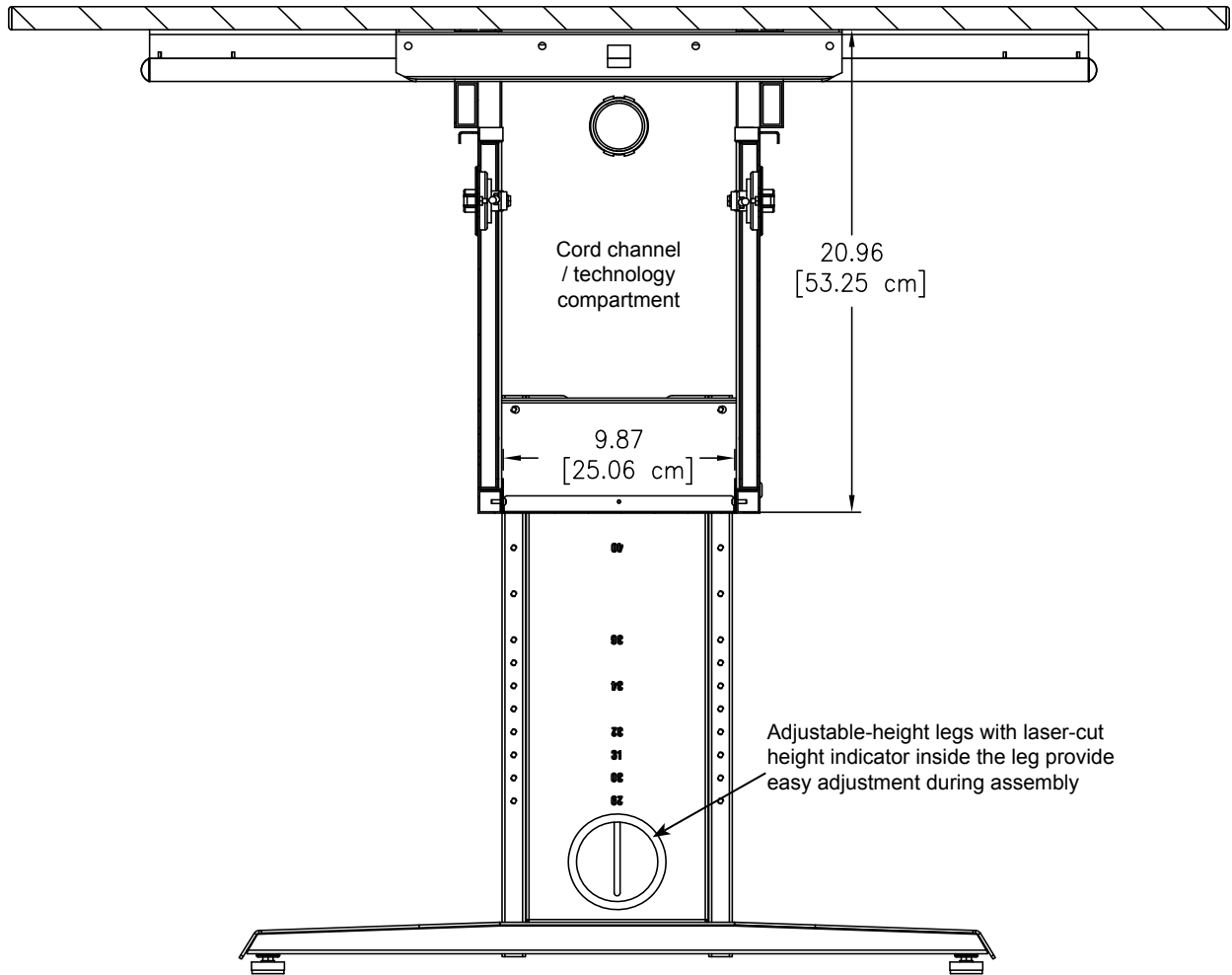

InVision Access Nano Table
with Set and go legs

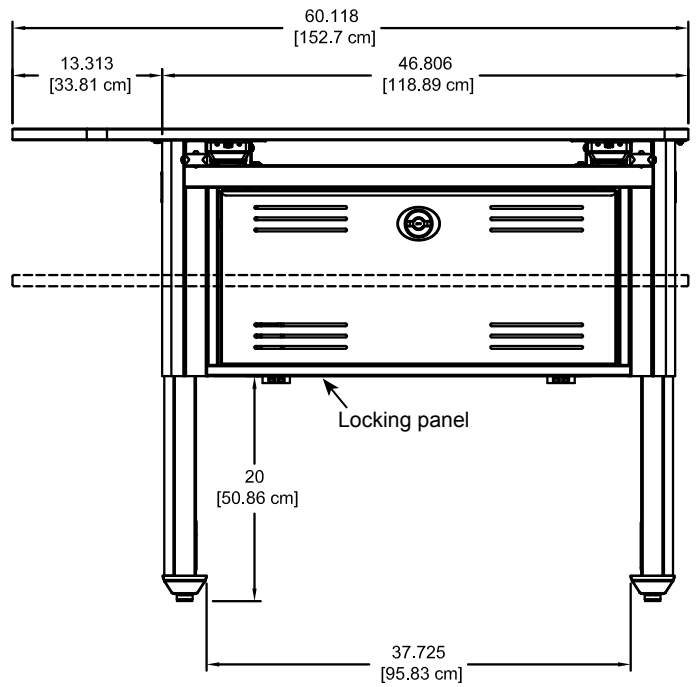
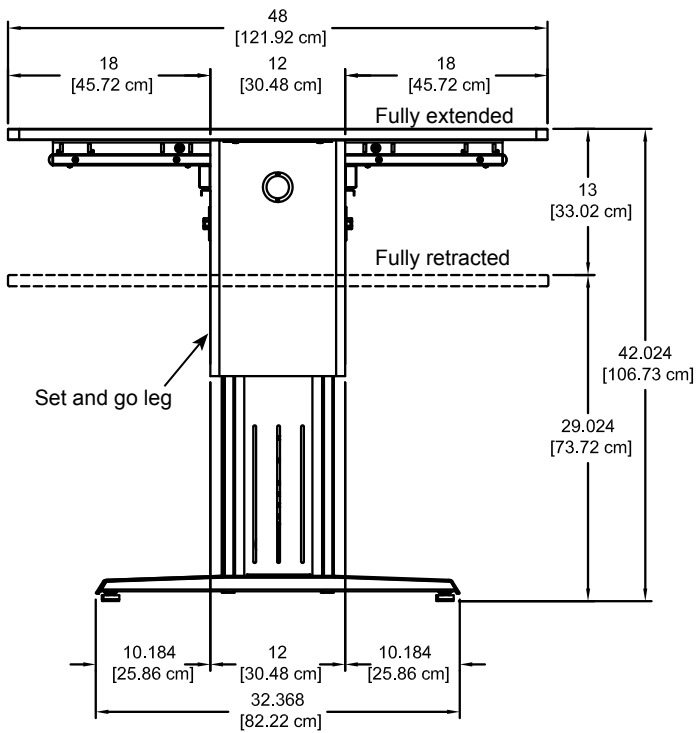
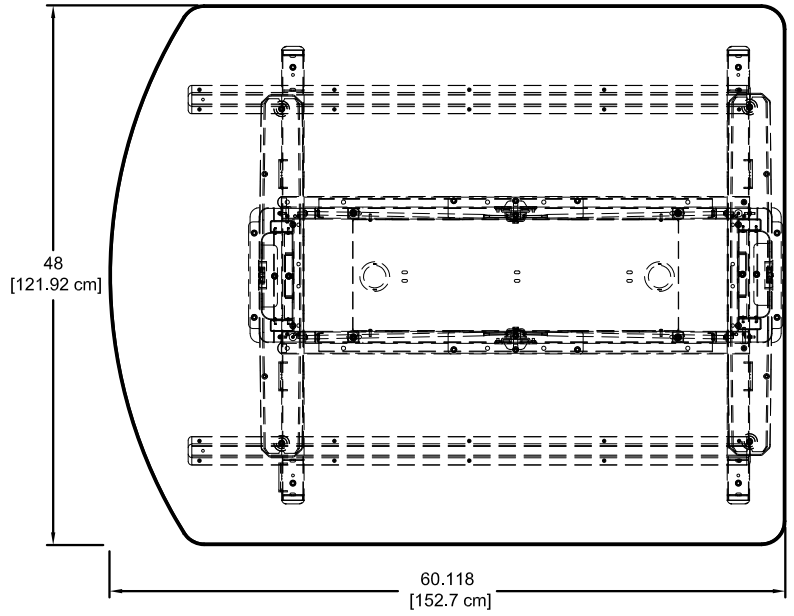
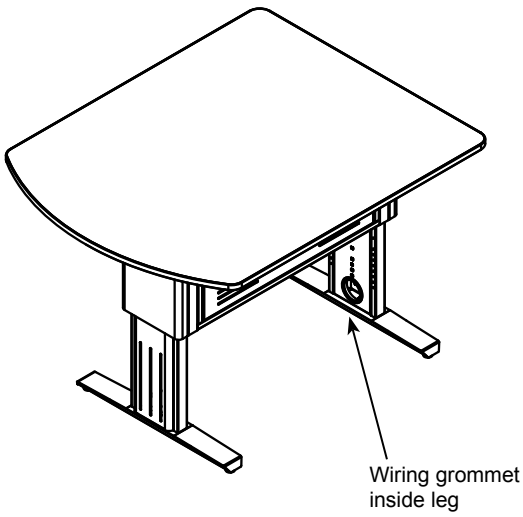

Note: The InVision Access Table does not support optional keyboard trays.

InVision Access Nano Table
with eLift electric legs



Control button

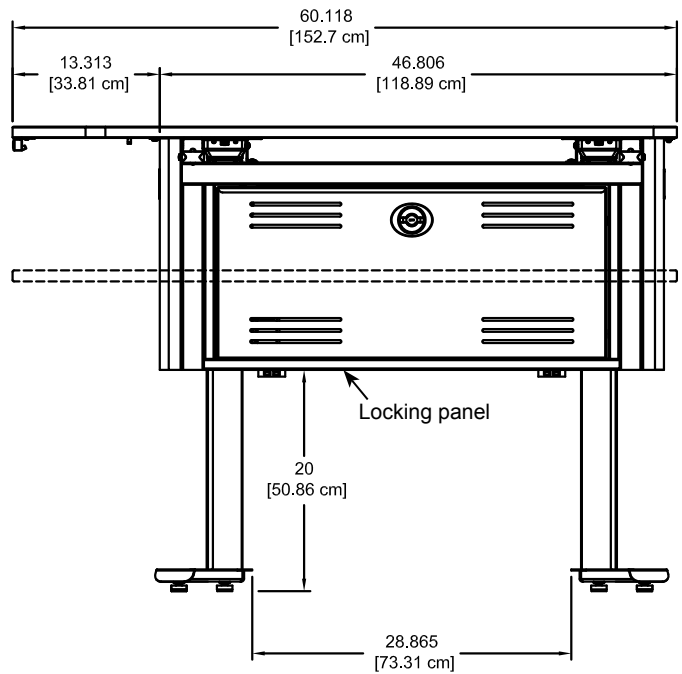
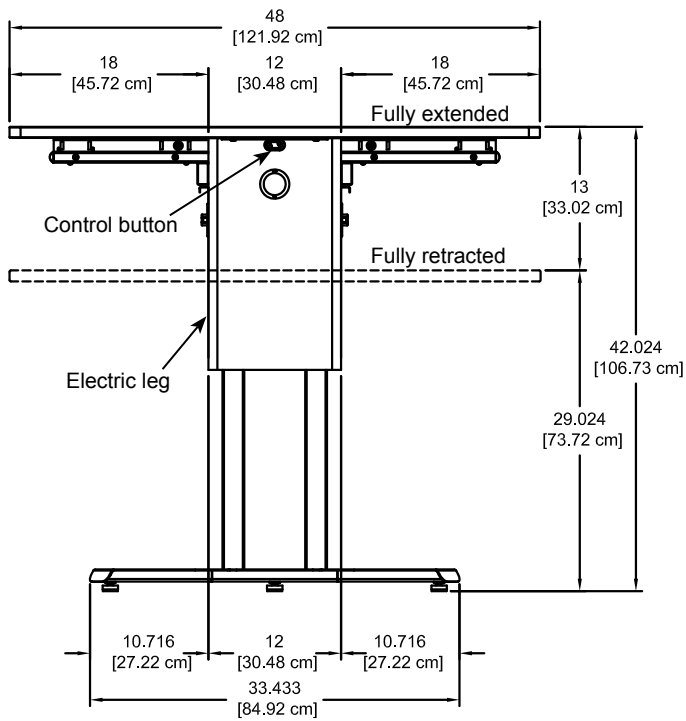
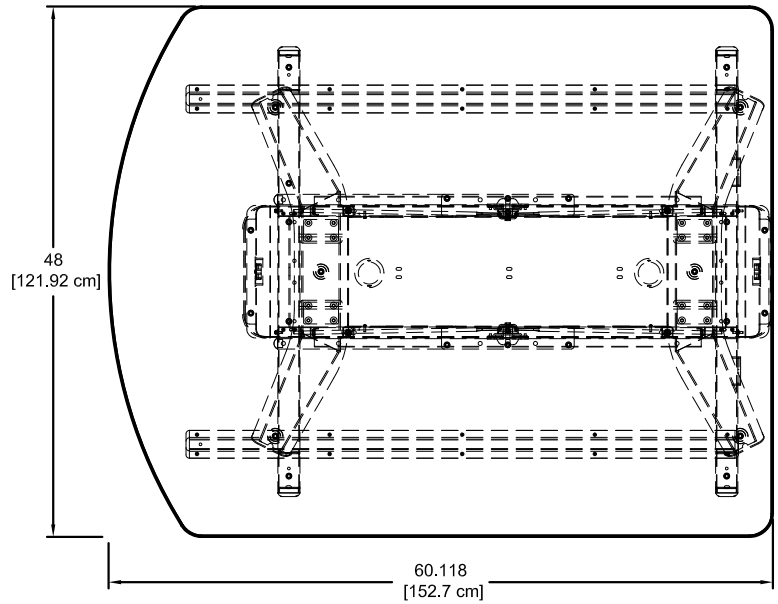
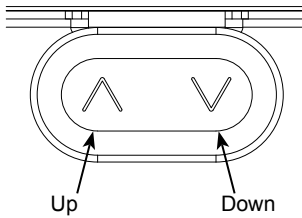

Note: Includes user-mountable control button.

Note: The InVision Access Table does not support optional keyboard trays.

Accessories (Available separately after initial configured purchase.)

Element Display Stand - 37130

- Bolts directly to worksurface
- Integrated cable management routes and hides wires
- Adjustable (VESA-compatible) mount
- Requires worksurface mounting holes and cutout

Monitor size range:	32"-55" [81.3 cm-139.7 cm] diagonal
Weight capacity:	100 lb [45.4 kg]
Vertical adjustment (worksurface-to-center)	<ul style="list-style-type: none"> • 23.5"H [59.7 cm] • 21.5"H [54.6 cm] • 19.5"H [49.5 cm] • 17.5"H [44.5 cm] • 15.5"H [39.4 cm] (5 vertical positions in 2" increments)
Tilting	15° range
Shipping weight:	35 lb [15.9 kg]

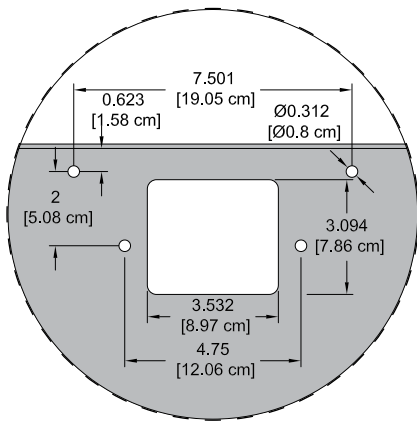
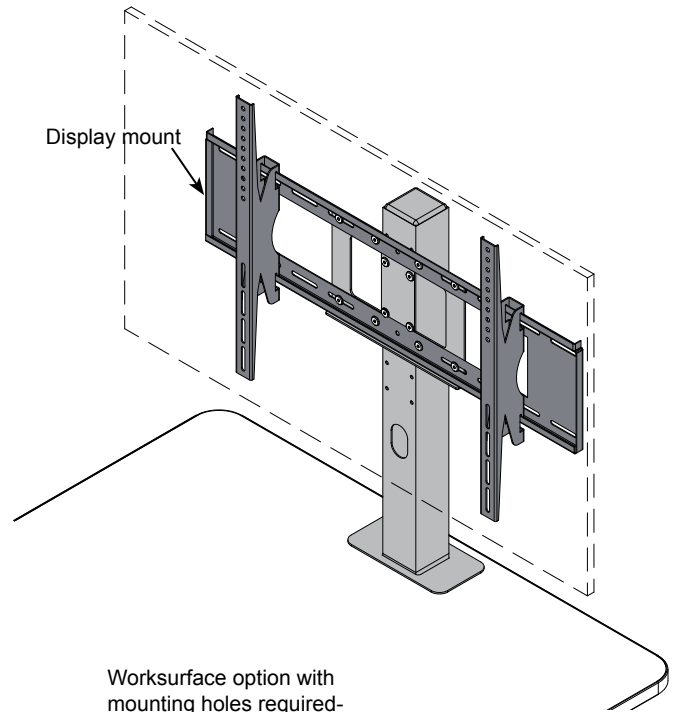

Mounting holes and cutouts needed on flat end of worksurface

Cove Power Module - 99044

- Two power receptacles per module
- Two USB charge ports (not data-compatible)
- Thumbscrew clamps
- Requires worksurface cutout
- ETL listed
- Available in Black or Silver

Cutout required:	5.25"W [13.3 cm] x 2"D [5.1 cm] (mounts to surface thicknesses up to 1.5")
Power cord:	9' [274 cm] with 90° flat plug with 45° rotation
Power receptacles:	12A, 120 VAC spill-resistant
USB charging ports:	2.1A (10.5W)
Dimensions:	6"W [15.2 cm] x 2.5"D [6.35 cm] x 3.18"H [8.1 cm]
Unit weight:	2.29 lb [1 kg]

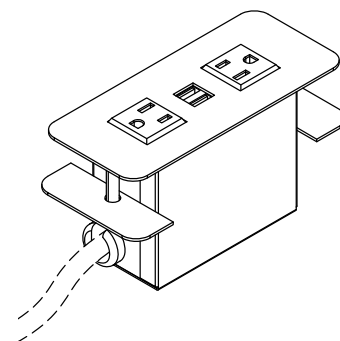

Warranty

WE WILL MAKE IT RIGHT FOR YOU!

Spectrum is committed to provide complete customer satisfaction. Each of our products is manufactured from the best materials available and each product is stringently monitored throughout the production process through our P.A.C.E. program (Product Assurance to meet Customer Expectations).

We expressly warrant that Spectrum products will be of good quality and workmanship and free from defect for the period set out in the warranty table below from the date of delivery. This warranty shall not apply to defects or damage resulting from misuse, abuse, neglect, improper care, modification or repair not authorized by Spectrum, or any other cause outside the control of Spectrum. Spectrum will, at its sole option, either repair or replace the defective product.

This warranty is exclusive; no other warranty, written or oral, is expressed or implied. This warranty is given by Spectrum to Buyer and to no other person or legal entity. No Spectrum dealer, distributor, agent or employee is authorized to make any modification or addition to this warranty.

NOTWITHSTANDING ANYTHING TO THE CONTRARY, SPECTRUM WILL NOT UNDER ANY CIRCUMSTANCES BE LIABLE FOR INDIRECT OR LIQUIDATED DAMAGES, INCLUDING CONSEQUENTIAL, INCIDENTAL AND SPECIAL DAMAGES. IN NO EVENT SHALL SPECTRUM'S LIABILITY, WHETHER UNDER CONTRACT OR WARRANTY, IN TORT OR OTHERWISE, EXCEED THE PURCHASE PRICE RECEIVED BY SPECTRUM FOR THE PRODUCT AT ISSUE AND "RECALL ACTION" EXPENSES. SPECTRUM SHALL NOT BE SUBJECT TO ANY OTHER OBLIGATIONS OR LIABILITIES, WHETHER ARISING OUT OF BREACH OF CONTRACT, WARRANTY, TORT (INCLUDING NEGLIGENCE AND STRICT LIABILITY) OR OTHER THEORIES OF LAW, WITH RESPECT TO PRODUCTS SOLD OR SERVICES RENDERED BY SPECTRUM, OR ANY UNDERTAKINGS, ACTS OR OMISSIONS RELATING THERETO.

Our Customer Service Department is ready to provide immediate attention to any questions, comments or concerns. They are available to answer your calls Monday through Friday from 7 am to 5 pm CST. In addition your product comments or concerns are welcome via e-mail at: spectrum@spectrumfurniture.com.

Warranty Table

effective 1/1/2015

Item	Warranty Period
Adjustable Crank / Electric Desk Legs	• 1 Year
Flat Panel Desk Gas Cylinders	
Chairs <ul style="list-style-type: none"> • Adjustable Height Chair Parts – including frames, gas cylinders, wood and plastic parts, control handles, casters • Adjustable Height Chair Upholstery • In-Stock Upholstery • Graded-In Fabrics and Customer Owned Material 	<ul style="list-style-type: none"> • 7 Years • 2 Years • 2 Years • No Warranty
Height Adjustable Columns and Lifts	• 1 Year
General Use Casters	
Electrical (including timers and LINAK actuators)	• 2 Years
Keyboard / Mouse Trays	• 1 Year
Flat Panel Monitor Arms <ul style="list-style-type: none"> • Flat Panel Monitor Arm – General Parts • Flat Panel Monitor Arm – Gas Cylinders 	<ul style="list-style-type: none"> • 5 Years • 2 Years
Desks and Lecterns <ul style="list-style-type: none"> • Computer Desk Chassis • Cart Chassis • Lectern Chassis 	• 10 Years



INDOOR ADVANTAGE GOLD
FURNITURE

