

Assembly Instructions

⚠ Important ⚠

Before you begin, read and comply with all safety and operating instructions, and ensure all parts and correct quantities are included.

Any parts damaged during shipment must be reported within 5 days of receipt. To report information regarding missing parts or damage, to purchase parts or accessories, or if you have any questions, please contact us.

www.spectrumfurniture.com
800-235-1262, 715-723-6750

Thank you for purchasing Spectrum products!

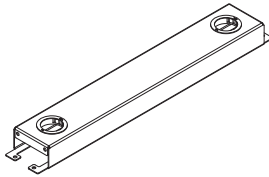
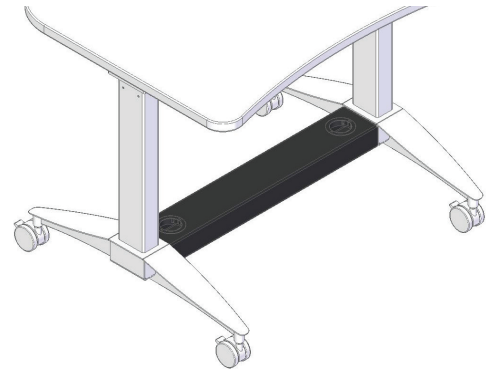

(1) 0138388
Footrest

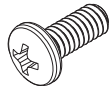

(4) 026064
1/4-20 x 5/8" PHMS

Footrest for Pivot Workstation™ 37327

Installation

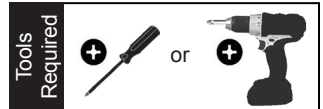

1. Carefully flip the workstation upside-down onto a non-abrasive surface. This may require 2-3 people.
2. Remove the (2) inside sets of pre-installed M6 screws from the bottom of each leg. **Figure 1**.
3. Set the footrest onto the legs and align the mounting holes.
4. Re-install the M6 screws.
5. Install (4) 1/4-20 x 5/8" PHM screws (inside footrest).
6. Tighten all screws securely.

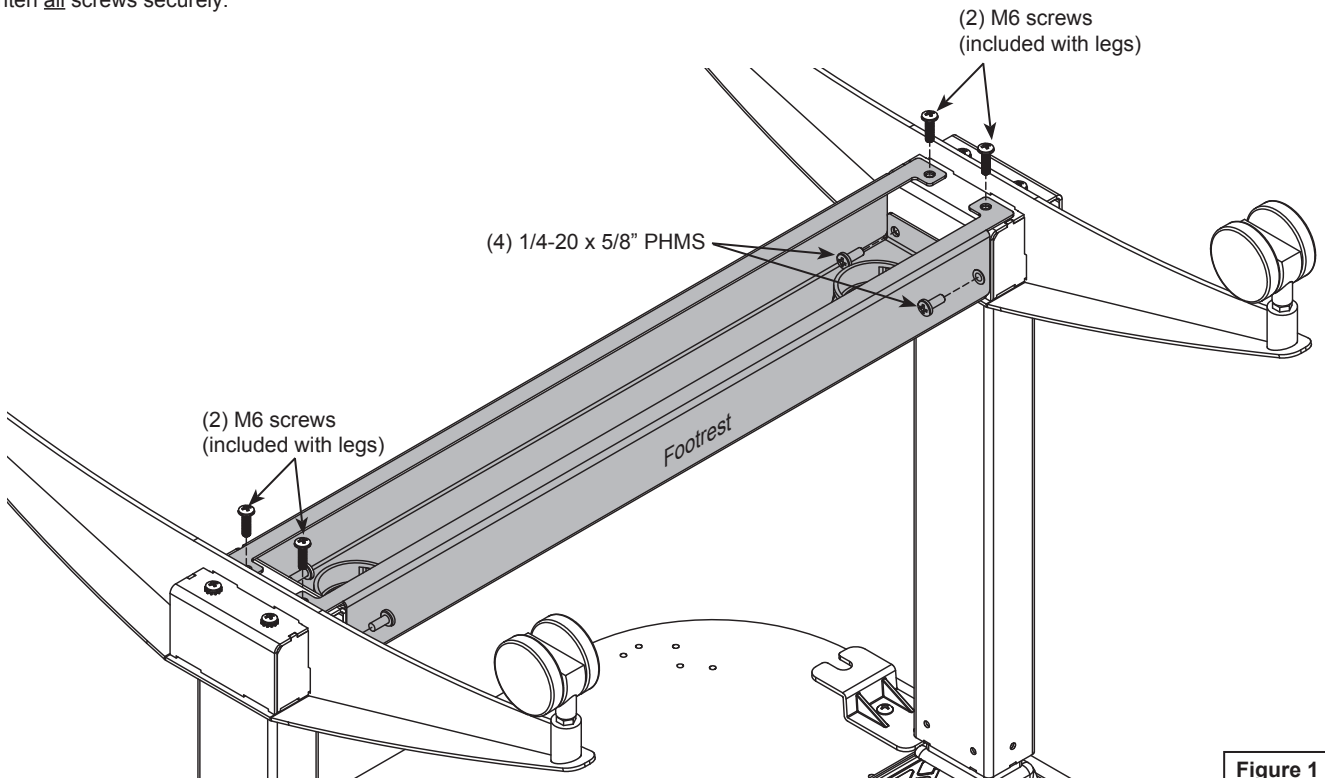

Figure 1