

# Assembly Instructions

## ⚠ Important ⚠

Before you begin, read and comply with all safety and operating instructions, and ensure all parts and correct quantities are included.

Any parts damaged during shipment must be reported within 5 days of receipt. To report information regarding missing parts or damage, to purchase parts or accessories, or if you have any questions, please contact us.

[www.spectrumfurniture.com](http://www.spectrumfurniture.com)  
800-235-1262, 715-723-6750

Thank you for purchasing Spectrum products!

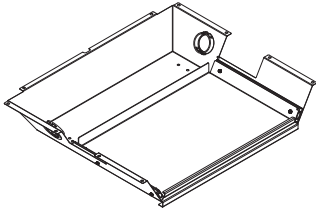

(1) Pull-out keyboard tray assembly with (2) 059984 2" Grommets installed

 (10) 0101382  
#14 x 7/8" PHSM

 (4) 052605  
1/4-20 x 15mm  
JC bolt

 (4) 041943  
1/4-20 locknut

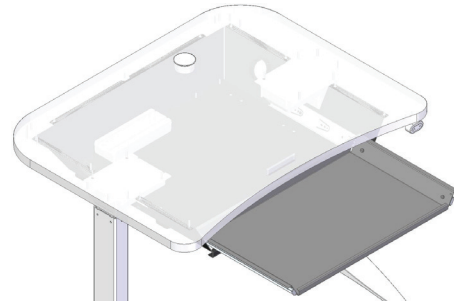

## Pull-out keyboard tray for Pivot Workstation™ 37329



## Installation

- Carefully flip the workstation upside-down onto a non-abrasive surface. This may require 2-3 people.
- Relocate the (2) existing worksurface cord wraps to the bottom of the assembly as shown with 1/4-20 x 15mm JC bolts and locknuts. **Figure 1.**
- Attach the keyboard tray assembly to the worksurface with (10) #14 x 7/8" PHSM screws.
- Route the power cord through the side grommet.

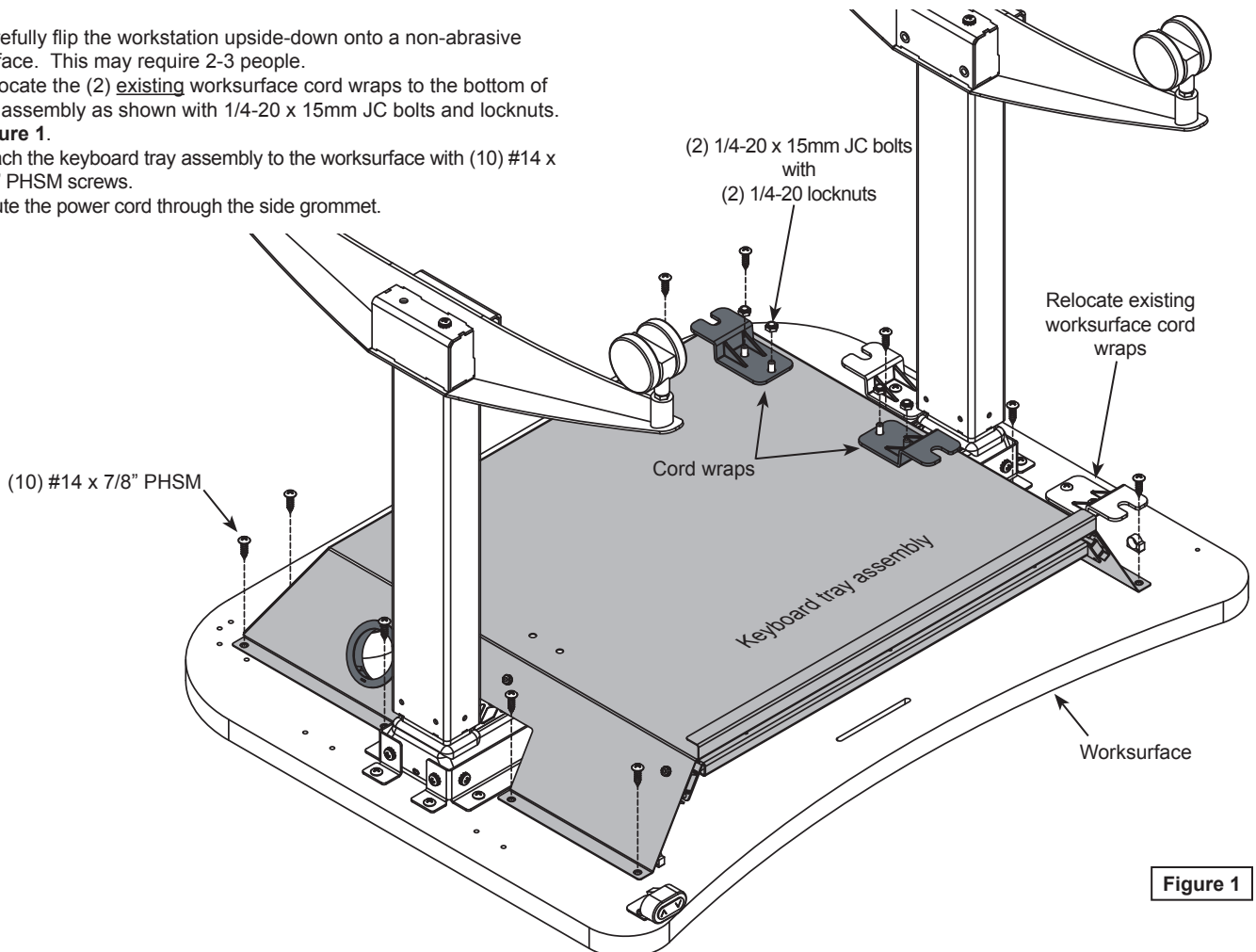

Figure 1