

Assembly Instructions

⚠ Important ⚠

Before you begin, read and comply with all safety and operating instructions, and ensure all parts and correct quantities are included.

Any parts damaged during shipment must be reported within 5 days of receipt. To report information regarding missing parts or damage, to purchase parts or accessories, or if you have any questions, please contact us.

www.spectrumfurniture.com
800-235-1262, 715-723-6750

Thank you for purchasing Spectrum products!

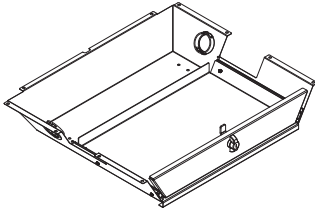

(1) Locking pull-out
drawer assembly
with (2) 059984 2"
Grommets installed



(10) 0101382
#14 x 7/8" PHSM



(4) 052605
1/4-20 x 15mm
JC bolt



(4) 041943
1/4-20 locknut

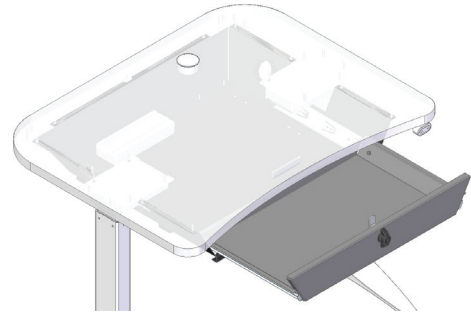

Locking pull-out drawer for Pivot Workstation™ 37330



Installation

- Carefully flip the workstation upside-down onto a non-abrasive surface. This may require 2-3 people.
- Relocate the (2) existing worksurface cord wraps to the bottom of the assembly as shown with 1/4-20 x 15mm JC bolts and locknuts. **Figure 1.**
- Attach the locking drawer assembly to the worksurface with (10) #14 x 7/8" PHSM screws.
- Route the power cord through the side grommet.

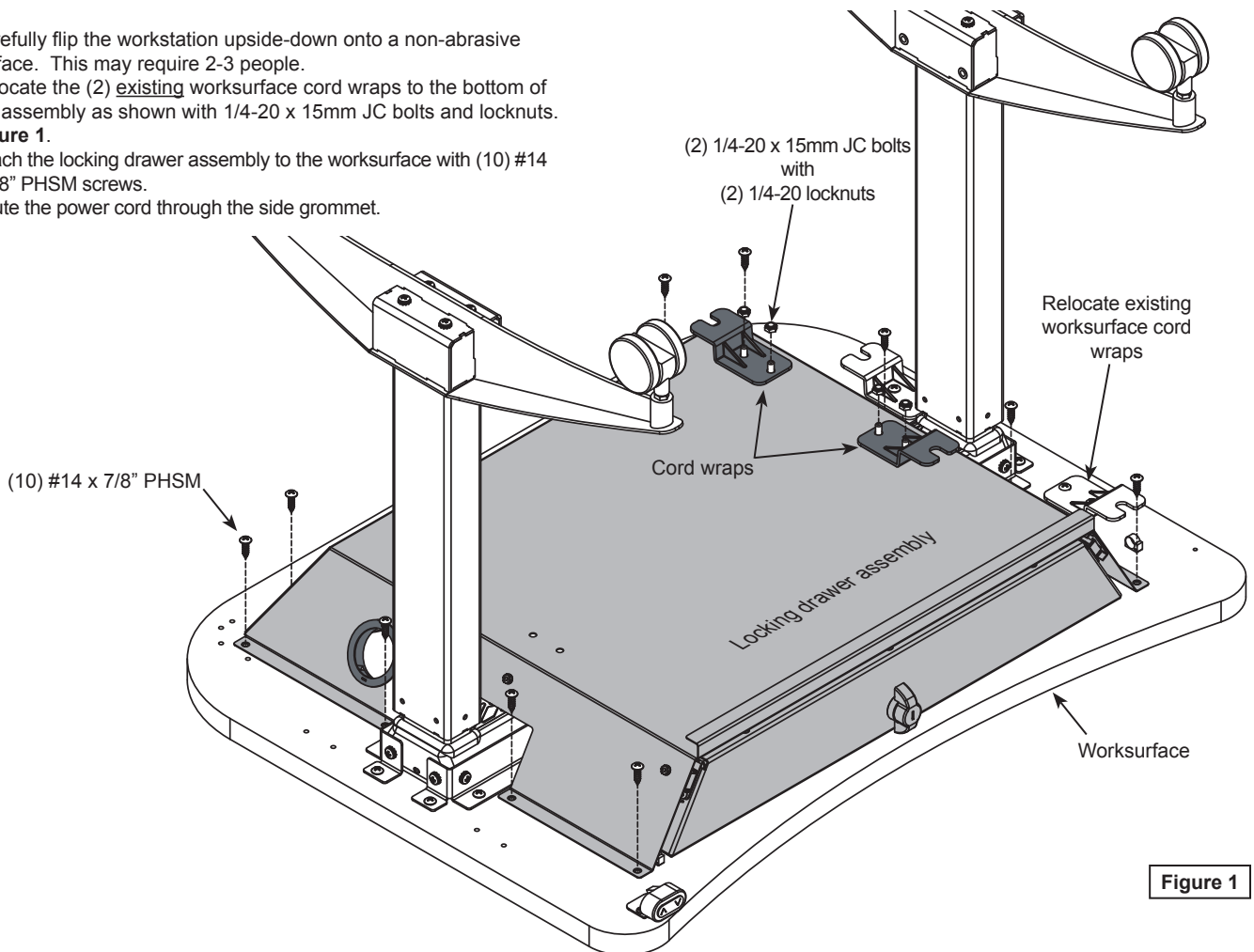

Figure 1