

Technical Specifications

w/ Power switch (no modules) - 55105GA

w/ eLogix timer (no modules) - 55105GK

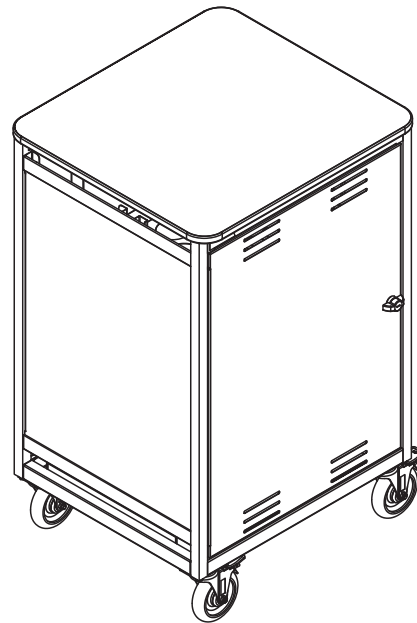
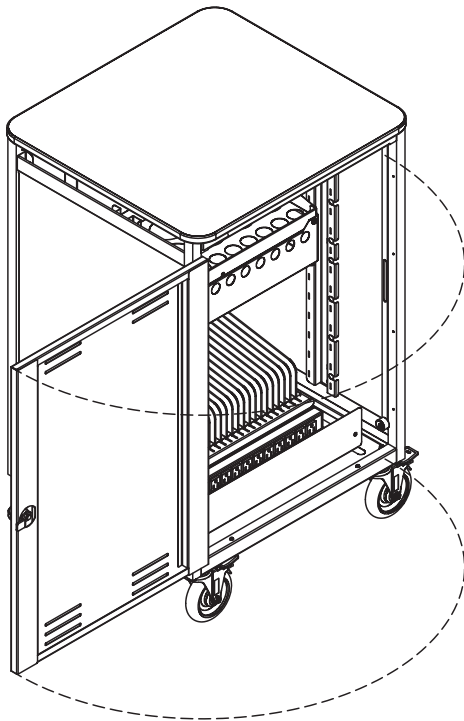

The economical Pathway Cart stores, charges, and transports educational robotics and mobile devices used in makerspace environments. Interchangeable optional device modules protect and charge mobile / robotic devices and can be easily replaced to accommodate future technology changes. Two electrical options are available. The cart's compact footprint maximizes classroom space, and superior wheels provide easy mobility between classrooms. Heavy-gauge steel chassis and locking door increases security for all your devices.





Features and Benefits

- Stores, charges, and transports up to 12 large, and 12 small robotic devices (like Sphero®, Dash & Dot, Ozbot and other robotics), and 12 tablets / Chromebooks (most up to 15.6" diagonal)
 - 1.25"W x 15.4"D x 11.4"H storage bay (Mobile Device Module)
 - Easy front-loading design simplifies deployment and storage
 - Small cart footprint (26"W x 24"D) saves valuable space
 - Durable ABS plastic dividers protect notebooks from scratching (dividers are removable to provide storage space for thicker devices)
 - Adjustable-height, removable device modules can be replaced for future technology changes
 - Door features a single-point steel lock for security
-
- (125V~/12A, 60Hz) universal power unit with 12 rotated and staggered outlets work with most AC adapters (Mobile Device Module)
 - External power switch provides easy-access for safe power connection / disconnection
 - External LED illumination on timers indicate charge status
 - Large wiring tray provides convenient power adapter and wiring storage
 - Ventilated door and side panels keep devices and chargers cool, preventing overheating, and extending device life

- Replaceable, IEC (quick-release) 8' nominal 14 AWG, 3-wire power cord and external recessed cord wrap brackets provide easy power access
 - Four inboard 5" balloon wheel plate casters (two locking, two non-locking) with metal construction and non-marring rubber provide easy rolling, and quiet transport (rated for 300 lb each)
-
- Cart ships fully-assembled for quick, simple integration and deployment
 - Durable powder coated steel chassis provides a long-lasting finish
 - Optional device module compatible
 - ETL recognized (certified to UL 60950-1) in the US and Canada for the cart and electrical system
 - Warranted to be free of all defects in materials and workmanship for 10 years, electrical system 2 years
 - Designed and assembled in Chippewa Falls, WI, USA

Note: Device modules are available separately

Color Options

Metal:	Laminate top & edgeband:
	
Light Blue	Steel Mesh
	
White	

Construction

- 20-gauge door, side panels, and base
- All metal components are finished with a scratch-resistant powder coat epoxy
- ABS plastic dividers
- Top panel is constructed from 3/4" NAF (No Added Formaldehyde) composite board
- Top panel edges are covered with 3mm vinyl edgeband
- This cart is factory-assembled, packaged, and shipped on its own skid. Modules may require some customer assembly.

Specifications

Cart capacity	See p.6 for module combinations	
Charging options	(See p.3 for specs)	
5" Balloon Wheels	Weight capacity 300 lb [136.2 kg] each (two locking, two non-locking)	
Certifications / Compliance	<ul style="list-style-type: none"> • ETL recognized • SCS Indoor Advantage Certified 	<ul style="list-style-type: none"> • Meets or exceeds applicable ANSI-BIFMA test standards
Unit weight (nominal)	85 lb [38.6 kg]	
Shipping weight (nominal)	117 lb [53 kg]	

Specifications subject to change without notice

Mobile Device Module storage bays

Note: Do not place items weighing more than 50 lb [22.7 kg] on the top surface. Please remove or secure items before moving cart.

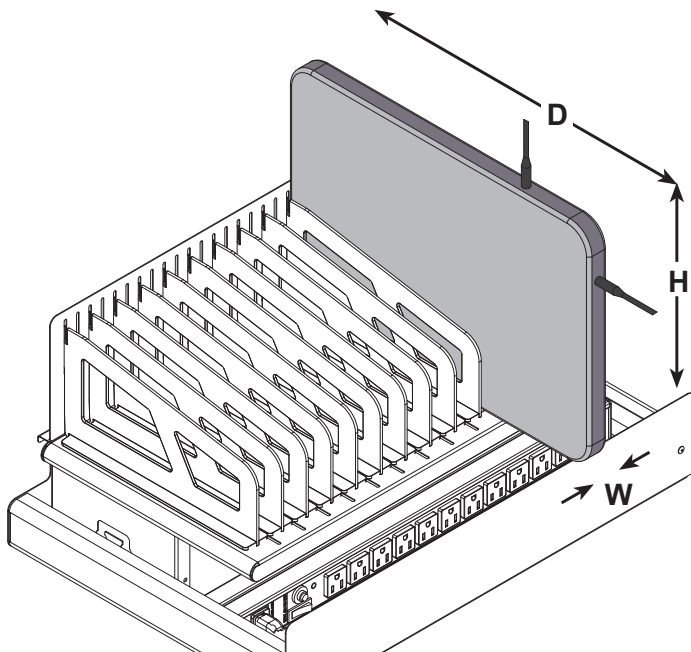

Devices must be placed in the bays with the charge plug on one of the two exposed edges shown.

5" Balloon Wheel

Note: (2) locking, and (2) non-locking balloon wheels are included on each unit.

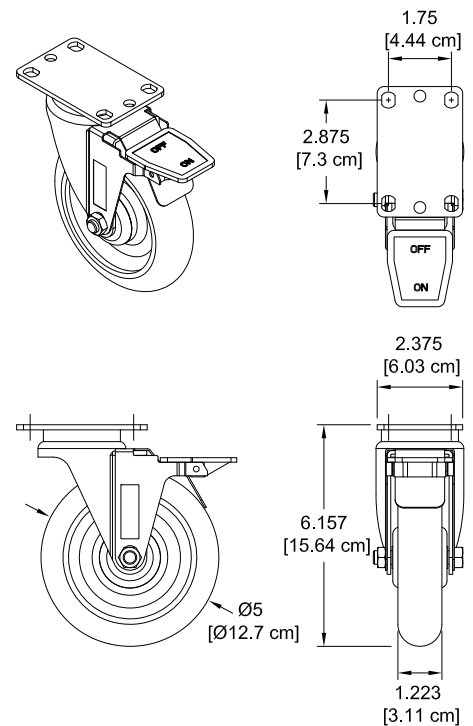

Pathway Cart™ Electrical comparison		
Power switch	eLogix™ timer	
✓		Top auxiliary outlet
✓	✓	Bottom auxiliary outlet
✓	✓	ON/OFF switch
	✓	Current-sensing technology
✓		Continuous power (4 bank)
	✓	Cycled power (2 bank)
	✓	LED lights indicate charging status
✓	✓	ETL certified to 60950-1

⚠

Note: The customer should be aware of the amp draw of the devices used with this cart-especially when maxing out the storage and charging capacity. Exceeding 15 amps will trip the circuit breaker. Please consult the owners manual of your specific device for power consumption information.

**Total maximum wattage will be effected by actual charge adapter wattage and number of charge adapters per cart.*

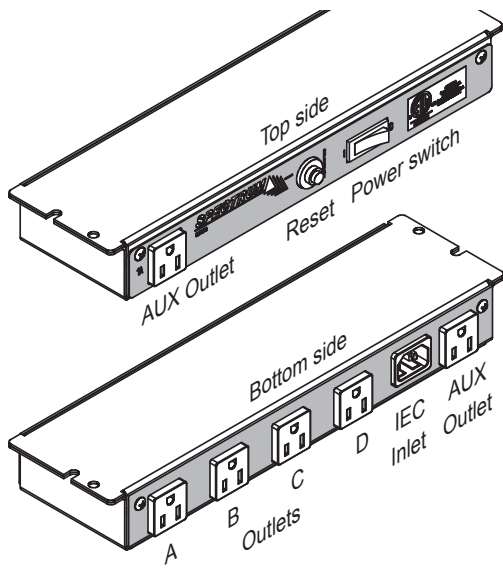

Power Switch (R)

The Power Switch provides continuous power to all devices. Most common electrical option and used with lower amp-draw devices.

- Four continuous power-unit dedicated outlets (labeled A, B, C, D)
- Two auxiliary outlets (1 top, 1 bottom)
- ETL recognized (certified to 60950-1)

Input:	125V~/12A, 60Hz
Breaker:	15A, 250 VAC
Outlets:	4 timed (A, B, C, D) up to 10A
Auxiliary outlets:	1A each (controlled by main power switch)
Power Cord:	IEC quick-release (replaceable) 8' nominal, 14 AWG, 3-wire
Power switch:	15A

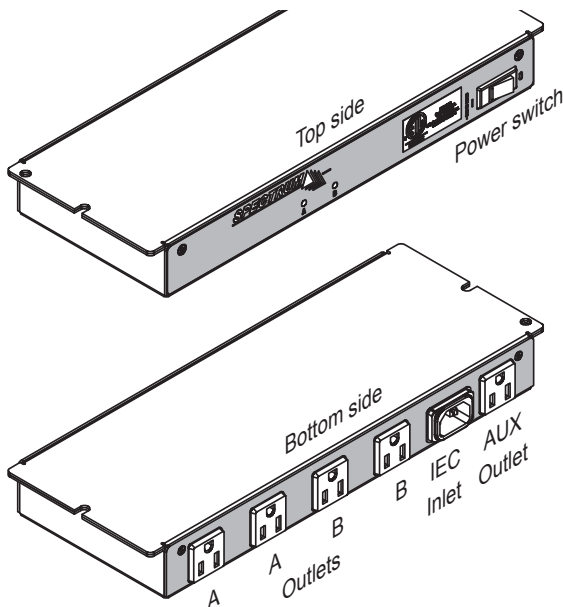

eLogix™ Timer (T)

The eLogix™ timer charges half of the devices for 15 minutes, then charges the second half of the devices for another 15 minutes. This cycling occurs automatically and is not adjustable.

- Two timed outlets (labeled A, B) (up to 10A power output)
- Two green LED lights indicate charging activity status of each power unit
- One auxiliary outlet (bottom)
- ETL recognized (certified to 60950-1)

Input:	125V~/12A, 60Hz
Breaker:	15A, 250 VAC
Cycling interval:	15 minutes
Cycling outlets:	4 timed (A, B) up to 10A
Auxiliary outlet:	1A (controlled by main power switch)
Power Cord:	IEC quick-release (replaceable) 8' nominal, 14 AWG, 3-wire
Power switch:	15A

Pathway Cart

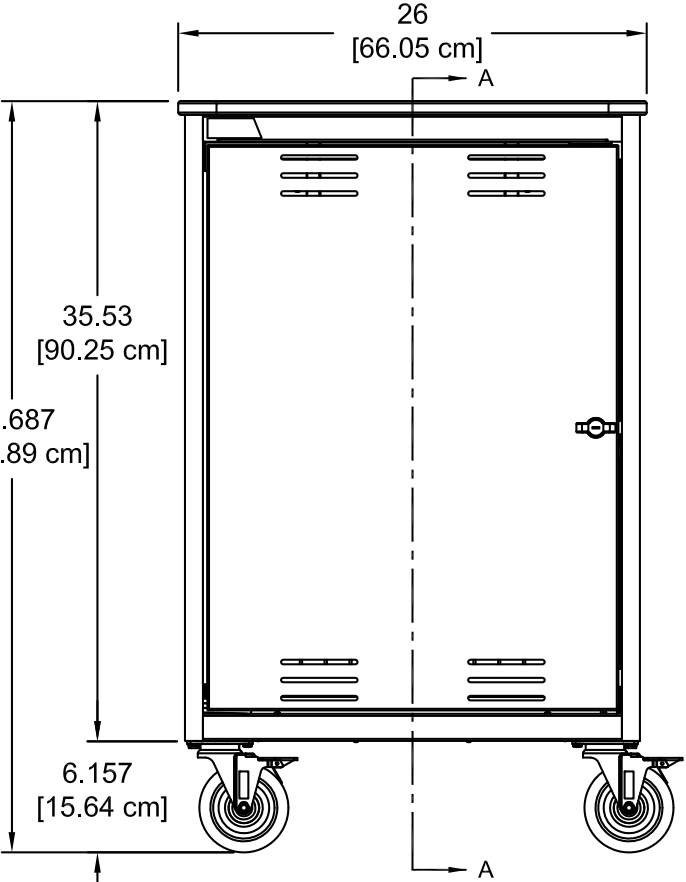
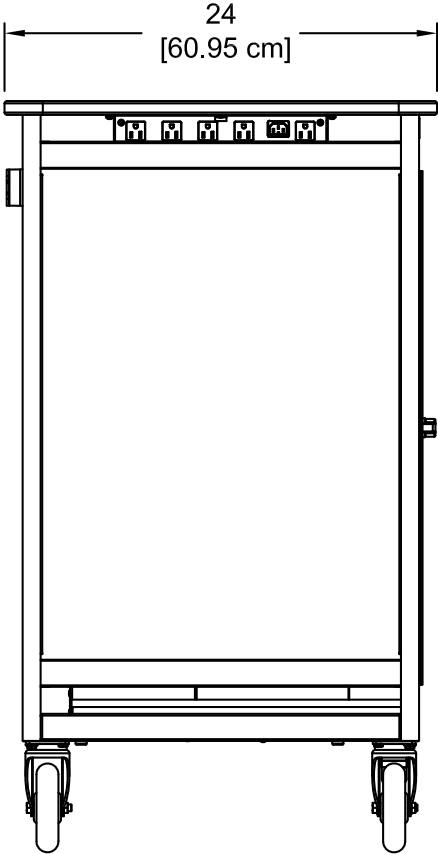
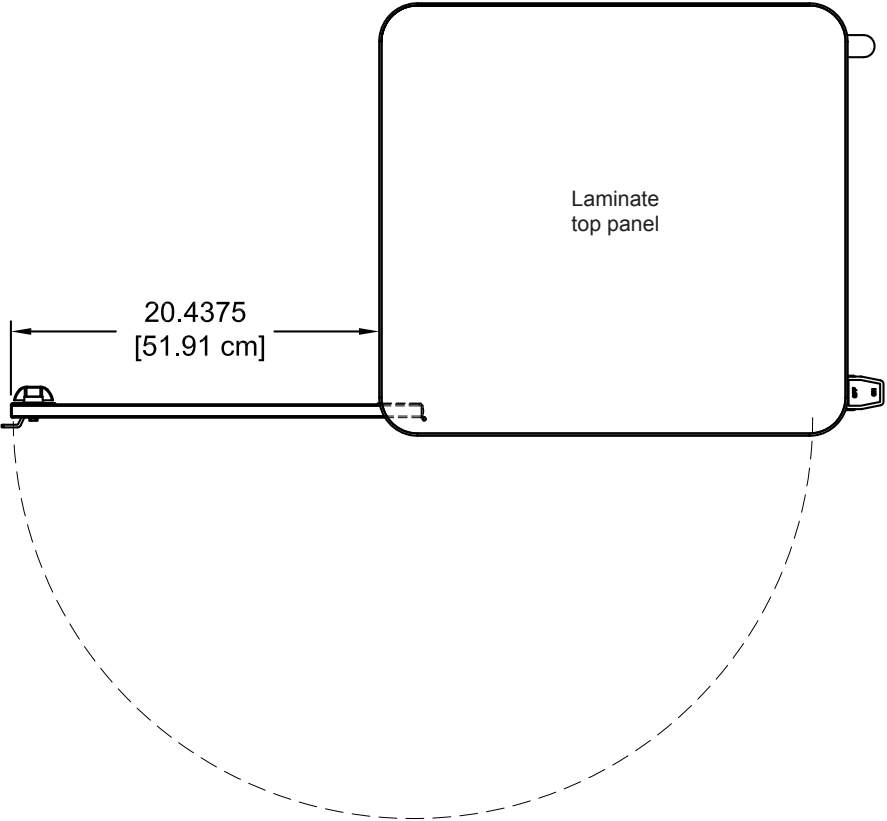
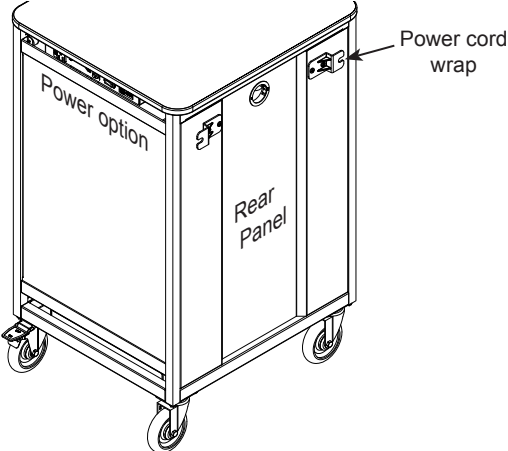
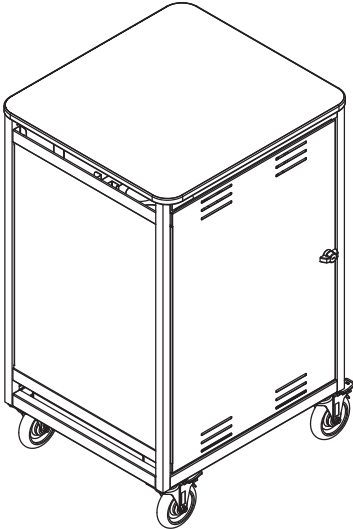

Pathway
Section view A-A

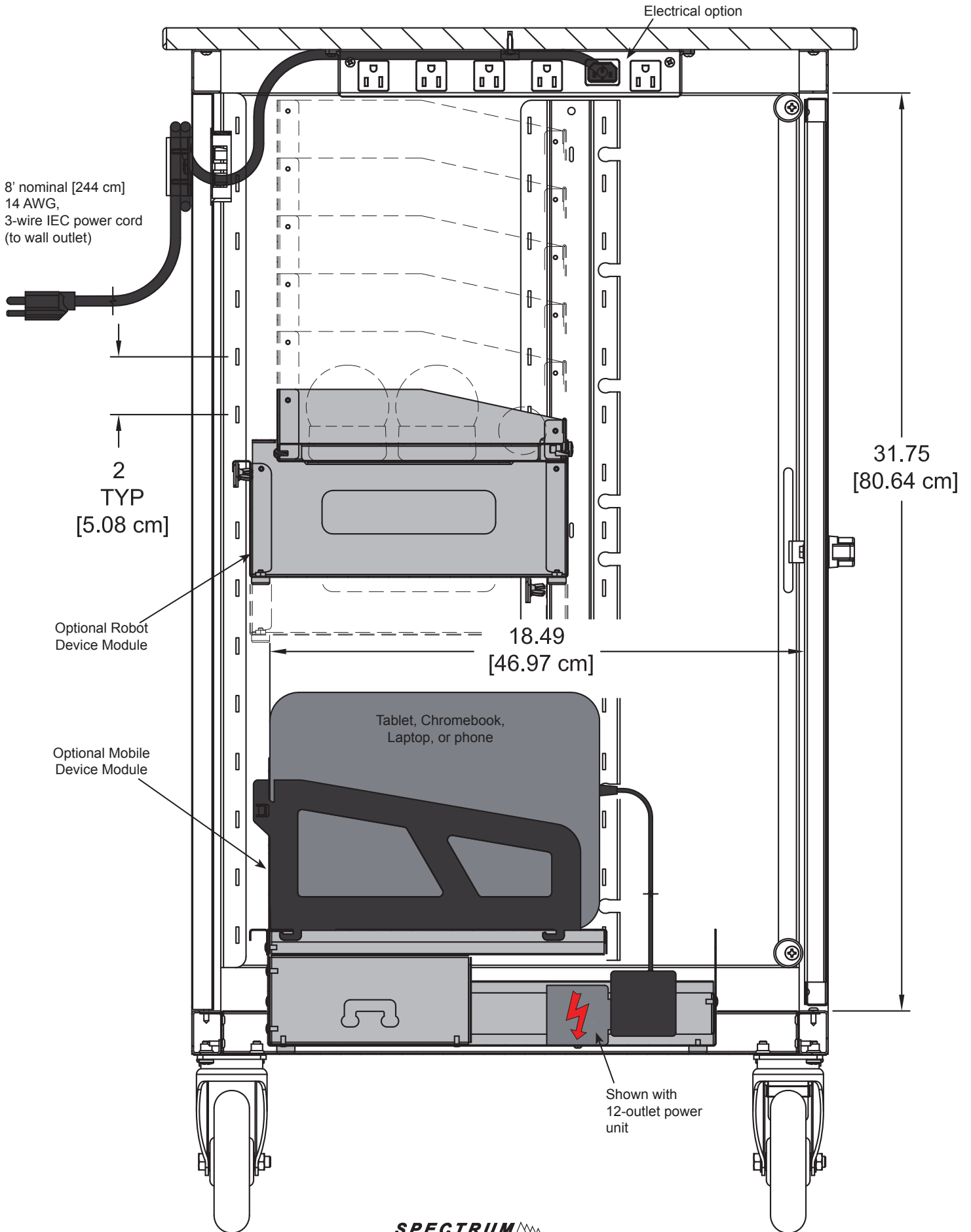

Pathway Cart
 Available module combinations
 (shown without door)

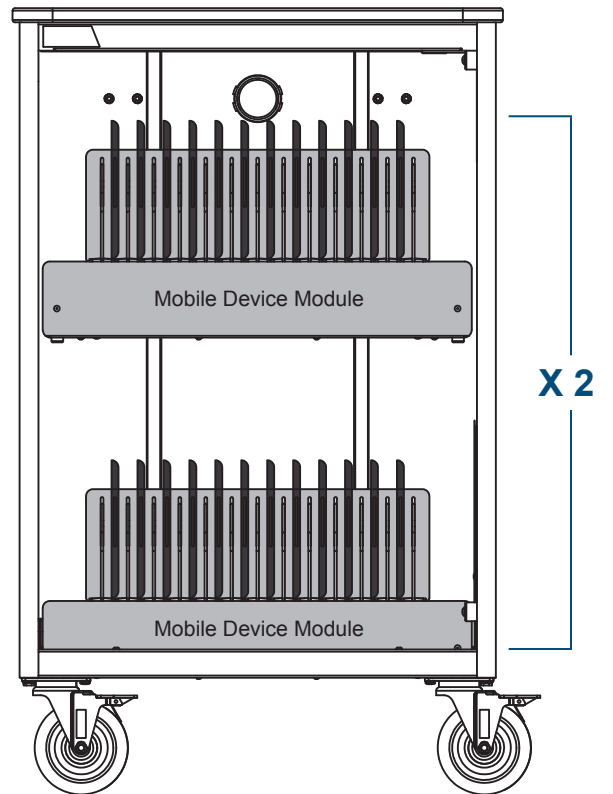
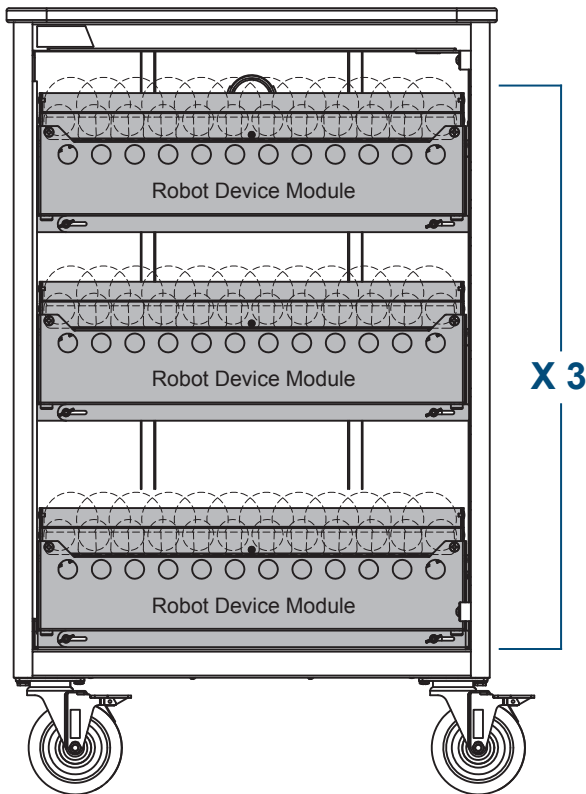
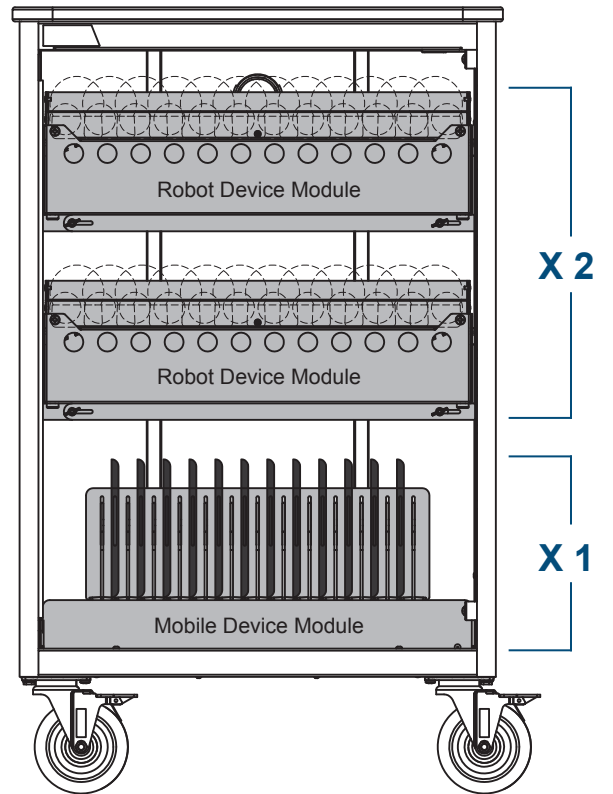
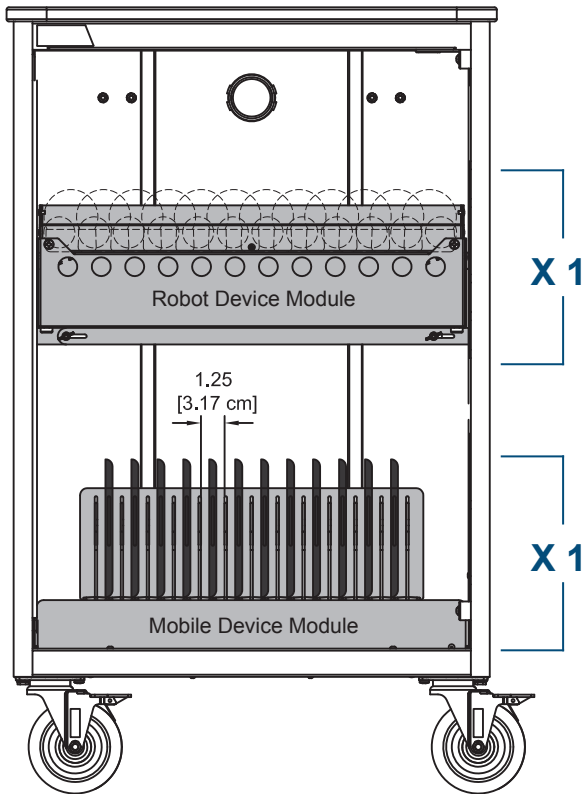

Accessories

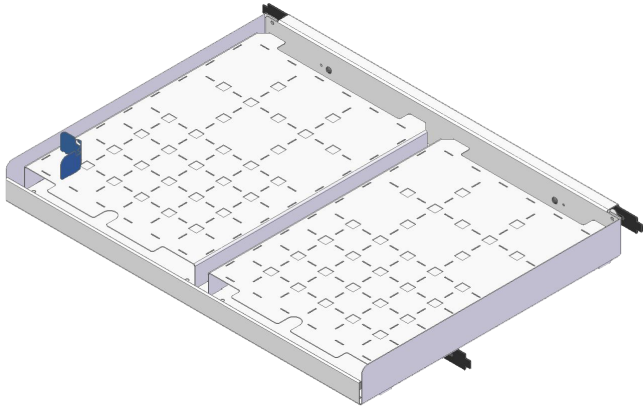

S2 Module

55526H0 - no power

55526HC - w/ USB power

- Stores STEM coding robotics
- Universal tray and divider tab system accommodates different sizes and types of robots
- (1) Shelf
- (2) Universal trays
- (20) Divider tabs
- (2) Bar assemblies (for installation into cart)
- USB version adds (2) 6-port USB chargers and (1) splitter

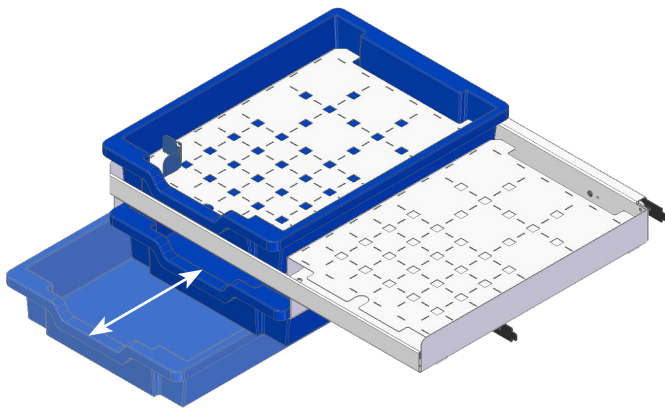

S3 Module

55527H0 - no power

55527HC - w/ USB power

- Stores STEM coding robotics
- Universal tray and divider tab system accommodates different sizes and types of robots
- (2) Bins
- (1) Shelf
- (2) Universal trays
- (20) Divider tabs
- (2) Bar assemblies (for installation into cart)
- USB version adds (2) 6-port USB chargers and (1) splitter

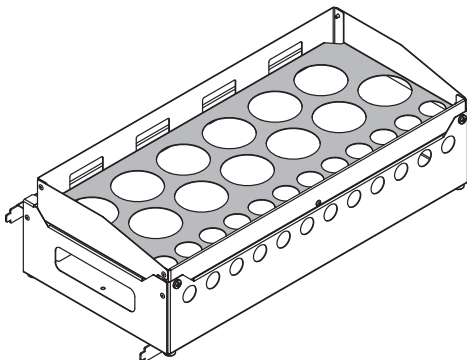

Robot Device Module (w/ Sphero Tray)

55107H0 - no power

55107HC - w/ 12-port USB

- Removable tray holds 12 Sphero, and 12 Sphero Minis
- Designed for tabletop use or installation into select carts
- (2) Bar assemblies (for installation into cart)
- Adjustable height mounting system
- Storage for chargers underneath
- Available with (2) 6-port USB chargers, or no power
- 22.75"W [57.79 cm] x 11.59"D [29.4 cm] x 6.75"H [17.15 cm]
- Unit weight: 19 lb [48.3 kg]
- Shipping weight: 22 lb [10 kg]



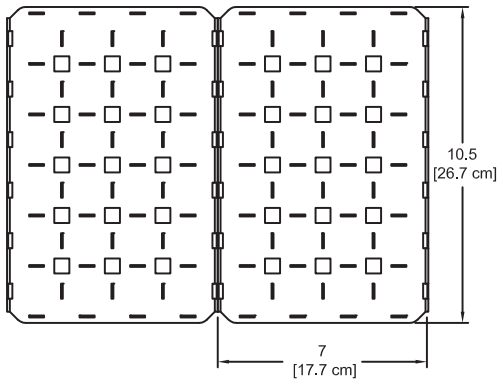

Universal Tray - 55528UWA

- Offers flexibility-accommodates most robots
- Fits in bottom of blue plastic bin or shelf
- (2) trays included
- Divider tabs not included-see 55530 below
- 10.5"W [26.7 cm] x 7"D [17.8 cm] x .65375"H [1.7 cm]
- Unit weight: .5 lb [.227 kg]
- Shipping weight: 1 lb (.454 kg)

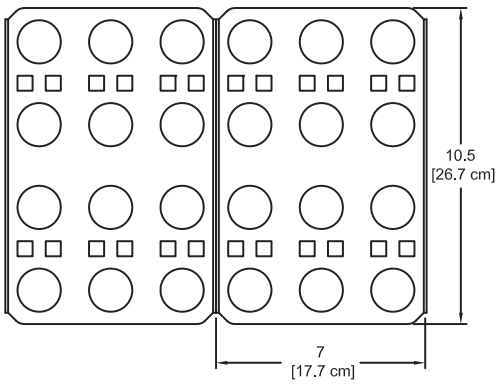
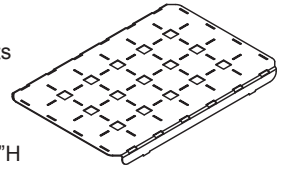

Sphero Mini / Ozobot Tray - 55528UWB

- Holds 24 devices
- (2) trays included
- 10.5"W [26.7 cm] x 7"D [17.8 cm] x .65375"H [1.7 cm]
- Unit weight: .5 lb [.227 kg]
- Shipping weight: 1 lb [.454 kg]

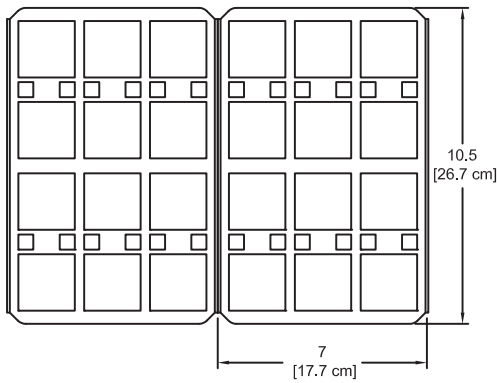
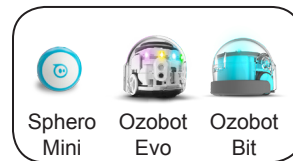
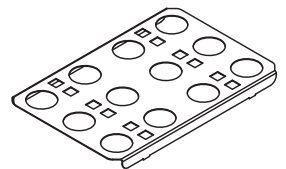

Cubelet Tray - 55528UWC

- Holds 24 devices
- (2) trays included
- 10.5"W [26.7 cm] x 7"D [17.8 cm] x .65375"H [1.7 cm]
- Unit weight: .5 lb [.227 kg]
- Shipping weight: 1 lb (.454 kg)

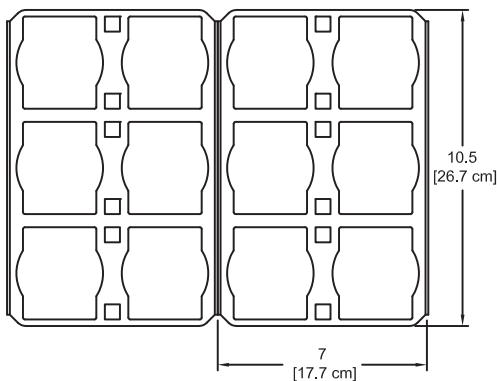
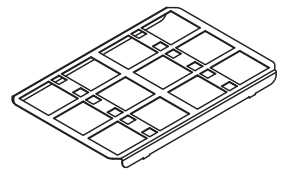

Sprk / Bolt / Dot Tray - 55528UWD

- Holds 12 devices
- (2) trays included
- 10.5"W [26.7 cm] x 7"D [17.8 cm] x .65375"H [1.7 cm]
- Unit weight: .5 lb [.227 kg]
- Shipping weight: 1 lb [.454 kg]

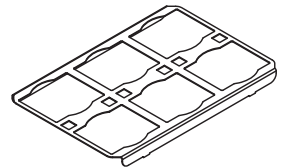

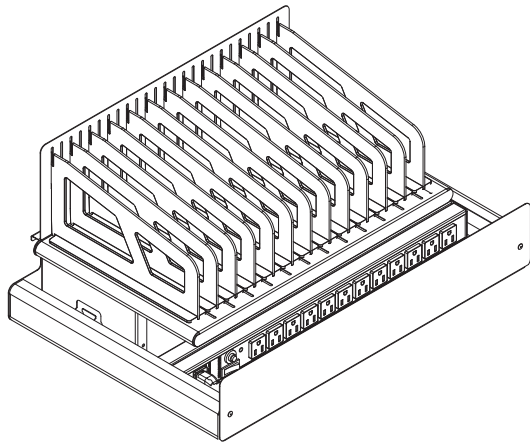

Mobile Device Charging Module

55506H0 - no power

55506HA - w/ 12-outlet AC power strip

55506HC - w/ 12-port USB

- Stores and charges 12 tablets, phones, Chromebooks, or notebooks
- Designed for tabletop use or installation into select carts
- (2) bar assemblies included
- Device bay: 1.25"W [3.17 cm] x 18.49"D [47 cm] x 11.4"H [29 cm]
- Storage for chargers underneath
- Available with 12-outlet AC power strip, (2) 6-port USB chargers, or no power
- Adjustable height mounting system
- 22.75"W [57.79 cm] x 16.125"D [41 cm] x 10.219"H [26 cm]
- Unit weight: 17.36 lb [7.9 kg]
- Shipping weight: 23.65 lb [10.7 kg] - w/ 12-port USB

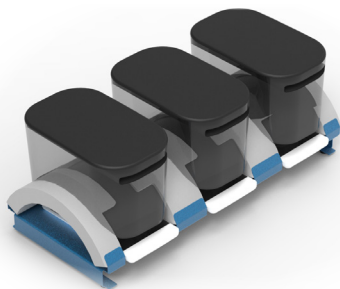

VR Module

55519LB0

55519LB1 - w/ USB Power

- Stores, charges, and transports VR goggles and phones
- Foam arch accommodates different sizes and types of goggles
- Rubber feet prevent tabletop scratches
- Unit weight: .03 lb [13.6 g]
- Shipping weight: 1 lb [454 g]

*VR Goggles and phones not included.

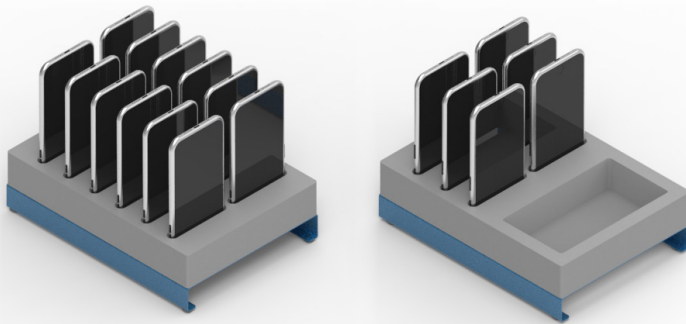

Phone Modules

55505A0 - 6-slot / no power

55505AD - 6-slot w/ USB power

55505B0 - 12-slot / no power

55505B1 - 12-slot w/ USB power

- Stores, charges, and transports phones
- Foam storage slots protect phones
- Rubber feet prevent tabletop scratches

*Phones not included.

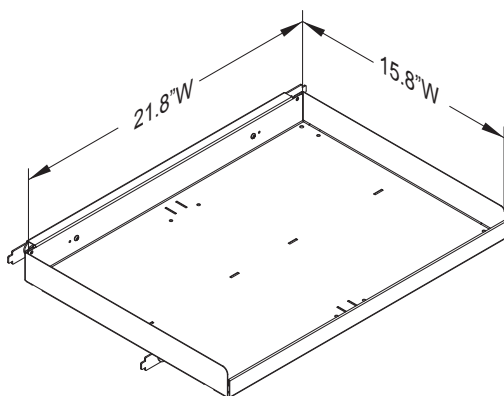

Accessory Shelf

55515UW - White

55515B - Black

- Accommodates up to (3) VR modules per shelf
- Designed for installation into select carts
- (2) bar assemblies included
- Internal dims: 21.8"W [55.4 cm] x 15.8"D [40.1 cm]
- 20ga steel
- Available in White or Black
- Unit weight: 9.75 lb [4.8 kg]
- Shipping weight: 10.25 lb [4.6 kg]

(3) VR Modules
(not included)

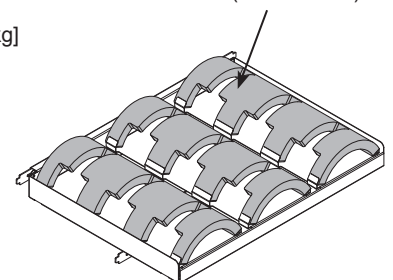

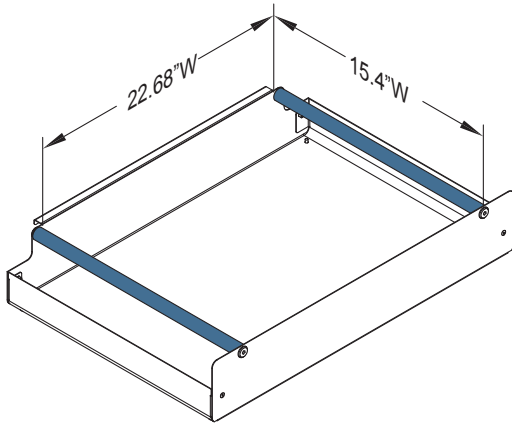

Large Caddy - 55520UWLB

- Accommodates up to (2) VR or phone modules
- Designed for tabletop use or installation into select carts
- (2) bar assemblies included
- Handles provide easy transport
- Rubber feet prevent tabletop scratches
- Internal dims: 22.68"W [57.6 cm] x 15.4"D [39.1 cm]
- 20ga steel
- White with light blue powder coated handles
- Unit weight: 10.5 lb [4.8 kg]
- Shipping weight: 12 lb [5.4 kg]

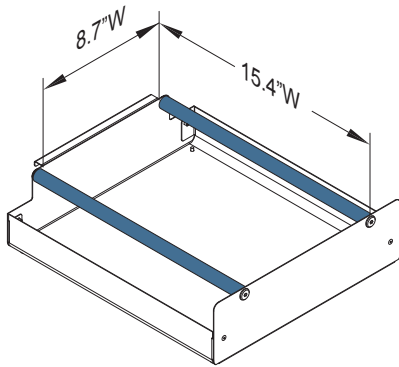
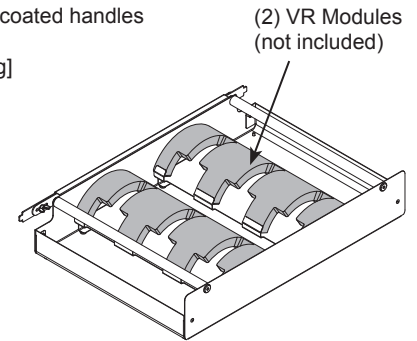

Small Caddy - 55521UWLB

- Accommodates (1) VR or phone module
- Designed for tabletop use or installation into select carts
- (2) bar assemblies included
- Handles provide easy transport
- Rubber feet prevent tabletop scratches
- Internal dims: 8.7"W [22 cm] x 15.4"D [39.1 cm]
- 20ga steel
- White with light blue powder coated handles
- Unit weight: 10.5 lb [4.8 kg]
- Shipping weight: 12 lb [5.4 kg]

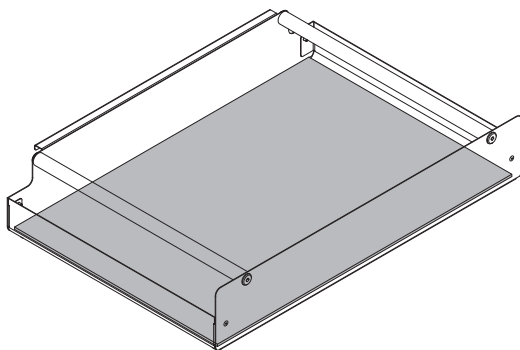
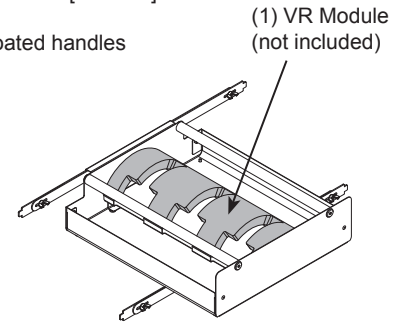

Foam Liner for Large Caddy - 55524

- Cushions modules and items placed into caddy
- 22.25"W [56.5 cm] x 15.3125"D [38.9 cm] x .125" thick [3.2mm]
- Unit weight: .03 lb [13.6 g]
- Shipping weight: 1 lb [454 g]

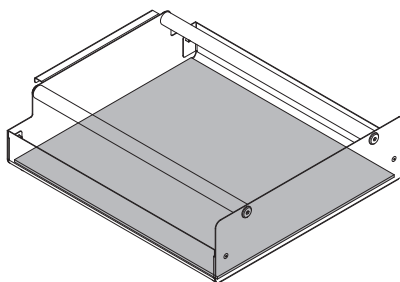

Foam Liner for Small Caddy - 55523

- Cushions modules and items placed into caddy
- 13.5"W [34.3 cm] x 15.3125"D [38.9 cm] x .125" thick [3.2mm]
- Unit weight: .03 lb [13.6 g]
- Shipping weight: 1 lb [454 g]

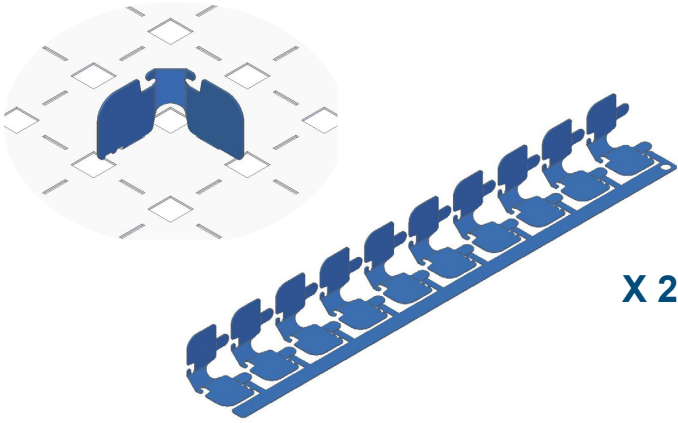

Divider Tabs - 55530LB

- For use with universal trays only
- Provides semi-permanent areas for robots on the universal tray
- Provides charge cord management
- 20ga steel
- (20) divider tabs included in two bar assemblies
- Light blue powdercoat
- Unit weight: .8 oz [23g]
- Shipping weight: 16 oz [454g]



USB charger 6-port - 55522

- For charging robots
- Mounts under tray or on shelf
- 6 USB ports (up to 2.4A per port)
- 60W, 12A max
- 5' detachable power cord
- UL-certified
- 3.9" [99mm] x 2.8" [70mm] x 1" [26mm]
- Unit weight: 6.7 oz [190g]
- Shipping weight: 16 oz [454g]

For charging only-no data



USB charger 10-port - 55529

- For charging robots
- Mounts under tray or on shelf
- 10 USB ports (up to 2.4A per port)
- 60W, 12A max
- 5' detachable power cord
- 4.4" [112mm] x 2.7" [68mm] x 1.1" [27mm]
- Unit weight: 7.7 oz [218g]
- Shipping weight: 16 oz [454g]

For charging only-no data



Splitter - 55531

- Allows two USB chargers to be powered from a single cord
- (1) C8 male to (2) C7 female
- Length: 12" [30 cm]
- Unit weight: 12.8 oz [362g]
- Shipping weight: 16 oz [454g]

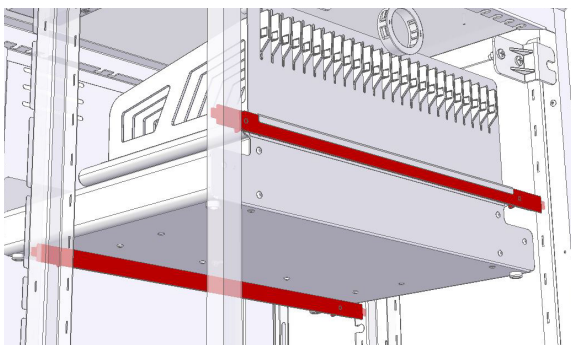

Device Module Bar Kit - 95011

- For mounting modules into select carts
- (2) bar assemblies included
- Shipping weight: 1 lb [.45 kg]

See spectrumfurniture.com for the latest accessories and detailed warranty information.

Warranty

We will make it right for you!

Spectrum is committed to provide complete customer satisfaction. Each of our products is manufactured from the best materials available and each product is stringently monitored throughout the production process through our Quality Management System.

We expressly warrant that Spectrum products will be of good quality and workmanship and free from defect for the period set out in the warranty table below from the date of delivery. This warranty shall not apply to defects or damage resulting from normal wear and tear, misuse, or unintended use, failure to follow instructions related to the product's installation or intended use, abuse, neglect, improper care, modification or repair not authorized by Spectrum, or any other cause outside the control of Spectrum. Spectrum will, at its sole option, either repair or replace the defective product.

This warranty is exclusive; no other warranty, written or oral, is expressed or implied. This warranty is given by Spectrum to Buyer or Buyer third party end user and to no other person or legal entity. No Spectrum dealer, distributor, partner, reseller, agent or employee is authorized to make any modification or addition to this warranty.

NOTWITHSTANDING ANYTHING TO THE CONTRARY, SPECTRUM WILL NOT UNDER ANY CIRCUMSTANCES BE LIABLE FOR INDIRECT OR LIQUIDATED DAMAGES, INCLUDING CONSEQUENTIAL, INCIDENTAL AND SPECIAL DAMAGES. IN NO EVENT SHALL SPECTRUM'S LIABILITY, WHETHER UNDER CONTRACT OR WARRANTY, IN TORT OR OTHERWISE, EXCEED THE PURCHASE PRICE RECEIVED BY SPECTRUM FOR THE PRODUCT AT ISSUE AND "RECALL ACTION" EXPENSES. SPECTRUM SHALL NOT BE SUBJECT TO ANY OTHER OBLIGATIONS OR LIABILITIES, WHETHER ARISING OUT OF BREACH OF CONTRACT, WARRANTY, TORT (INCLUDING NEGLIGENCE AND STRICT LIABILITY) OR OTHER THEORIES OF LAW, WITH RESPECT TO PRODUCTS SOLD OR SERVICES RENDERED BY SPECTRUM, OR ANY UNDERTAKINGS, ACTS OR OMISSIONS RELATING THERETO.

Our Customer Service Department is ready to provide immediate attention to any questions, comments or concerns. They are available to answer your calls Monday through Friday from 7 am to 5 pm CST. In addition your product comments or concerns are welcome via e-mail at: spectrum@spectrumfurniture.com.

Warranty Table

Item	Warranty Period
Desk, table, cart and lectern chassis	10 Years
Electrical	2 Years
Flat panel monitor arms / gas spring / general parts	2 Years
Adjustable crank / electric legs and accessories	2 Years
Flat panel desk gas spring cylinders	2 Years
Height adjustable columns, lifts & accessories	2 Years
Casters & wheels	2 Years
Keyboard, mouse, trays	2 Years
Locks & keys	2 Years
Tubs, totes and other accessories	1 Year
Chairs Structural components, including gas cylinders, wood, metal and plastic parts (i.e., chair frames, bases and control handles)	7 Years
Consumable items (i.e., casters, glides, etc.)	5 Years
In-stock upholstery	5 Years
Customer supplied material	No Warranty

