

Assembly Instructions

⚠ Important ⚠

Before you begin, read and comply with all safety and operating instructions, and ensure all parts and correct quantities are included.

Any parts damaged during shipment must be reported within 5 days of receipt. To report information regarding missing parts or damage, to purchase parts or accessories, or if you have any questions, please contact us.

www.spectrumfurniture.com
800-235-1262, 715-723-6750

Thank you for purchasing Spectrum products!

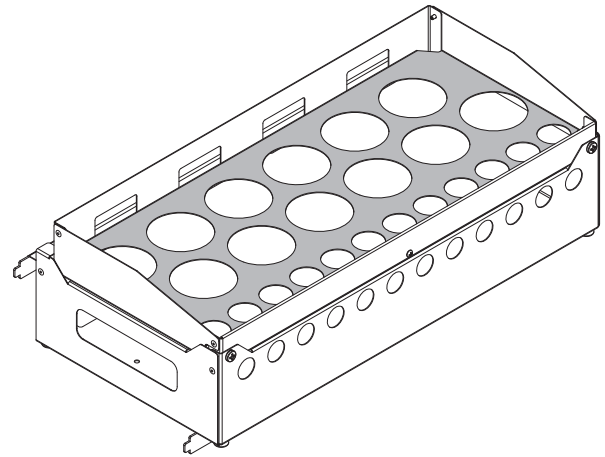

Robot Device Charging Module 55107

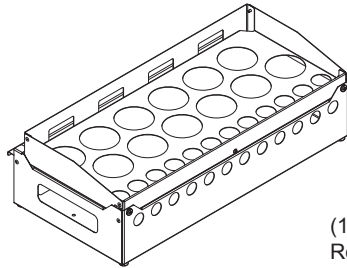

(1) 0144113
Robot charging module

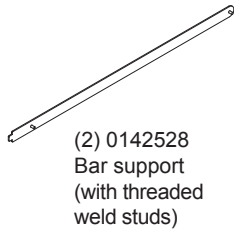

(2) 0142528
Bar support
(with threaded
weld studs)

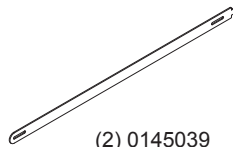

(2) 0145039
Bar support
B-side
(with slots)



(4) 056284
8-32 Wing nut

The Robot Charging Module can store and charge up to 12 Sphero[®] robots, and 12 Sphero Minis[®]. The tray can be swapped for other robot types*.

Tools
Required



*Contact Spectrum for a list of available trays or custom options.

1 Install chargers

1. Remove the (2) 1/4-20 x 5/8" PHM screws and remove the tray assembly. **Figure 1.**
2. Place chargers inside module and plug into power strip or USB hub (not included).
3. Replace tray assembly and secure with previously removed screws.

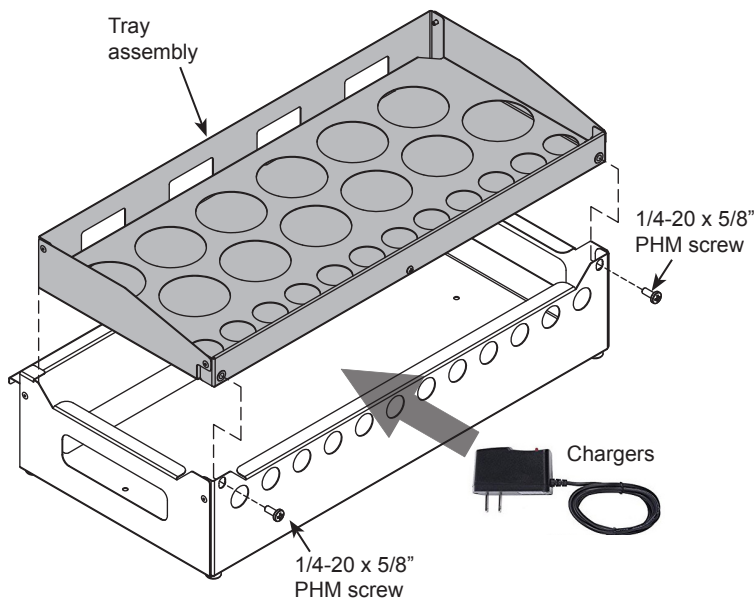

Figure 1

2 Route cords

1. Remove (2) #8 x 3/8" PHSM screws and remove robot tray.
2. Route charge cords through the openings in the module. Be sure to leave enough slack in the cords to reach all robots in the tray. **Figure 2.**
3. Replace tray and screws.

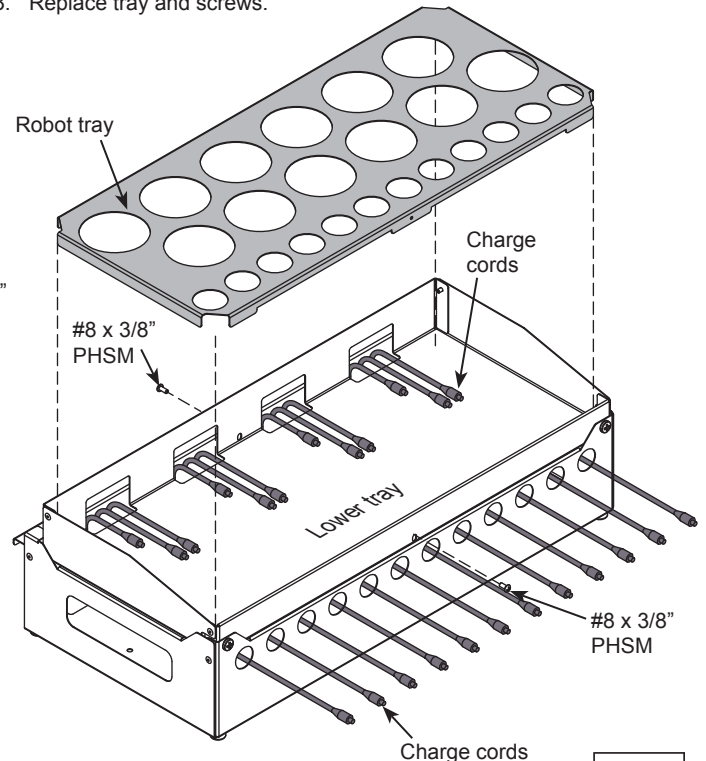

Figure 2

3 Install robots

1. Plug charge cords into robot bases. **Figure 3.**
2. Place robots* into tray cutouts.

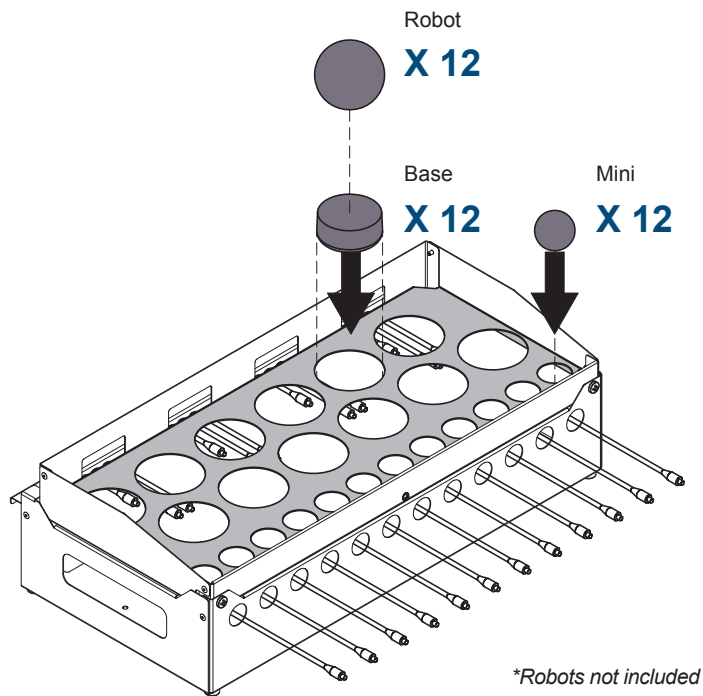

Figure 3

4 Connect charge cords

1. Plug charge cords into mini robots. **Figure 4.**

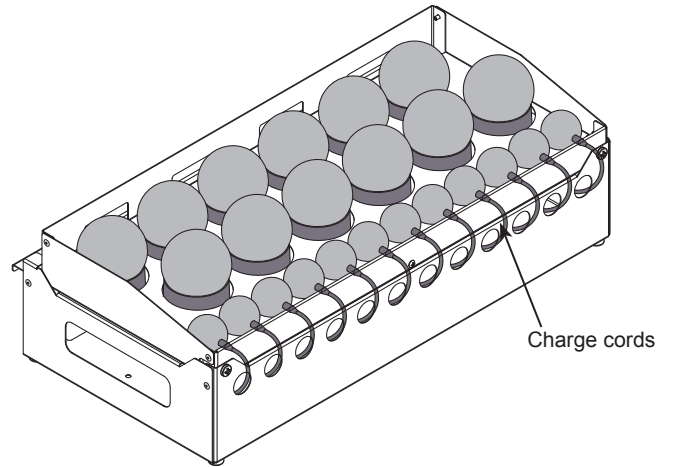
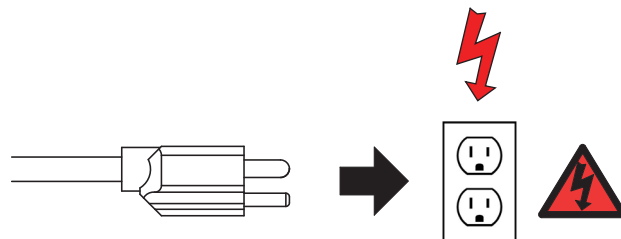

Figure 4



⚠ CAUTION ⚠

While the rubber feet on the bottom of the module prevent scratching of surfaces the module is placed on, screw heads protruding under the unit can still possibly scratch these surfaces in some circumstances.

Place the module on a level surface using all 4 rubber feet. Do not drag or slide the module across tables or worksurfaces. Use caution when moving. Always remove all devices to reduce weight, and unplug power strip prior to moving.

Installing module into cart or TechCenter - optional

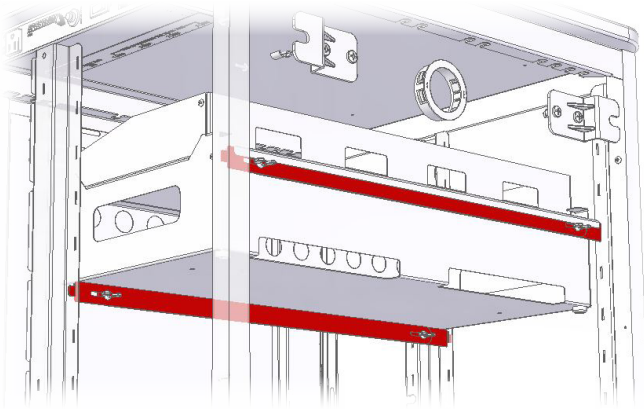

5 Assemble bars

1. The bars should be assembled with the tabs facing away from each other as shown in **Figure 5**.
2. Loosen the (2) wingnuts slightly.
3. Repeat for the 2nd set of bars.

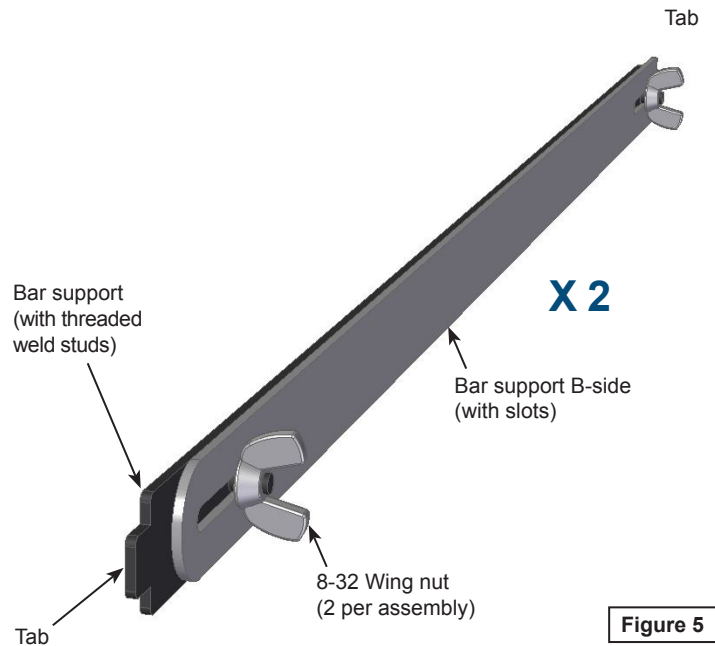

Figure 5

6 Installing bars

1. Determine the approximate location (height) you would like the module to be mounted. The rear bar is (2) slots higher than the front.
2. Insert one tab into a slot in the left slotted upright. **Figure 6**.
3. Insert the opposite tab into the corresponding right slotted upright and fully extend the bar assembly into place.
4. Lock the extended position of the bars by securely tightening the (2) wingnuts. Be sure both wingnuts are tight.
5. Repeat for the 2nd set of bars.

Note: When determining the location of the module, be sure the module will clear any obstructions that may be inside the cabinet and enough clearance (height) is provided for all module devices.

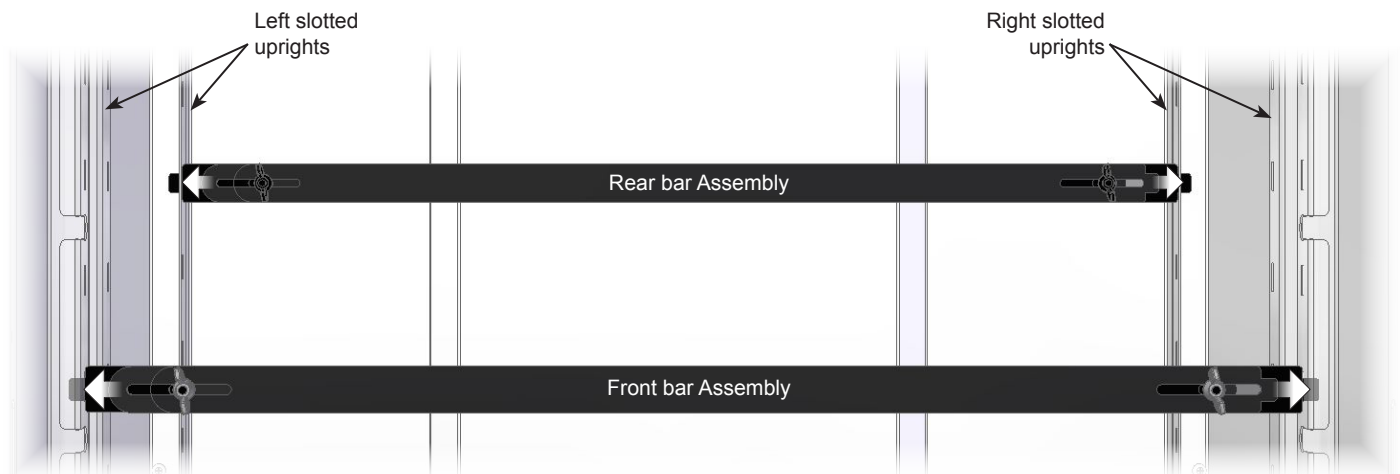

Figure 6

7 Installing module

1. Carefully set the empty module onto both sets of bars. Be sure the rear channel "hooks" the rear set of bars fully. **Figure 7.**

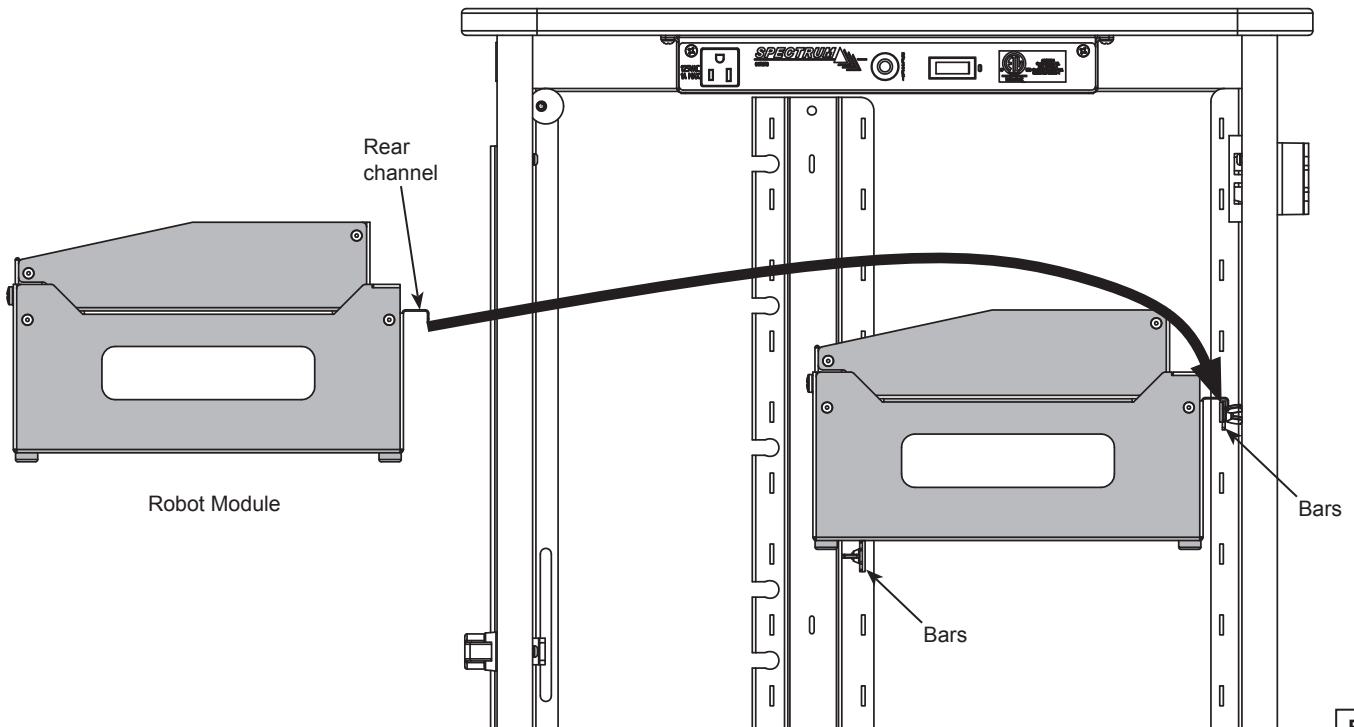

Figure 7