

# Assembly Instructions

## ⚠ Important ⚠

Before you begin, read and comply with all safety and operating instructions, and ensure all parts and correct quantities are included.

Any parts damaged during shipment must be reported within 5 days of receipt. To report information regarding missing parts or damage, to purchase parts or accessories, or if you have any questions, please contact us.

[www.spectrumfurniture.com](http://www.spectrumfurniture.com)  
800-235-1262, 715-723-6750

Thank you for purchasing Spectrum products!

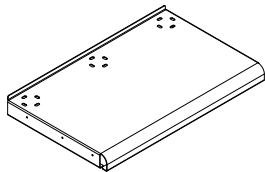

(1) 0118160  
Keyboard  
Tray



(6) 0100167  
8-32 x 1/2" PH  
thread-cutting  
screw

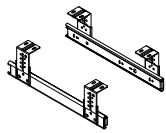

(1) 050092  
12" Slide set



(8) 037542  
#8 x 5/8" PHSM

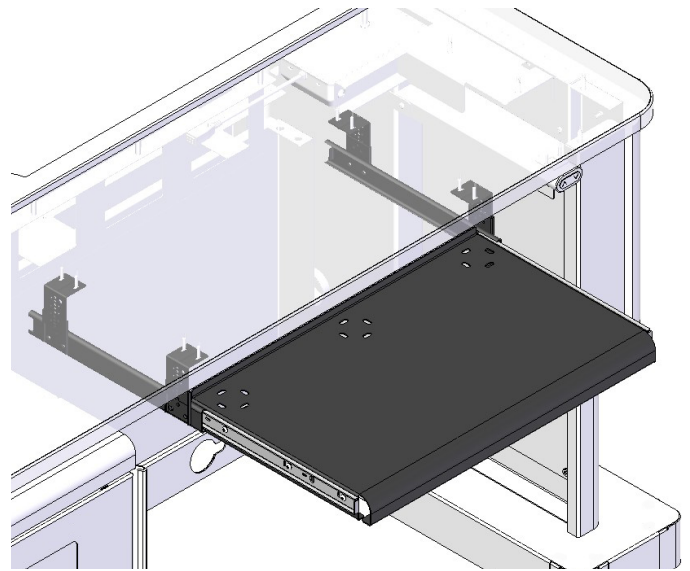

## Keyboard Tray for Freedom XRS Elite™ 55334

### 1. Assemble Slide Brackets

1. Attach the 'L' brackets to each outer slide with screws (included with slides). The brackets need to be attached "inboard" (facing each other). **Figure 1A.** Multiple height positions / mounting holes are available with the brackets-use the same hole position on all 4 brackets.
2. Tighten the bracket screws securely.
3. Separate the inner from the outer slides using the black levers.
4. Raise the lectern up all the way and unplug the power cord.
5. Determine which side of the lectern you want the keyboard tray installed (left or right-side). The tray should be installed under the worksurface on the side opposite the rack cabinet using the pre-drilled worksurface holes.
6. Attach each outer slide ('L' brackets) to the worksurface using (4) #8 x 5/8" PHSM screws and pre-drilled worksurface holes. Tighten the screws completely on one slide only-leave the screws other slide slightly loose. **Figure 1B.**

Tools  
Required



Phillips  
Screwdriver

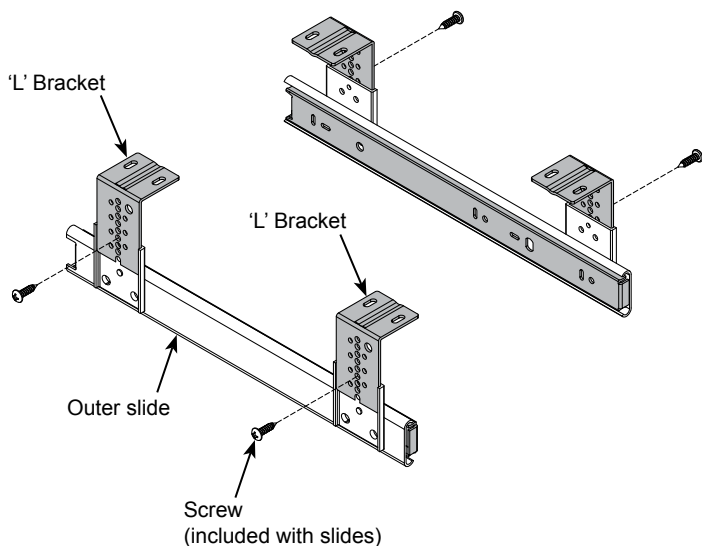

Figure 1A

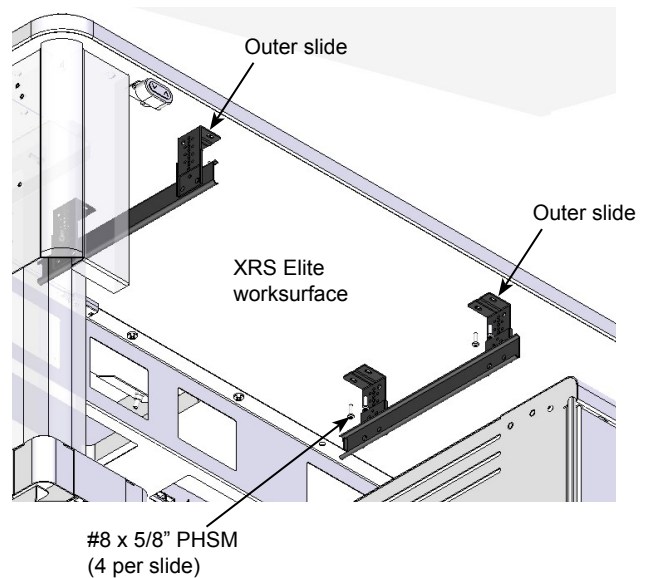
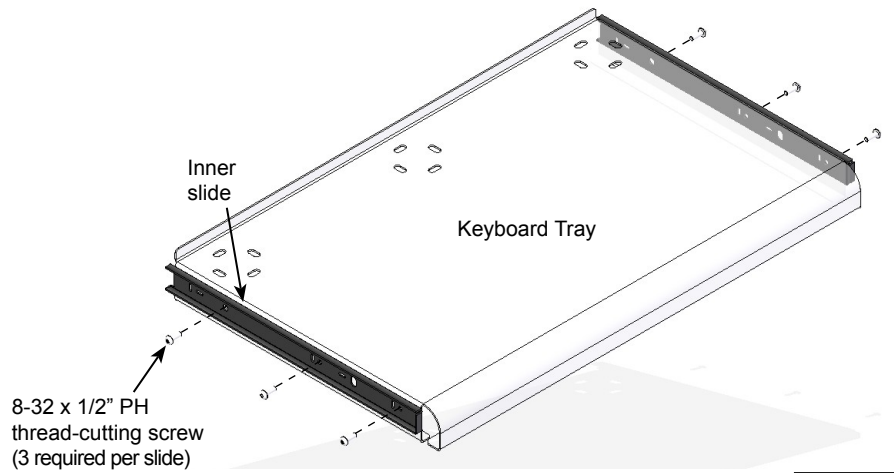

Figure 1B

Note: The keyboard tray may protrude up to a maximum of 3.9" [10 cm] below the worksurface. If the lectern is used for ADA use, a higher adjusted worksurface will be necessary to provide ADA leg clearance. The 'L' brackets can also be adjusted to provide varied keyboard heights.

## 2. Attach Inner Slides to Tray

1. Attach each inner left and right slide to the keyboard tray with (3) 8-32 x 1/2" PH thread-cutting screws and tighten securely. **Figure 2.**



## 3. Install Keyboard Tray

1. Align the tray assembly with the installed slides and slide together. **Figure 3.**
2. Open and close (cycle) the tray a few times to ensure parallel and free movement.
3. With the keyboard tray pulled out, securely tighten the (3) loose worksurface slide screws from step 1.

