

Freedom One eLift Workstation For Sprout Pro by HP®

55357-20031

55357-20032

Touchboards

205 Westwood Ave, Long Branch, NJ 07740

Phone: 866-94 BOARDS (26273) / (732)-222-1511

Fax: (732)-222-7088 | E-mail: sales@touchboards.com

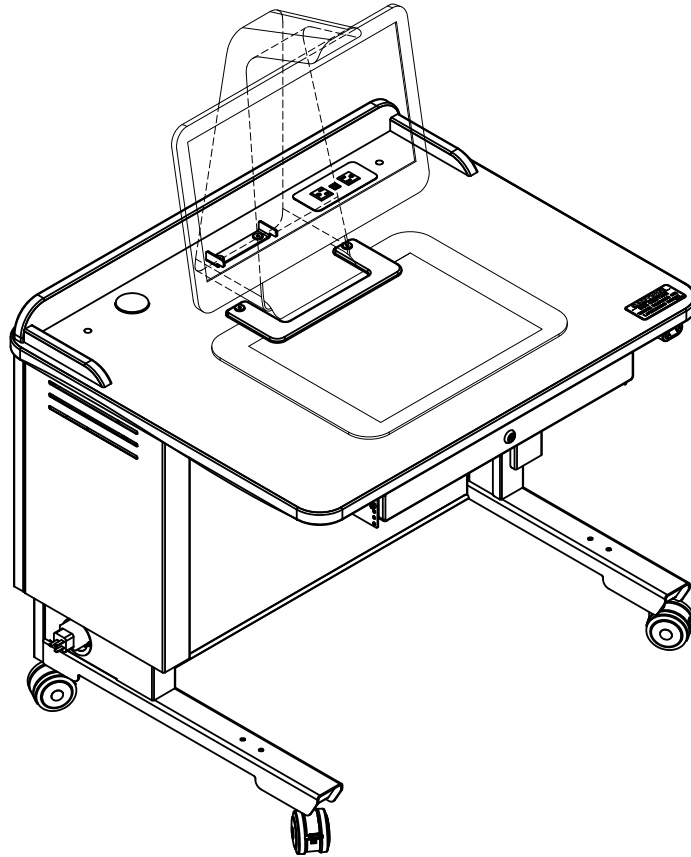

Important

Before using this product:

- Read this manual
- Comply with all safety and operating instructions
- Ensure all parts and correct quantities are included

Any parts damaged during shipment must be reported within 5 days of receipt. To report information regarding missing parts or damage, to purchase parts or accessories, or if you have any questions, please contact us.

Thank you for purchasing Spectrum products!

Spectrum Industries, Inc
925 First Avenue, Chippewa Falls, WI 54729 USA
800 235 1262
715 723 6750
www.spectrumfurniture.com

⚠ Important Safety and Care Instructions ⚠

DANGER - Read all instructions **before** using

⚠ DANGER - General Safety:

1. SAVE THESE INSTRUCTIONS
2. Do not allow children to move.
3. Do not leave unit unattended in areas where children have access.
4. Keep unit locked when unattended.
5. Proceed slowly and carefully when moving.
6. Close supervision is necessary when this furnishing is used by, or near children, invalids, or disabled persons.
7. For indoor use only. Do not install or store where it will be exposed to moisture.
8. Do not block the ventilation openings.
9. Avoid uneven loading of the equipment into the unit. Uneven weight distribution could cause unit to tip when mobile.
10. Do not allow anyone to sit, stand, or climb on the unit.
11. When loading, place heavier objects near the bottom of the unit to avoid tipping.
12. To clean dirty surfaces, use a damp, soft-cloth, or sponge, with mild soap or detergent solution. Do not use harsh solvents or abrasives.
13. Never drop or insert any object into any opening.
14. This unit is intended for institutional, commercial use only.
15. Use this furnishing only for its intended use as described in these instructions. Do not use attachments not recommended by the manufacturer.
16. This unit does not have any user-serviceable parts. If servicing is necessary, please contact Spectrum Industries for assistance.

⚠ DANGER - To reduce the risk of electric shock:

1. This furnishing is only to be used with the power supply unit provided.
2. Always unplug this furnishing from the electrical outlet before cleaning.
3. For added safety, plug the cart into a grounded outlet controlled by a GFI (Ground Fault Interrupter) circuit breaker.
4. Keep the power switch in the OFF position before plugging or unplugging from the wall outlet.
5. Turn devices OFF before plugging them in.
6. This furnishing has a polarized plug (one blade wider than the other). This plug will fit into a polarized outlet only one way. If the plug does not fit fully into the outlet, reverse the plug. If it still does not fit, contact a qualified electrician to install the correct outlet. Do not alter the plug in any way
7. Do not plug the power cord into an extension cord.
8. Inspect the power cord for damage before each use. Do not operate if cord or plug has been damaged, or has come into contact with water.
9. To disconnect power, turn all controls to the OFF position, then remove plug from outlet. Do not pull on cord.
10. Disconnect power before adding or removing components.
11. Do not run power cords across hallways or classrooms. Do not step on, drive over, drag, or place objects on cord. Keep cord away from heated surfaces.
12. If servicing is necessary, please contact Spectrum for assistance.
13. Damaged electrical components can create significant hazards to users and is not covered by the warranty. Repairs should always be performed by a qualified electrician.
14. Electrical devices are not toys. Children are often unaware of the hazards associated with electrical devices. This cart must always be used by adults or with adult supervision.

⚠ WARNING ⚠

Relocating audio and/or video equipment to furniture not specifically designed to support audio and/or video equipment may result in serious injury or death due to the furnishing collapsing or over turning onto a child.

⚠ CAUTION ⚠

Risk of Electric Shock. This unit may have multiple power cords. Unplug all power cords before moving or servicing this furnishing.

⚠ WARNING ⚠

A remote control or toys placed on the furnishing may encourage a child to climb on the furnishing and as a result the furnishing may tip over onto the child. Serious injury or death could occur when children climb on audio and /or video equipment furniture.

⚠ WARNING ⚠

To reduce the risk of burns, fire, electric shock, or injury to persons, unplug from outlet(s) before installing or removing components

⚠ CAUTION ⚠

- Always unplug workstation before working under the worksurface.
- Do not place anything under worksurface when operating lift.
- Use caution when raising or lowering the worksurface!
- Be sure workstation movement does not interfere with objects or people

Hardware

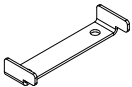

(1) 0131416
Rear security bracket

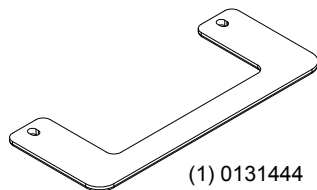

(1) 0131444
Plastic retainer bracket

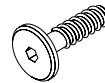

(4) 0102297
7mm x 30mm JCWS



(2) 026059
1/4" Flat steel washer

1. Workstation lift mechanism initial setup, operation, and reset procedure

Preparation:

- Read all instructions before operation.
- Make sure workstation is plugged-in using the 15-foot, 15-amp power cord.
- Locate the "Up" and "Down" control buttons. Control pad is located on the instructor-side under the worksurface front edge on opposite side from rack cabinet.
- Keep clear of pinch points during worksurface movement.

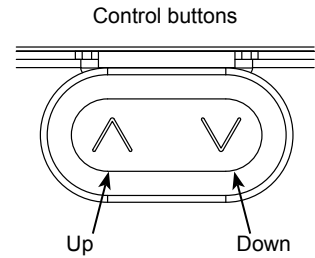

Figure 1A

Normal Operation:

To raise or lower the workstation, press and hold the "up" or "down" arrow keys on the control pad until the worksurface reaches the desired height. The worksurface can be adjusted from 28.5"H (*minimum*) to 42"H (*maximum*).

Note: The workstation has a load-sensing, anti-collision feature programmed into the controller that actively locks out the lift mechanisms when unbalanced loads are encountered; i.e. an obstruction under the worksurface, or weight from a person sitting on one side of the workstation.

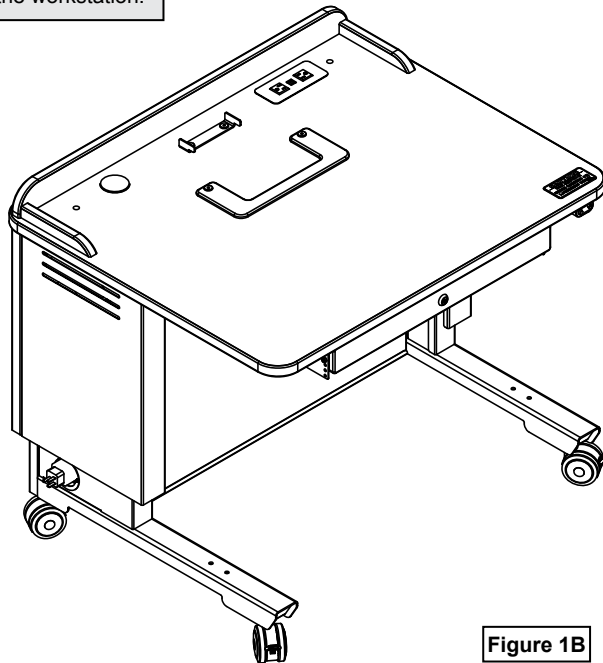
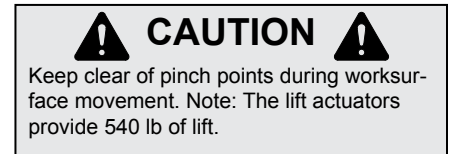
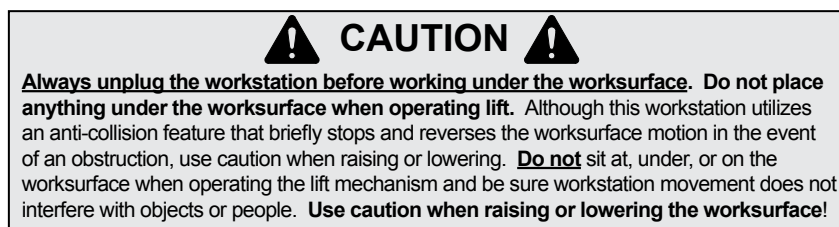

Figure 1B



2. Install security brackets

1. Place computer on worksurface. **Figure 2.**
2. Install rear bracket with (2) 7mm JCWS.
3. Install plastic bracket with (2) 7mm JCWS, and (2) washers under the bracket.
4. Tighten brackets securely.

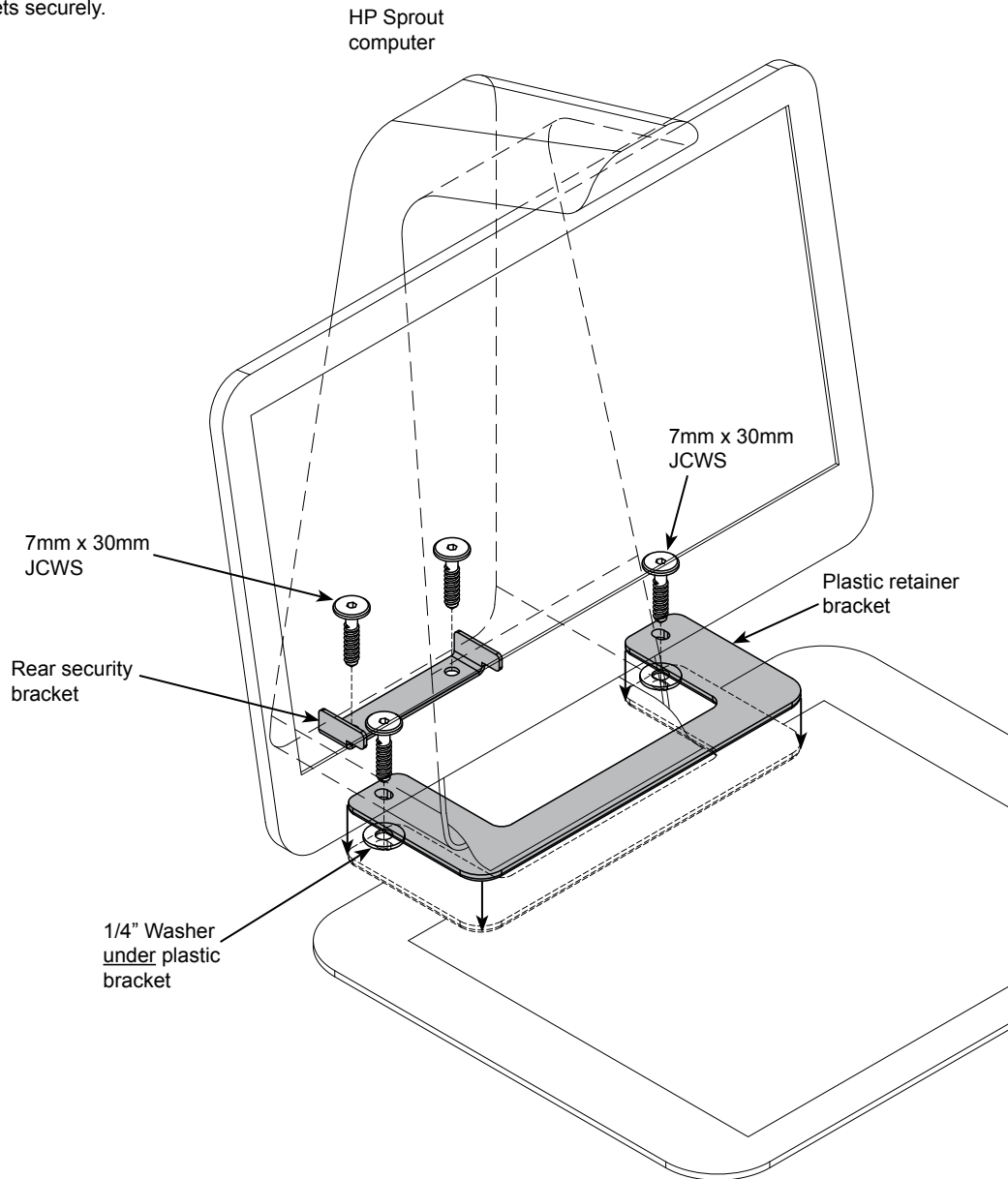
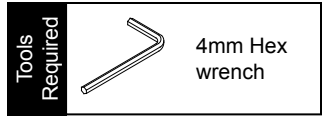

Figure 2

Cord reel option

Select workstations may have the optional cord reel installed. It can be mounted on the left or right-side of the workstation. **Figure 3A.**

! Note: The cord reel is intended to provide temporary access to electrical outlets for Spectrum mobile lecterns. Check local electrical codes prior to use.

Cord reel operation

Operating Instructions:

1. **To latch cord** - Pull cord out to full length. Allow the cord to retract 1-2 feet back into the reel. Pull the cord out slowly. When a 'click' is heard, the cord will latch in place.
2. Plug into 110-125V (single phase), 3-conductor wall outlet.
3. **To release cord** - Unplug from wall outlet. Pull cord out slowly until clicking stops. The latch will release and the cord can be guided back into the reel. Do not allow the cord to fly unrestricted back into the reel.
4. Do not overload or circuit breaker (15-amp maximum) will cut off current. To restore power, remove overload, wait two minutes, then reset the circuit breaker by pressing the button on the back of the 3-prong male power plug.

Maintenance:

1. Unplug cord reel before performing maintenance.
2. Remove dirt and grime as soon as it accumulates on the reel case by using a soft, damp cloth (a mild detergent may be used if needed), being careful not to wet the electrical plug. Never immerse any part of the unit in any solution to clean. **DO NOT** use solvents such as gasoline, turpentine, etc. to clean unit.
3. Keep cord clean to assure smoothest automatic retraction. Simply pull cord to its full length and allow to retract through a dampened rag. Pull out full length again and sprinkle cord with talcum powder.

Specifications:

1875W, 15A, 125V, 15' retractable, 12 AWG with breaker, UL Listed

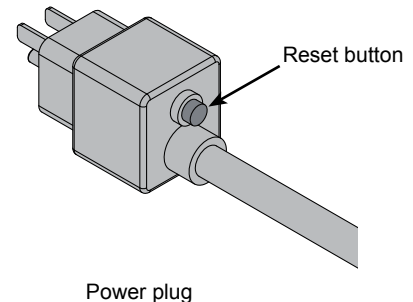
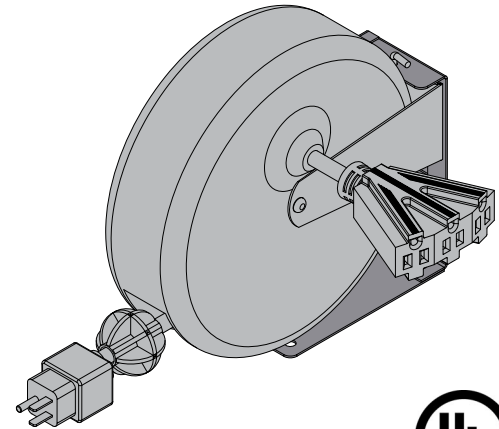

! WARNING **!**

- This cord reel is intended for general indoor use only. It is not intended to be used in potentially dangerous locations such as flammable or explosive atmospheres.
- The cord reel is not waterproof and not intended for use in potentially wet locations.
- Do not overload (15-amp maximum).

CAUTION

1. USE IN COVERED AREAS. OUT OF RAIN & WEATHER
2. NOT FOR USE IN AREAS REQUIRING EXPLOSION-PROOF FIXTURES.
3. REELS WITH ELECTRICAL OUTLETS:
 - Do not overload - See instruction manual for amperage ratings.
 - Pull entire cord from reel when using outlet.
4. WHEN HANGING REEL on ceiling (See Instruction Manual):
 - BY HOOK - Close hook with pliers to prevent reel from coming down.
 - BRACKET & PIN - With reel in place, bend end of "L" shaped pin to PREVENT PIN FALLING OUT and reel falling.
5. INSPECT CORD OFTEN and replace if damaged.
6. READ INSTRUCTION MANUAL BEFORE INSTALLING OR USING.
7. UNPLUG BEFORE PERFORMING SERVICE.

Switching cord reel position

Tools Required

- Phillips screwdriver
- Pliers

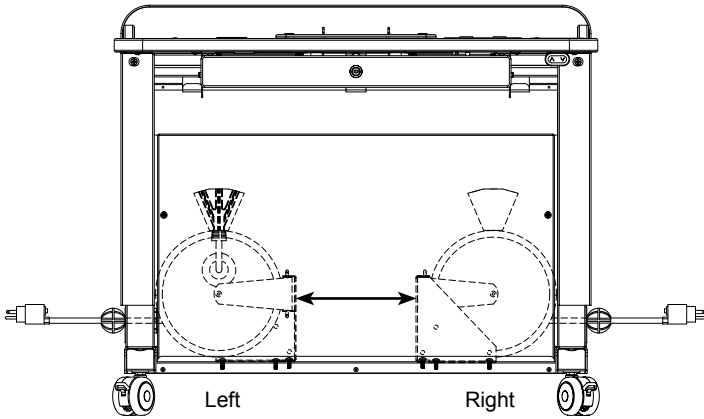

Figure 3A

1. Remove the student-side panel under the worksurface (eLift version). **Figure 3B.**
2. Detach the control box and hook and loop strips from the base panel.

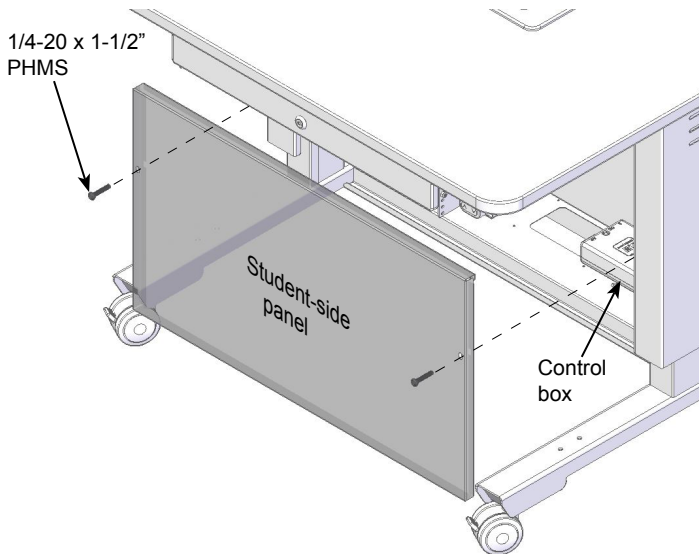

Figure 3B

7. Set the cord reel into the bracket and secure with the connector pin. Use pliers to bend the straight end of the connector pin to approximately 45°. **Figure 3E.**

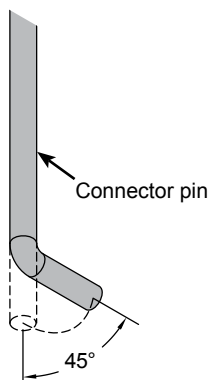
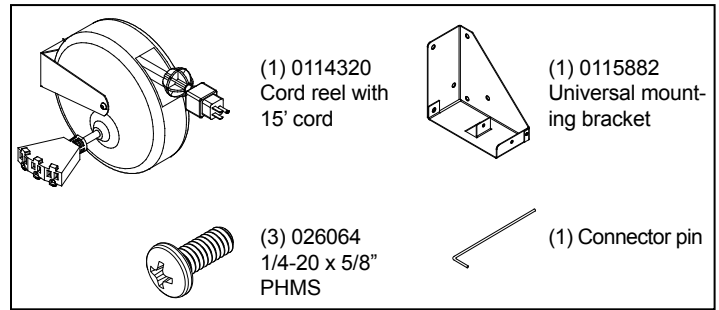

Figure 3E



3. Straighten the connector pin with a pliers and remove. **Figure 3C.**
4. Lift the cord reel out of the bracket.
5. Remove the (3) 1/4-20 x 5/8" PHM screws attaching the bracket. **Figure 3D.**
6. Move the bracket to the opposite side and attach with the (3) previously removed screws.

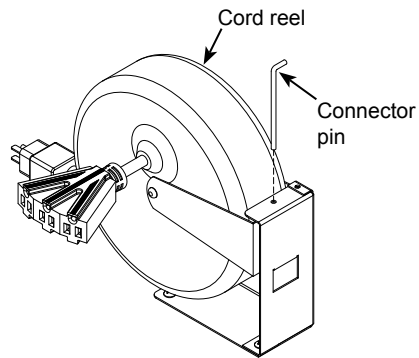

Figure 3C

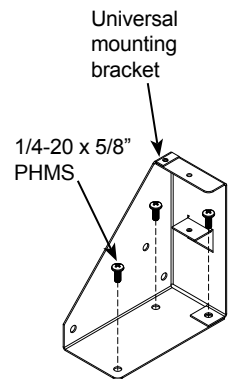

Figure 3D

8. Route the power cord out the side grommet. **Figure 3F.**
9. Locate the control box to the side opposite the cord reel.

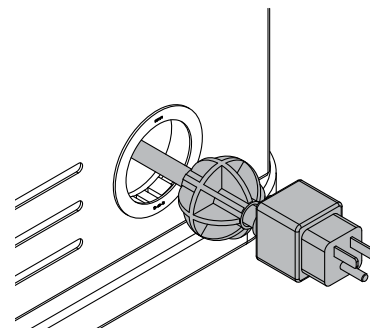

Figure 3F

Wiring Diagram

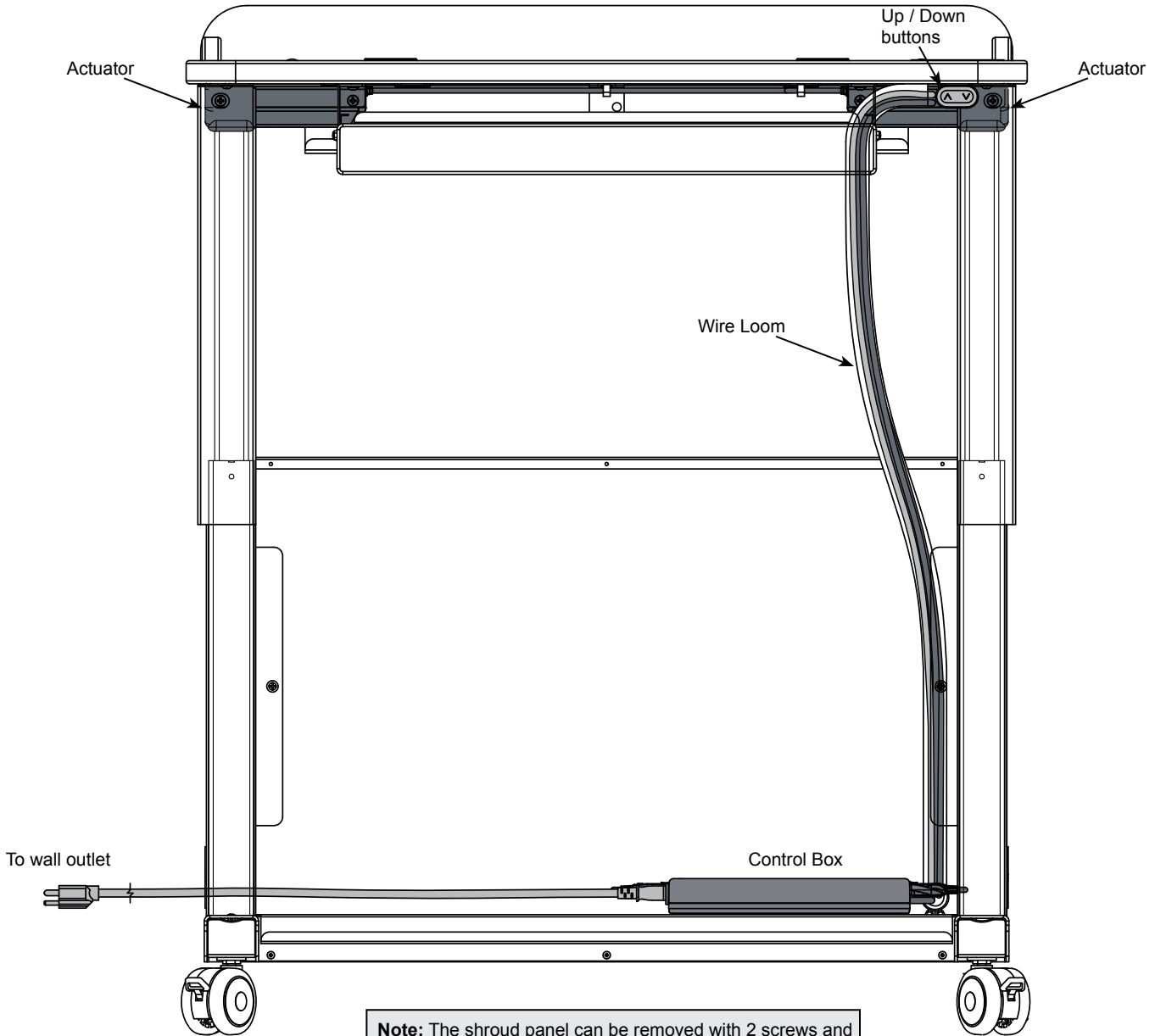

Figure 6

Moving and parking the workstation

- Before moving, unplug and secure all power cords.
- Close and lock doors.
- Remove any items from the top of the worksurface.
- Unlock the casters.
- Push slowly and carefully. Do not move over uneven or irregular surfaces.
- Do not allow children to move.
- Lock the casters after moving.
- Do not park unit in areas of heavy traffic.
- Do not run power cords across hallways, classrooms, or other areas where they will be walked on.
- Do not leave unit unattended in areas where children have access.
- Keep doors closed and locked whenever unit is unattended or parked.
- Keep casters locked whenever the workstation is unattended.

Electric actuator information

Warning!

Failure to comply with these instructions may result in accidents involving serious personal injury. Failing to follow these instructions can result in the product being damaged or being destroyed.

Safety Information

General

Safe use of the system is possible only when the operating instructions are read completely and the instructions contained are strictly observed. Failure to comply with instructions marked with the "NOTE" symbol may result in serious damage to the system or one of its components.

- It is important for everyone who is to connect, install, or use the systems to have the necessary information and access to this User Manual. Follow the instructions for mounting – risk of injury if these instructions are not followed.
- The appliance is not intended for use by young children or infirm persons without supervision.
- If there is visible damage on the product it must not be installed.
- Note that during construction of applications, in which the actuator is to be fitted, there must be no possibility of personal injury, for example the squeezing of fingers or arms.

 **Assure free space for movement of application in both directions to avoid blockade.**

Before installation, re-installation, or troubleshooting:

- Stop the DL5/DL6
- Pull out the mains plug.
- Relieve the DL5/DL6 of any loads, which may be released during the work.

Before start-up:

- Make sure that the system has been installed as instructed in this User Manual.
- Make sure that the voltage of the control box is correct before the system is connected to the mains.
- System connection. The individual parts must be connected before the control box is connected to the mains. See the User Manual for LINAK actuators, if necessary.

During operation

- If the control box makes unusual noise or smells, switch off the mains voltage immediately.
- Take care that the cables are not damaged.
- Unplug the mains cable on mobile equipment before it is moved.
- The products must only be used in an environment, that corresponds to their IP protection.

Misc.

The actuator system has a sound level below 55dB(A) in typical applications.

Updated manuals and declarations can always be found here:
www.linak.com/desklina

Label for DL6



Only for EU markets

- This appliance can be used by children aged from 8 years and above and persons with reduced physical, sensory or mental capabilities or lack of experience and knowledge if they have given supervision or instruction concerning use of the appliance in a safe way and understand the hazards involved.
- Children shall not play with the appliance. Cleaning and user maintenance shall not be made by children without supervision.

Only for Non-EU markets

- Persons who do not have the necessary experience or knowledge of the product/products must not use the product/products. Besides, persons with reduced physical, sensory or mental abilities must not use the product/products, unless they are under surveillance or they have been thoroughly instructed in the use of the apparatus by a person who is responsible for the safety of these persons.
- Moreover, children must be under surveillance to ensure that they do not play with the product.

Misuse

- Do not overload the actuators – this can cause danger of personal injury and damage to the system.
- Do not use the actuator system for lifting persons. Do not sit or stand on a table while operating – risk of personal injury.
- Do not use the system in environments other than the intended indoor use.

Repairs

In order to avoid the risk of malfunction, all DESKLINE® repairs must only be carried out by authorised LINAK workshops or repairers, as special tools must be used and special gaskets must be fitted. Lifting units under warranty must also be returned to authorised LINAK workshops.



Warning! If any of the DESKLINE® products are opened, there will be a risk of subsequent malfunction.



Warning! The DESKLINE® systems do not withstand cutting oil.



C/N 120690
 C/N 9901916
 C/N 4008003
 C/N 4008004
 C/N 4008005
 C/N 4008671
 C/N 4009507

Note: Use the included control box only-do not connect other control boxes to this product.

Label for CBD6S 200W (SMPS)



Misc. on the DESKLINE® DL5/DL6 system

This system is a DESKLINE system developed for desks and for indoor use in offices. Do not use it in industrial kitchens or in other environments that have to be cleaned with aggressive detergents. Do not bolt the legs to the floor so that free movement is prevented. This could cause serious damage to the legs in fault situations.

Warranty - 60 months on DESKLINE® (NEW)

This will be valid for all DESKLINE products produced after the 1st of May 2015.

Products produced before 1st of May 2015 will still be covered by 36 months.

Products used in DESKLINE application: If these products are used in another application, they will be covered by 18 months warranty.

If there is any doubt that returned products are within the warranty period it is to be treated as if they are covered by the warranty. We recommend that you use the date of the control box or actuator as reference if possible. We will have our purchase number printed on the label.

Maintenance

Clean dust and dirt on the outside of the system at appropriate intervals and inspect them for damage and breaks. Inspect the connections, cables, and plugs and check for correct functioning as well as fixing points.

Service of double-insulated products:



Class II

A Class II or **double insulated** electrical appliance is one which has been designed in such a way that it does not require a safety connection to electrical earth (US: ground).

The basic requirement is that no single failure can result in dangerous voltage becoming exposed so that it might cause an electric shock and that this is achieved without relying on an earthed metal casing. This is usually achieved at least in part by having two layers of insulating material surrounding live parts or by using reinforced insulation.

There is no earthing / grounding means provided on the product, and no earthing/grounding means is to be added to the product.

In Europe, a double insulated appliance must be labelled "Class II", "double insulated" or bear the double insulation symbol (a square inside another square).

Servicing a double-insulated product requires extreme care and knowledge of the system, and is to be done only by qualified service personnel. Replacement parts for a double-insulated product must be identical to the parts they replace.



The cleaners and disinfectants must not be highly alkaline or acidic (pH value 6-8).

Description of the DESKLINE® DL5/DL6 system

Each DESKLINE® DL5/DL6 lifting units is equipped with a motor and parallel / memory drive is ensured by means of software in the CBD6S (SMPS) that also takes account of oblique load on the desk. Soft start and stop are also part of this software, which ensures a soft start and stop when adjusting the desk.

Application of the DESKLINE® DL5/DL6 system:

Irrespective of the load the **duty cycle 10% ~ 6 min./ hour or max. 2 min. at continuous use** stated in the data sheets, must **NOT** be exceeded as this will result in a superheating of the motor, the brake and the spindle nut. Exceeding the duty cycle will result in a dramatic reduction of the life of the system.

The DESKLINE® DL5/DL6 system range contains the following products:

- 1 control box CBD6S 200W or CBD6S 300W (SMPS - Switch Mode Power Supply)
- 1 single DL5/DL6 or 2 in parallel
- 1 exchangeable mains cable
- 1 or 2 motor cables
- 1 DP1U/DPF1M (if memory function is required) DP1C/DPT/DPF1C (if memory function and display is required) or DPF1D (if display is required).

Electrical connection of the DL5/DL6 system

The DESKLINE® DL5/DL6 system is to be connected as shown in Figure 4. Each DL5/DL6 is to be connected to the sockets on the control box by means of the motor cables, which have a 6-pin plug on each end. Finally, the main power cable is to be mounted and power switched on.



Please note that the control box must only be connected to the voltage stated on the label.

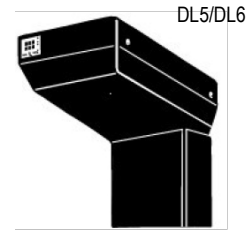

Figure 4

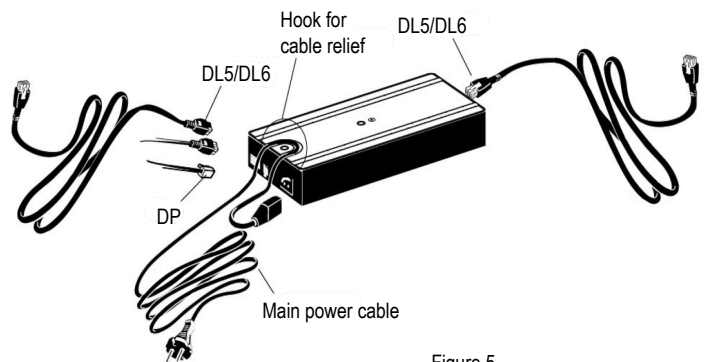

Figure 5

Anti-Collision™

The function (anti-collision) is an option for the standard CBD6S (SMPS) control box. A system with anti-collision can limit material damages on a desk if a collision with a solid object should occur.

Enabling the anti-collision

To enable the anti-collision function a little plug called a dongle must be mounted in one of the 2 control ports. The function is only active when the dongle is mounted. - If you remove the dongle again you disable the function.

Method of operation

When the DL/DB's are running, the CBD6S (SMPS) monitors the current consumption on each channel using a special algorithm. If the current consumption on one channel is increased more than a predefined slope, a collision is assumed and all channels are stopped immediately and all DL/DB's will start to run in the opposite direction (approx. 50 mm). This return drive is done automatically and continues with or without any control key pressed (for max. 2.5 sec.).

The anti-collision sensitivity is different in upward and downward direction. Upwards the force is approx. 20 kg. Downwards the load will be approx. 40 kg + the load on the DL/DB (the desk + what is on top of the desk). The 40 kg are needed to activate the anti-collision function.



Situations where the anti-collision does not work

There are situations where the anti-collision will not be activated. These situations are:

- If the collision happens during the initialisation phase
- If the collision happens within the first 1000 msec or after the control button has been released
- If the collision happens between the floor and the table and the load on the desk + the weight of the legs are lower than 40 kg
- If the collision happens over too long time, e.g. if the collision is with a soft object.

Freedom One eLift Workstation Troubleshooting Guide

Symptom	Problem	Solution	
Worksurface will not operate	Loss of power	Be sure control box is plugged into a live circuit.	
	Loose electrical connections	Make sure all electrical connections are securely plugged into the control box. See wiring diagram on p.10 for reference.	
	Object encountered under the workstation worksurface	<ol style="list-style-type: none"> 1. Raise the worksurface by pressing the "up" button. 2. Remove any items under the workstation worksurface. 3. Reset the lift mechanism (see below for procedure.) 	
	Misaligned actuators due to unbalanced loads	Solution #1	
		<ol style="list-style-type: none"> 1. Unplug, then re-plug the power cord into a wall outlet. 2. Make sure all lift mechanism wire connections are in place and secure. 3. Remove <u>anything</u> located under the workstation worksurface. 4. Press and hold the "Down" button to lower the worksurface to the lowest position until it stops moving. 5. Release the "Down" button. <p>Note: If the worksurface does not lower when doing this step, release the "Down" button, and retry steps 1-5.</p> <ol style="list-style-type: none"> 6. Release the "Down" button. The lift mechanism has now been reset and the worksurface can be adjusted normally. 	
Solution #2		<ol style="list-style-type: none"> 1. Detach <u>one</u> of the actuators from the worksurface. 2. Lower the workstation all the way down. 3. Re-attach the actuator to the worksurface. 	

WARNING

Be sure the workstation movement does not interfere with objects or people. Do not place any items under the workstation worksurface.

Note: Not designed to be permanently anchored to the floor. Optional glides are available if a stationary workstation is needed.

Warranty

WE WILL MAKE IT RIGHT FOR YOU!

Spectrum is committed to provide complete customer satisfaction. Each of our products is manufactured from the best materials available and each product is stringently monitored throughout the production process through our P.A.C.E. program (Product Assurance to meet Customer Expectations).

We expressly warrant that Spectrum products will be of good quality and workmanship and free from defect for the period set out in the warranty table below from the date of delivery. This warranty shall not apply to defects or damage resulting from misuse, abuse, neglect, improper care, modification or repair not authorized by Spectrum, or any other cause outside the control of Spectrum. Spectrum will, at its sole option, either repair or replace the defective product.

This warranty is exclusive; no other warranty, written or oral, is expressed or implied. This warranty is given by Spectrum to Buyer and to no other person or legal entity. No Spectrum dealer, distributor, agent or employee is authorized to make any modification or addition to this warranty.

NOTWITHSTANDING ANYTHING TO THE CONTRARY, SPECTRUM WILL NOT UNDER ANY CIRCUMSTANCES BE LIABLE FOR INDIRECT OR LIQUIDATED DAMAGES, INCLUDING CONSEQUENTIAL, INCIDENTAL AND SPECIAL DAMAGES. IN NO EVENT SHALL SPECTRUM'S LIABILITY, WHETHER UNDER CONTRACT OR WARRANTY, IN TORT OR OTHERWISE, EXCEED THE PURCHASE PRICE RECEIVED BY SPECTRUM FOR THE PRODUCT AT ISSUE AND "RECALL ACTION" EXPENSES. SPECTRUM SHALL NOT BE SUBJECT TO ANY OTHER OBLIGATIONS OR LIABILITIES, WHETHER ARISING OUT OF BREACH OF CONTRACT, WARRANTY, TORT (INCLUDING NEGLIGENCE AND STRICT LIABILITY) OR OTHER THEORIES OF LAW, WITH RESPECT TO PRODUCTS SOLD OR SERVICES RENDERED BY SPECTRUM, OR ANY UNDERTAKINGS, ACTS OR OMISSIONS RELATING THERETO.

Our Customer Service Department is ready to provide immediate attention to any questions, comments or concerns. They are available to answer your calls Monday through Friday from 7 am to 5 pm CST. In addition your product comments or concerns are welcome via e-mail at: spectrum@spectrumfurniture.com.

Warranty Table

Item	Warranty Period effective 1/1/2015
Adjustable Crank / Electric Desk Legs	• 1 Year
Flat Panel Desk Gas Cylinders	
Chairs <ul style="list-style-type: none"> • Adjustable Height Chair Parts – including frames, gas cylinders, wood and plastic parts, control handles, casters • Adjustable Height Chair Upholstery • In-Stock Upholstery • Graded-In Fabrics and Customer Owned Material 	<ul style="list-style-type: none"> • 7 Years • 2 Years • 2 Years • No Warranty
Height Adjustable Columns and Lifts	• 1 Year
General Use Casters	
Electrical (including timers and LINAK actuators)	• 2 Years
Keyboard / Mouse Trays	• 1 Year
Flat Panel Monitor Arms <ul style="list-style-type: none"> • Flat Panel Monitor Arm – General Parts • Flat Panel Monitor Arm – Gas Cylinders 	<ul style="list-style-type: none"> • 5 Years • 2 Years
Desks and Lecterns <ul style="list-style-type: none"> • Computer Desk Chassis • Cart Chassis • Lectern Chassis 	• 10 Years

