

Assembly Instructions

⚠ Important ⚠

Before you begin, read and comply with all safety and operating instructions, and ensure all parts and correct quantities are included.

Any parts damaged during shipment must be reported within 5 days of receipt. To report information regarding missing parts or damage, to purchase parts or accessories, or if you have any questions, please contact us.

www.spectrumfurniture.com
 800-235-1262, 715-723-6750

Thank you for purchasing Spectrum products!

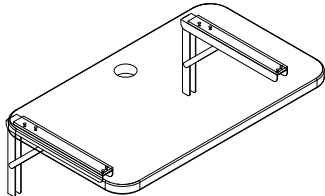

(1) 0120069
 Flip-up shelf assembly



(1) 039622
 2" Grommet

For metal side panels

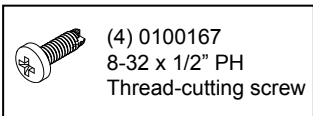

(4) 0100167
 8-32 x 1/2" PH
 Thread-cutting screw

For laminate side panels

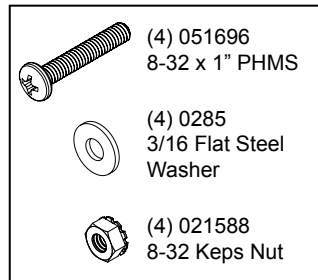

(4) 051696
 8-32 x 1" PHMS

(4) 0285
 3/16 Flat Steel
 Washer

(4) 021588
 8-32 Keps Nut

1. Before You Begin

Determine:

- Side of the lectern the shelf will be installed. (Left or right-side)
- Upper or lower shelf position
- Type of side panels your lectern has (metal or laminate) **Figure 1A**

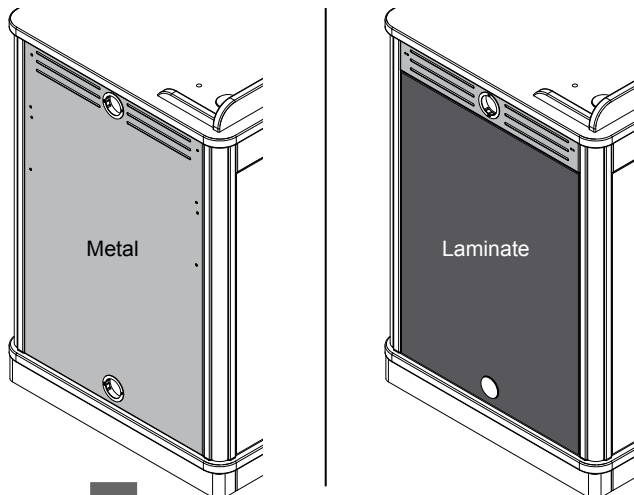
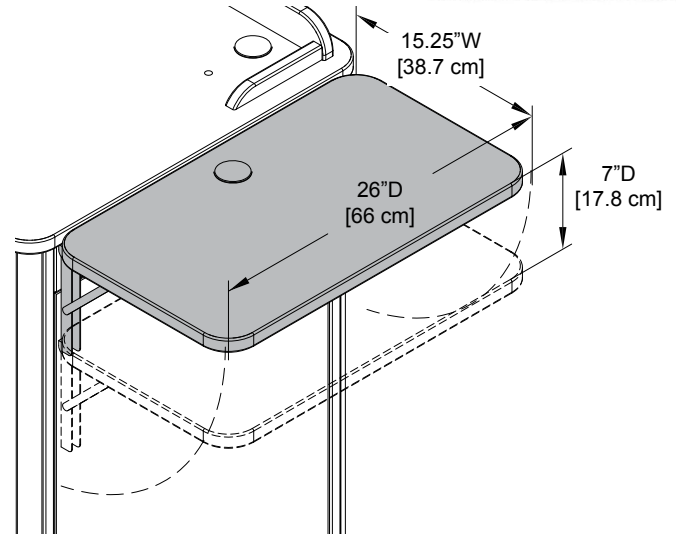

Figure 1A

Proceed to Step 2



**Flip-up Shelf
 for Link Lectern™
 55385**

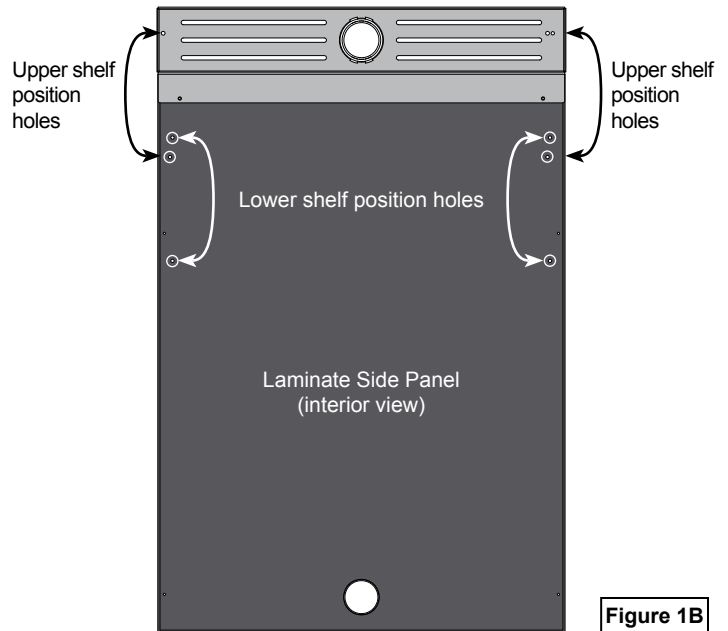
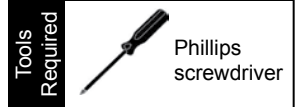

Figure 1B

Attaching to Laminate Side Panels:

1. Open the lectern door and remove the rack cube (if equipped).
2. From inside the lectern, use a drill with a 3/16" drill bit and slowly drill out the corresponding pre-drilled pilot holes located on the laminate side panel. **Figure 1B**. Masking tape can be used on the exterior to minimize chip-out.



Note: There are (2) holes needed for the upper position, and (4) needed for the lower position. Drill with 3/16" drill bit

2. Attach Shelf Brackets to Lectern

1. Remove the instructor-side door and audience-side panel.
2. Extend and lock each folding shelf bracket into the horizontal position. **Figure 2A.**
3. Align and attach each bracket to the side of the lectern using:

Metal side panels	Laminate side panels
Figure 2A	Figure 2B (a 2nd person to assist may be required)
(4) 8-32 x 1/2" PH Thread-cutting screws	(4) 8-32 x 1" PHMS (4) 3/16" Flat steel washers (4) 8-32 Keps nuts

4. Tighten all screws securely.
5. Install 2" grommet in shelf.

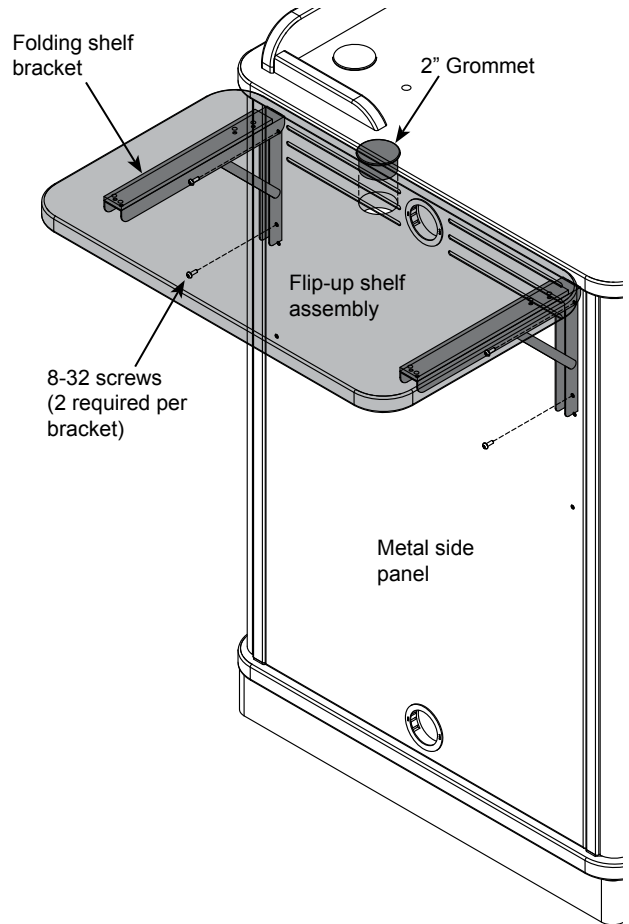

Figure 2A

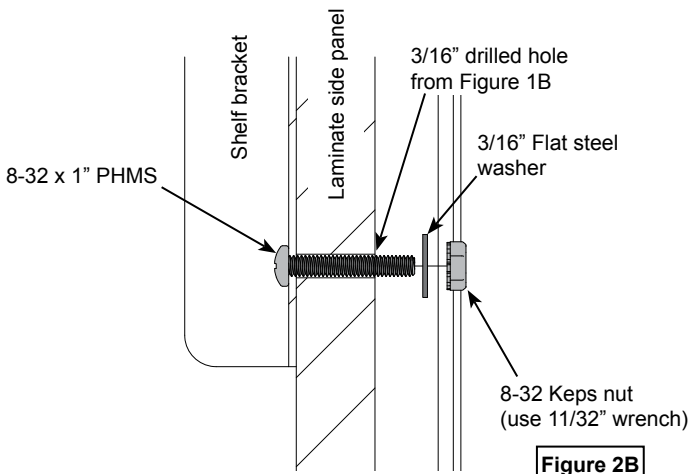

Figure 2B

3. Operation

The shelf will automatically lock into place when lifted into the horizontal position with the levers released. **Figure 3.** To lower or flip-up the shelf, press and hold the levers under each folding shelf bracket at the same time while slowly lowering or raising the shelf. Do not exceed a maximum of 35 lb of weight on the shelf. Do not move the lectern while the shelf is in the horizontal position.

Note: Power and communication wiring for document cameras, laptop computers, and / or projectors placed on the flip-up shelf should be routed on top of the audience-side of the shelf. Use of the shelf grommet hole for wiring will result in pinching of the cords when the shelf is folded.



CAUTION

Keep clear of pinch points during shelf movement.
Do not exceed 35 lbs [15.9 kg] of weight on shelf.

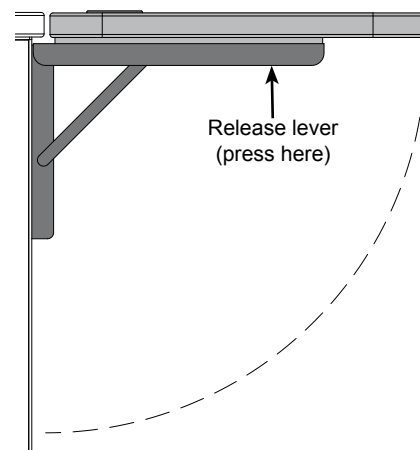

Figure 3