

Assembly Instructions



Important

Before you begin, read and comply with all safety and operating instructions, and ensure all parts and correct quantities are included.

Any parts damaged during shipment must be reported within 5 days of receipt. To report information regarding missing parts or damage, to purchase parts or accessories, or if you have any questions, please contact us.

www.spectrumfurniture.com
800-235-1262, 715-723-6750

Thank you for purchasing Spectrum products!

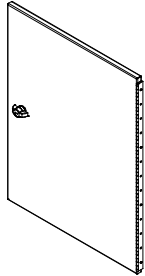

(1) 0109616
29" Solid
locking door



(5) 0100167
8-32 x 1/2" PH
Thread-cutting screw



(2) 037542
#8 x 5/8" PHSM
screw

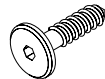

(2) 0102297
7mm x 30mm JC
Wood screws



(2) 026296
Recessed bumper
with washer



(1) 041943
1/4-20 Locknut



(2) 0107139
Offset door stop



(1) 026059
1/4" Washer



(1) 025039
4mm Hex wrench



(1) 025069
Glide wrench

Note: The 55405 locking door can be used on 36"H or 42"H Inspiration lectern versions.

- The 42"H lectern is commonly equipped with the door and keyboard tray options.
- The 36"H lectern can be equipped with the door or keyboard tray. Not both at the same time.
- If the door is used on a 42"H lectern without the optional keyboard tray, Spectrum recommends installing a 4RU rack-mount blank above the door to maintain security.

1. Install door to lectern

1. Align and attach the door hinge to the right side panel mounting holes with (5) 8-32 x 1/2" PH thread-cutting screws. **Figure 1.**
2. Tighten screws securely, but do not overtighten.

Note: If you are using an electric drill driver, be careful not to overtighten the screws. Use a low torque-setting to prevent damage to the threads.

8-32 x 1/2" thread-cutting screws
(5 required)

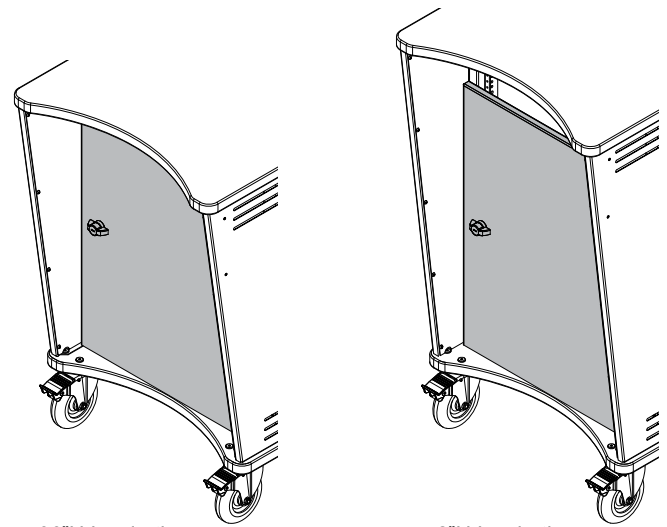

36"H Inspiration
Lectern

42"H Inspiration
Lectern

Instructor-side locking door for Inspiration Lectern 55405

Tools Required



Phillips
screwdriver

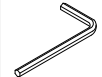

4mm Hex wrench
(included)

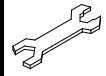

Glide wrench
(included)
or 7/16" wrench
(for 42"H lectern)

Inspiration lectern
right side panel

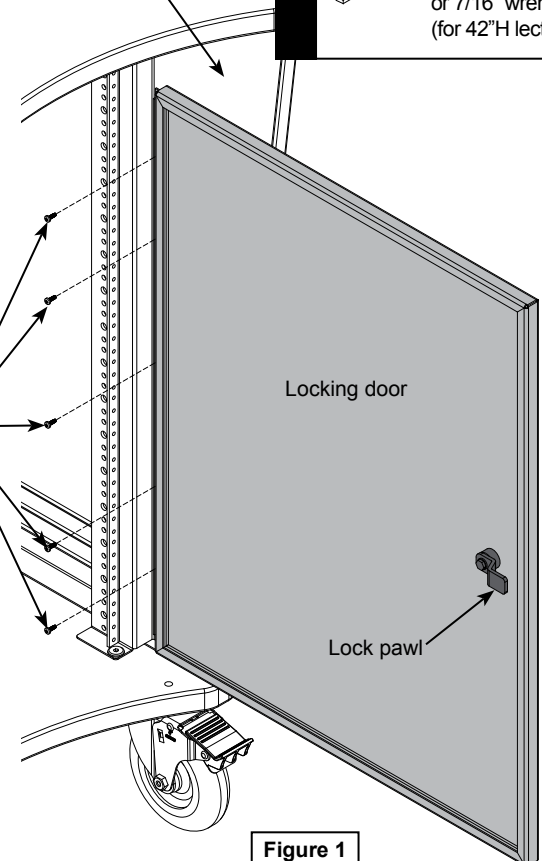

Locking door

Lock pawl

Figure 1

2. Install recessed bumpers

1. With the door closed, remove the (2) existing #8 x 5/8" PHM screws from the right side panel. See **Figure 2A** for 36"H lecterns, see **Figure 2B** for 42"H lecterns.
2. Install a recessed bumper into each open hole location with a #8 x 5/8" PHM screw.
3. Tighten screws securely, but do not overtighten.



Note: On **36"H lecterns**, the upper bumper will be installed in the top hole.

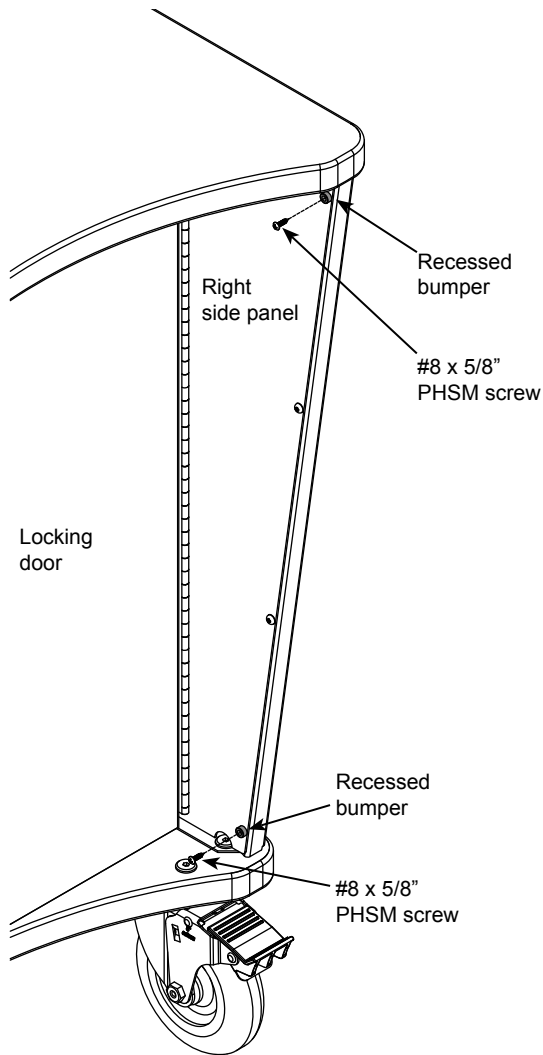

Figure 2A

Note: On **42"H lecterns**, the upper bumper will be installed in the 2nd hole from the top.

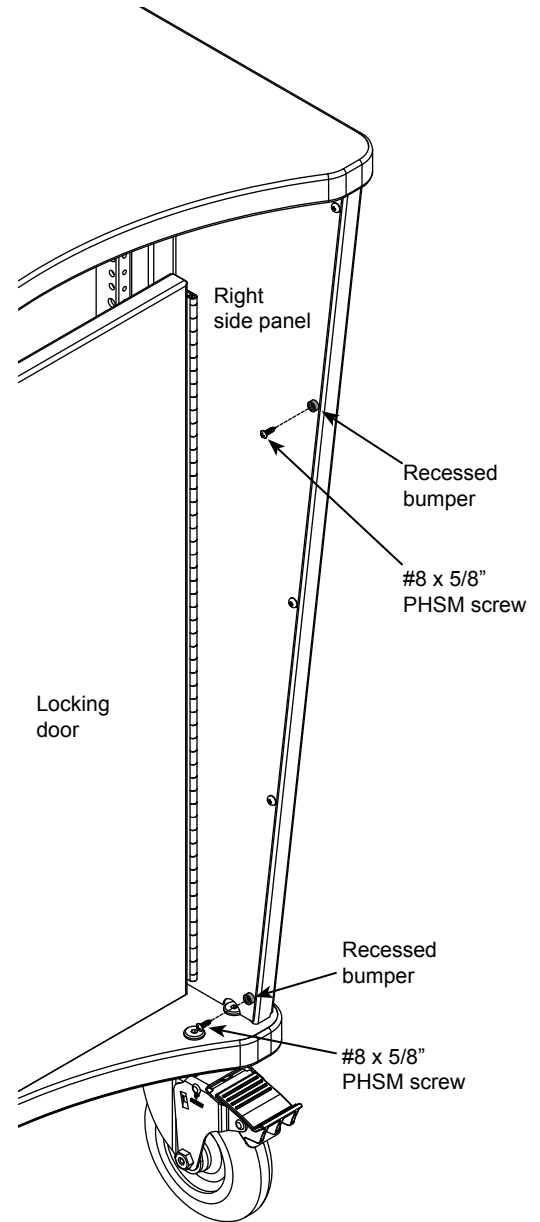

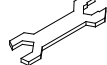

Figure 2B

3. Install door stops

1. On **36"H Inspiration lecterns**, open the door and install the upper door stop to the worksurface, and the lower door stop to the base panel—each with a 7mm x 30mm JC wood screw. **Figure 3A.**

Note: On the upper door stop, use the 1/4" washer between the worksurface and door stop.

Tools Required	 4mm Hex wrench (included)	 Glide wrench (included) or 7/16" wrench (for 42"H lectern)

1. On **42"H Inspiration lecterns**, open the door and install the upper door stop through the notch in the left side panel with a 1/4" washer and 1/4-20 locknut. **Figure 3B.**
2. Install the lower door stop to the base panel with a 7mm x 30mm JC wood screw.

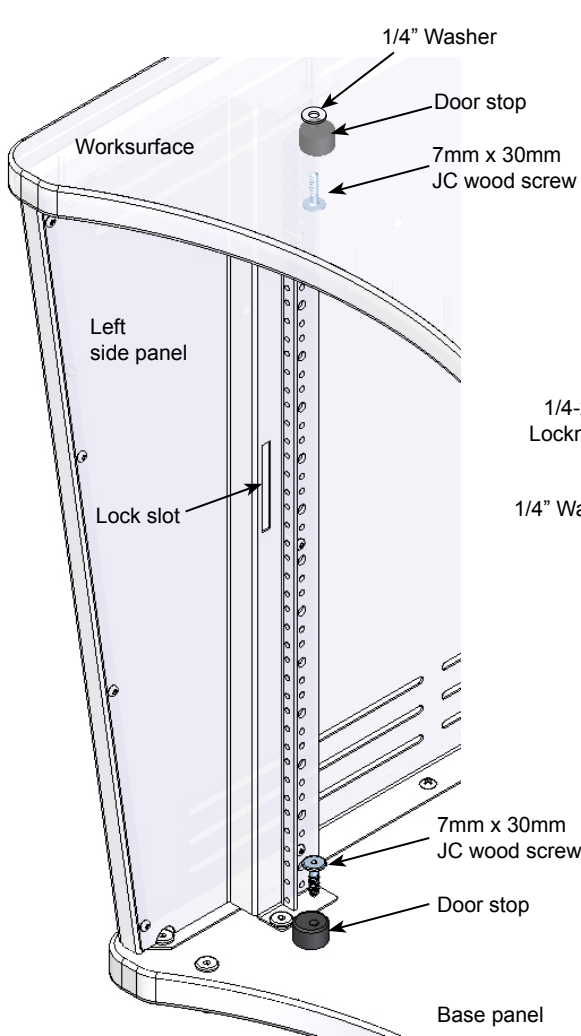

Figure 3A

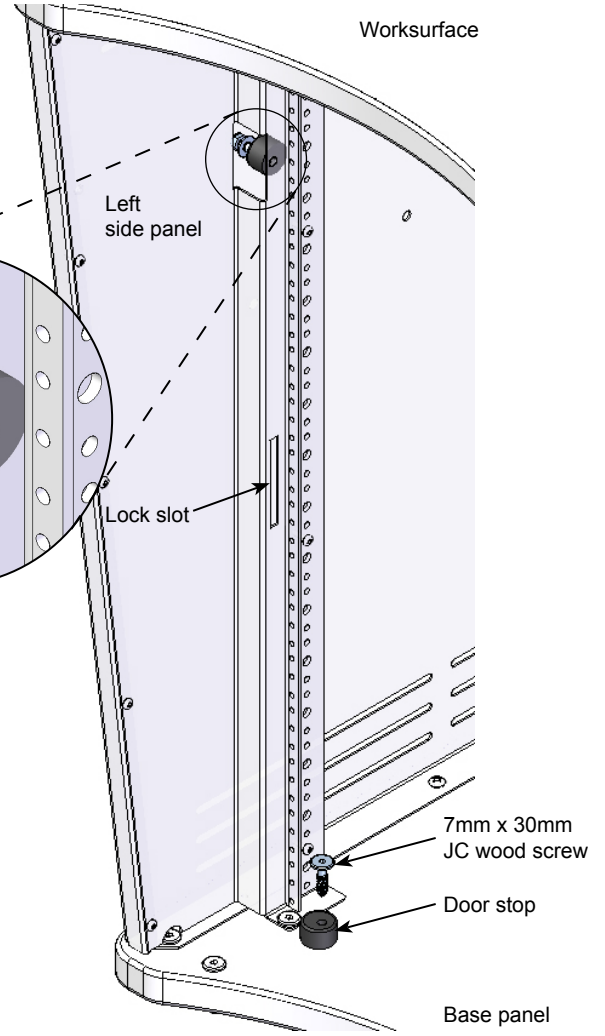



Figure 3B

4. Door stop adjustment

1. The door stop can be rotated slightly to adjust the closed position of the doors. To rotate, loosen the JC screw (or upper door stop locknut on 42"H lecterns) slightly with a 4mm hex wrench. **Figure 4.**
2. Rotate the door stop until the door contacts the upper and lower bumpers at the same time when closed. Also be sure the lock pawl on the door will align and engage with the lock slot in the left side panel.
3. Re-tighten the JC bolt (or locknut) securely.

Tools Required	 4mm Hex wrench (included)

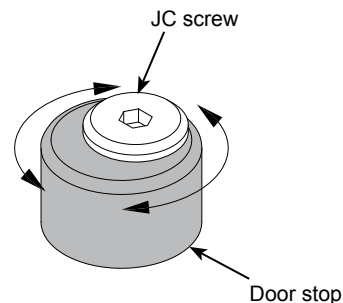

Figure 4