

Technical Specifications

55472

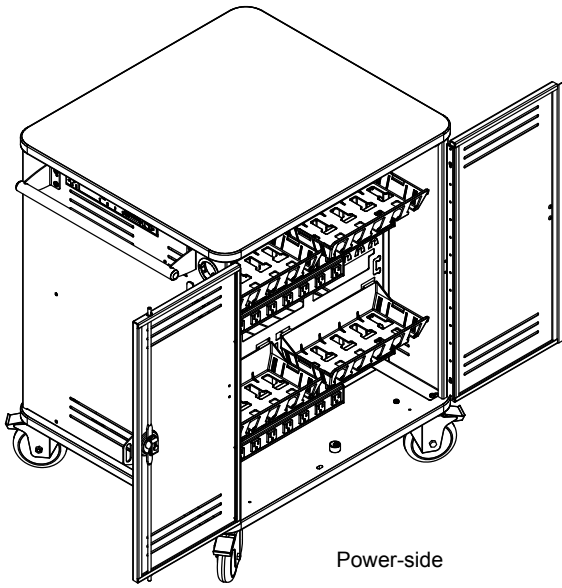

Power-side

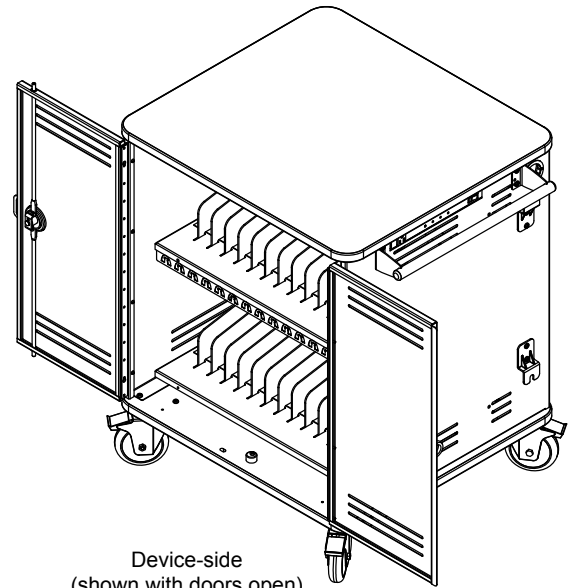

Device-side
(shown with doors open)

Use the Pro32 Cart to store, transport, and charge up to 32 notebooks or laptops. A current-sensing charger provides adaptive switching. Padded shelves and flexible dividers protect the notebooks. The overhead wire management aids the wiring integration and allows the charging plugs to hang in front of each laptop. The cart's compact footprint and handle provide easy mobility. The Pro32 Cart is made with heavy-gauge steel for security and powder-coated for a durable, long-lasting finish. A dual-bolt lock with hasp on the doors increase security of the notebooks.



Features and Benefits

- Stores, charges, and transports up to 32 of the largest notebooks (laptops) commonly used in education
- 1.625"W x 17.375"D x 12.4375"H storage bay
- Small cart footprint (30.75"W x 28"D) saves valuable space
- Durable ABS plastic dividers and shelf padding protect notebooks from scratching (dividers are removable to provide storage space for thicker devices)
- Dual doors provide easy access while reducing space necessary for swing radius
- Double bolt keyed locks and heavy-gauge steel doors provide security
- Hasp locks provide an additional level of security and the ability to use your padlocks of choice (not included)
- Notebooks and students are separated from all line voltage
- Superior, all-metal overhead cord management system keeps charge cords organized above each storage bay
- Four inboard locking casters provide easy rolling, and quiet transport (5" balloon wheel, 4" balloon wheel options available)
- One all steel handle provides control and maneuverability
- Worksurface and base panel vinyl edging protects walls and furniture
- Cart ships fully-assembled with handle for quick, simple integration and deployment
- Durable powder coated steel chassis provides a long-lasting finish
- Scratch and impact-resistant high-pressure laminate top provides a durable, useful worksurface for instructors
- ETL recognized (certified to UL 60950-1) in the US and Canada for the cart and electrical system
- Warranted to be free of all defects in materials and workmanship for 10 years, electrical system 2 years
- Designed and assembled in Chippewa Falls, WI, USA

Available with:

- PowerProdigy™ charger that senses current from both power units and distributes power (up to 10A) to the least-charged devices first (where charging is needed most) ***For most power adapters up to 65W**
- Basic Timer provides cycling power to both power units (non current-sensing) ***For most power adapters up to 65W**
- Four horizontally adjustable, 8-outlet, (125V~/12A, 60Hz) universal power units work with both inline, and wall adapters
- External power switch provides easy-access for safe power connection / disconnection
- 2 aux outlets (always on) for teacher laptop, Wi-Fi access point, or other accessory (1 external, 1 internal)
- Large, removable QuickBrick™ wiring trays with retaining straps for charge adapters allow wiring to be completed outside the cart at the comfort of a workstation or desk to provide quick and easy integration
- Ventilated doors and side panels keep notebooks and chargers cool, preventing overheating, and extending device life
- Replaceable, IEC quick-release 8' nominal 14 AWG, 3-wire power cord and external cord wrap brackets provide easy power access

This cart is designed to hold up to 32 notebooks or laptops.

- 55472-AAD** - with 4" Balloon Wheels, PowerProdigy™ charger
- 55472-ABD** - with 5" Balloon Wheels, PowerProdigy™ charger
- 55472-AAL** - with 4" Balloon Wheels, Basic Timer
- 55472-ABL** - with 5" Balloon Wheels, Basic Timer

Color Options

Laminate:  White Fiesta

Metal:  Warm Gray

Construction

- The worksurface and base panel is constructed from 1" NAF (No Added Formaldehyde) composite board with .030" high-pressure laminate on one face, and a balancing phenolic backer on the opposing face
- Worksurface and base panel edges are covered with 3mm vinyl edgeband
- 16-gauge side panels, shelves, and doors
- All metal components are finished with a scratch-resistant powder coat epoxy
- This cart is factory-assembled, packaged, and shipped on its own skid

Specifications

Capacity	32 Notebooks or Laptops	
Storage bays (nominal)	1.625"W [4.13 cm] x 17.375"D [44.1 cm] x 12.4375"H [31.6 cm]	
Electrical	<ul style="list-style-type: none"> • (4) 8-outlet power units (outlets rotated 90°) • 125V~/12A, 60Hz • 15-amp breaker • IEC quick-release (replaceable) 15' nominal, 14 AWG, 3-wire power cord 	<ul style="list-style-type: none"> • Locking power-side door isolates and separates electrical line voltage from students • ETL recognized (certified to 60950-1)
Charging options	(See p.4 for specs)	
Wheels	5" Balloon Wheels - Weight capacity 300 lb [136 kg] each 4" Balloon Wheels (total locking) - Weight capacity 250 lb [114 kg] each	
Certifications / Compliance	<ul style="list-style-type: none"> • ETL recognized • SCS Indoor Advantage Certified 	<ul style="list-style-type: none"> • Meets or exceeds applicable ANSI-BIFMA test standards
Unit weight (nominal)	208 lb [94.4 kg]	
Shipping weight (nominal)	240 lb [108.9 kg]	

Specifications subject to change without notice

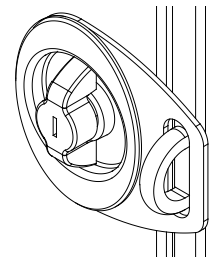
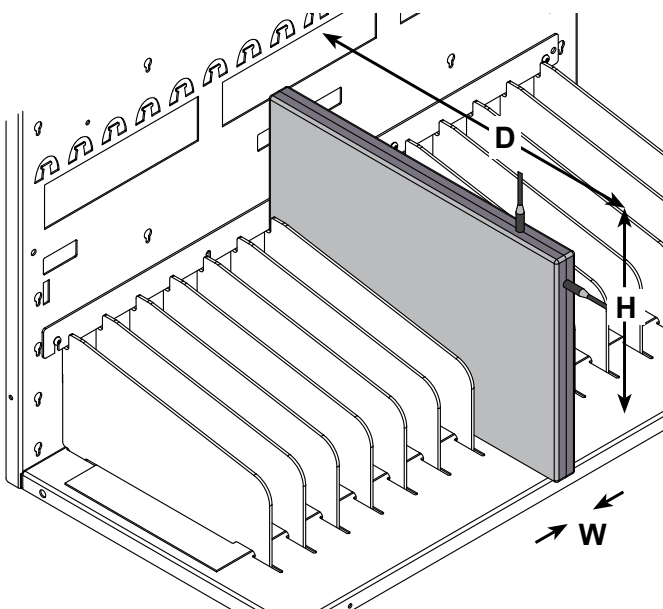

Double-bolt lock with padlock hasp (on both doors)
(padlocks not included)

Devices must be placed in the bays with the charge plug on one of the two exposed edges shown.

ORDER CODE A = 4" Balloon Wheel

ORDER CODE B = 5" Balloon Wheel

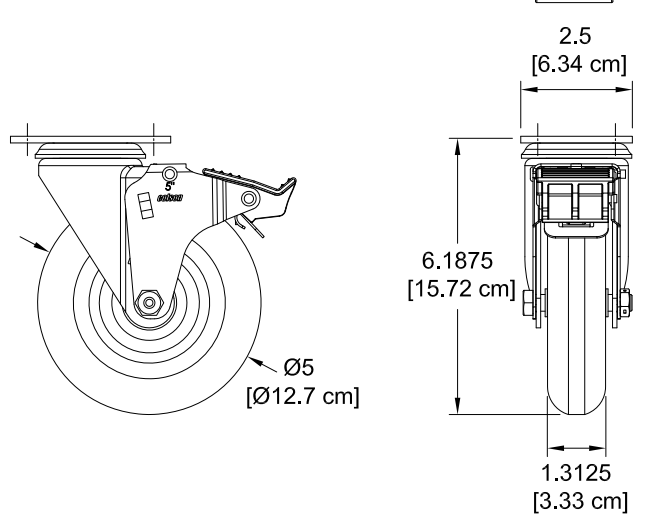
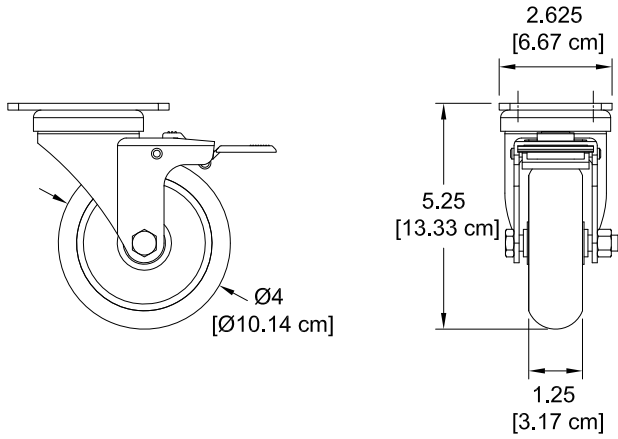
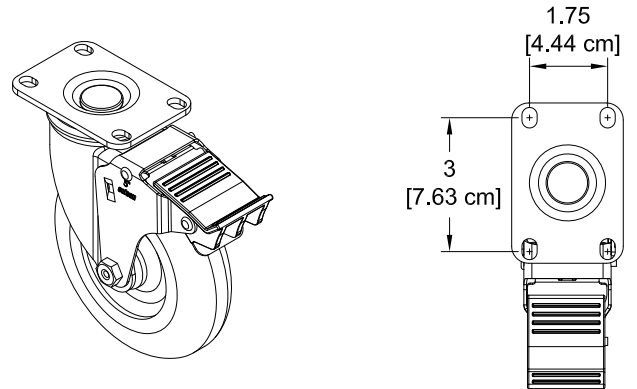
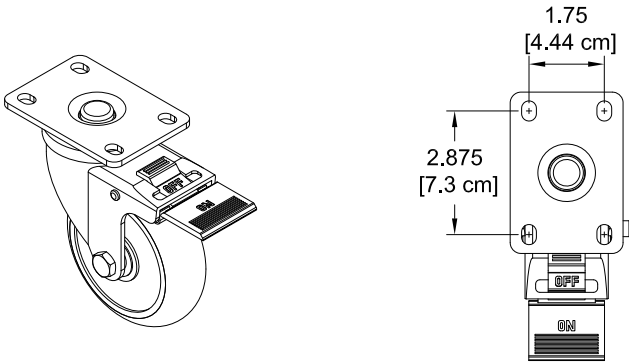

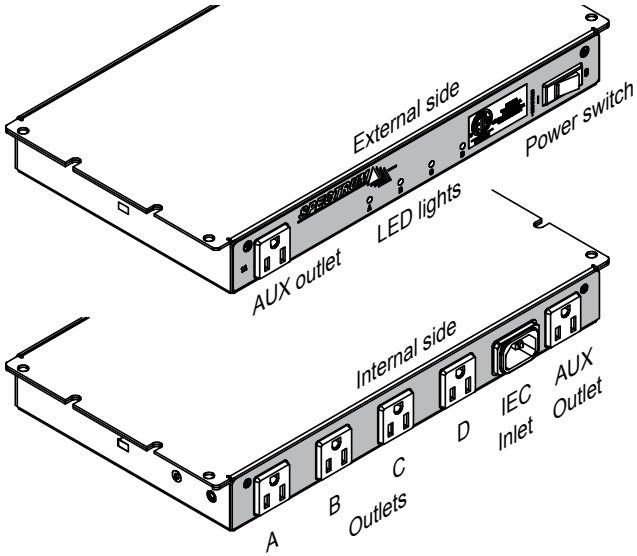

PowerProdigy™ Charger (D)

Use with higher amp-draw devices. On the Pro32, the PowerProdigy™ Charger can be used with **most power adapters up to 65W**.

- Smart charging senses current and distributes power to the power units requiring it most
- Four green LED lights indicate charging activity status of each power unit
- Four timed power unit-dedicated outlets (labeled A, B, C, D) controlled by logic board
- Two auxiliary outlets (1 external, 1 internal)
- ETL recognized (certified to 60950-1)

Input:	125V~/12A, 60Hz
Breaker:	15A, 250 VAC
Cycling interval:	15 minutes
Cycling outlets:	4 timed (A, B, C, D) up to 10A
Auxiliary outlets:	1A each (controlled by main power switch)
Power Cord:	IEC quick-release (replaceable) 8' nominal, 14 AWG, 3-wire
Power switch:	15A (externally accessible)

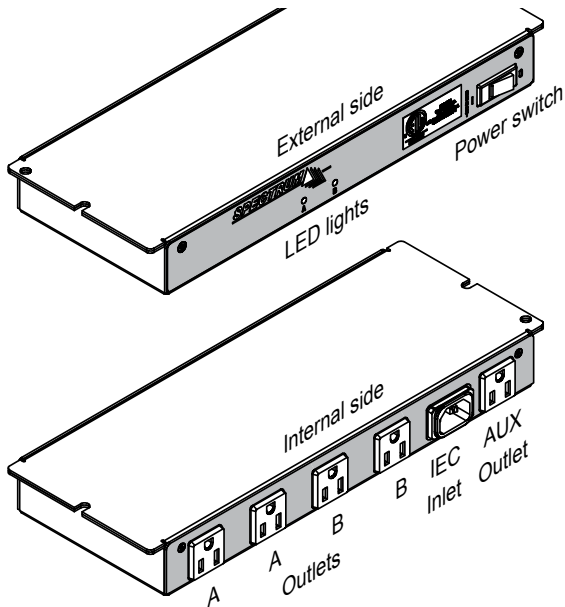

Basic Timer (L)

The Basic Timer charges one half of the devices for 15 minutes, then charges the second half of the devices for another 15 minutes. This cycling occurs automatically and is not adjustable. On a fully-loaded Pro32, the Basic Timer can be used with **most power adapters up to 65W**.

- Two timed power-unit dedicated outlets (labeled A, B) (up to 10A power output)
- Two green LED lights indicate charging activity status
- One auxiliary outlet (external)
- ETL recognized (certified to 60950-1)

Input:	125V~/12A, 60Hz
Breaker:	15A, 250 VAC
Cycling interval:	15 minutes
Cycling outlets:	4 timed (A, B) up to 10A
Auxiliary outlet:	1A (controlled by main power switch)
Power Cord:	IEC quick-release (replaceable) 8' nominal, 14 AWG, 3-wire
Power switch:	15A (externally accessible)

Pro32 Notebook Cart
 (shown with 5" balloon wheels)

External power switch,
 LED indicators, and
 AUX outlet

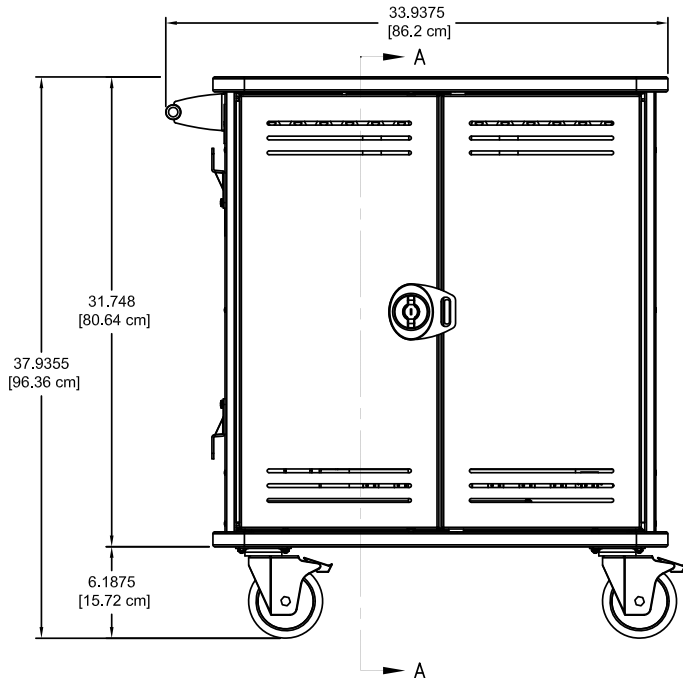
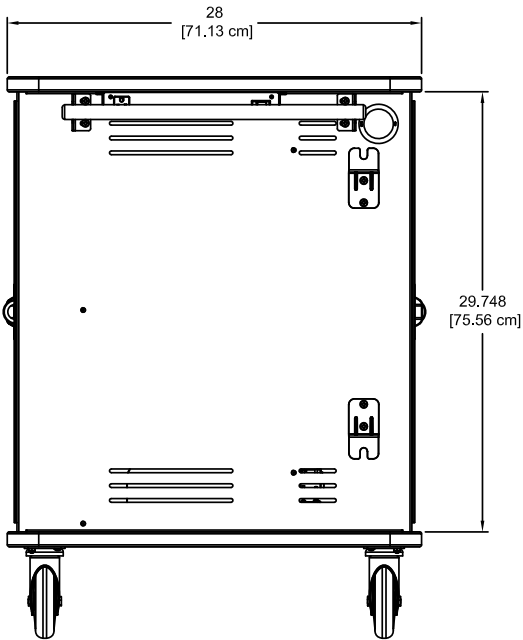
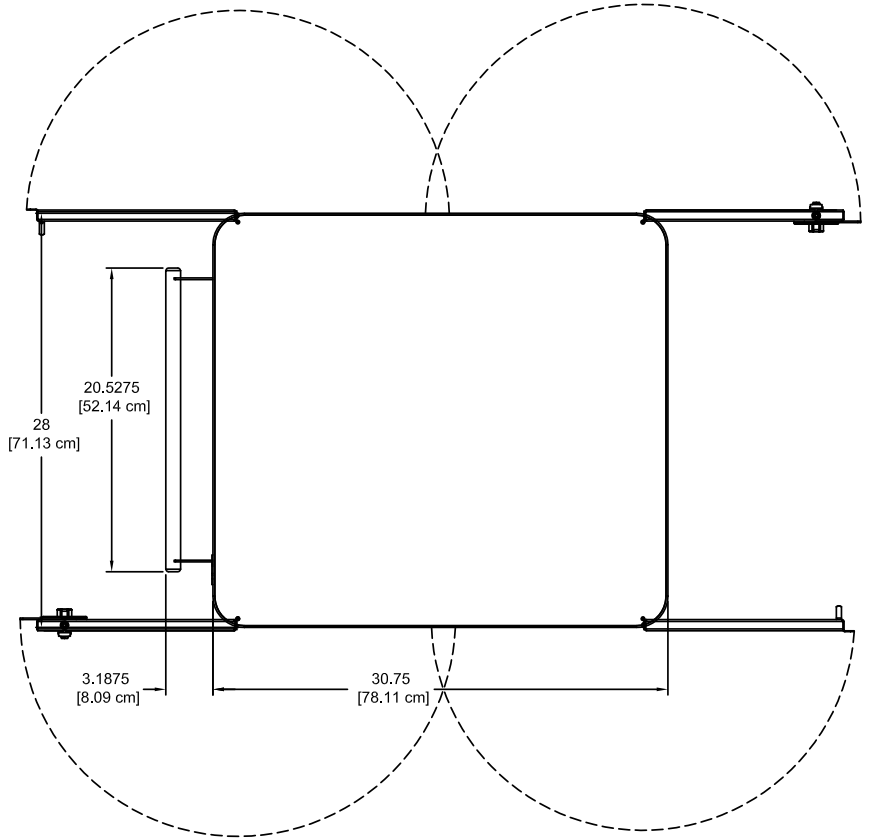
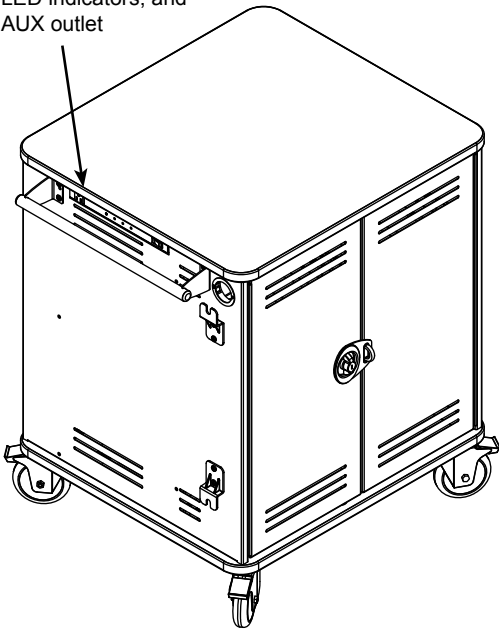

Section view A-A

Power-side

Device-side

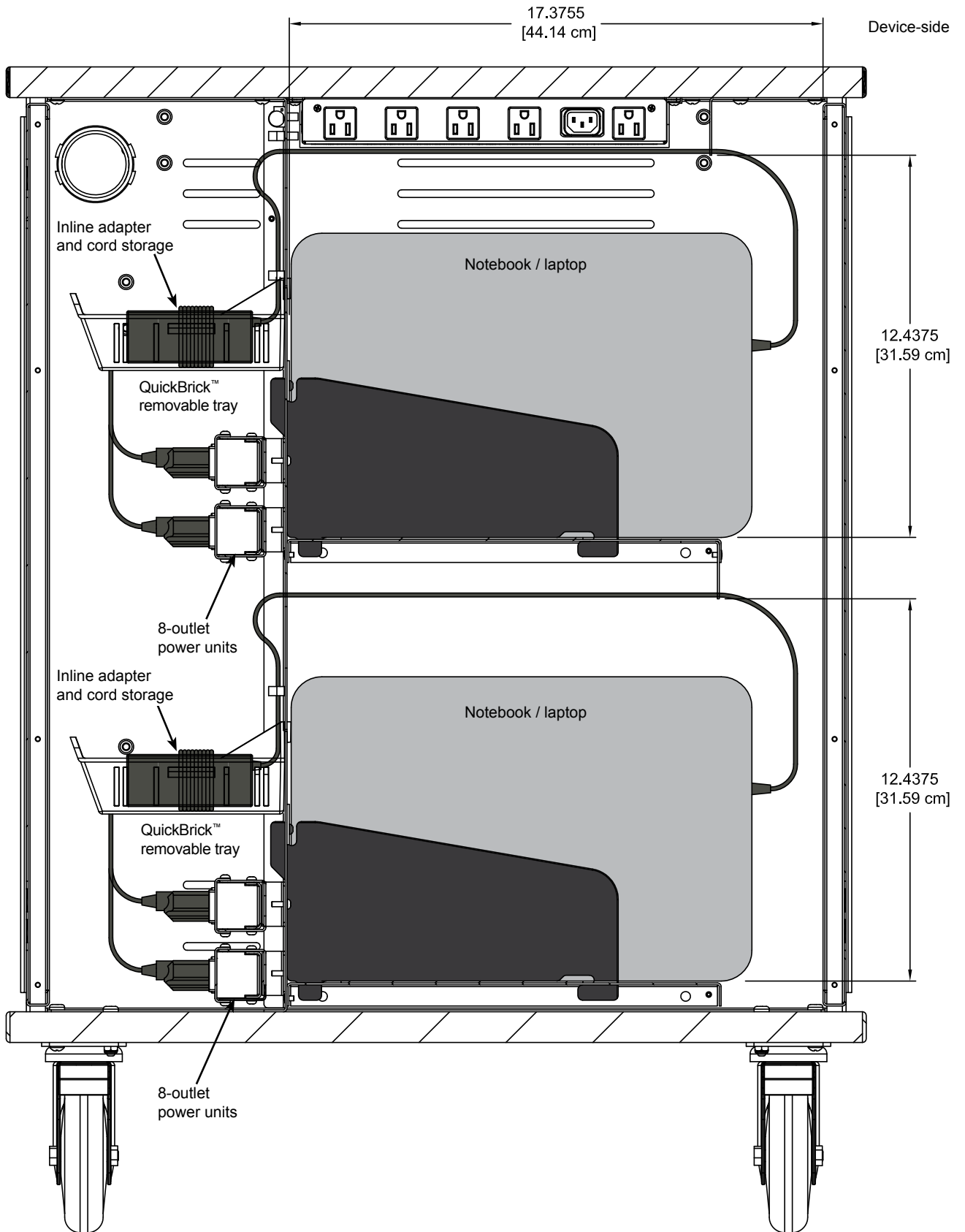

Device-side view wiring diagram
(shown without doors)

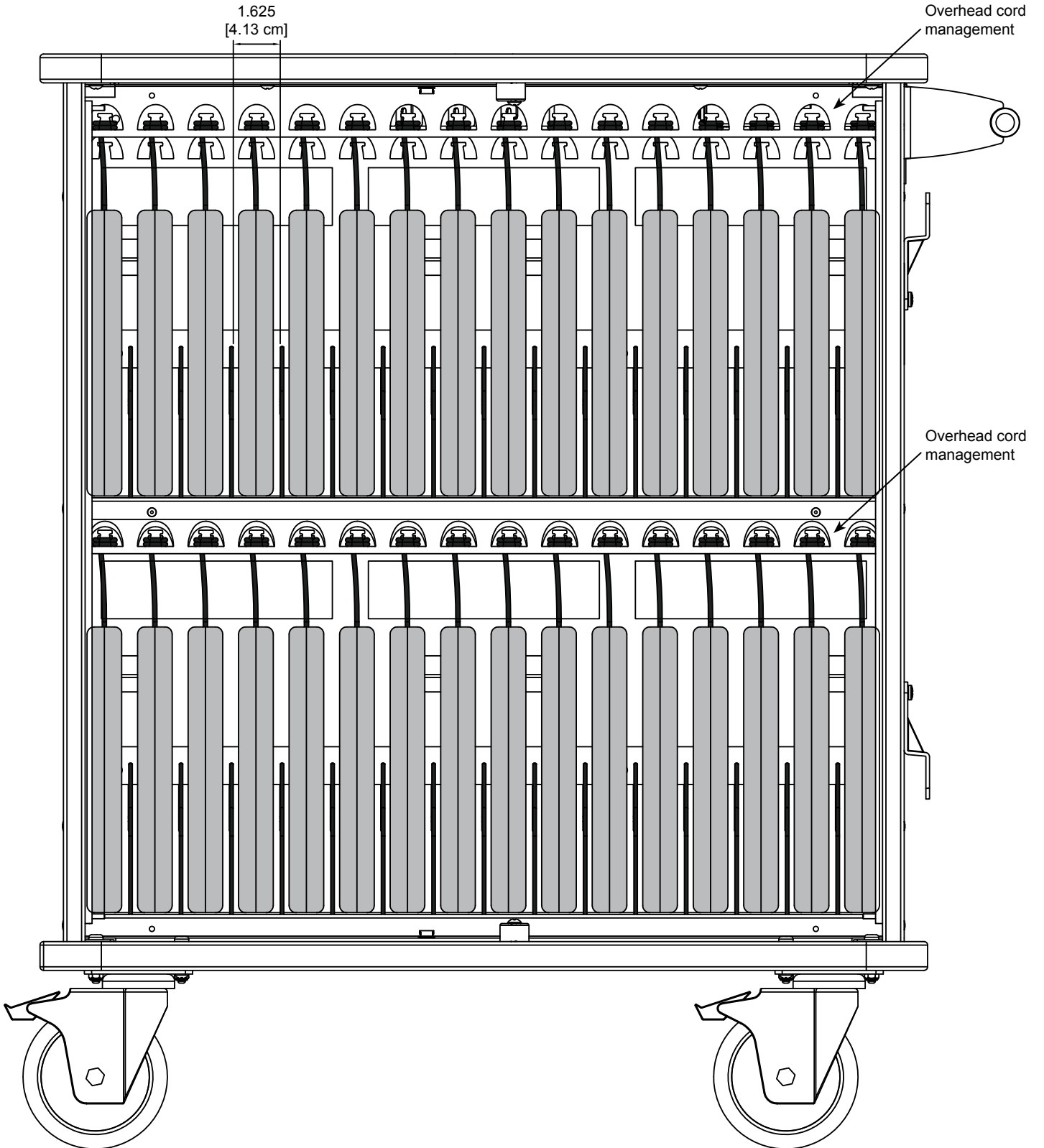

Power-side wiring diagram
and power unit adjustability
(shown without doors)

8' nominal [1m] 14 AWG,
3-wire IEC power cord
(to wall outlet)

59" nominal [1.5m] 14 AWG,
3-wire IEC power cord on
each lower power unit
(to PowerProdigy™ charger)

39" nominal [1m] 14 AWG,
3-wire IEC power cord on
each upper power unit
(to PowerProdigy™ charger)

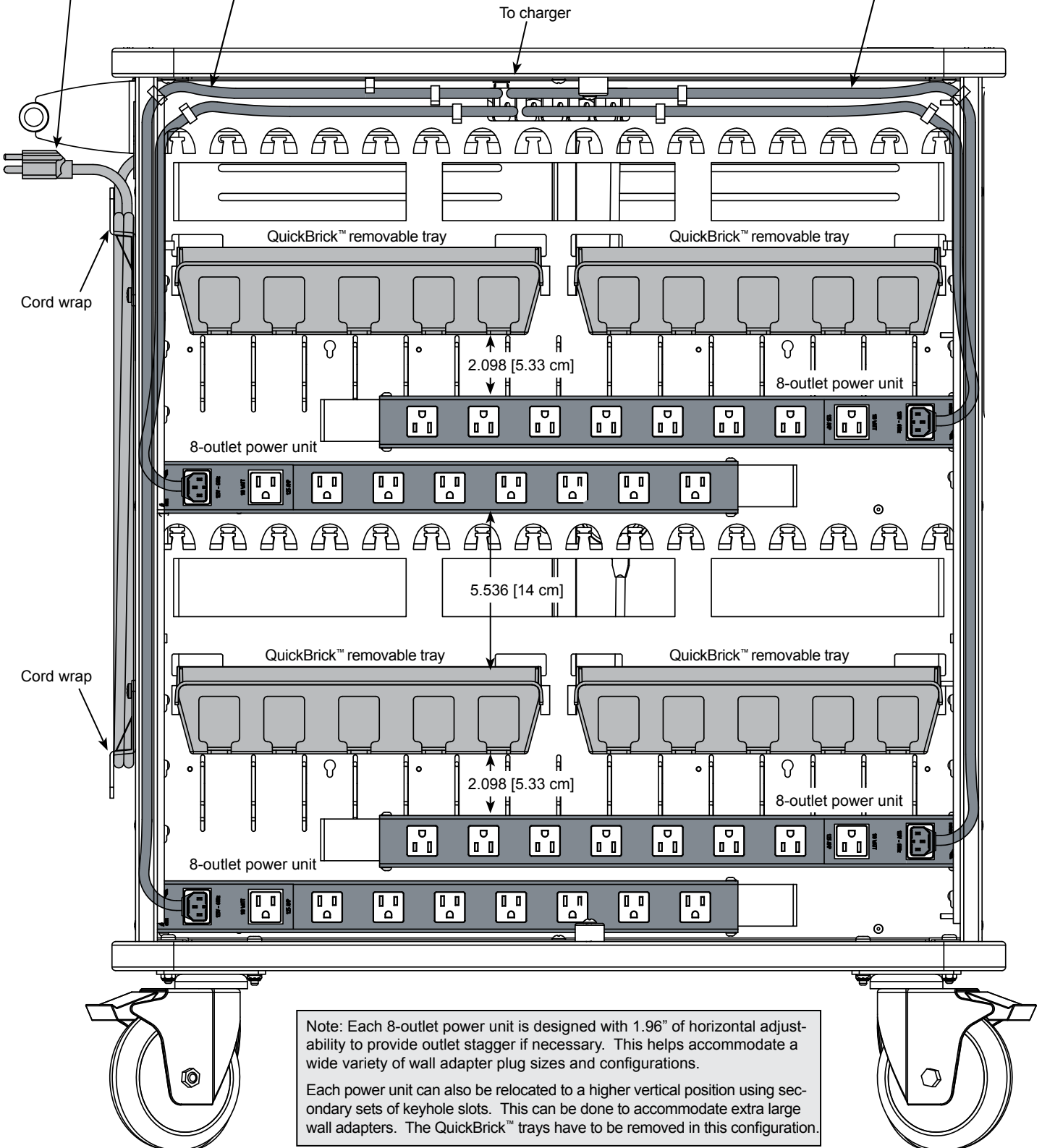

Note: Each 8-outlet power unit is designed with 1.96" of horizontal adjustability to provide outlet stagger if necessary. This helps accommodate a wide variety of wall adapter plug sizes and configurations.

Each power unit can also be relocated to a higher vertical position using secondary sets of keyhole slots. This can be done to accommodate extra large wall adapters. The QuickBrick™ trays have to be removed in this configuration.

Power unit adjustability

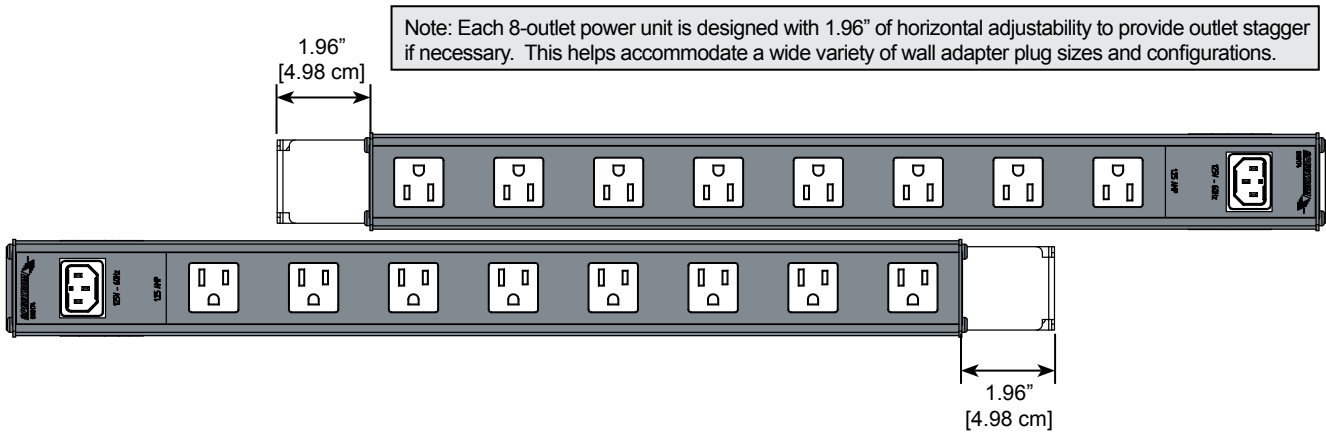

Nominal outlet spacing on each 8-outlet power unit

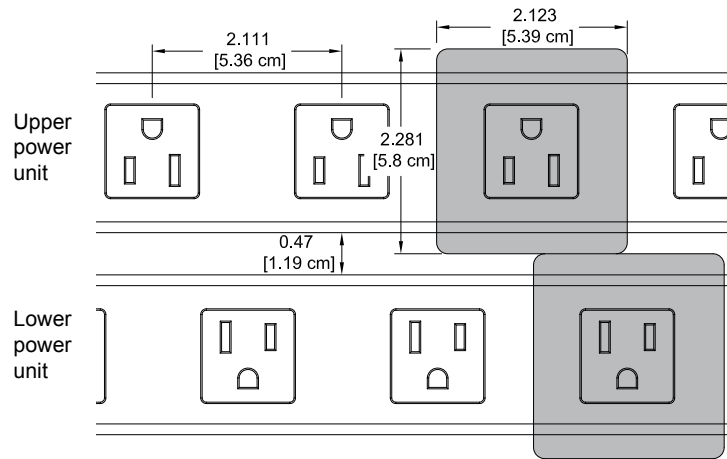

(See p.7 for spacing above and below outlets)

Power unit vertical adjustability
(shown without door)

Note: 4 sets of keyhole slots provide the ability to vertically relocate each 8-outlet power unit. This can be done to provide clearance for extra large wall adapters. Loosening two screws on each power unit allows easy adjustment. The QuickBrick™ trays are not needed and have to be removed in this configuration.

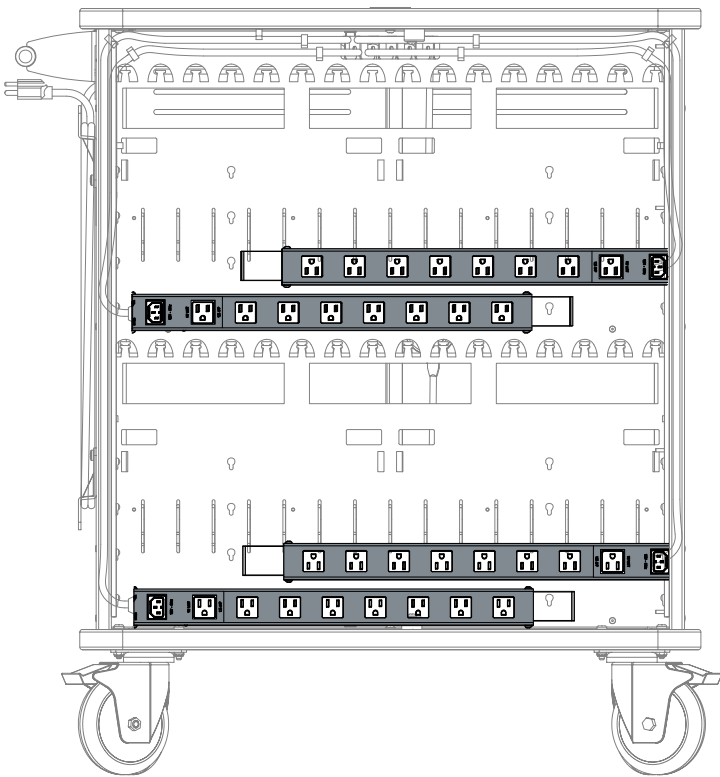
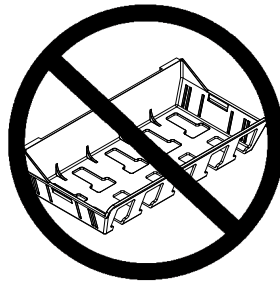
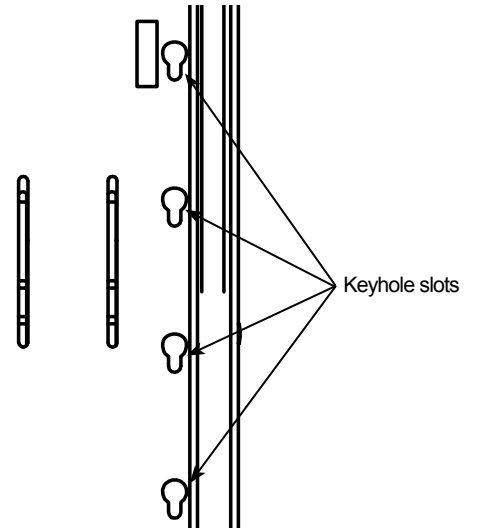

Factory-installed position

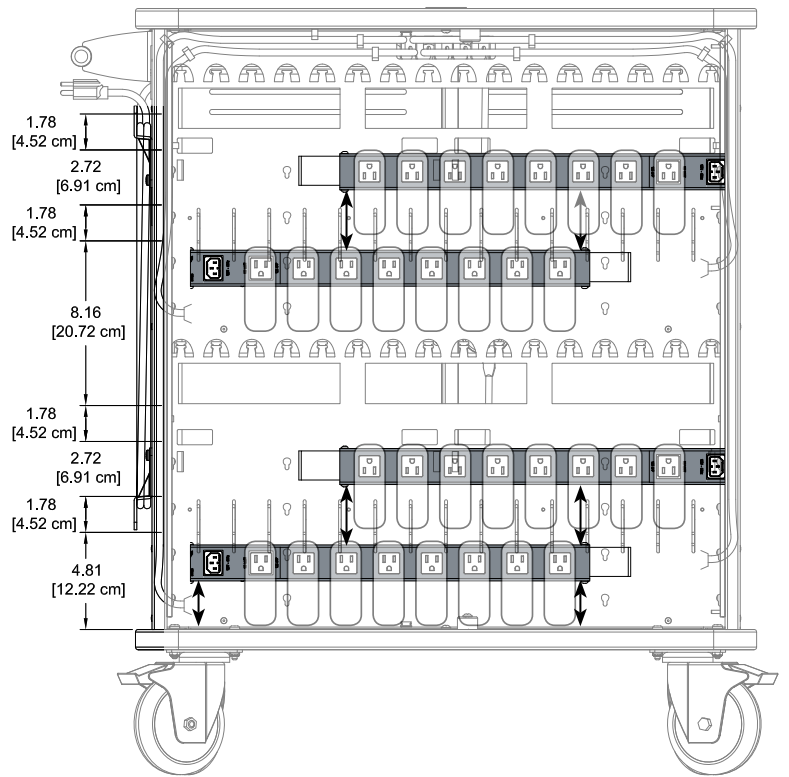

Typical spaced positions
for large wall adapters

Note: Cart includes four QuickBrick™ removable trays with a Velcro® retaining straps for charge adapters to provide fast and easy wiring for quick deployment.

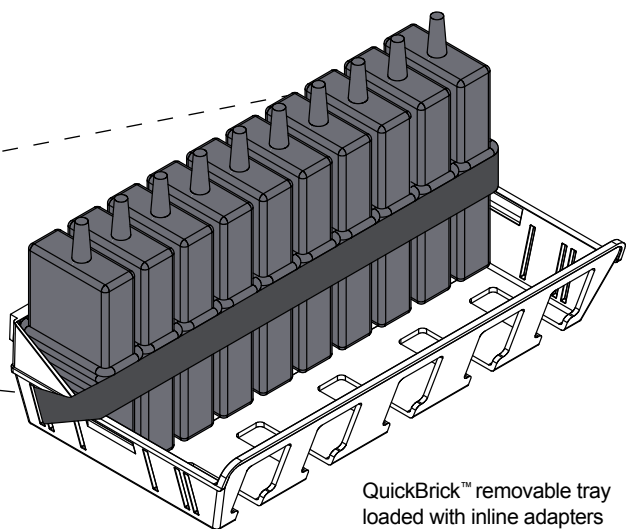
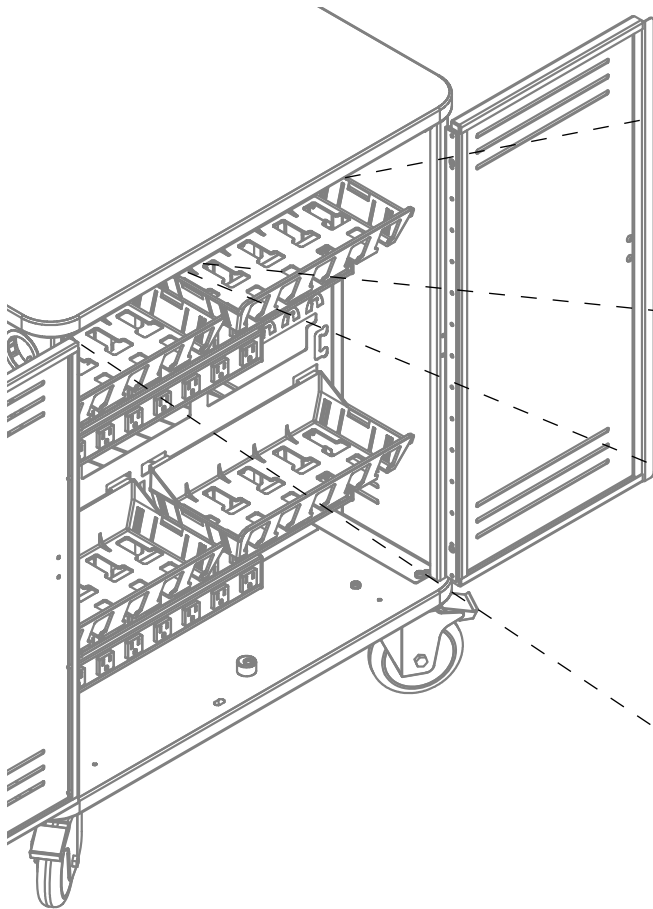

QuickBrick™ removable tray loaded with inline adapters in vertical position

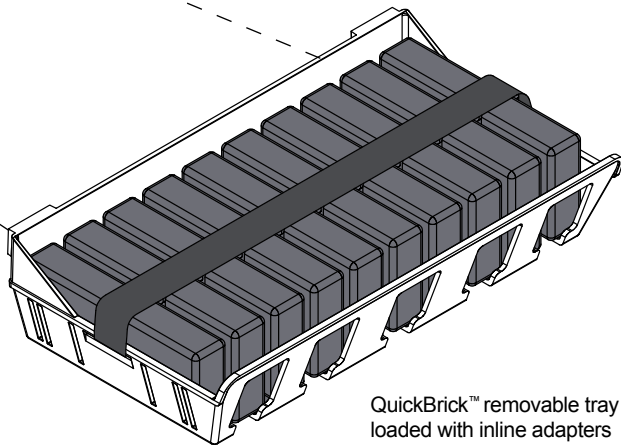

QuickBrick™ removable tray loaded with inline adapters in horizontal position

Accessories

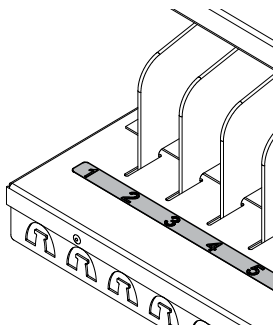

Slot labels for Pro32 - 55477

- Black numbers on transparent adhesive backer
- 1-16 label, 17-32 label



Hook-and-loop Strap Kit - 95004

- (16) .75" [1.91 cm] x 12" [30.48 cm],
- and (32) .75" [1.91 cm] x 5" [12.7 cm]

See spectrumfurniture.com for the latest accessories and detailed warranty information.

Warranty

WE WILL MAKE IT RIGHT FOR YOU!

Spectrum is committed to provide complete customer satisfaction. Each of our products is manufactured from the best materials available and each product is stringently monitored throughout the production process through our P.A.C.E. program (Product Assurance to meet Customer Expectations).

We expressly warrant that Spectrum products will be of good quality and workmanship and free from defect for the period set out in the warranty table below from the date of delivery. This warranty shall not apply to defects or damage resulting from misuse, abuse, neglect, improper care, modification or repair not authorized by Spectrum, or any other cause outside the control of Spectrum. Spectrum will, at its sole option, either repair or replace the defective product.

This warranty is exclusive; no other warranty, written or oral, is expressed or implied. This warranty is given by Spectrum to Buyer and to no other person or legal entity. No Spectrum dealer, distributor, agent or employee is authorized to make any modification or addition to this warranty.

NOTWITHSTANDING ANYTHING TO THE CONTRARY, SPECTRUM WILL NOT UNDER ANY CIRCUMSTANCES BE LIABLE FOR INDIRECT OR LIQUIDATED DAMAGES, INCLUDING CONSEQUENTIAL, INCIDENTAL AND SPECIAL DAMAGES. IN NO EVENT SHALL SPECTRUM'S LIABILITY, WHETHER UNDER CONTRACT OR WARRANTY, IN TORT OR OTHERWISE, EXCEED THE PURCHASE PRICE RECEIVED BY SPECTRUM FOR THE PRODUCT AT ISSUE AND "RECALL ACTION" EXPENSES. SPECTRUM SHALL NOT BE SUBJECT TO ANY OTHER OBLIGATIONS OR LIABILITIES, WHETHER ARISING OUT OF BREACH OF CONTRACT, WARRANTY, TORT (INCLUDING NEGLIGENCE AND STRICT LIABILITY) OR OTHER THEORIES OF LAW, WITH RESPECT TO PRODUCTS SOLD OR SERVICES RENDERED BY SPECTRUM, OR ANY UNDERTAKINGS, ACTS OR OMISSIONS RELATING THERETO.

Our Customer Service Department is ready to provide immediate attention to any questions, comments or concerns. They are available to answer your calls Monday through Friday from 7 am to 5 pm CST. In addition your product comments or concerns are welcome via e-mail at: spectrum@spectrumfurniture.com.

Warranty Table

Item	Warranty Period effective 1/1/2015
Adjustable Crank / Electric Desk Legs	• 1 Year
Flat Panel Desk Gas Cylinders	
Chairs <ul style="list-style-type: none"> • Adjustable Height Chair Parts – including frames, gas cylinders, wood and plastic parts, control handles, casters • Adjustable Height Chair Upholstery • In-Stock Upholstery • Graded-In Fabrics and Customer Owned Material 	<ul style="list-style-type: none"> • 7 Years • 2 Years • 2 Years • No Warranty
Height Adjustable Columns and Lifts	• 1 Year
General Use Casters	
Electrical (including timers and LINAK actuators)	• 2 Years
Keyboard / Mouse Trays	• 1 Year
Flat Panel Monitor Arms <ul style="list-style-type: none"> • Flat Panel Monitor Arm – General Parts • Flat Panel Monitor Arm – Gas Cylinders 	<ul style="list-style-type: none"> • 5 Years • 2 Years
Desks and Lecterns <ul style="list-style-type: none"> • Computer Desk Chassis • Cart Chassis • Lectern Chassis 	• 10 Years

