

# Assembly Instructions

## ⚠ Important ⚠

Before you begin, read and comply with all safety and operating instructions, and ensure all parts and correct quantities are included.

Any parts damaged during shipment must be reported within 5 days of receipt. To report information regarding missing parts or damage, to purchase parts or accessories, or if you have any questions, please contact us.

[www.spectrumfurniture.com](http://www.spectrumfurniture.com)  
800-235-1262, 715-723-6750

*Thank you for purchasing Spectrum products!*

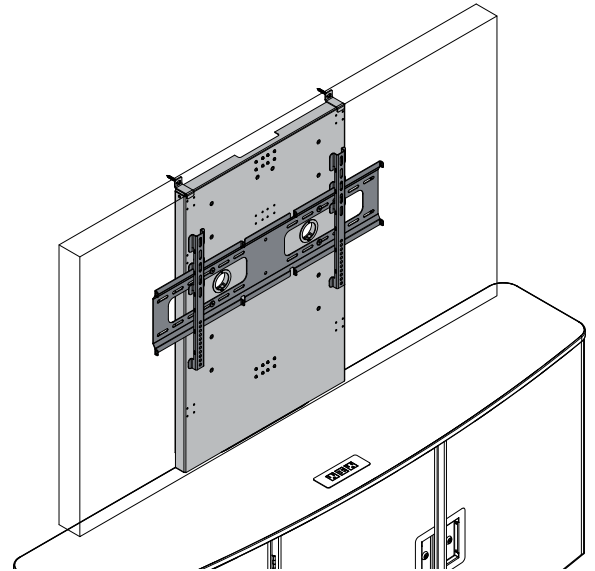

## Display Stand for AV Credenza Slim 55498

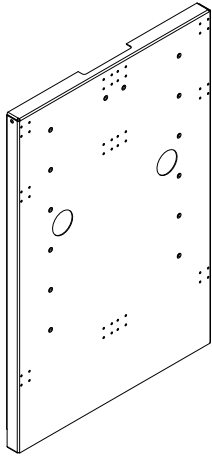

(1) 0145893  
Display Stand

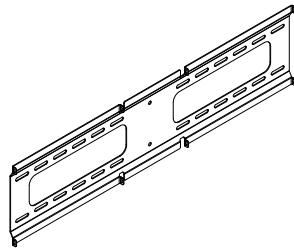

(1) 0119747  
Fixed TV mount

Tools Required



(2) 0146027  
Upright bar



(3) 021587  
8-32 x 1/2" PHMS



(32) 0100167  
8-32 x 1/2" PH thrd cutting screws



(3) 021588  
8-32 Keps nut

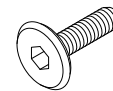

(2) 059534  
1/4-20 x 30mm  
JC bolt

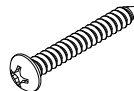

(2) 026436  
#8 x 1-1/4" PHSM  
screw



(4) 052605  
1/4-20 x 15mm  
JC bolts

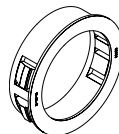

(2) 059984  
2" Grommet

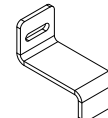

(2) 0148399  
Wall bracket



(2) 0119468  
Recessed bumper  
w/ 1/4" washer

# 1. Install upright bars



1. See **Figure 1.1** if installing onto a 2-Bay credenza, otherwise proceed with step 1.2.
2. Attach the (2) upright bars together with (3) 8-32 x 1/2" PHM screws and (3) 8-32 Keps nuts. **Figure 1.2.**
3. Attach the upright bars to the credenza with 8-32 x 1/2" PH thread-cutting screws.

## 2-Bay Credenzas only:

Note: If installing the stand onto a 2-bay credenza, it will be necessary to remove the (4) screws shown from the credenza frames before installing the upright bars. **Figure 1.1.**

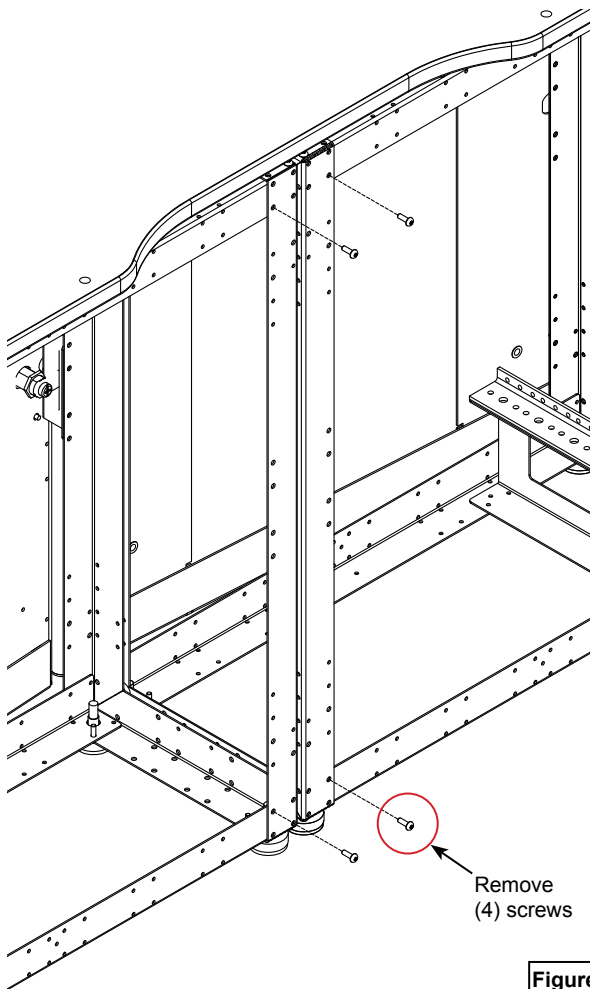

**Figure 1.1**

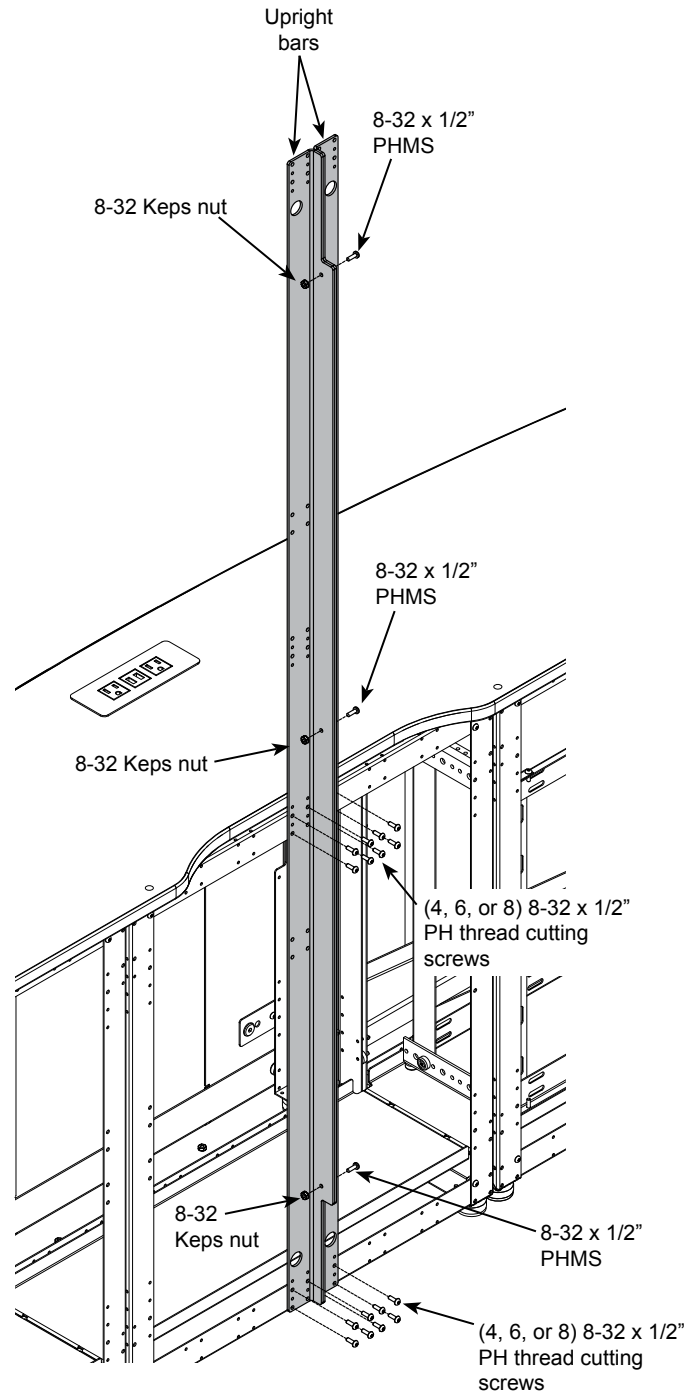

**Figure 1.2**

Note: (4, 6, or 8) 8-32 x 1/2" PHM screws may be used at each upright bar attachment point depending on bay configuration (1, 2, or 3-bay). Be sure a minimum of (4) are used at each location.

## 2. Install bumpers & grommets

1. Install the (2) recessed bumpers into the upper corners of the display stand and tighten securely. **Figure 2.**
2. Install the (2) grommets.

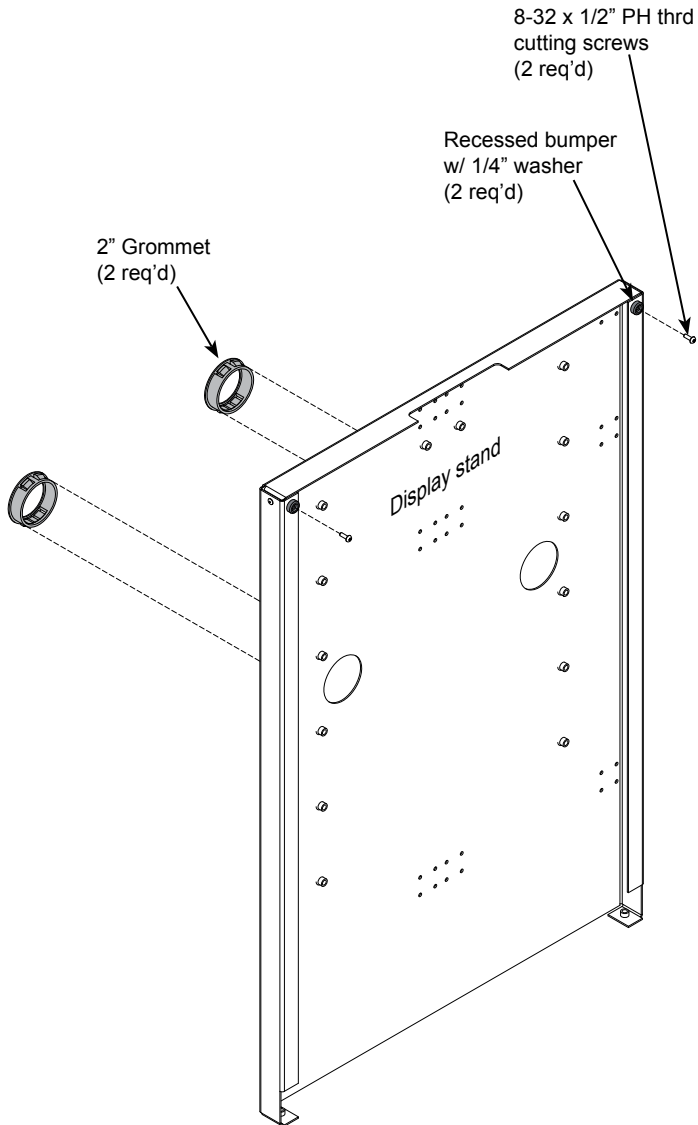

Figure 2

## 3. Install display stand

1. Attach the display stand to the uprights with (16) 8-32 x 1/2" thread-cutting screws. **Figure 3.**
2. Secure the stand to the worksurface with (2) 1/4-20 x 30mm JC bolts.

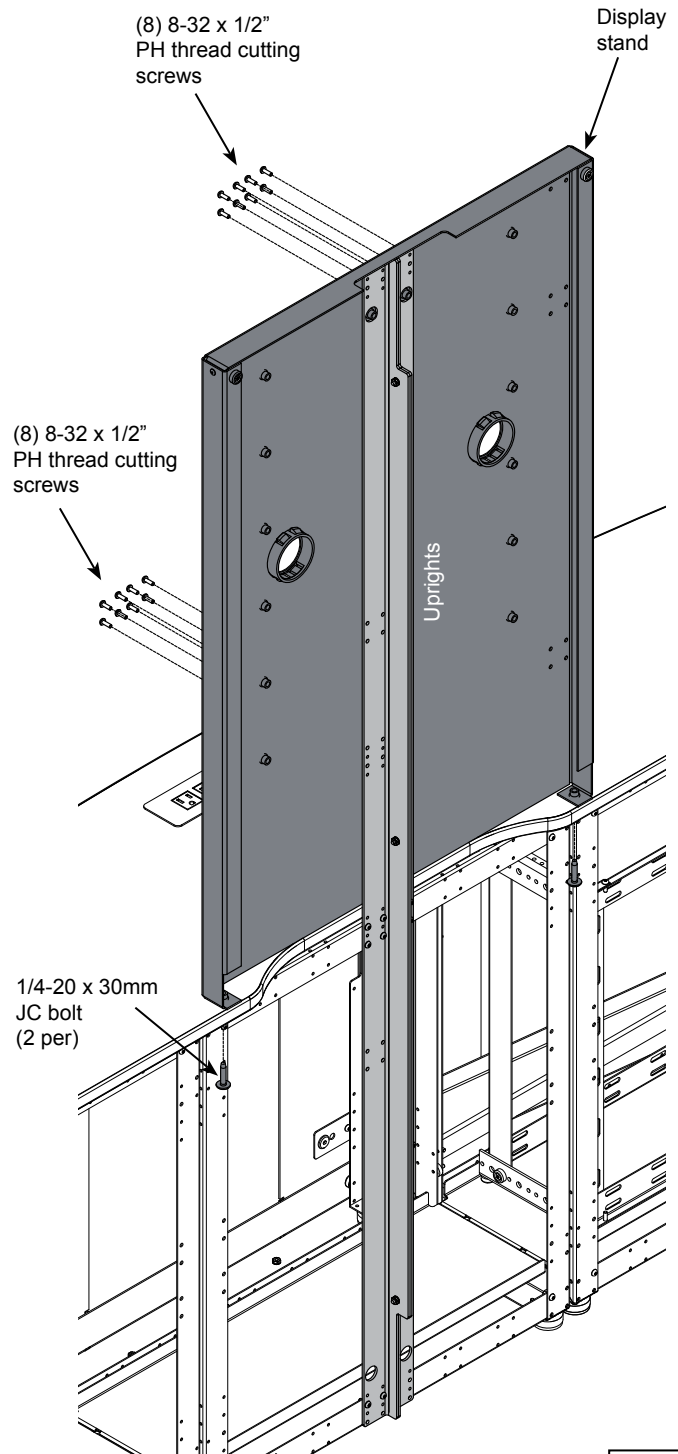

Figure 3

## 4. Install mount & monitor

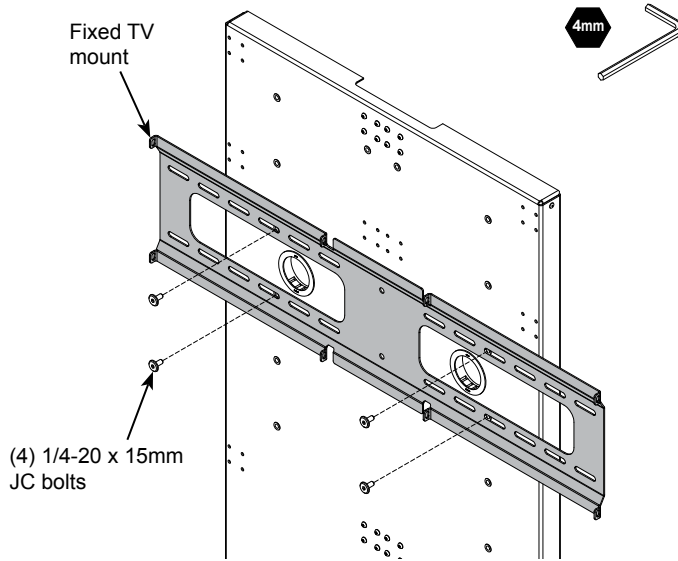

Figure 4



Note: See instructions included with monitor mount for installation and setup.

## 5. Route wires

1. Route monitor wires through the grommets and down into the credenza. **Figure 5.**
2. Secure the stand to the worksurface with (2) 1/4-20 x 30mm JC bolts.

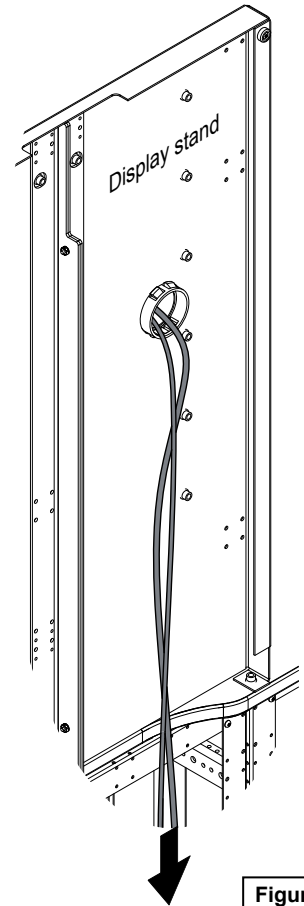

Figure 5

## 6. Install wall brackets

1. Remove the monitor.
2. Locate wall framing (if wall studs) and center the wall brackets on a stud. The bracket can be installed anywhere along the top edge of the display stand. **Figure 6.**
3. Slide the credenza up to the wall so the wall brackets contact the wall. Make sure the credenza is sitting level on the floor. If not sitting level, the glides can be adjusted to level.
4. Using the brackets as a template, drill suitable holes in the wall for the fasteners.
5. Secure each bracket to the wall with (1) wall fastener.



Note: Display stand must be anchored securely to wall studs or a solid wall. (2) #8 x 1-1/4" PHSM screws are provided for wood use.

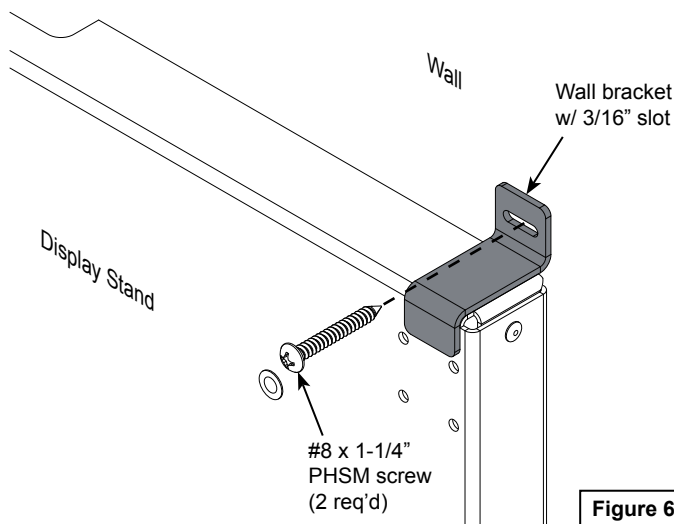
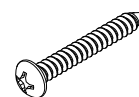

Figure 6

Wall fasteners



(2) 026436  
#8 x 1-1/4" PHSM  
screw