

# Assembly Instructions

## ⚠ Important ⚠

Before you begin, read and comply with all safety and operating instructions, and ensure all parts and correct quantities are included.

Any parts damaged during shipment must be reported within 5 days of receipt. To report information regarding missing parts or damage, to purchase parts or accessories, or if you have any questions, please contact us.

[www.spectrumfurniture.com](http://www.spectrumfurniture.com)  
800-235-1262, 715-723-6750

*Thank you for purchasing Spectrum products!*

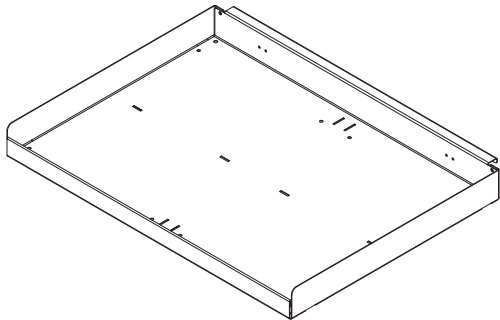
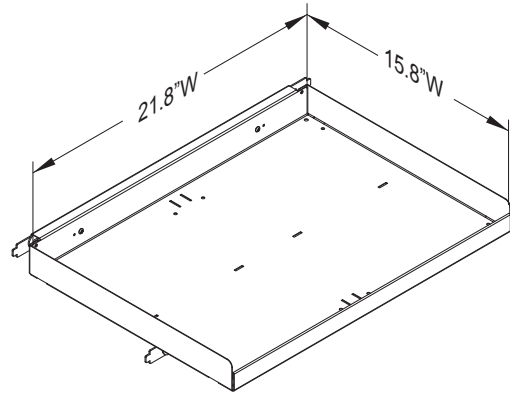

(1) 0147901  
Tray

## Accessory Shelf 55515

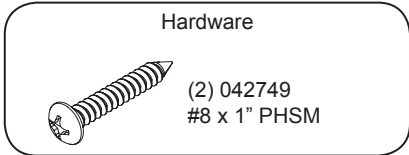

(4) 056284  
8-32 Wing nut

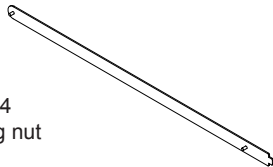

(2) 0142528  
Bar support  
(with threaded  
weld studs)

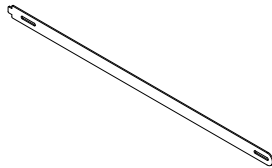

(2) 0145039  
Bar support B-side  
(with slots)

## 1 Assemble bar supports

1. The bars should be assembled with the tabs facing away from each other as shown in **Figure 1**.
2. Loosen the (2) wingnuts slightly.
3. Repeat for the 2nd set of bars.

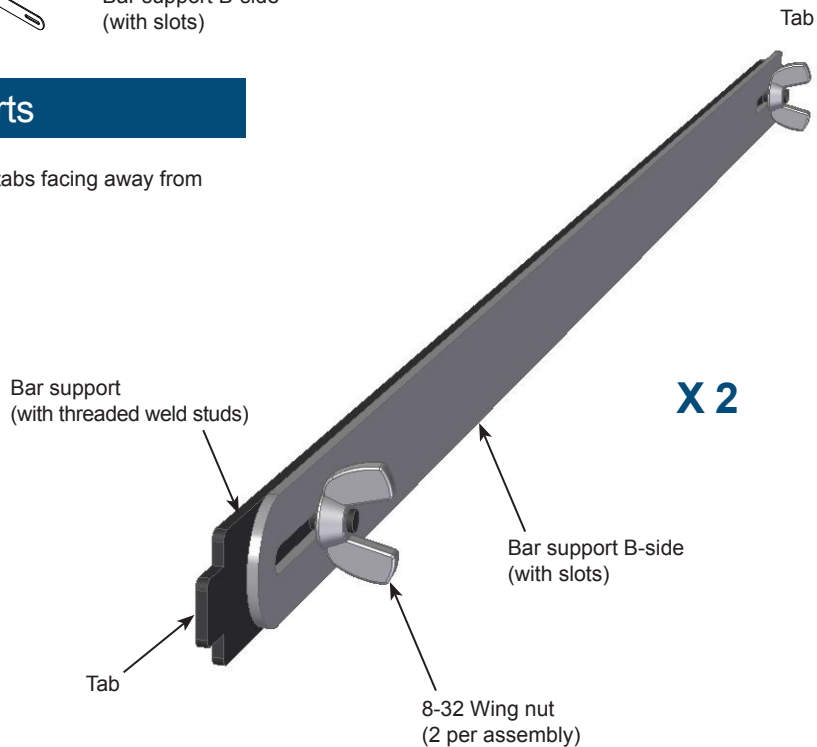

**Figure 1**

## 2 Install bars into cart

1. Determine the approximate location (height) you would like the shelf to be mounted. The rear bar is (1) slot higher than the front.
2. Insert one tab into a slot in the left slotted upright. **Figure 2.**
3. Insert the opposite tab into the corresponding right slotted upright and fully extend the bar assembly into place.
4. Lock the extended position of the bars by securely tightening the (2) wingnuts. Be sure both wingnuts are tight.
5. Repeat for the 2nd set of bars.

Note: When determining the location of the shelf, be sure it will clear any obstructions that may be inside the cabinet and enough clearance (height) is provided for all devices.

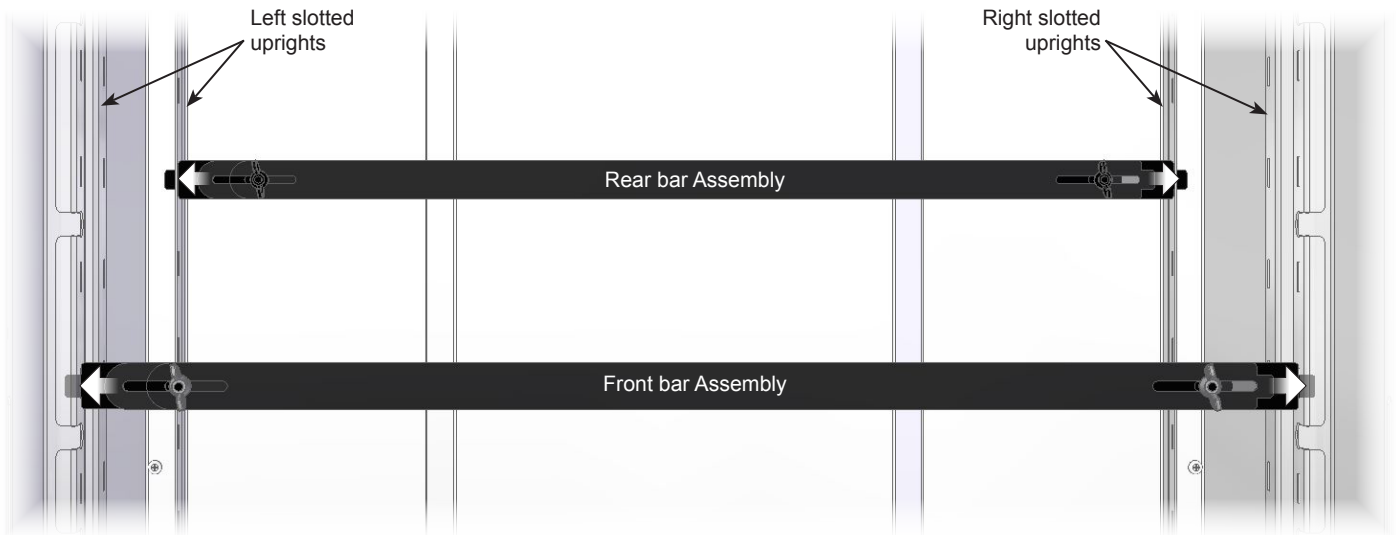

Figure 2

## 3 Install accessory shelf onto bars

1. Carefully set the empty accessory shelf onto both sets of bars. Be sure the rear channel "hooks" the rear set of bars fully. **Figure 3.1.**
2. Install (2) #8 x 1" PHSM screws into the back of the module-this will prevent removal. **Figure 3.2.**

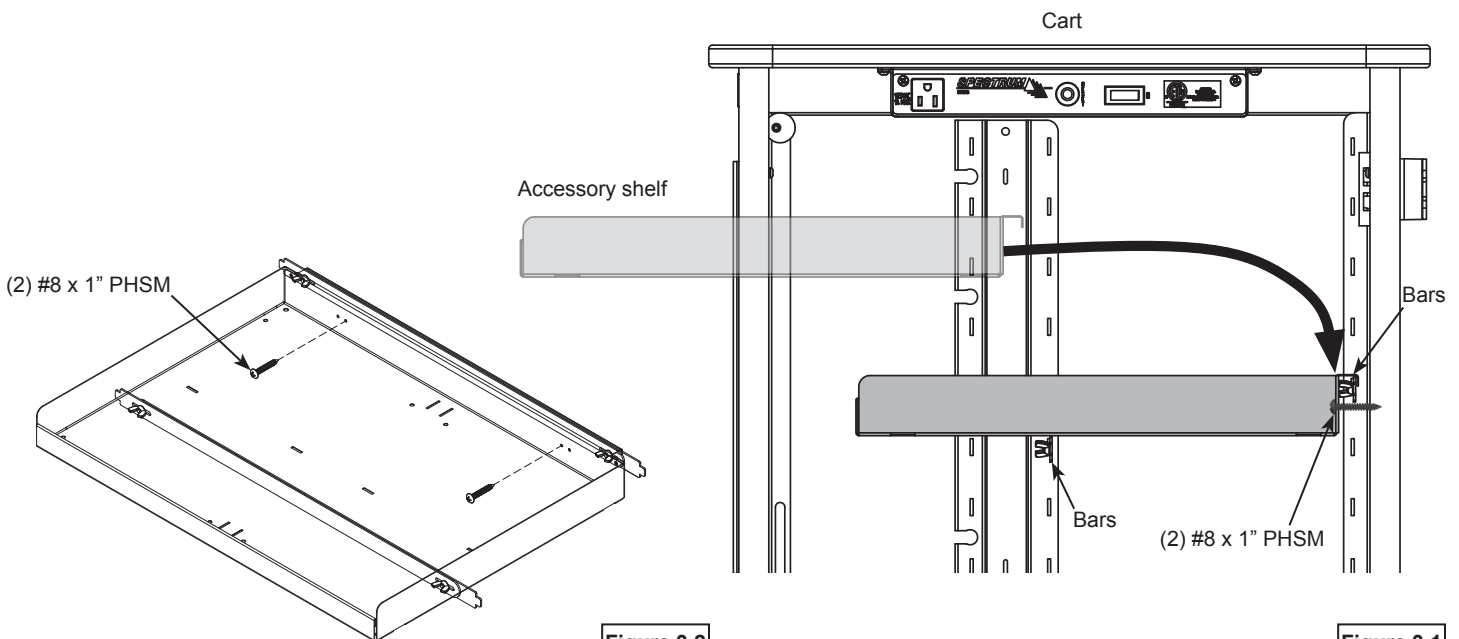
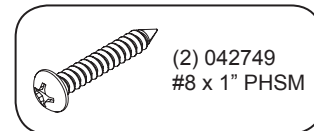

Figure 3.2

Figure 3.1