

## Technical Specifications

55497

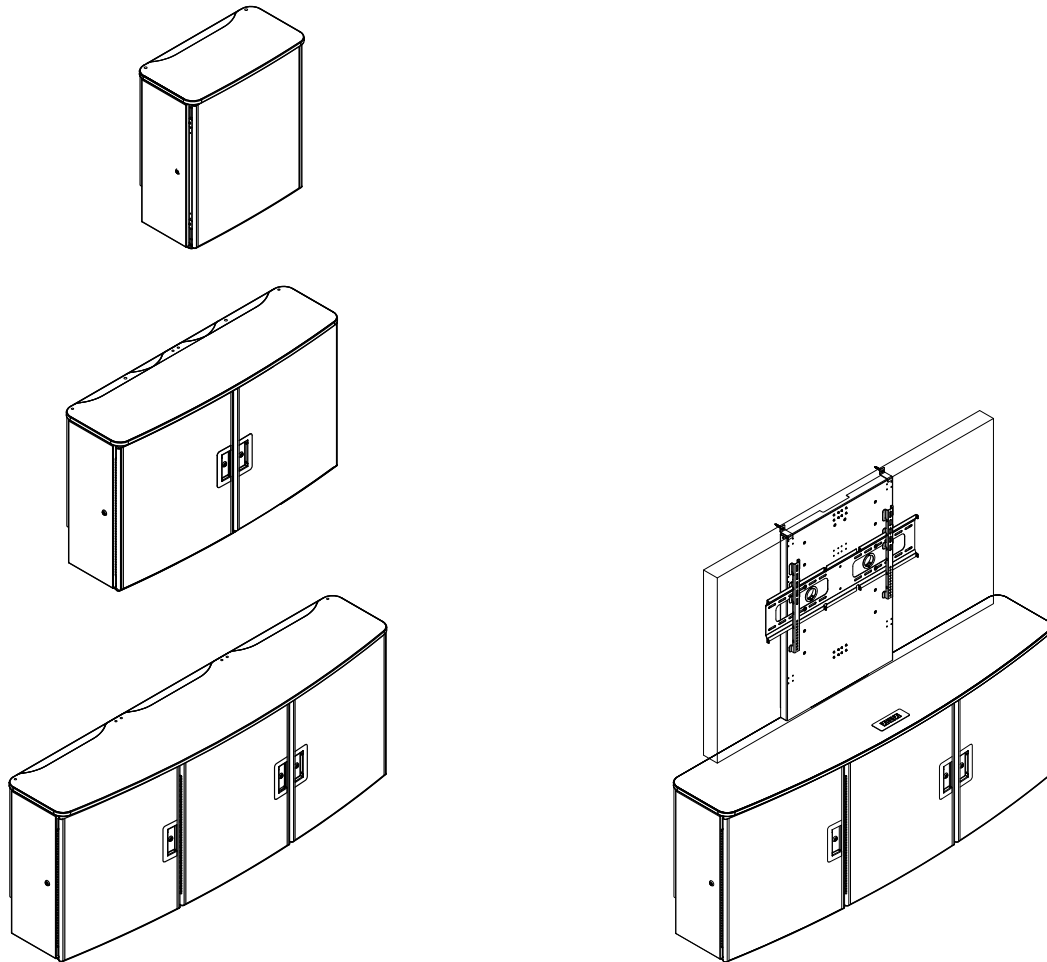

*The AV Credenza Slim is a fully customizable credenza that can accommodate AV equipment using a removable rack cube, or fixed rack rail in a sleek modern finish. Available in 1, 2, or 3 bay models, the credenza can be used in conference rooms, training or classrooms. Spectrum's technology enhanced credenza is available with display stands to incorporate TV monitors, eliminating wall mounted displays.*

## Features and Benefits

- Available in 1-bay (25.5"W), 2-bay (50.5"), or 3-bay (73.5") versions
- Slim depth (13.6"D) saves valuable space
- Available with 3RU fixed or 3RU removable rack cube
- Locking side panels simplify accessibility and component installation
- Optional cam lock hasp doors available on double or triple bay units provide superior protection and security
- Ventilated door and side panels keep components cool, preventing overheating, and extending device life
- Optional 3RU rack cube(s) provide removable rack capability
- Optional 3RU fixed rack provides stationary rack capability
- Optional display stand provides monitor mounting
- Optional dual display mount provides dual monitor mounting
- Optional Camera mount provides mounting location for a video teleconferencing camera
- Optional power module provides worksurface power
- Ships fully-assembled for quick, simple integration and deployment
- Durable powder coated steel chassis provides a long-lasting finish
- Warranted to be free of all defects in materials and workmanship for 10 years
- Designed and assembled in Chippewa Falls, WI, USA

### Color Options

Available in Spectrum Expressions colors.  
See [spectrumfurniture.com](http://spectrumfurniture.com) for complete color information.

### Ordering Instructions

Spectrum has designed this product to receive the useful options shown here.  
To ensure your options are ordered correctly please call 1-800-235-1262.

# Construction

- 14-gauge doors, 16-gauge chassis
- All metal components are finished with a scratch-resistant powder coat epoxy
- Top panel is constructed from 3/4" NAF (No Added Formaldehyde) composite board
- Top panel edges are covered with 3mm vinyl edgeband
- Factory-assembled, packaged, and shipped on its own skid. Display stand requires customer assembly.

# Specifications

Bay capacity (nominal)	23.63"W [60 cm] x 9.89"D [25.1 cm] x 28.1"H [71.4 cm]	
	<i>Note: Fasteners and glide depth will influence overall effective bay capacity</i>	
Certifications / Compliance	<ul style="list-style-type: none"> <li>• ETL recognized</li> <li>• SCS Indoor Advantage Certified</li> </ul>	<ul style="list-style-type: none"> <li>• Meets or exceeds applicable ANSI-BIFMA test standards</li> </ul>
Unit weight (nominal)	50 lb [22.7 kg] - 1-Bay w/ panel 100 lb [45.4 kg] - 2-Bay w/ panels 150 lb [38.6 kg] - 3-Bay w/ panels	105 lb [47.7 kg] - 2-Bay w/ doors 155 lb [70.4 kg] - 3-Bay w/ doors
Shipping weight (nominal)	75 lb [34 kg] - 1-Bay w/ panel 125 lb [56.75 kg] - 2-Bay w/ panels 180 lb [81.72 kg] - 3-Bay w/ panels	130 lb [59 kg] - 2-Bay w/ doors 185 lb [84 kg] - 3-Bay w/ doors

*Specifications subject to change without notice*

Bays

ORDER CODE 1 = 1-Bay

ORDER CODE 2 = 2-Bay

ORDER CODE 3 = 3-Bay

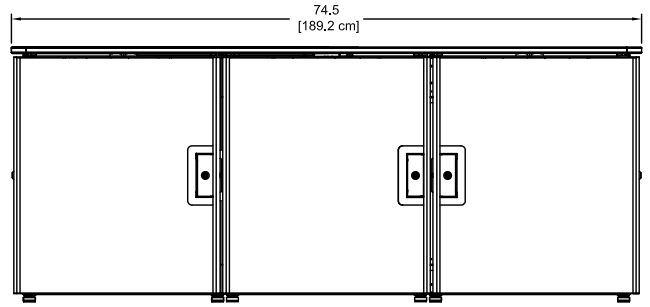
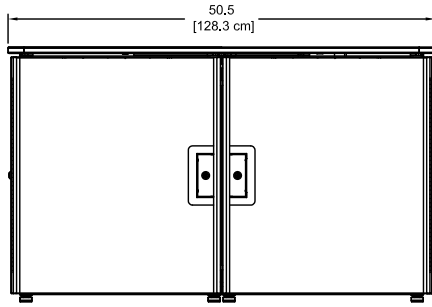
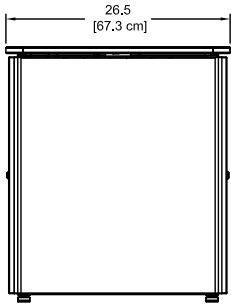

Door Options

ORDER CODE 2 = Solid panel

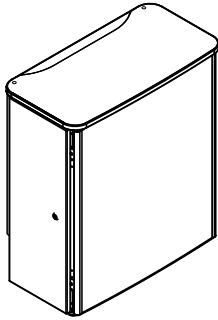

1-Bay

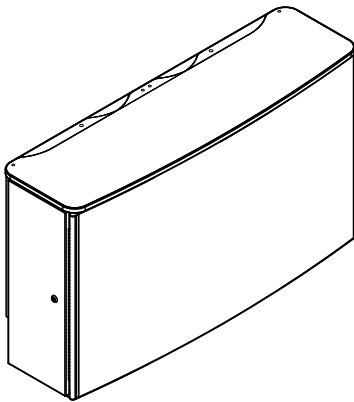

2-Bay

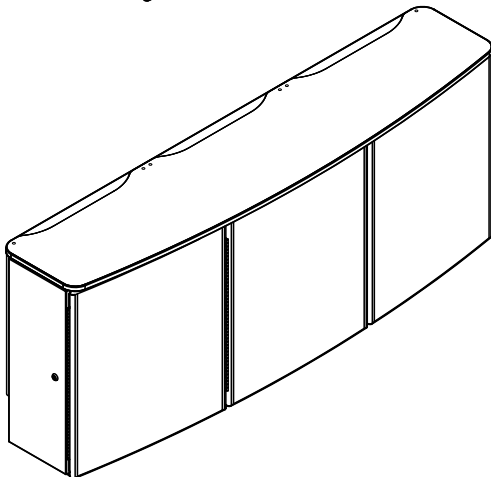

3-Bay

ORDER CODE 3 = Cam lock hasp

Note: Cam lock hasp not available on 1-bay units.

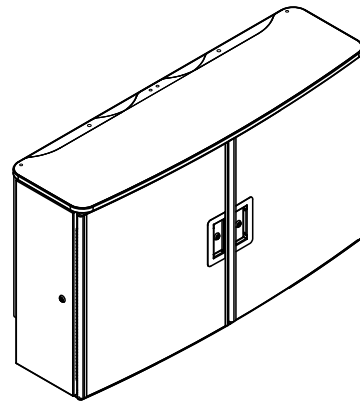

2-Bay

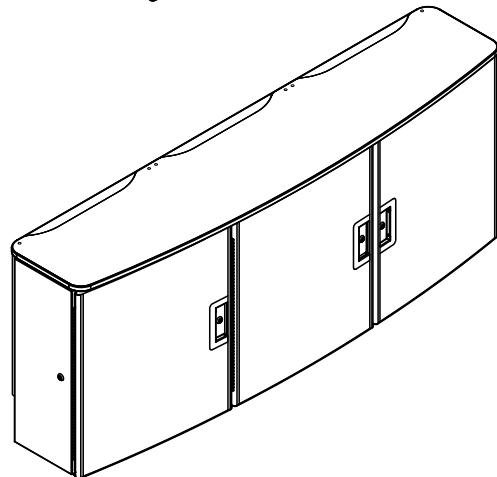

3-Bay

**ORDER CODE 0 = None**

*Rack options dependent on bays ordered. Request a quote online for details.*

- ORDER CODE A = Fixed 3RU left**
- ORDER CODE B = Fixed 3RU right**
- ORDER CODE C = Fixed 3RU center**
- ORDER CODE D = Fixed 3RU left, right**
- ORDER CODE E = Fixed 3RU left, center, right**

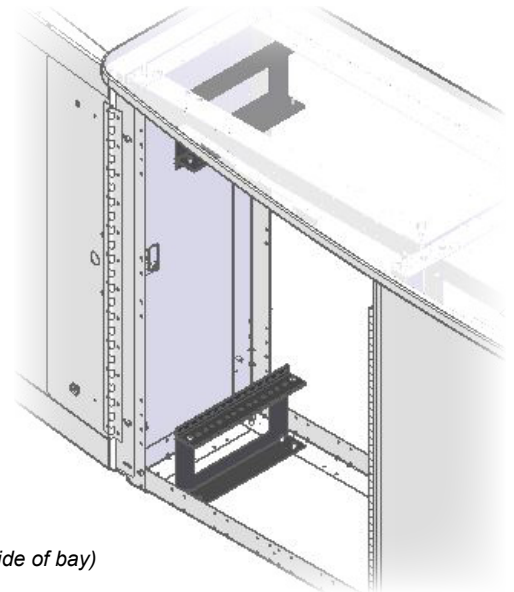

**ORDER CODE F = 1 removable 3RU Rack cube**

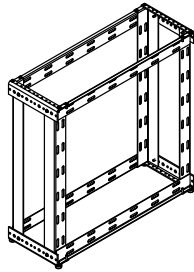

**ORDER CODE G = 2 removable 3RU Rack cubes**

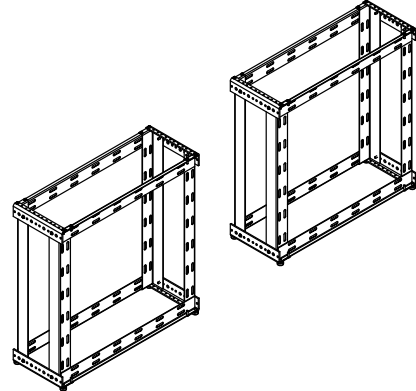

**ORDER CODE H = 3 removable 3RU Rack cubes**

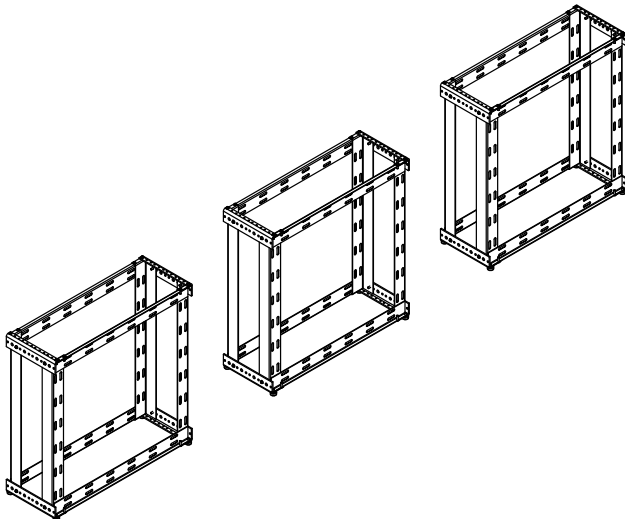

ORDER CODE 0 = None

ORDER CODE A = Power Module - Black

ORDER CODE B = Power Module - Silver

ORDER CODE C = Power Module - White

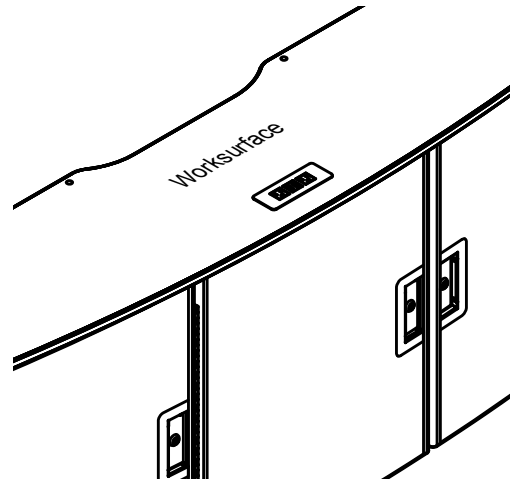
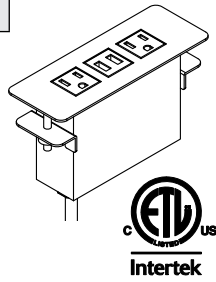

ORDER CODE D = Power Module - Black & EM Wireless Charging Pad

ORDER CODE E = Power Module - Silver & EM Wireless Charging Pad

ORDER CODE F = Power Module - White & EM Wireless Charging Pad

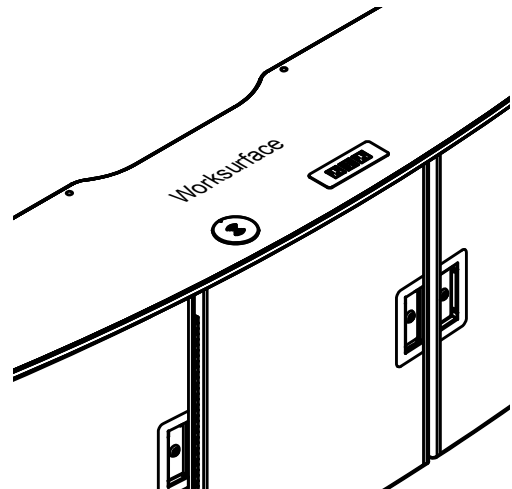
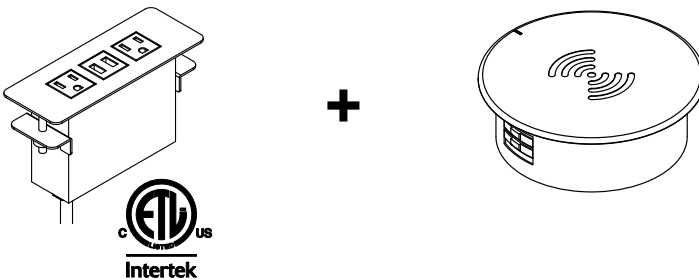

ORDER CODE G = Wireless Charging Pad

ORDER CODE H = Custom

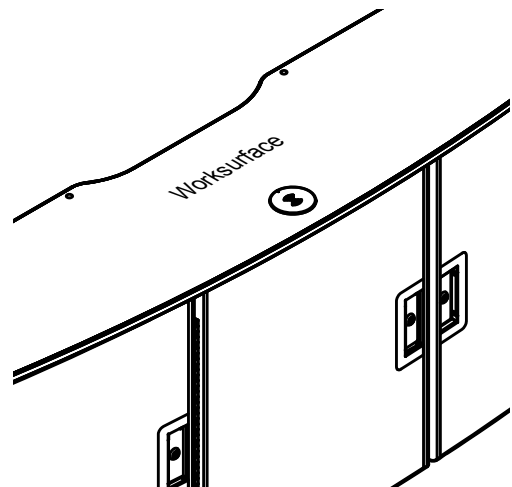
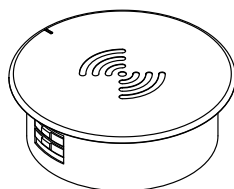

## Display Options

*Display options dependent on bays ordered. Request a quote online for details.*

Note: Display stand requires anchoring to wall-hardware included.

Note: If a display stand is specified, a clearance cutout (or cutouts) will be designed into the rear workspace edge to accommodate.

**ORDER CODE 0 = None**

**ORDER CODE A = (1) Single display**

*\*Most common display option*

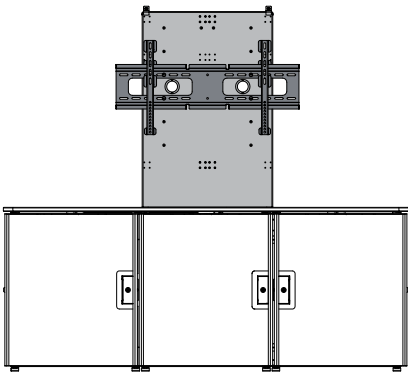

**ORDER CODE B = (2) Single displays**

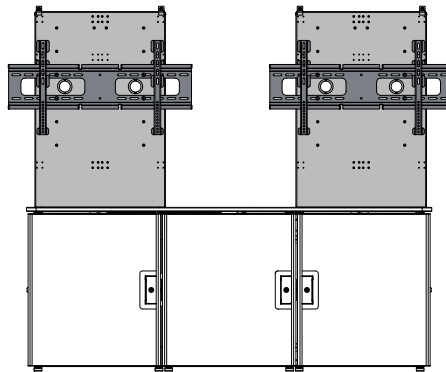

**ORDER CODE C = (3) Single displays**

*Note: 3 single monitor display stands will only fit up to 2 monitors horizontally*

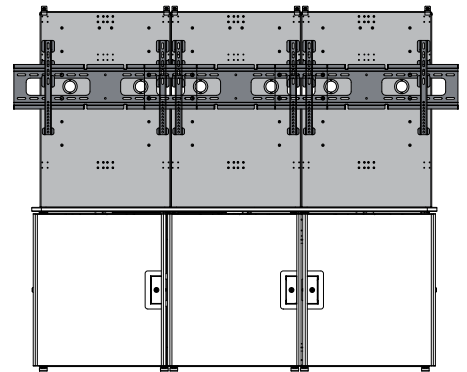

**ORDER CODE D = (1) Dual display**

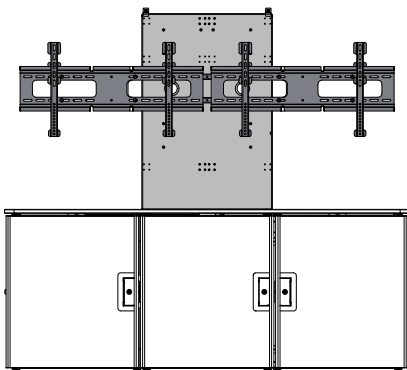

**ORDER CODE E = (2) Dual displays**

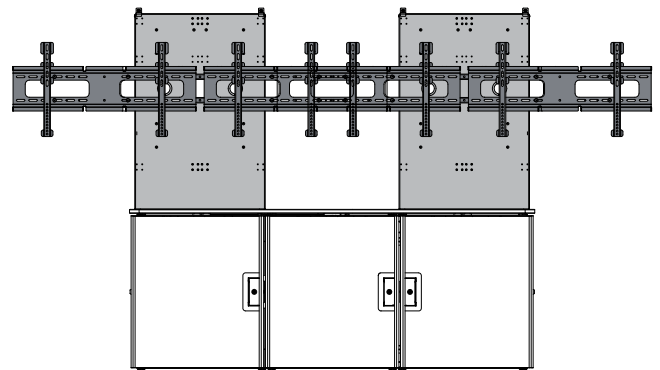

## Camera Mount

**ORDER CODE 0 = None**

**ORDER CODE 1 = Camera Mount**

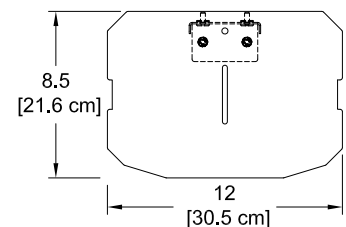
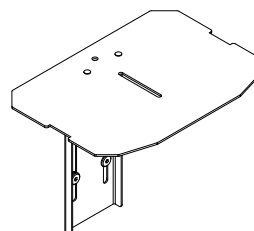

1-Bay  
(available with solid panel only)

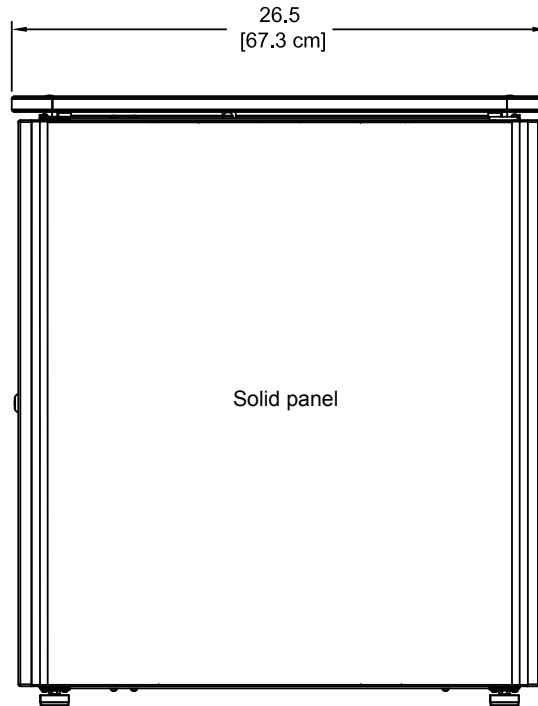
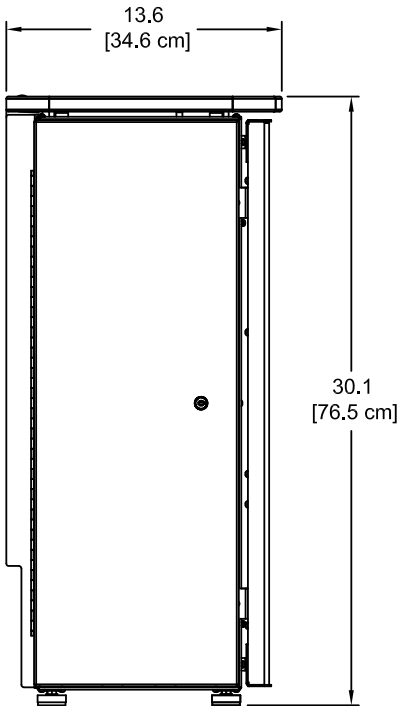
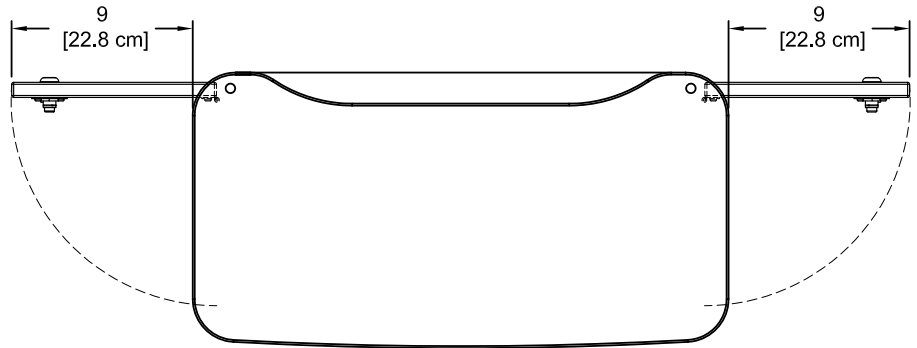
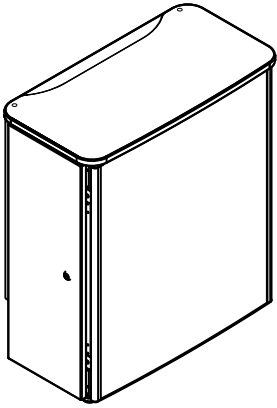

2-Bay  
(shown with doors)

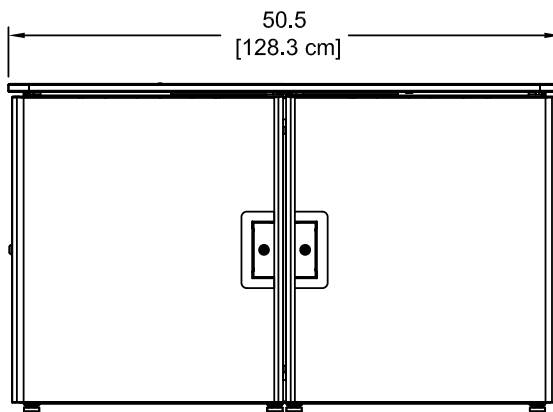
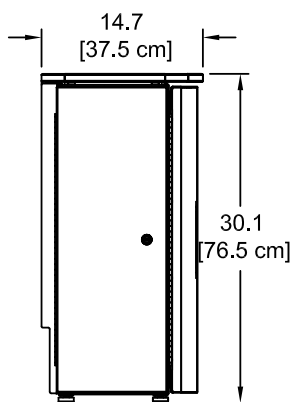
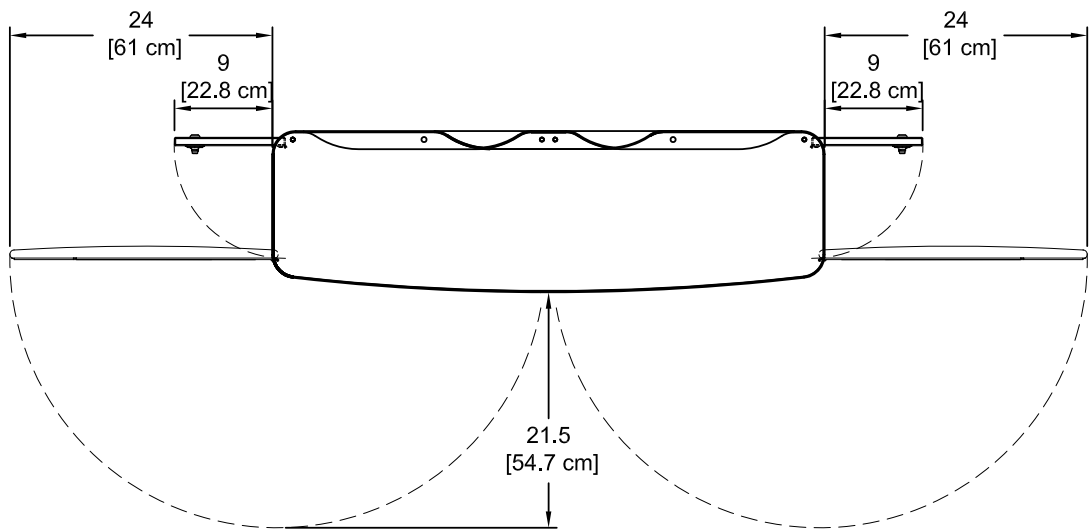
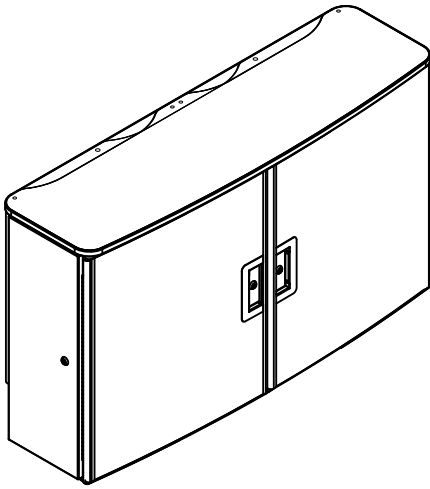



3-Bay  
(shown with doors)

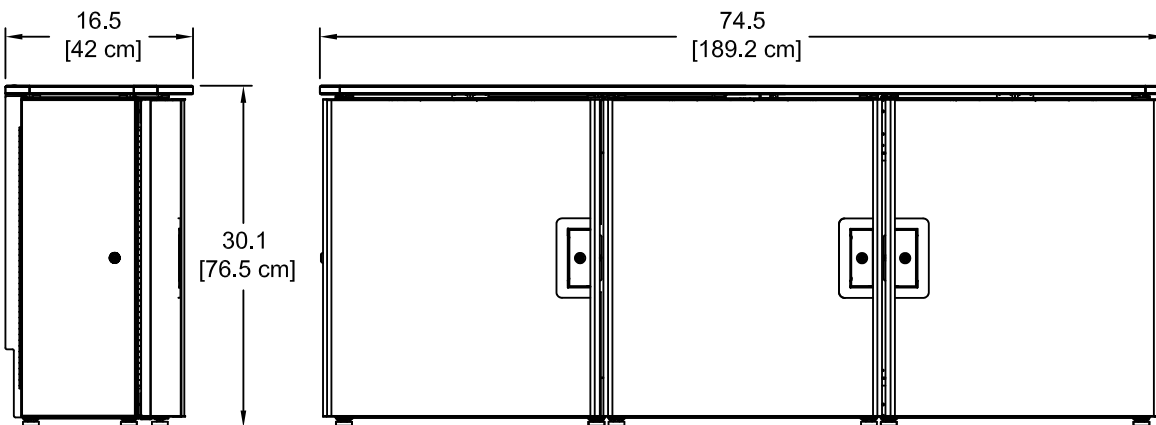
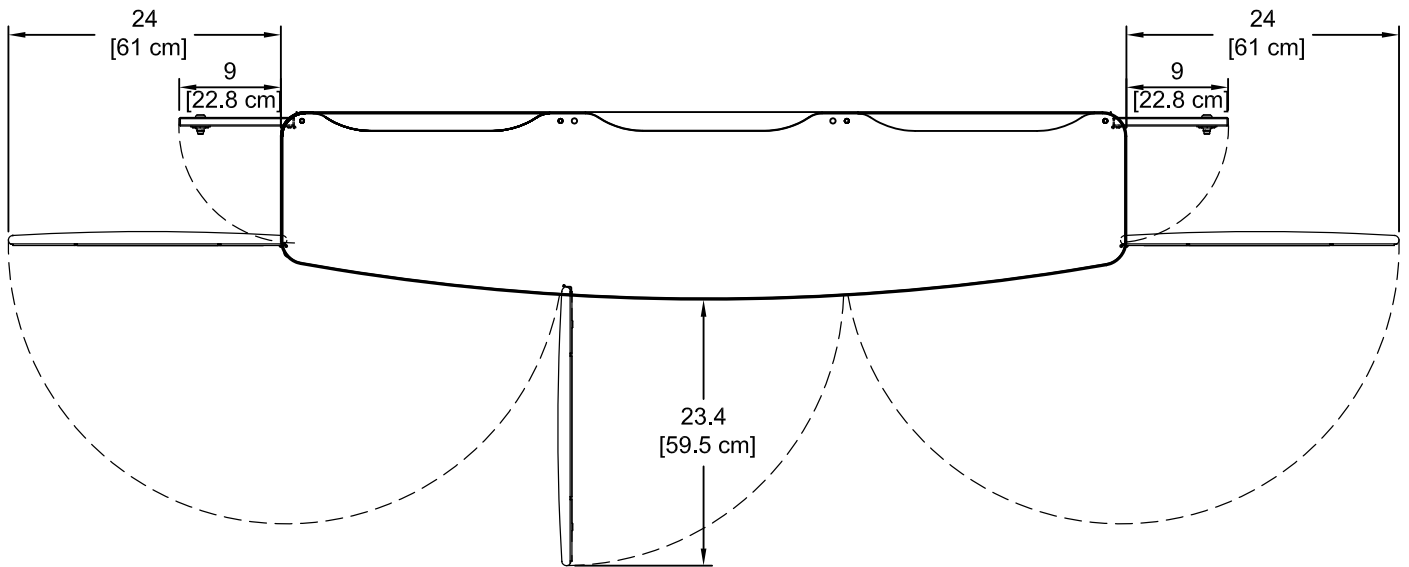
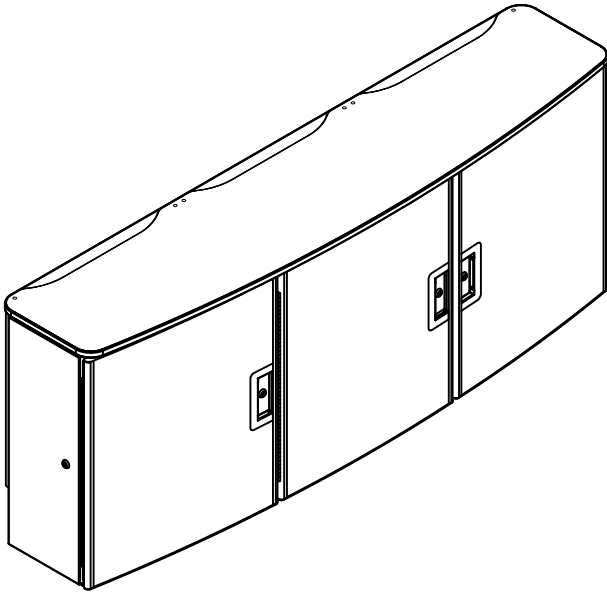

# Accessories

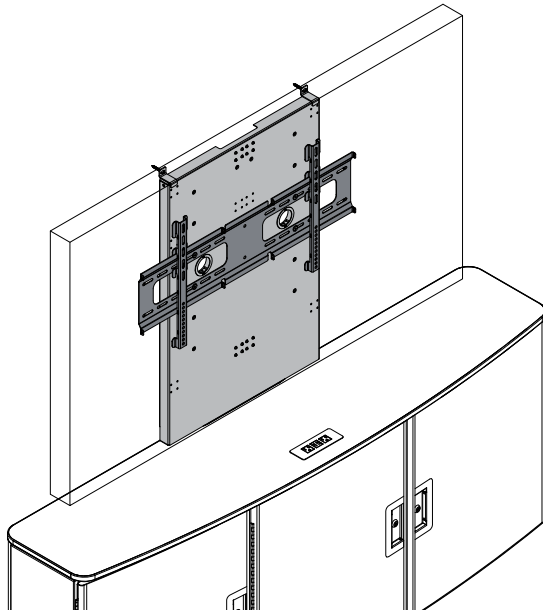

## Display Stand - 55498

- Secured to worksurface and wall
- Cord grommets in wall panel route and hide wires
- Slim adjustable VESA mount (non-tilting)

Monitor size range: 37"-70" [94-177.8 cm] diagonal

VESA compatibility:	200 x 200	600 x 400
	400 x 200	400 x 400
	300 x 300	800 x 400

Max monitor weight capacity: 125 lb [75 kg]

Unit weight: 22.5 lb [10.2 kg]

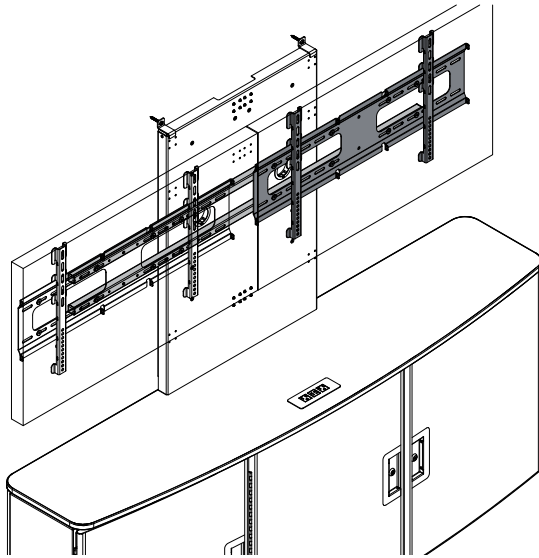

## Dual Display Mount - 55499

- Accommodates two monitors up to 42" [106.7 cm]
- Includes (1) VESA display mount
- Includes (2) support tubes
- Adjustable left-to-right
- Requires Display Stand 55498

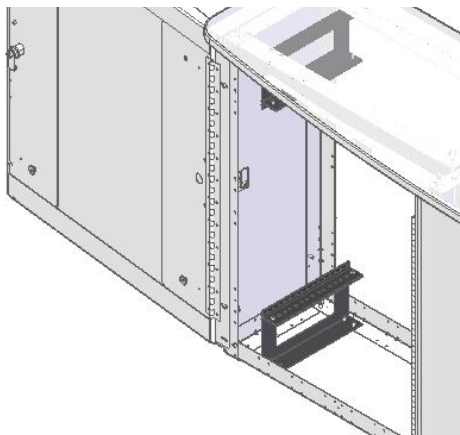

## 3RU Fixed Rack - 55516

- Includes (2) 3RU rack rails
- Includes (2) mounting brackets
- Black powdercoat
- Shipping weight: 5 lb [2.3 kg]

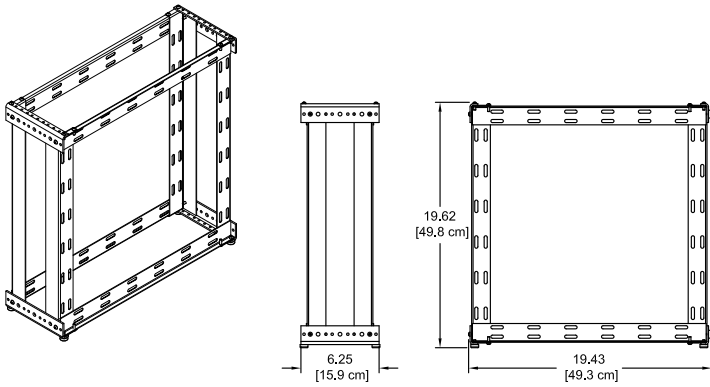

### 3RU Rack Cube - 55517

- Provides ability to integrate equipment remotely before installation into the unit
- (1) rack cube can be installed per bay
- Bumpers on two sides
- Cube can be oriented with equipment horizontal or vertical
- Can be secured to base panel
- Black powdercoat
- Customer-installed

Rack rail:	3RU front and rear
Dimensions:	19.43"W [49.3 cm] x 6.25"D [15.9 cm] x 19.62"H [49.8 cm]
Equipment depth	up to 19"
Steel	16ga
Unit weight:	10.5 lb [4.8kg]
Shipping weight:	11.5 lb [5.2 kg]

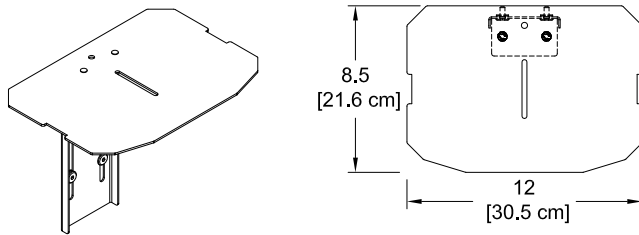

### Camera Mount - 55518

- Provides ability to mount camera for video teleconferencing
- Requires optional Display Stand 55498, or 55499
- Mounts above monitor(s) for group teleconferencing
- Adjustable height shelf bracket provides ideal height
- Shipping weight: 5 lb [2.3kg]

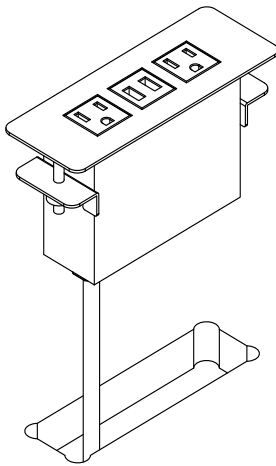

### Power Module - 99058

- (2) AC power receptacles
- (2) USB charge ports
- Aluminum housing and flange
- Thumbscrew clamps
- Requires worksurface cutout
- ETL-certified
- Available in black, silver, or white
- Customer-installed

Cutout required:	5.65"W [14.35 cm] x 1.65"D [4.19 cm]
Power cord:	9' [274 cm] 14AWG *3C power cord
Power receptacles:	125V, 60hz, 15A tamper-resistant
USB charging ports:	2.1A (10.5W) (not data-compatible)
Dimensions:	6.38"W [16.2 cm] x 2.36"D [6 cm] x 3.54"H [9 cm]
Unit weight:	2 lb [.9 kg]
Shipping weight:	2.35 lb [1 kg]

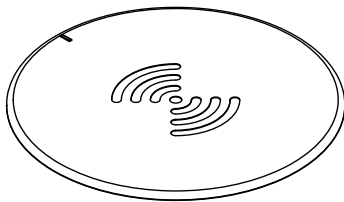

### EM Wireless Charging Pad - 99057

- Uses electromagnetic technology to charge Qi V1.2 compliant IC devices ("Qi" enabled)
- LED to confirm pairing / charging
- Security tab prevents theft
- Requires 3" round cutout to be made by customer
- UL-certified

Cutout required:	3" dia (by customer)
Input:	DC 5V (with included DC5V.2A power adapter)
Output:	5W max (with included DC5V.2A power adapter)
Power cord:	8' [244 cm] with DC jack
Dimensions:	3.5" dia [8.9 cm] x 1.125"H [2.9 cm]
Shipping weight:	1 lb [.45 kg]

Note: The unit requires a 7" diameter of clearance to work with Qi-enabled phones placed in any orientation. The 3" dia cutout should be located on the worksurface at least 3.5" from any edge.

See [spectrumfurniture.com](http://spectrumfurniture.com) for the latest accessories and detailed warranty information.

# Warranty

## We will make it right for you!

Spectrum is committed to provide complete customer satisfaction. Each of our products is manufactured from the best materials available and each product is stringently monitored throughout the production process through our Quality Management System.

We expressly warrant that Spectrum products will be of good quality and workmanship and free from defect for the period set out in the warranty table below from the date of delivery. This warranty shall not apply to defects or damage resulting from normal wear and tear, misuse, or unintended use, failure to follow instructions related to the product's installation or intended use, abuse, neglect, improper care, modification or repair not authorized by Spectrum, or any other cause outside the control of Spectrum. Spectrum will, at its sole option, either repair or replace the defective product.

This warranty is exclusive; no other warranty, written or oral, is expressed or implied. This warranty is given by Spectrum to Buyer or Buyer third party end user and to no other person or legal entity. No Spectrum dealer, distributor, partner, reseller, agent or employee is authorized to make any modification or addition to this warranty.

**NOTWITHSTANDING ANYTHING TO THE CONTRARY, SPECTRUM WILL NOT UNDER ANY CIRCUMSTANCES BE LIABLE FOR INDIRECT OR LIQUIDATED DAMAGES, INCLUDING CONSEQUENTIAL, INCIDENTAL AND SPECIAL DAMAGES. IN NO EVENT SHALL SPECTRUM'S LIABILITY, WHETHER UNDER CONTRACT OR WARRANTY, IN TORT OR OTHERWISE, EXCEED THE PURCHASE PRICE RECEIVED BY SPECTRUM FOR THE PRODUCT AT ISSUE AND "RECALL ACTION" EXPENSES. SPECTRUM SHALL NOT BE SUBJECT TO ANY OTHER OBLIGATIONS OR LIABILITIES, WHETHER ARISING OUT OF BREACH OF CONTRACT, WARRANTY, TORT (INCLUDING NEGLIGENCE AND STRICT LIABILITY) OR OTHER THEORIES OF LAW, WITH RESPECT TO PRODUCTS SOLD OR SERVICES RENDERED BY SPECTRUM, OR ANY UNDERTAKINGS, ACTS OR OMISSIONS RELATING THERETO.**

Our Customer Service Department is ready to provide immediate attention to any questions, comments or concerns. They are available to answer your calls Monday through Friday from 7 am to 5 pm CST. In addition your product comments or concerns are welcome via e-mail at: [spectrum@spectrumfurniture.com](mailto:spectrum@spectrumfurniture.com).

Warranty Table

Item	Warranty Period
Desk, table, cart and lectern chassis	10 Years
Electrical	2 Years
Flat panel monitor arms / gas spring / general parts	2 Years
Adjustable crank / electric legs and accessories	2 Years
Flat panel desk gas spring cylinders	2 Years
Height adjustable columns, lifts & accessories	2 Years
Casters & wheels	2 Years
Keyboard, mouse, trays	2 Years
Locks & keys	2 Years
Tubs, totes and other accessories	1 Year
Chairs Structural components, including gas cylinders, wood, metal and plastic parts (i.e., chair frames, bases and control handles)	7 Years
Consumable items (i.e., casters, glides, etc.)	5 Years
In-stock upholstery	5 Years
Customer supplied material	No Warranty



Spectrum Industries Inc.  
is Certified ISO 9001:2015