

Assembly Instructions

⚠ Important ⚠

Before you begin, read and comply with all safety and operating instructions, and ensure all parts and correct quantities are included.

Any parts damaged during shipment must be reported within 5 days of receipt. To report information regarding missing parts or damage, to purchase parts or accessories, or if you have any questions, please contact us.

www.spectrumfurniture.com
800-235-1262, 715-723-6750

Thank you for purchasing Spectrum products!

Assembly Tips:

- Assemble the console in its final location.
- To facilitate assembly, keep the fasteners finger-tight until the console is completely together. Then tighten securely.

Note: The items below represent all the structural components available for the Instructor Media Console. Due to the various console configurations and order combinations available, some of the items shown here may not be included with your particular unit, and some assembly steps may not apply. Before beginning assembly, please review these instructions.

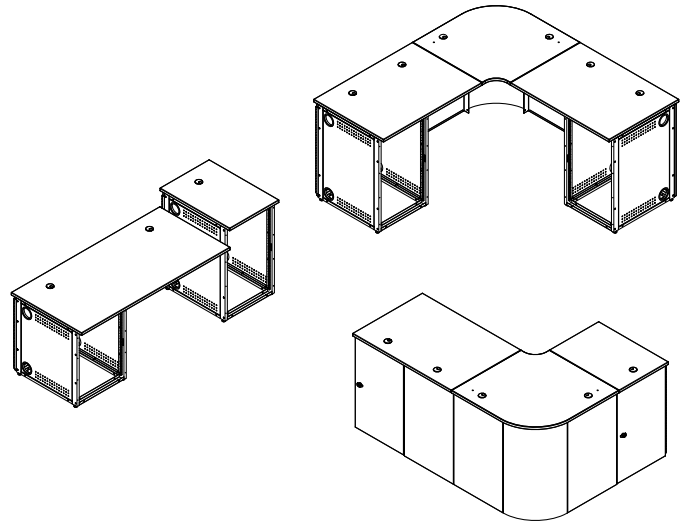

Instructor Media Console 68XXX series

Touchboards

205 Westwood Ave, Long Branch, NJ 07740
Phone: 866-94 BOARDS (26273) / (732)-222-1511
Fax: (732)-222-7088 | E-mail: sales@touchboards.com

Tools Required



Drill with
Phillips driver
(best)



Phillips
screwdriver





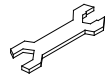





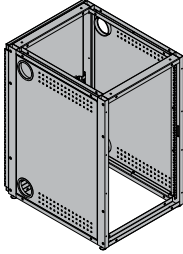







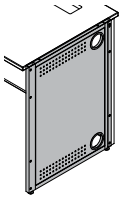



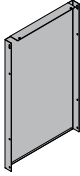

4mm Hex
Wrench
(included)

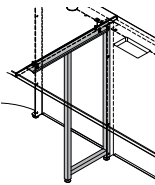

Glide Wrench
(included when
applicable)

	Product #	Description	Hardware
	68156	36" Radius Corner	(26) 1/4-20 x 15mm JC bolt - 052605 (6) 1/4-20 Flanged locknut - 0108896 (2) 1/4-20 x 50mm JC bolt - 038047 (2) 5/16-18 x 1" Glide - 037779 (2) Unit-to-unit bracket - 037749
	68106	29" Radius Corner	(2) Worksurface bracket - 044069 (3) Cord clip - 044207 (1) 4mm Hex wrench - 025039 (1) Glide wrench - 025069
	68202	Triple Worksurface	(4) 1/4-20 x 15mm JC bolt - 052605 (2) Unit-to-unit bracket - 037749
	68201	Double Worksurface	(1) 4mm Hex wrench - 025039 (6) #6 x 5/8" PHSM screws - 025044
	68200	Single Worksurface	

	Product #	Description	Hardware
	68157	36" Equipment Rack	 (4) 1/4-20 x 15mm JC bolt - 052605  (2) Adhesive bumper - 044573  (4) 5/16-18 x 1" Glide - 037779
	68107	29" Equipment Rack	 (1) 1/4-20 x 90mm JC bolt - 039065  (1) 1/4-20 Flanged locknut - 0108896  (1) 4mm Hex wrench - 025039  (1) Glide wrench - 025069
	68155	36" End Support Leg	 (2) 5/16-18 x 1" Glide - 037779  (2) 1/4-20 x 40mm JC bolt - 021581  (6) 8-32 x 1/2" PH thread-cutting - 0100167
	68105	29" End Support Leg	 (2) 4" Snap-in grommet - 0104836  (1) 4mm Hex wrench - 025039  (1) Glide wrench - 025069
	68151	36" Wall Filler Panel	 (10) 1/4-20 x 15mm JC bolt - 052605  (4) 1/4-20 Flanged locknut - 0108896
	68101	29" Wall Filler Panel	 (1) 4mm Hex wrench - 025039  (2) Cord clip - 044207
	68154	36" Mid-Support Leg	 (4) 1/4-20 x 15mm JC bolt - 052605  (2) 5/16-18 x 1" Glide - 037779
	68104	29" Mid-Support Leg	 (1) 4mm Hex wrench - 025039  (1) Glide wrench - 025069

Worksurface Support Guidelines

For adequate support, areas under worksurfaces generally should not exceed a span of more than 2 open spaces (or wall filler panels) wide.

- When a radius corner is used with two double worksurfaces that have equipment rack support, a mid-support leg usually is not necessary
- When a radius corner is next to a double worksurface, an equipment rack or mid-support leg should be used to support the double worksurface
- When a triple worksurface is specified, at least one equipment rack should be used underneath to provide adequate support
- Mid-support legs are used at the seam two worksurfaces
- End-support legs are used at the end of a worksurface

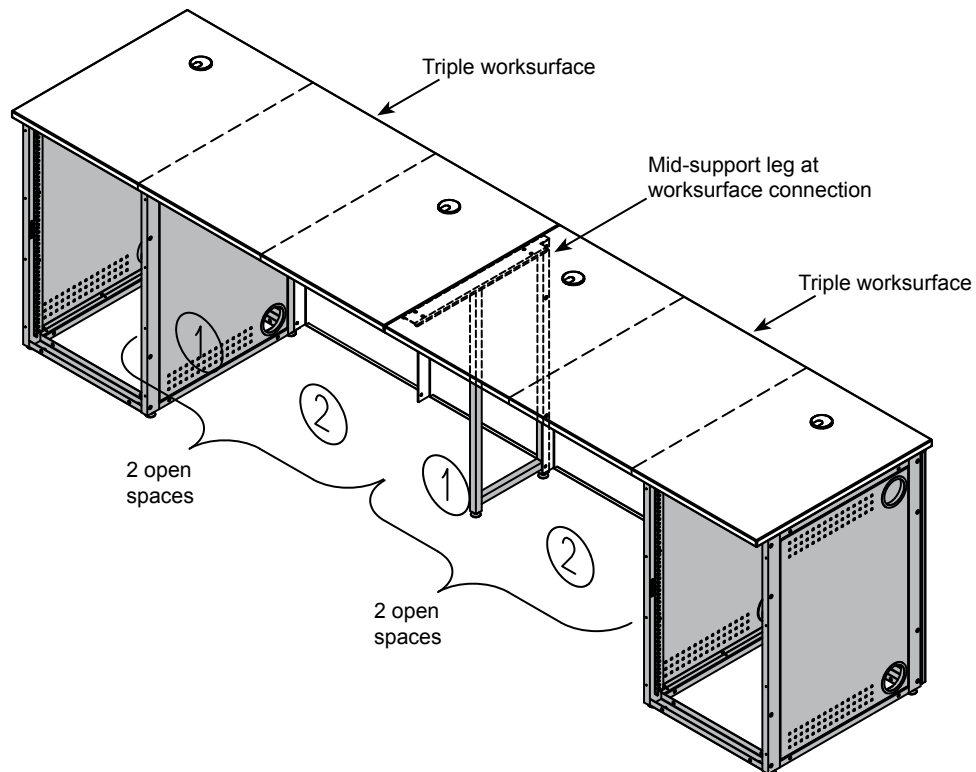
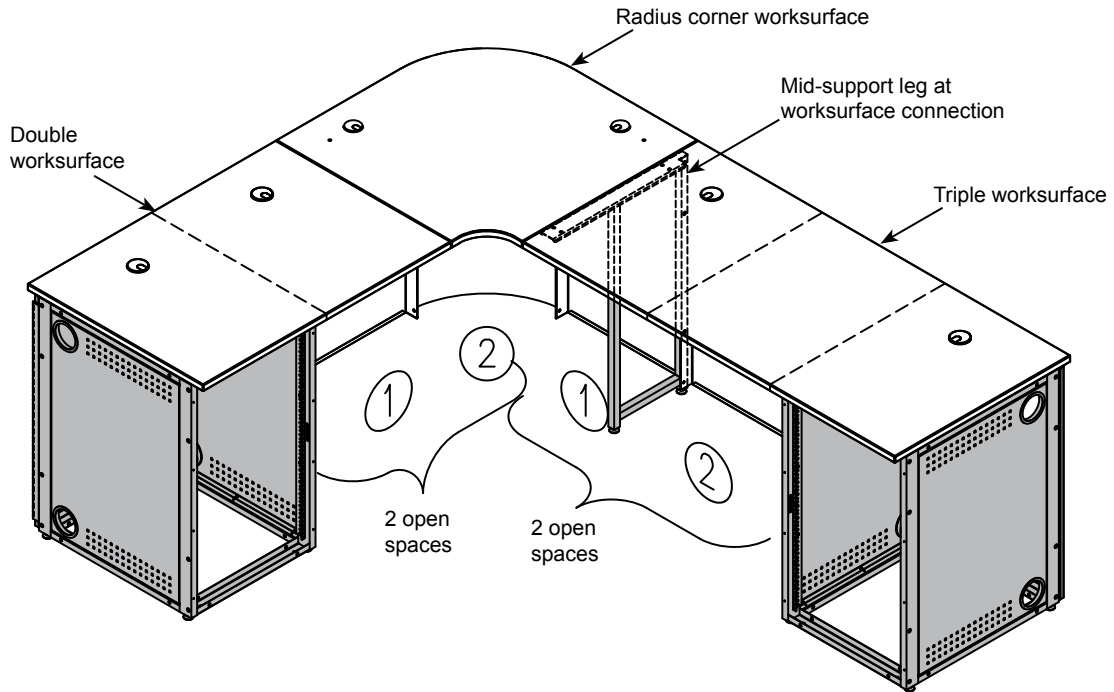

Radius Corner Assembly

1. Install the (2) glides onto the corner panel. **Figure 1A**. The glides can be adjusted later to level the console.
2. Attach each wall filler panel to the corner panel with (4) 1/4-20 x 15mm JC bolts.
3. Align and attach the corner worksurface to the wall filler panels with (4) 1/4-20 x 15mm JC bolts. **Figure 1B**.

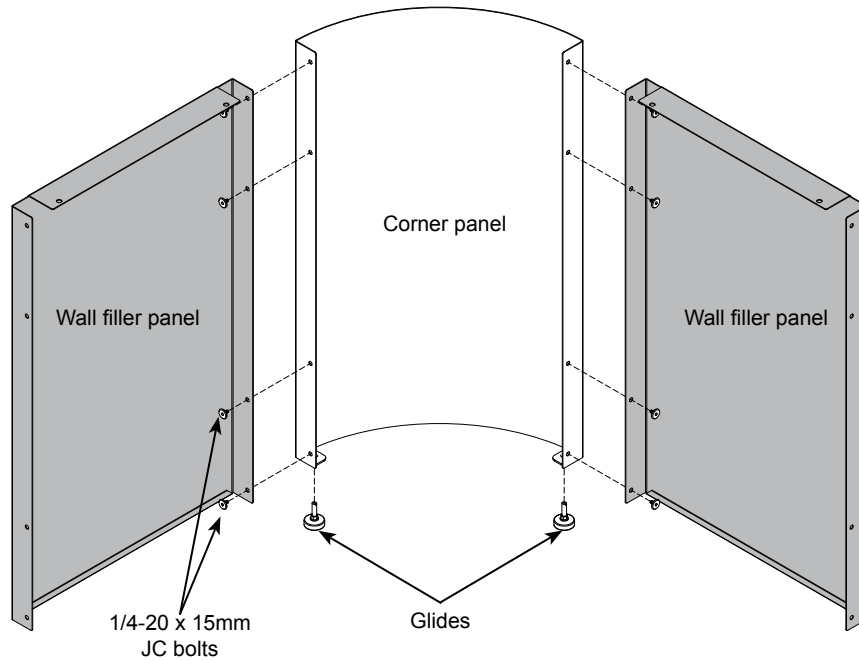

Note: Do not tighten fasteners completely until the unit is together.

Figure 1A

Note: Monitor arms can be mounted to the corner worksurface using the left or right 3/8" mounting holes.

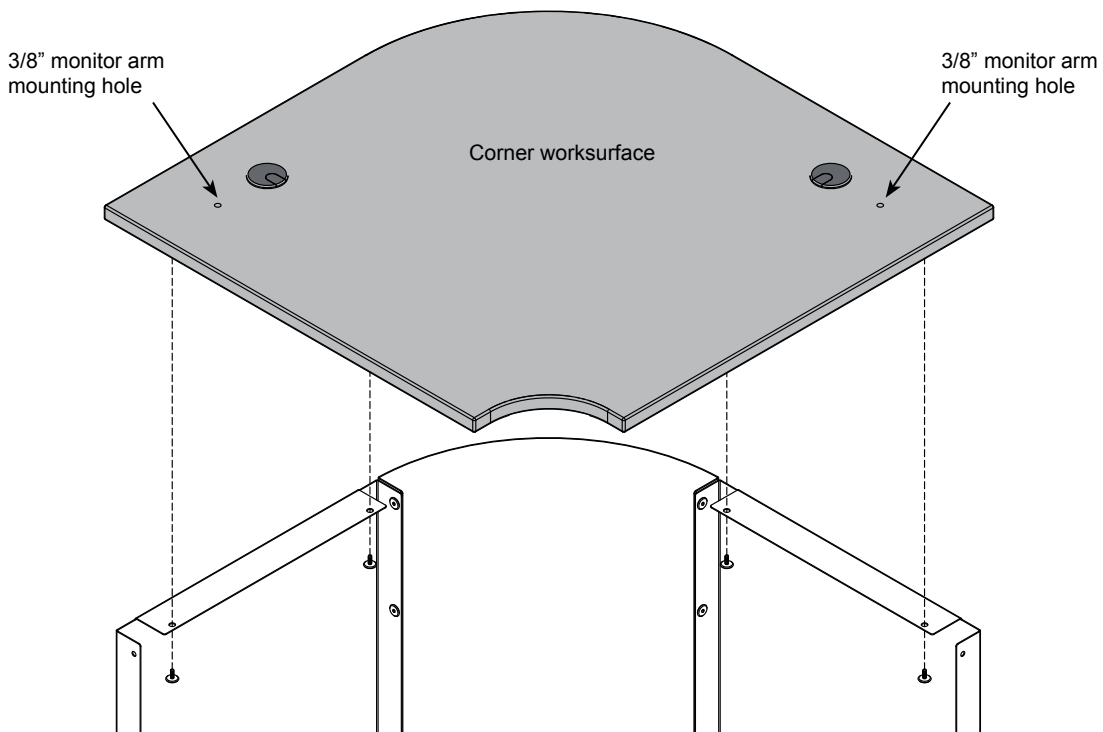

Figure 1B

Equipment Rack Assembly

1. Tip the equipment rack onto its back.
2. Install the (4) glides onto the bottom as shown. **Figure 2A**. The glides can be adjusted later to level the console.
3. Tip the unit back upright, and open the rear door to attach the (2) adhesive bumpers to the equipment rack frame as shown. **Figure 2B**.

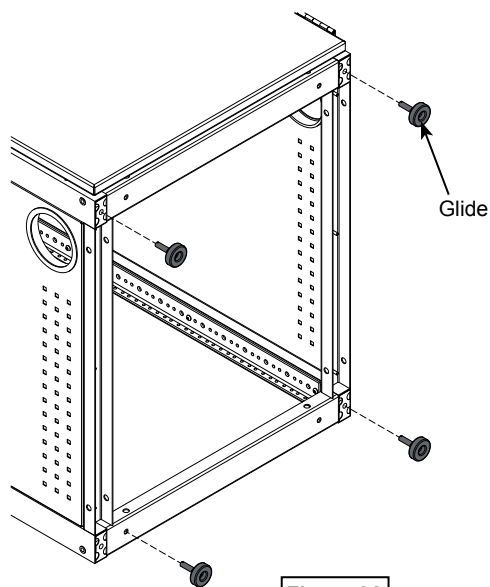

Figure 2A

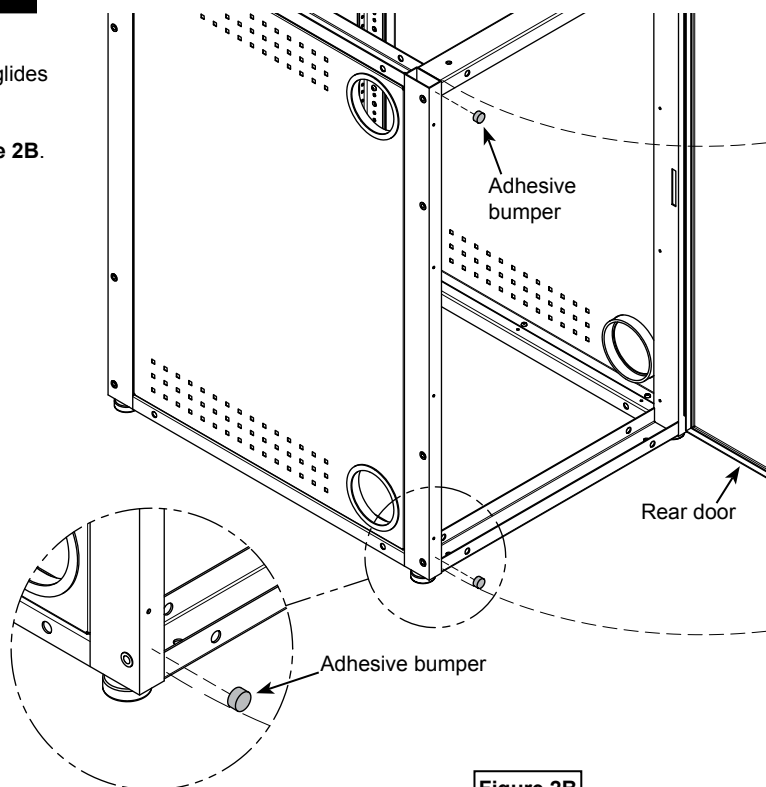

Figure 2B

Wall Filler Panel Assembly

Panel-to-Equipment Rack Attachment:

1. Align the wall filler panel mounting holes as shown. **Figure 3A**.
2. Attach with (4) 1/4-20 x 15mm JC bolts. (Locknuts not required.)

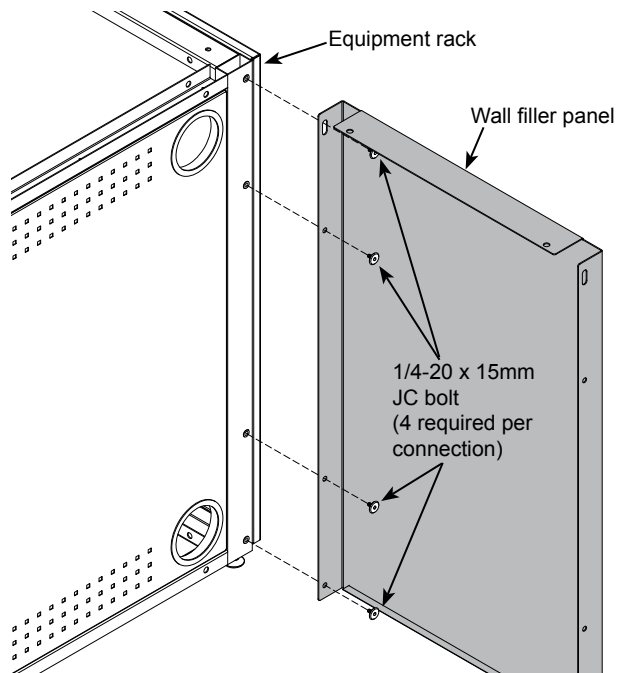

Figure 3A

Panel-to-Panel Attachment:

1. To attach two wall filler panels together, align the mounting holes.
2. Attach together with (4) 1/4-20 x 15mm JC bolts and (4) 1/4-20 flanged locknuts. **Figure 3B**.

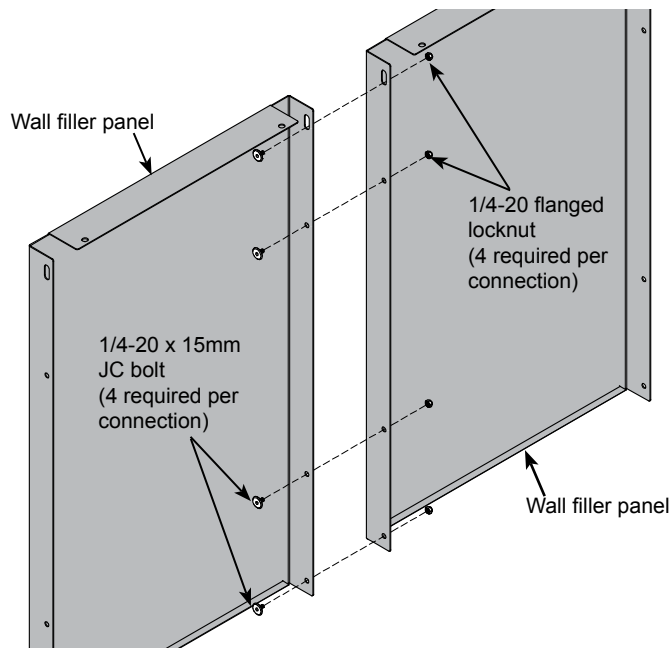
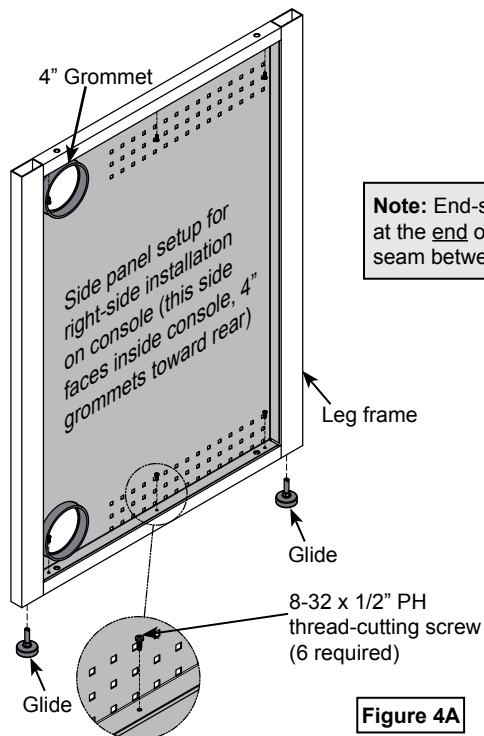

Figure 3B

Note: The two holes on top of the panel are for worksurface attachment.

End-Support Leg Assembly

1. Attach the side panel to the leg frame as shown with (6) 8-32 x 1/2" PH thread-cutting screws and tighten securely. **Figure 4A.**
Note: The 4" grommets will be at the rear of the console.
2. Install the (2) glides onto the bottom of the leg. (The glides can be adjusted later to level the console if necessary.)
3. Align the assembled end-support leg and wall filler panel mounting holes. **Figure 4B.**
Be sure the wall filler panel overlaps the end-support leg as shown.
4. Attach with (4) 1/4-20 x 15mm JC bolts.
5. Worksurface attaches to the end-support leg with (2) 1/4-20 x 40mm JC bolts.



Note: End-support legs are used only at the end of a worksurface (not on a seam between two worksurfaces).

Figure 4A

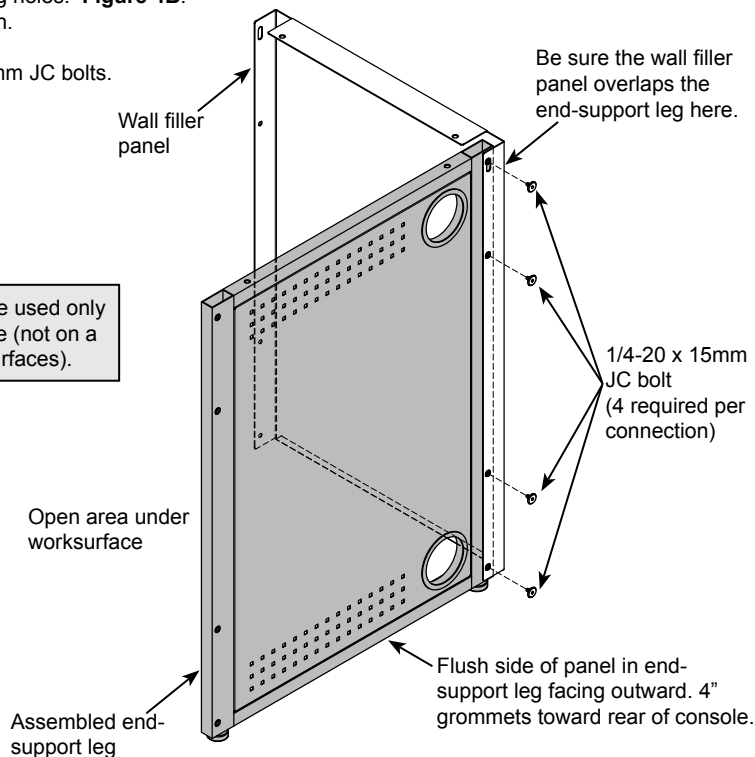

Figure 4B

Equipment Rack-to-Equipment Rack Connection

1. Place the two equipment racks together as shown. **Figure 5.**
2. Install (2) 1/4-20 x 90mm JC bolts and (2) 1/4-20 flanged locknuts.
3. Do not over-tighten fasteners.

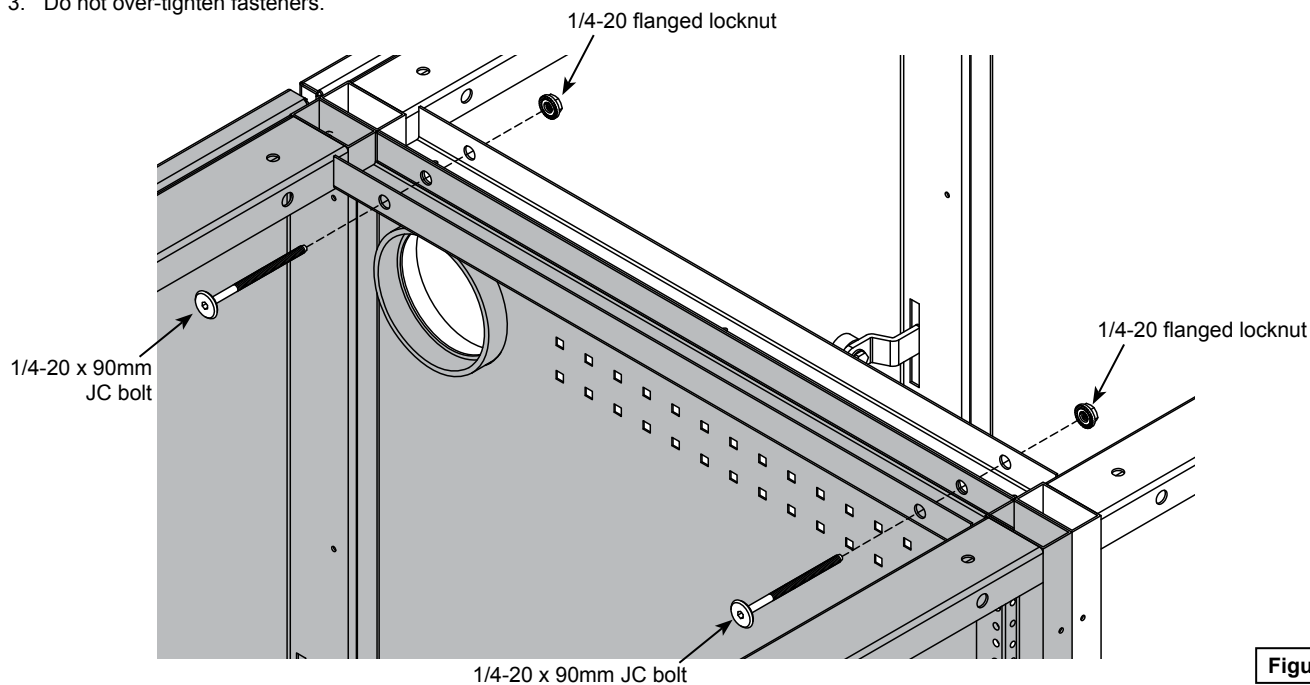

Figure 5

Mid-Support Leg Assembly

1. Install the (2) glides onto the bottom of the leg. The glides can be adjusted later to level the console.
2. Align the mid-support leg and wall filler panel mounting holes as shown. **Figure 6.**
3. Attach the mid-support leg to the wall filler panels with (4) 1/4-20 x 15mm JC bolts.
4. Set both worksurfaces onto console with the seam centered over the mid-support leg.
5. Attach to worksurfaces with (4) 1/4-20 x 15mm JC bolts

Note: Mid-support legs are used at the joint connection of two worksurfaces to provide support for two or more open spaces (or wall filler panels) wide.

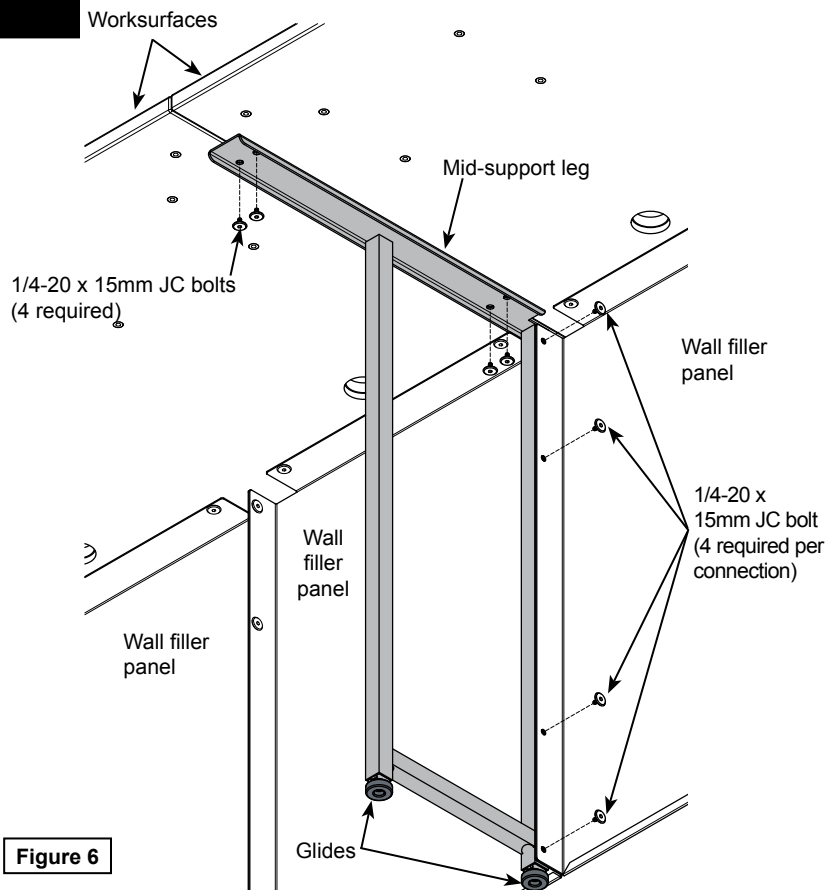

Figure 6

Worksurface Assembly

Worksurface-to-Worksurface connection:

1. Attach the (2) unit-to-unit brackets to one installed worksurface (use inner holes) with 1/4-20 x 15mm JC bolts. Do not tighten completely. **Figure 7A.**
2. Set the second worksurface onto the unit-to-unit brackets, and adjacent assembled wall filler panels.
3. Align the worksurface mounting holes with the wall filler panel mounting holes.
4. Attach with 1/4-20 x 15mm JC bolts.

Note: This is the connection between two worksurfaces with open area underneath (no equipment racks). To provide adequate support, areas under worksurfaces generally should not exceed a span of more than two open spaces (or wall filler panels) wide.

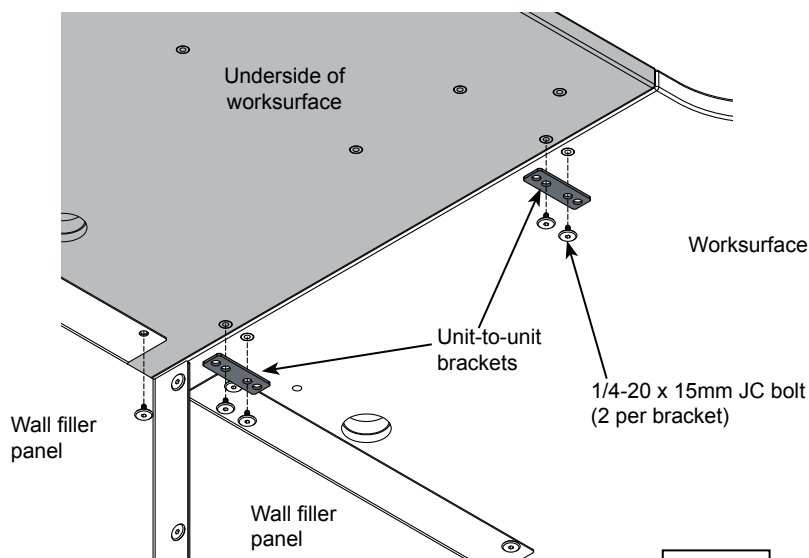

Figure 7A

Worksurface-to-top of Equipment Rack:

Note: This is the attachment of a worksurface to the top of an equipment rack.

1. Set the worksurface onto the equipment rack and any adjacent assembled wall filler panels (if applicable). **Figure 7B.**
2. Align the worksurface and equipment rack mounting holes.
3. Attach worksurface with (4) 1/4-20 x 15mm JC bolts.

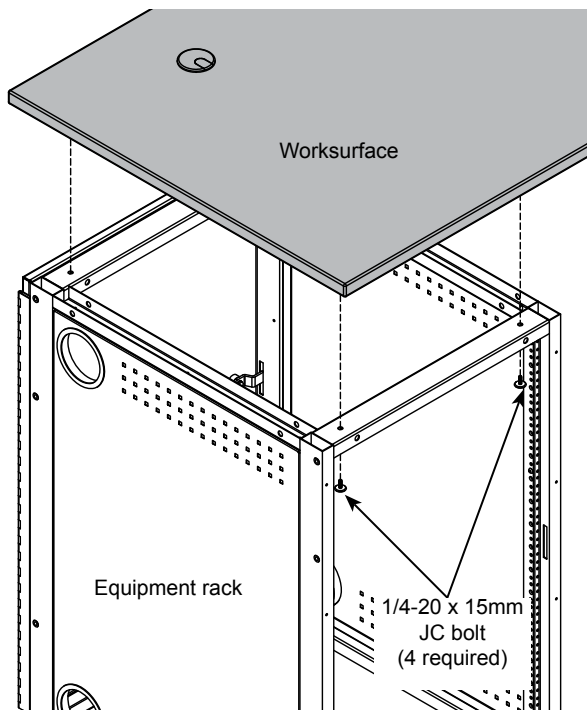

Figure 7B

Worksurface-to-Worksurface with Equipment Rack:

Note: This is the connection between a worksurface of equal height to another worksurface above an equipment rack.

1. Attach each worksurface bracket to the equipment rack with (1) 1/4-20 x 50mm JC bolt and (1) 1/4-20 serrated flanged locknut (*attached from inside eq rack*). (The slotted side of the bracket will attach to the worksurface.) Do not tighten completely. **Figure 7C.**
2. Set the worksurface onto the assembled wall filler panel(s) and worksurface brackets and align the mounting holes.
3. Attach worksurface with 1/4-20 x 15mm JC bolts.
4. Align the tops of the worksurfaces and tighten all screws securely.

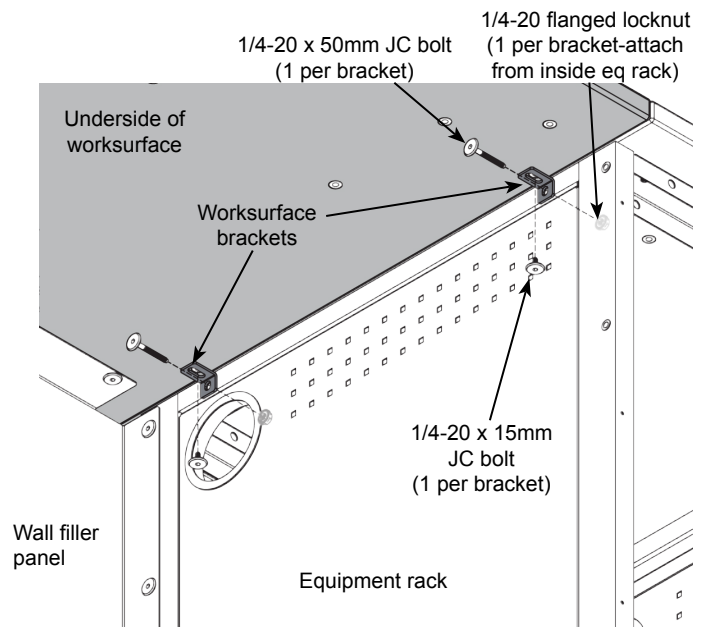

Figure 7C

Cord Clips

1. Apply cord clips to underside of worksurface where needed to route and secure cords. **Figure 8.**

(Clips only included with radius corner and wall filler panels.)

Note: The cord clips provide cord management when cords and wires are to be routed to the worksurface from under the console.

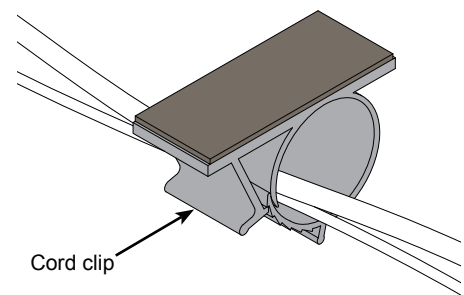
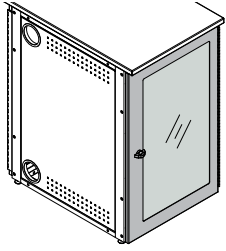

Figure 8

Accessories



Clear Acrylic Locking Door
36"H - 68153
29"H - 68103

- For instructor-side installation
- Can be installed to be hinged from the left or right side

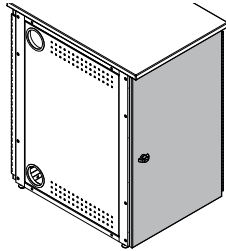

Solid Locking Door
36"H - 68152
29"H - 68102

- For instructor-side installation
- Can be installed to be hinged from the left or right side

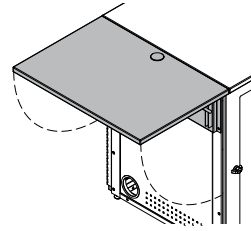

Not for use on end-support legs or stand-alone equipment racks

Flip-up Shelf - 68204

- Shelf hinges lock into place in the upright position
- Shelf mounts level with worksurface
- Includes 2" grommet
- Mounting plate available in black or dark gray

Weight capacity: 35 lb [15.9 kg]
Dimensions: 21.1875"W [53.8 cm] x 30"D [76.2 cm] x 1"H [2.54 cm]
Unit weight: N/A

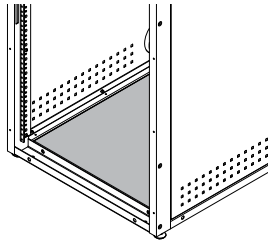

Equipment Rack Bottom Shelf - 68203

- Increases security
- Prevents static electricity and dust build-up
- Includes 4" grommet at back

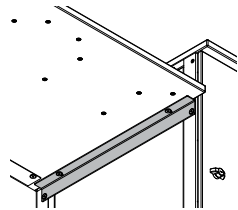

Stepped-Height Bracket - 68205

- Connects 29"H console to 36"H console

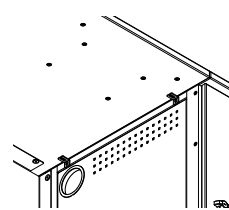

Level-Height Bracket Kit - 68207

- Attaches a worksurface to another worksurface of equal height over an equipment rack

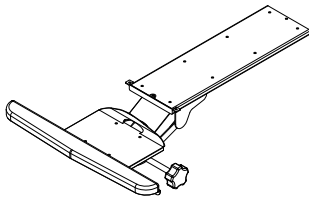

Econo Keyboard Tray - 95520

- 18.375"W [46.7 cm] x 12"D [30.5 cm]

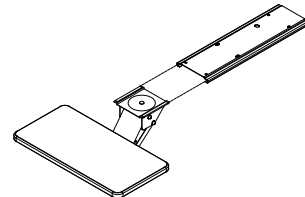

Micro-Arm Keyboard Tray - 95506

- Slides in, out, up and down
- 19.75"W x 10"D

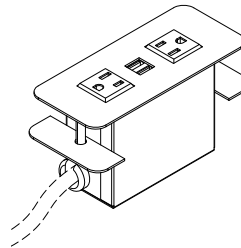

Cove Power Module - 99044

- Two power receptacles per module
- Two USB charge ports (not data-compatible)
- Thumbscrew clamps
- Requires worksurface cutout
- ETL listed
- Available in Black or Silver



Cutout required: 5.25"W [13.3 cm] x 2"D [5.1 cm] (mounts to surface thicknesses up to 1.5")

Power cord: 9' [274 cm] with 90° flat plug with 45° rotation

Power receptacles: 12A, 120 VAC spill-resistant

USB charging ports: 2.1A (10.5W)

Dimensions: 6"W [15.2 cm] x 2.5"D [6.35 cm] x 3.18"H [8.1 cm]

Unit weight: 2.29 lb [1 kg]

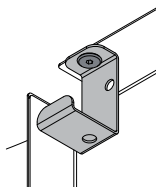

Wire Management Clips - 68206

- Mounts under worksurface
- Set of 3



Rear Rack Rail Kit
36"H - 68150
29"H - 68100

- Adds 18RU or 14RU to rear of equipment rack
- Set of 2

Warranty

WE WILL MAKE IT RIGHT FOR YOU!

Spectrum is committed to provide complete customer satisfaction. Each of our products is manufactured from the best materials available and each product is stringently monitored throughout the production process through our P.A.C.E. program (Product Assurance to meet Customer Expectations).

We expressly warrant that Spectrum products will be of good quality and workmanship and free from defect for the period set out in the warranty table below from the date of delivery. This warranty shall not apply to defects or damage resulting from misuse, abuse, neglect, improper care, modification or repair not authorized by Spectrum, or any other cause outside the control of Spectrum. Spectrum will, at its sole option, either repair or replace the defective product.

This warranty is exclusive; no other warranty, written or oral, is expressed or implied. This warranty is given by Spectrum to Buyer and to no other person or legal entity. No Spectrum dealer, distributor, agent or employee is authorized to make any modification or addition to this warranty.

NOTWITHSTANDING ANYTHING TO THE CONTRARY, SPECTRUM WILL NOT UNDER ANY CIRCUMSTANCES BE LIABLE FOR INDIRECT OR LIQUIDATED DAMAGES, INCLUDING CONSEQUENTIAL, INCIDENTAL AND SPECIAL DAMAGES. IN NO EVENT SHALL SPECTRUM'S LIABILITY, WHETHER UNDER CONTRACT OR WARRANTY, IN TORT OR OTHERWISE, EXCEED THE PURCHASE PRICE RECEIVED BY SPECTRUM FOR THE PRODUCT AT ISSUE AND "RECALL ACTION" EXPENSES. SPECTRUM SHALL NOT BE SUBJECT TO ANY OTHER OBLIGATIONS OR LIABILITIES, WHETHER ARISING OUT OF BREACH OF CONTRACT, WARRANTY, TORT (INCLUDING NEGLIGENCE AND STRICT LIABILITY) OR OTHER THEORIES OF LAW, WITH RESPECT TO PRODUCTS SOLD OR SERVICES RENDERED BY SPECTRUM, OR ANY UNDERTAKINGS, ACTS OR OMISSIONS RELATING THERETO.

Our Customer Service Department is ready to provide immediate attention to any questions, comments or concerns. They are available to answer your calls Monday through Friday from 7 am to 5 pm CST. In addition your product comments or concerns are welcome via e-mail at: spectrum@spectrumfurniture.com.

Warranty Table

Item	Warranty Period effective 1/1/2015
Adjustable Crank / Electric Desk Legs	• 1 Year
Flat Panel Desk Gas Cylinders	
Chairs <ul style="list-style-type: none"> • Adjustable Height Chair Parts – including frames, gas cylinders, wood and plastic parts, control handles, casters • Adjustable Height Chair Upholstery • In-Stock Upholstery • Graded-In Fabrics and Customer Owned Material 	<ul style="list-style-type: none"> • 7 Years • 2 Years • 2 Years • No Warranty
Height Adjustable Columns and Lifts	• 1 Year
General Use Casters	
Electrical (including timers and LINAK actuators)	• 2 Years
Keyboard / Mouse Trays	• 1 Year
Flat Panel Monitor Arms <ul style="list-style-type: none"> • Flat Panel Monitor Arm – General Parts • Flat Panel Monitor Arm – Gas Cylinders 	<ul style="list-style-type: none"> • 5 Years • 2 Years
Desks and Lecterns <ul style="list-style-type: none"> • Computer Desk Chassis • Cart Chassis • Lectern Chassis 	• 10 Years

