

Assembly Instructions

⚠ Important ⚠

Before you begin, read and comply with all safety and operating instructions, and ensure all parts and correct quantities are included.

Any parts damaged during shipment must be reported within 5 days of receipt. To report information regarding missing parts or damage, to purchase parts or accessories, or if you have any questions, please contact us.

www.spectrumfurniture.com
800-235-1262, 715-723-6750

Thank you for purchasing Spectrum products!

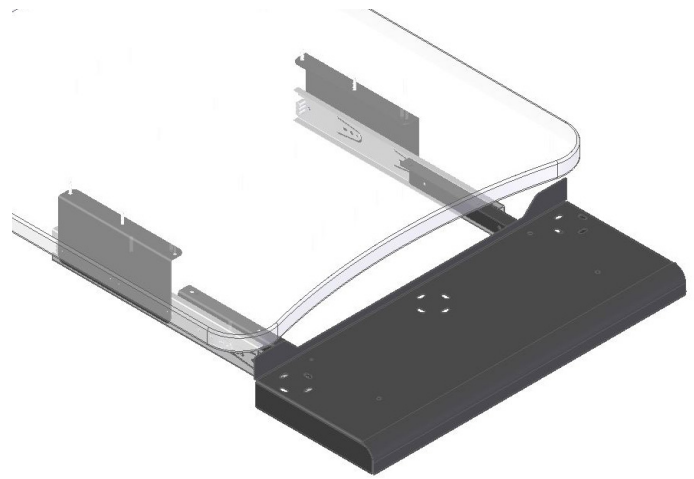

Inspiration Keyboard Tray 95538

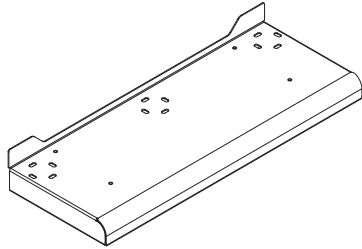

(1) 0141715
Keyboard Tray

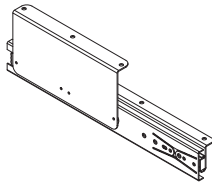
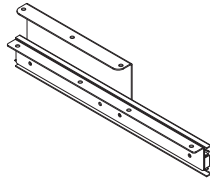

Left and Right slide assemblies
consisting of:

- (1pr) 0114747 14" Slide set
- (2) 0141718 Keyboard bracket
- (2) 0141728 Slide bracket

Tools
Required



(6) 026073
#8 x 3/4" PHSM



(4) 021588
8-32 Keps nut

1. Attach slide assemblies to worksurface

1. Open the lectern instructor-side door (if equipped).
2. Extend the slides.
3. Align and attach each slide assembly to the worksurface using (3) #8 x 3/4" PHSM screws. **Figure 1.** (Note left and right orientation).
4. Tighten screws securely.

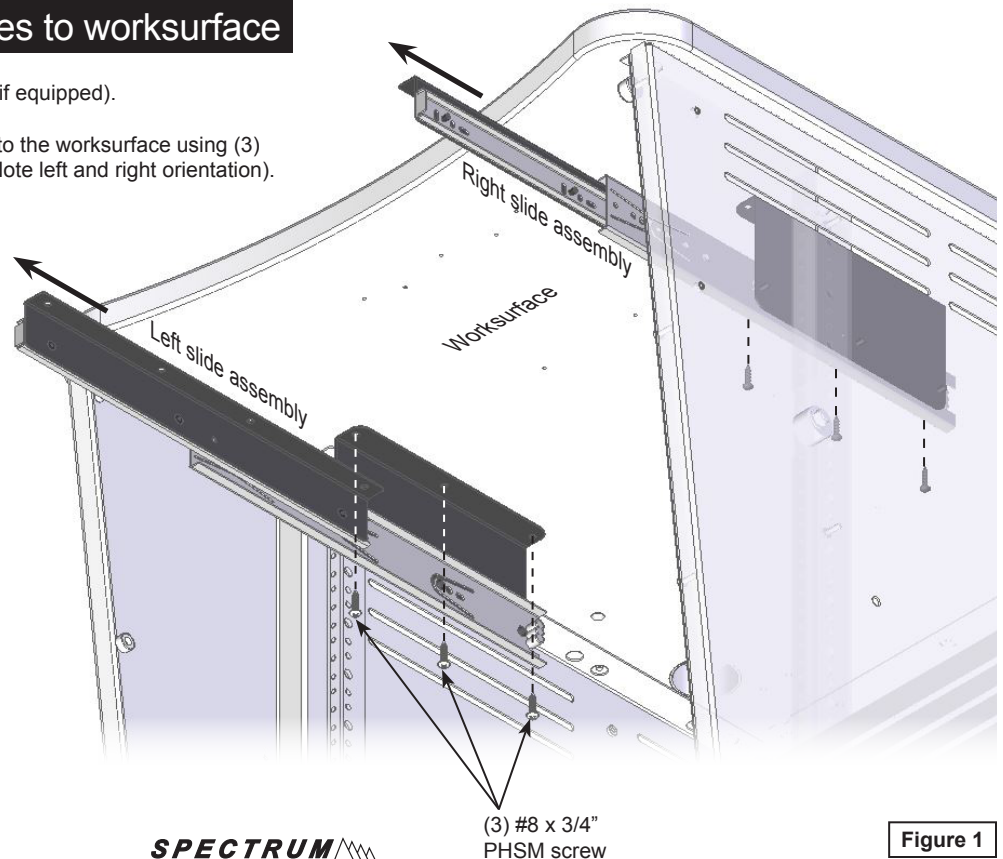

2. Attach keyboard tray to slides

1. Place the keyboard tray onto the extended slides and align studs with mounting holes.
2. Install (1) 8-32 Keps nut on each stud to secure. **Figure 2.**
3. Tighten Keps nuts securely.

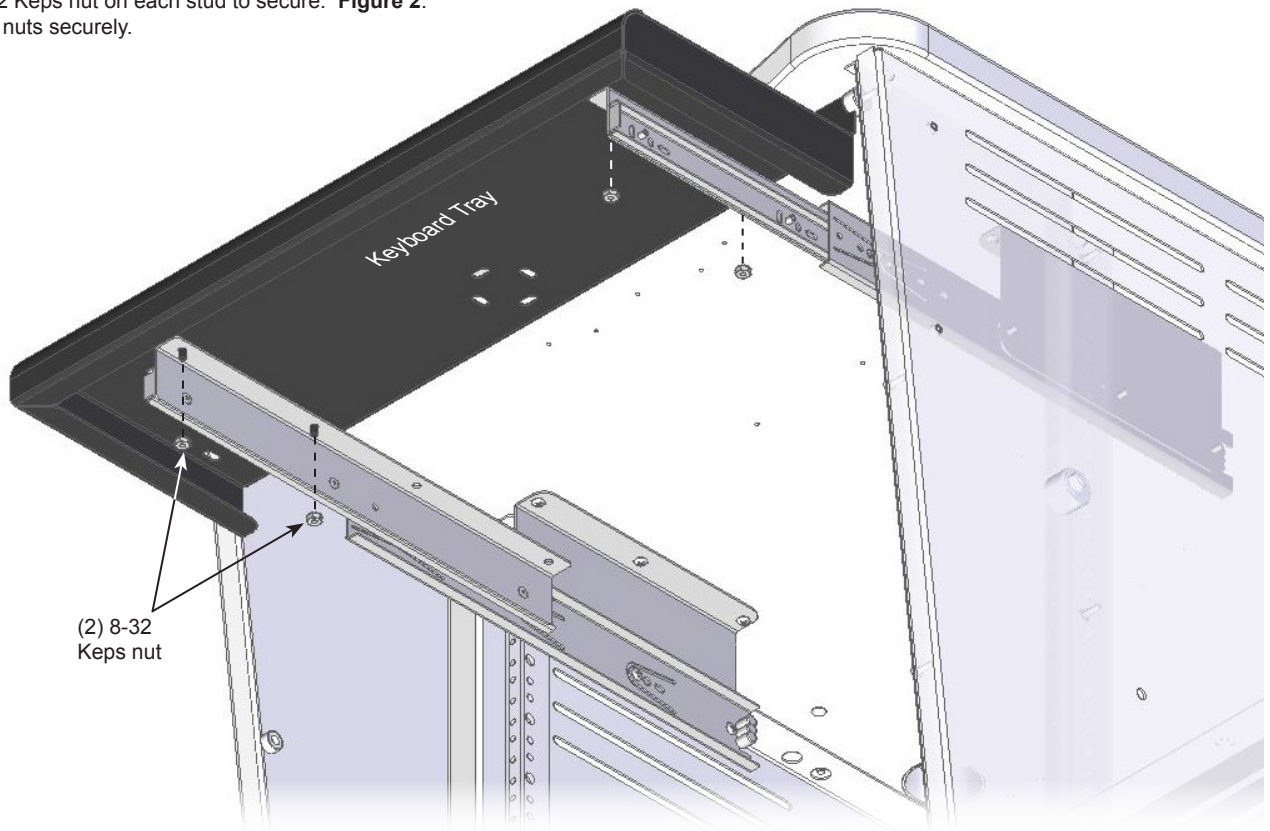

Figure 2

Releasing keyboard tray slides

1. To flip, pull the tray out fully and locate the plastic lever on each slide. **Figure 3.**
2. Release the levers on the both slides while pulling the tray out.

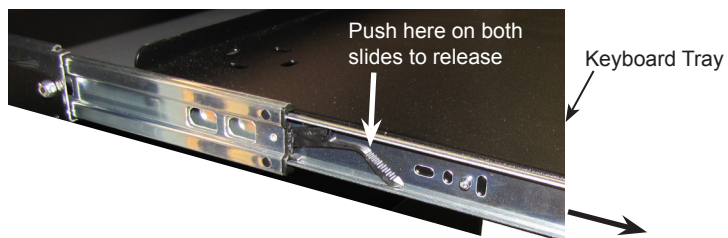

Figure 3