

## Technical Specifications

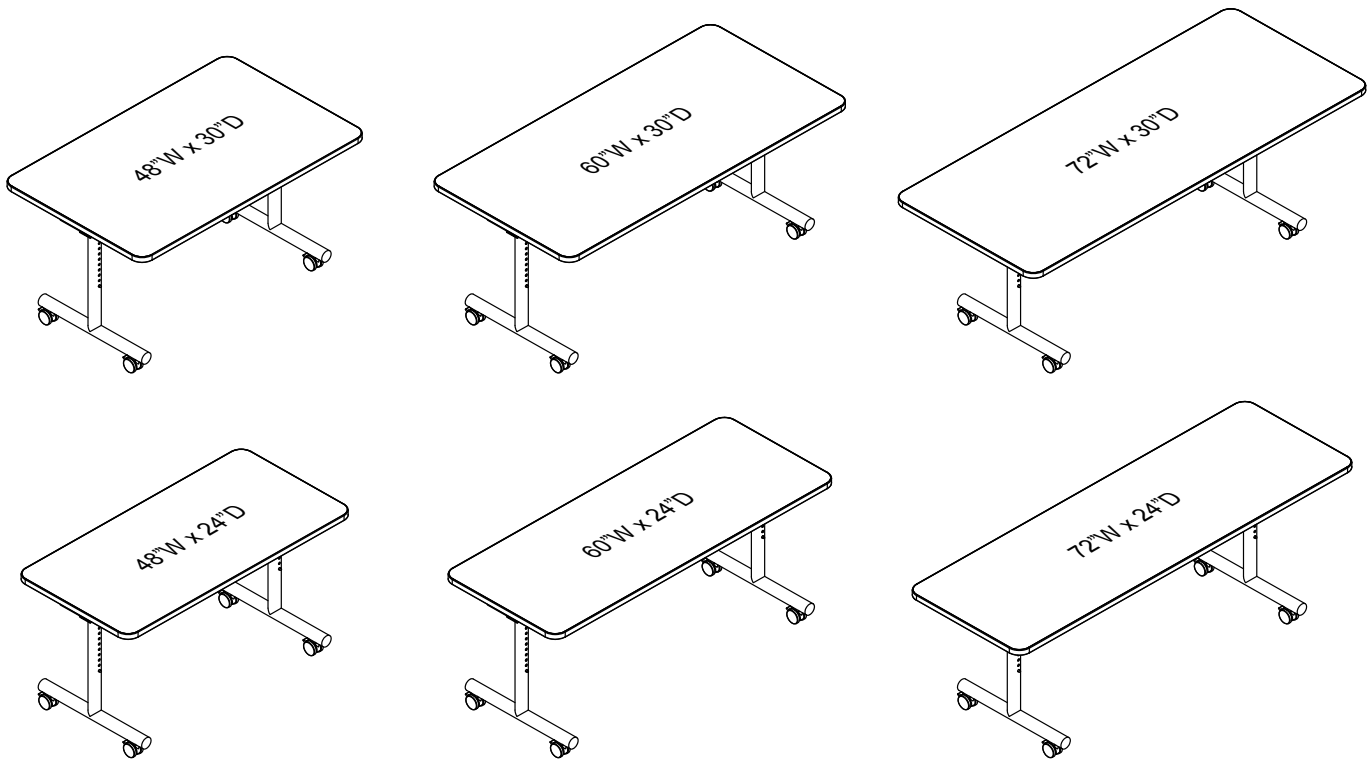

Spectrum's Flex Flip Tables were designed with room reconfiguration in mind. The flip-up design frees up valuable space while the casters provide quick and easy reconfiguring of any room. These durable, all-purpose collaborative/training tables are designed for use in a wide variety of applications such as training/conference rooms, mailrooms, classrooms, and computer labs.

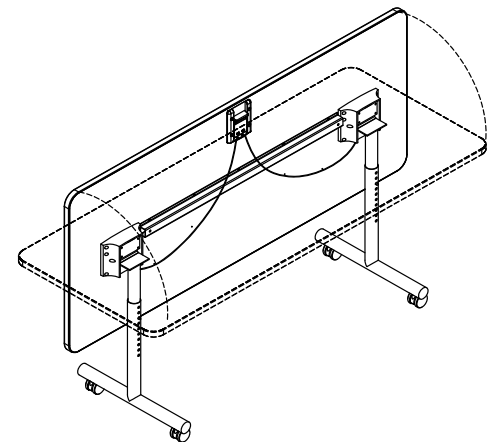

## Features and Benefits

- Flip-up worksurfaces allow tables to be moved and nested together to save space when not in use
- Scratch and impact-resistant high-pressure laminate worksurface
- Durable powder coated steel legs provides a long-lasting finish
- Four 2.375" locking casters make it easy to rearrange room configurations
- Available in 72", 60", and 48" wide versions
- Available in 30" or 24" depths (24" depth is ideal for laptop use or when space is limited)
- Height-adjustable legs allow table to be configured to a wide variety of users and situations
- Worksurface brace provides support and minimizes flexing (all sizes)
- Matching vinyl color edge trim on worksurface edges protects walls and furniture (some laminate choices use non-matching edge trim)
- Four 2.375" locking casters provide easy rolling, and make it easy to rearrange room configurations
- Optional Cove power module (requires worksurface cutout) and wire management kit available
- Standard laminate colors available to match existing furniture
- Table ships "knocked-down" for lower shipping costs and can be easily assembled at the final location
- Warranted to be free of all defects in materials and workmanship for 10 years
- Designed and assembled in Chippewa Falls, WI, USA

### Flex Flip Table configurations available:

1. Table only
2. Table, cord tray, Cove module, and cutout
3. Table, Easy Power Connection Kit, Cove module, and cutout

Note: The color of the Flex Flip table legs may not be an exact match with other Spectrum color powder coat offerings.

### Color Options

See [spectrumfurniture.com](http://spectrumfurniture.com) for complete color options and combinations.

# Construction

- The worksurface is constructed from 1" thick NAF (no added formaldehyde) composite board with .030" [.762mm] high-pressure laminate on one face, and a balancing phenolic backer on the opposing face
- Worksurface edges are covered with vinyl edgeband
- The formed worksurface brace is 14-gauge steel
- All metal components are finished with a scratch-resistant powder coat epoxy
- All tables are shipped knocked-down (KD) and require assembly

# Specifications

Sizes available	24"D	30"D
	48"W [121.92 cm] x 24"D [61 cm]	48"W [121.92 cm] x 30"D [76.2 cm]
	60"W [152.4 cm] x 24"D [61 cm]	60"W [152.4 cm] x 30"D [76.2 cm]
	72"W [182.88 cm] x 24"D [61 cm]	72"W [182.88 cm] x 30"D [76.2 cm]
Adjustable height	25.625"H [65.09 cm] - 34.625"H [87.95 cm] in 1" increments	
Casters	Weight capacity 100 lb [45.4 kg] each	
Seating	48"W - 1 person 60"W - 2 people 72"W - 2 people	
ADA-compliance*	1 ADA seat per table (Legs must be extended to clear 27" minimum knee height) <small>*Minimum ADA guidelines for knee clearances are 30"W x 19"D x 27"H</small>	
Certifications / Compliance	<ul style="list-style-type: none"> <li>• SCS Indoor Advantage Certified</li> <li>• TAA compliant</li> <li>• Meets or exceeds applicable ANSI-BIFMA test standards</li> </ul>	
Unit weight (nominal)	53 lb [24.1 kg] - 48"W x 24"D 64 lb [29.1 kg] - 60"W x 24"D 75 lb [34.1 kg] - 72"W x 24"D	64 lb [29.1 kg] - 48"W x 30"D 75 lb [34.1 kg] - 60"W x 30"D 86 lb [39.0 kg] - 72"W x 30"D
Shipping weight (nominal)	77 lb [35 kg] - 48"W x 24"D 88 lb [40 kg] - 60"W x 24"D 99 lb [45 kg] - 72"W x 24"D	88 lb [40 kg] - 48"W x 30"D 99 lb [45 kg] - 60"W x 30"D 110 lb [50 kg] - 72"W x 30"D

Specifications subject to change without notice

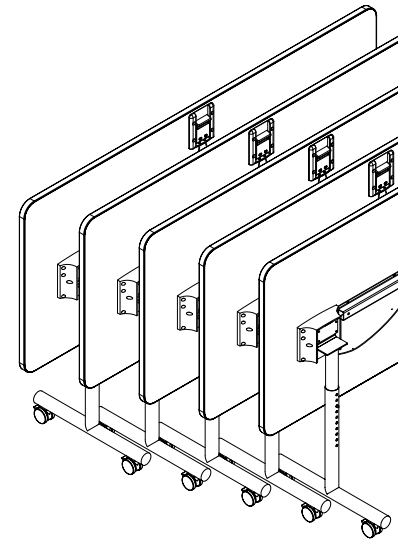

Tables shown nested in storage



Casters

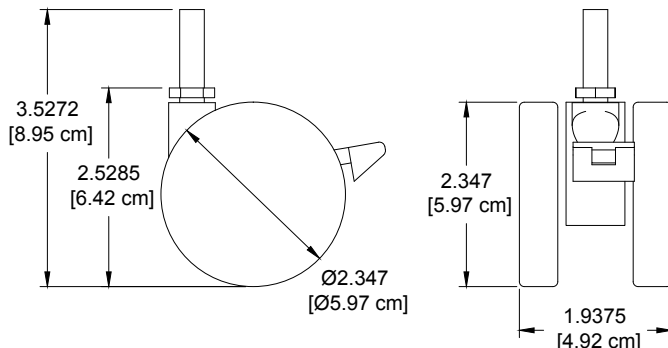
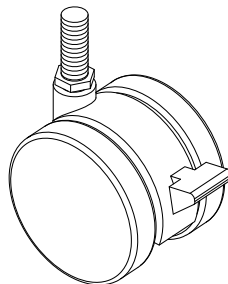

Spring button on each leg provides 9" of height adjustment in 1" increments

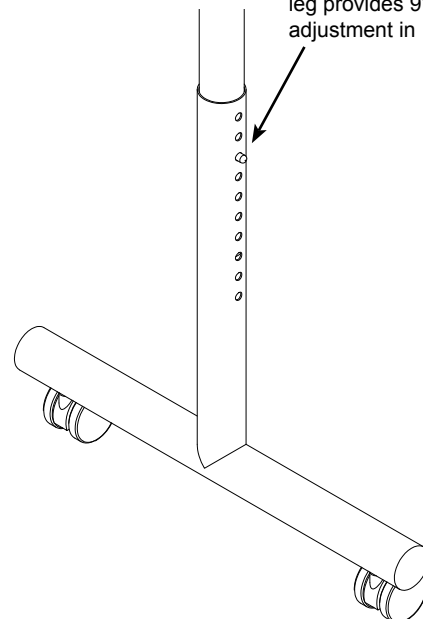

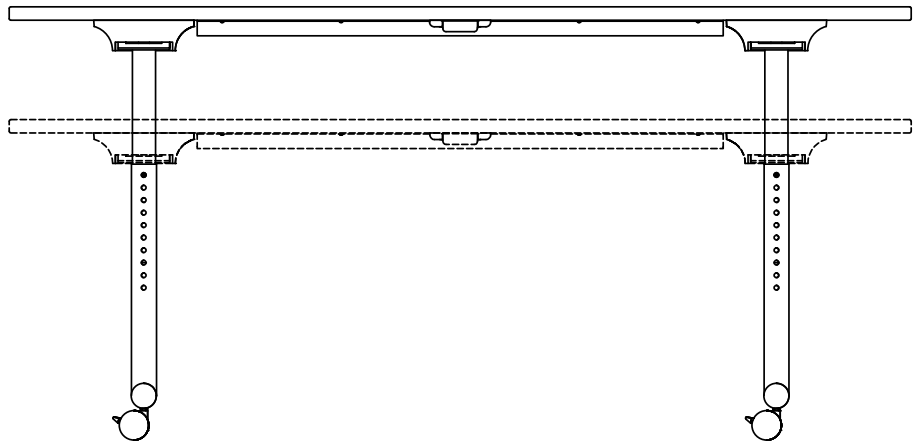
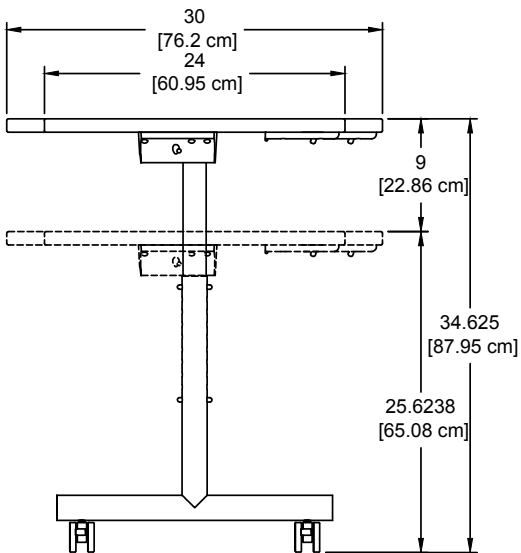
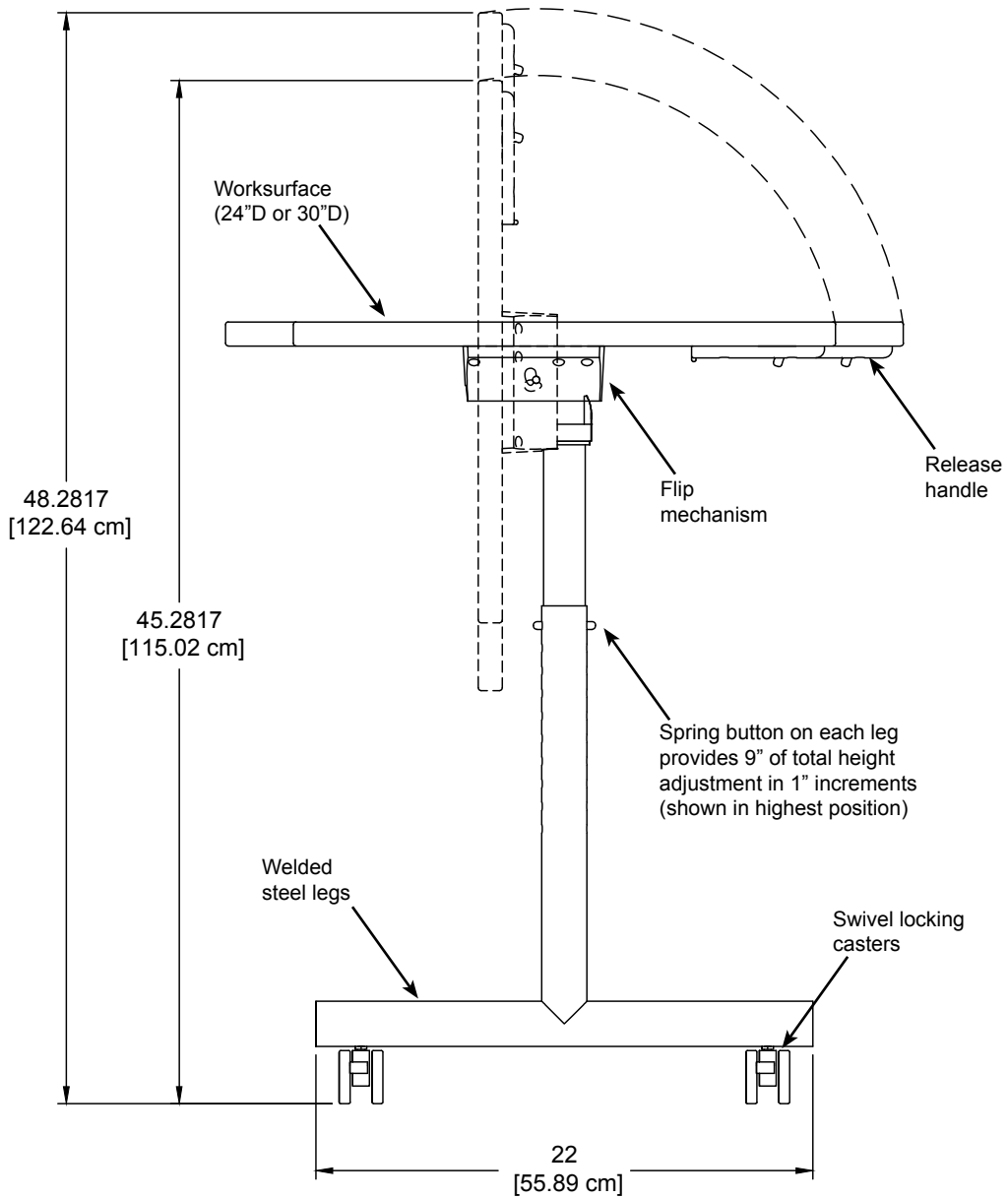

ORDER CODE 4830 = 48"W x 30"D

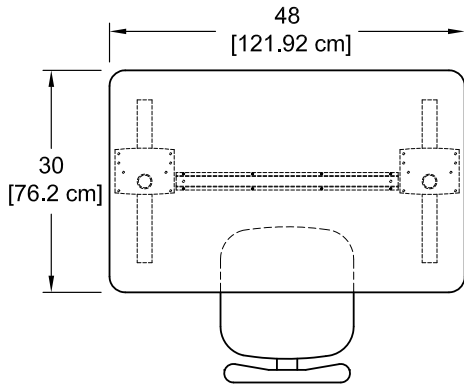

ORDER CODE 4824 = 48"W x 24"D

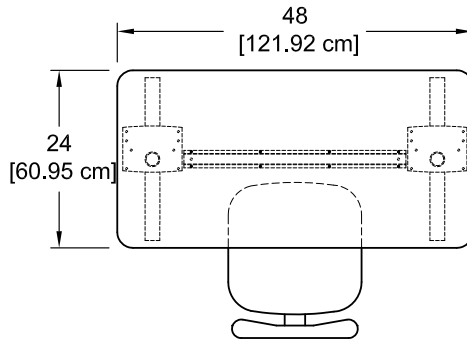

ORDER CODE 6030 = 60"W x 30"D

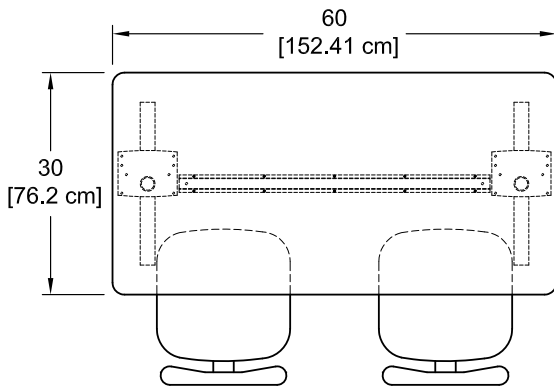

ORDER CODE 6024 = 60"W x 24"D

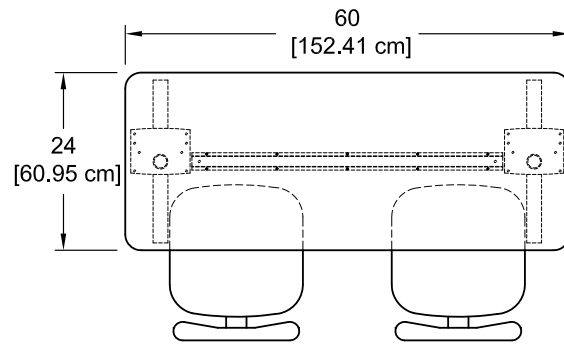

ORDER CODE 7230 = 72"W x 30"D

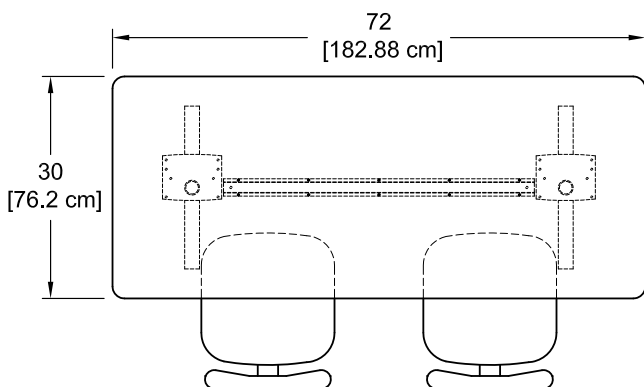

ORDER CODE 7224 = 72"W x 24"D

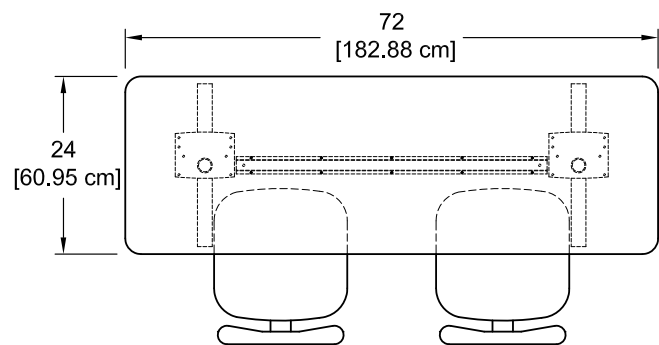

<b>ORDER CODE 0 =</b>	None
<b>ORDER CODE 3 =</b>	Silver Cove Module
<b>ORDER CODE 4 =</b>	Black Cove Module

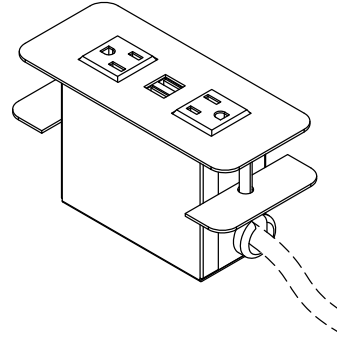

**Cove™ Power Module**

- Two AC power receptacles
- Two USB charge ports (not data-compatible)
- Thumbscrew clamps
- Requires worksurface cutout
- 9' AC power cord
- ETL listed
- Available in Black or Silver

Cutout required:	5.25"W [13.3 cm] x 2"D [5.1 cm]
Power cord:	9' [274 cm] with 90° flat plug with 45° rotation
Power receptacles:	12A, 120 VAC spill-resistant
USB charging ports:	2.1A (10.5W)
Dimensions:	6"W [15.2 cm] x 2.5"D [6.35 cm] x 3.18"H [8.1 cm]
Unit weight:	2.29 lb [1 kg]

Cove Module available in Black or Silver

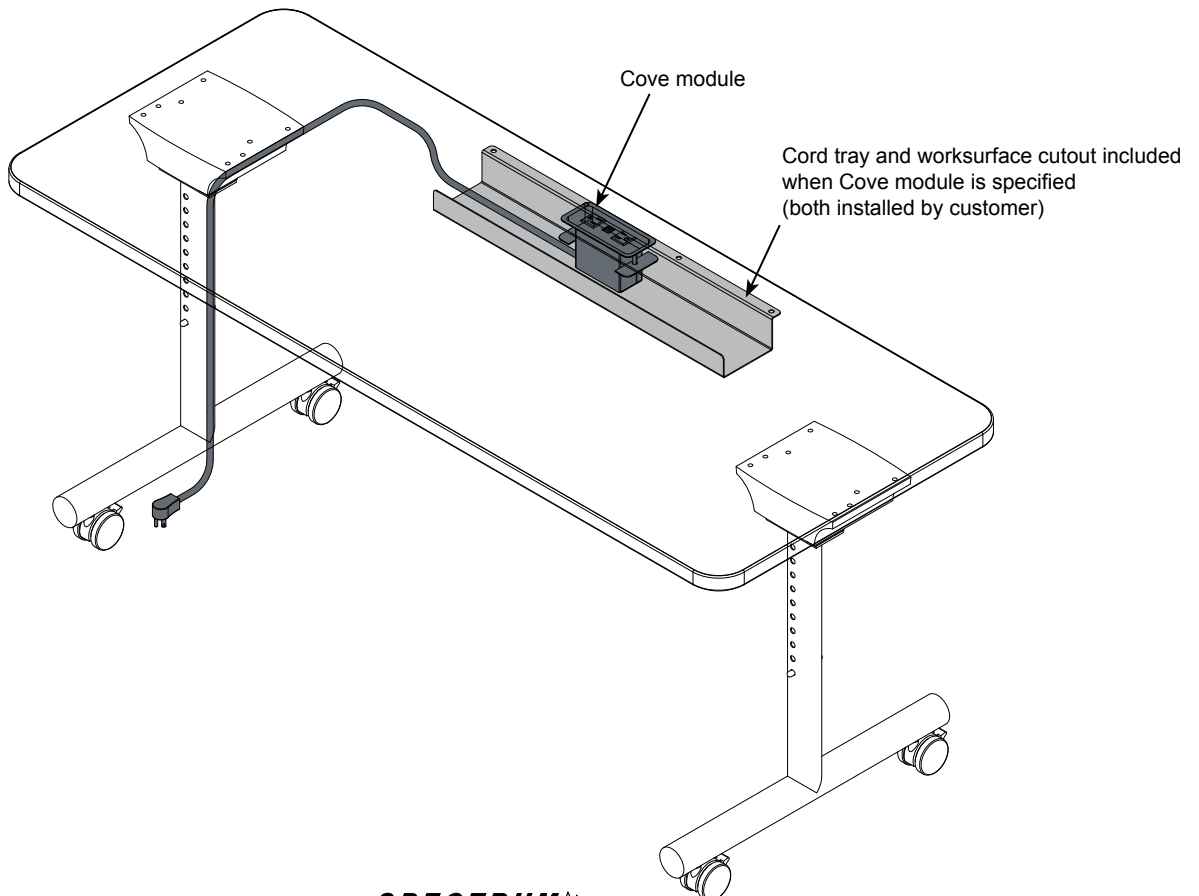

Easy Power Connection Kit with Cove™ Power Module

<b>ORDER CODE 5 =</b>	Easy Power Connection Kit - Black Cove Module
<b>ORDER CODE 6 =</b>	Easy Power Connection Kit - Silver Cove Module

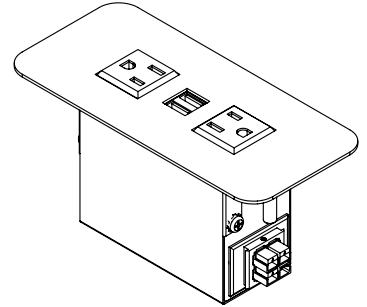
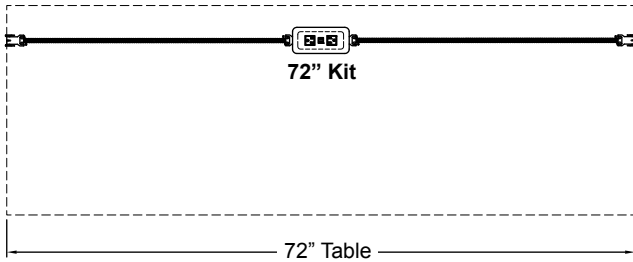
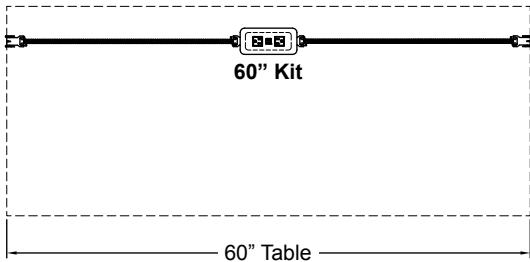
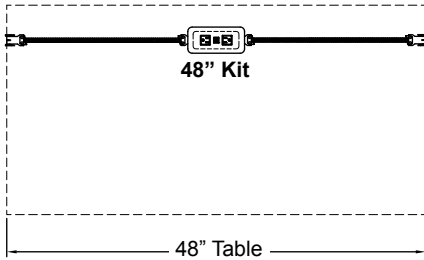

- Each table accommodates one power connection kit
- Two AC power receptacles
- Two USB charge ports (not data-compatible)
- Worksurface includes 5.25"W x 2"D worksurface cutout
- Flexible metal conduit is secured to worksurface underside
- Cove is ETL listed
- Thumbscrew clamps
- Cove available in Black or Silver
- Starter connects to standard 3-prong wall outlet

Cutout required:	5.25"W [13.3 cm] x 2"D [5.1 cm]
Power cord:	15A
Power receptacles:	12A, 120 VAC spill-resistant (2 receptacles)
USB charging ports:	2.1A (10.5W) (2 USB charging ports)
Cove dimensions:	6"W [15.2 cm] x 2.5"D [6.35 cm] x 3.18"H [8.1 cm]

- Each table accommodates one power connection kit
- Each row also requires one 99050 starter-order separately
- Typical installations do not exceed 6 or 7 Easy Power Connection Kits (or tables) per row (or circuit).

Cove Module available in Black or Silver



Worksurface cutout required

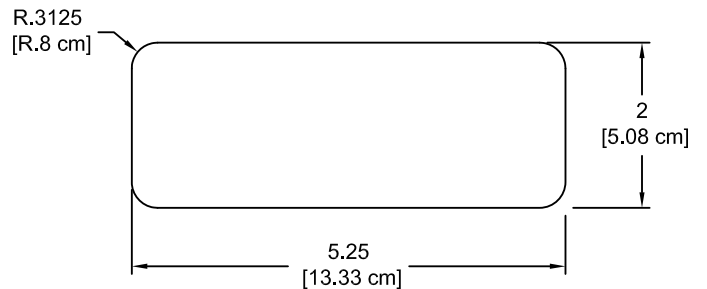

**99050 - Starter Kit**  
(One per row required)  
includes 20-15A adapter cord

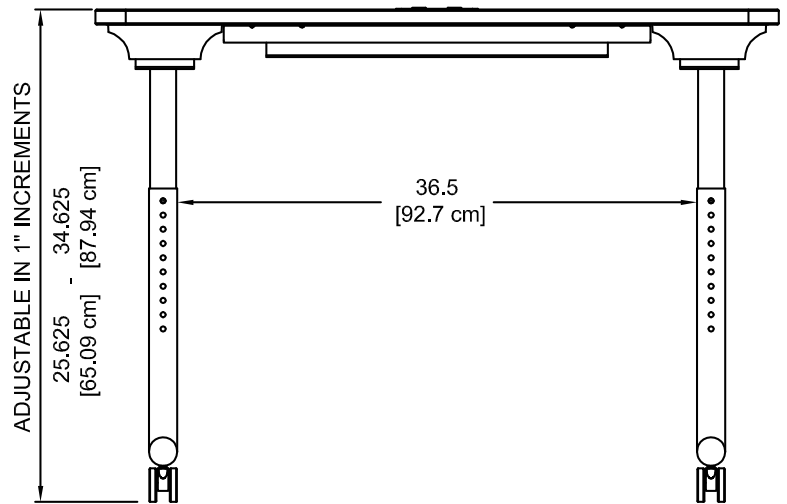
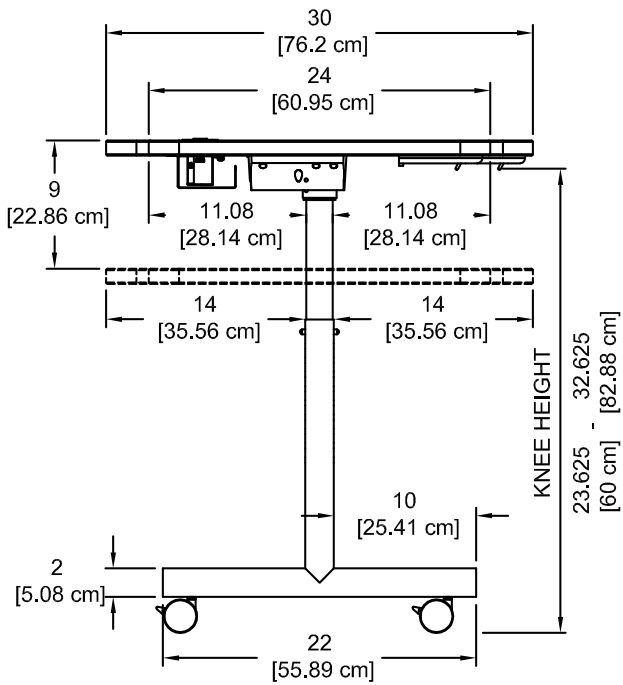
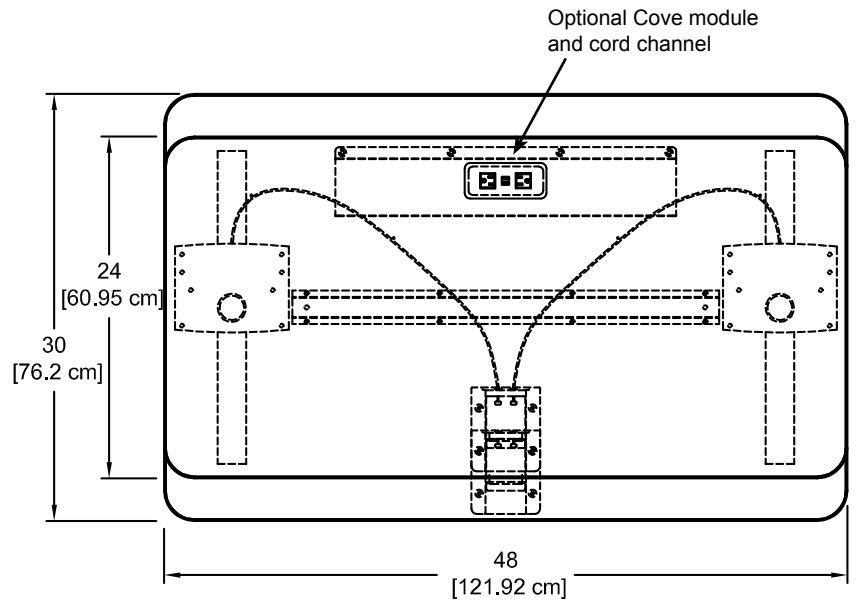
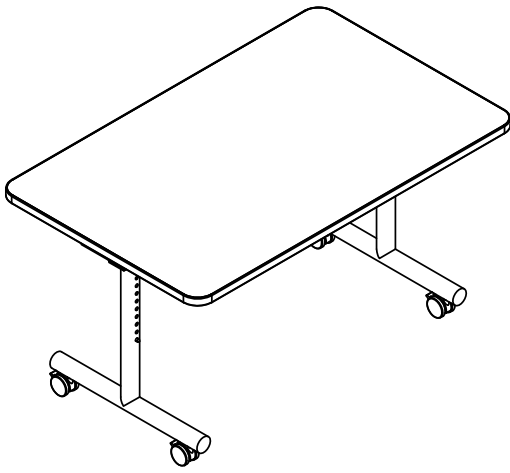

**Note:** 48"W tables are not wide enough for two people in most situations. Spectrum recommends at least a 60"W table to accommodate two people.

60"W Flex Flip Table

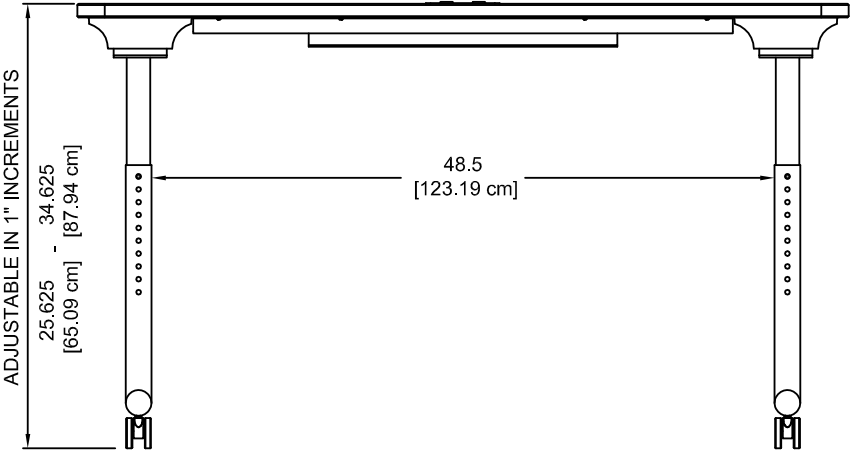
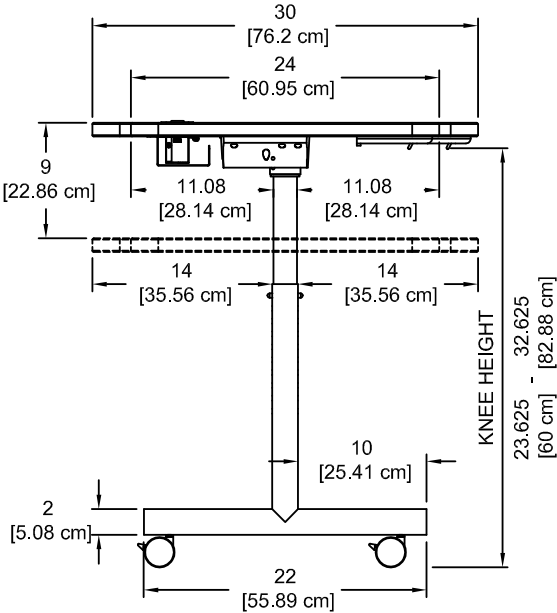
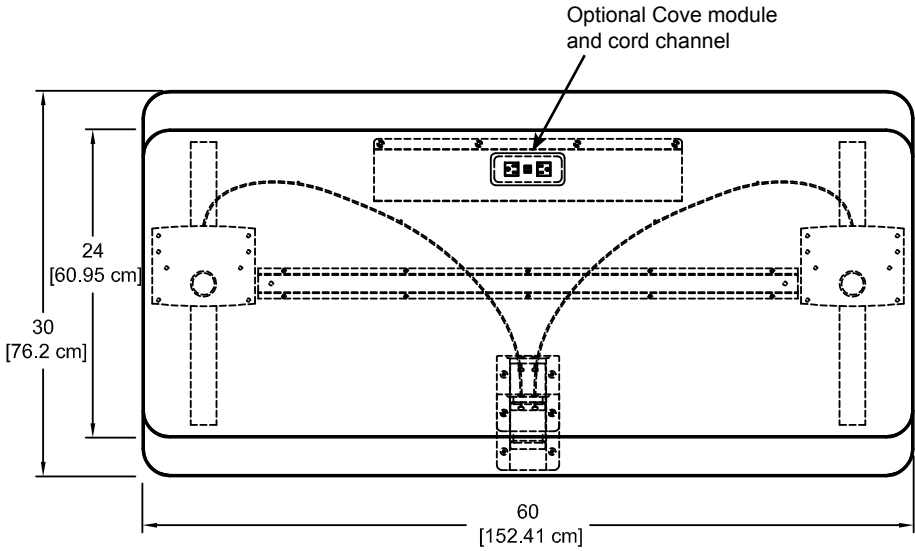
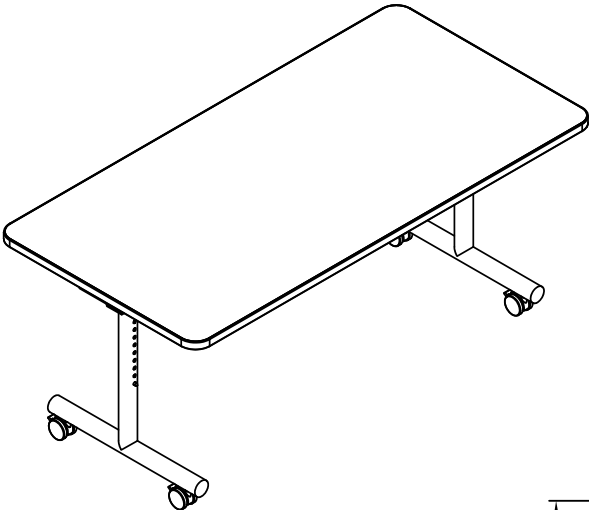



72"W Flex Flip Table

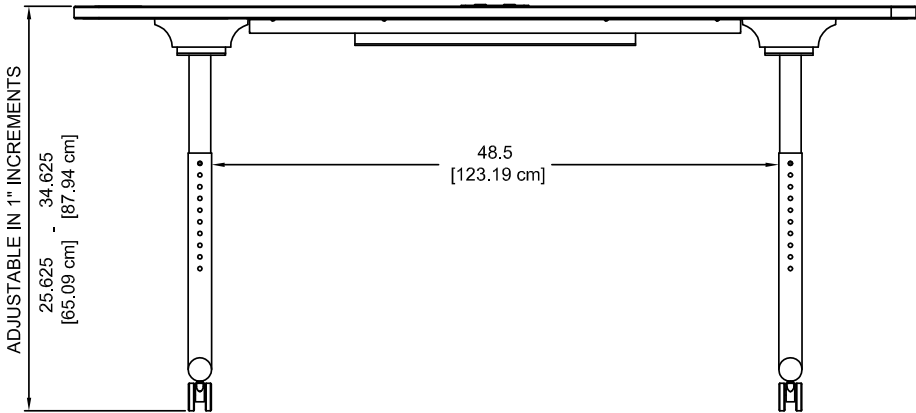
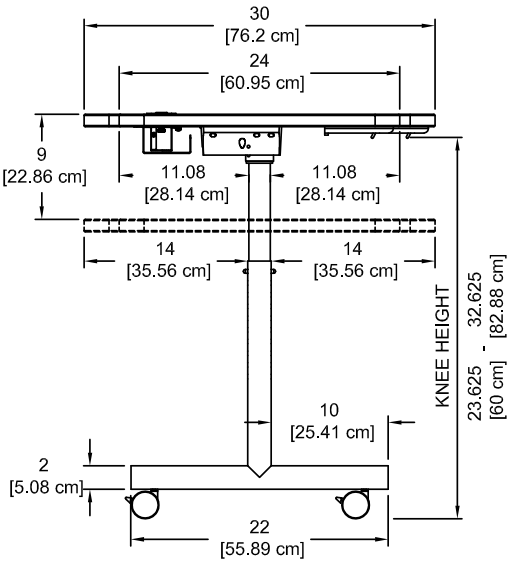
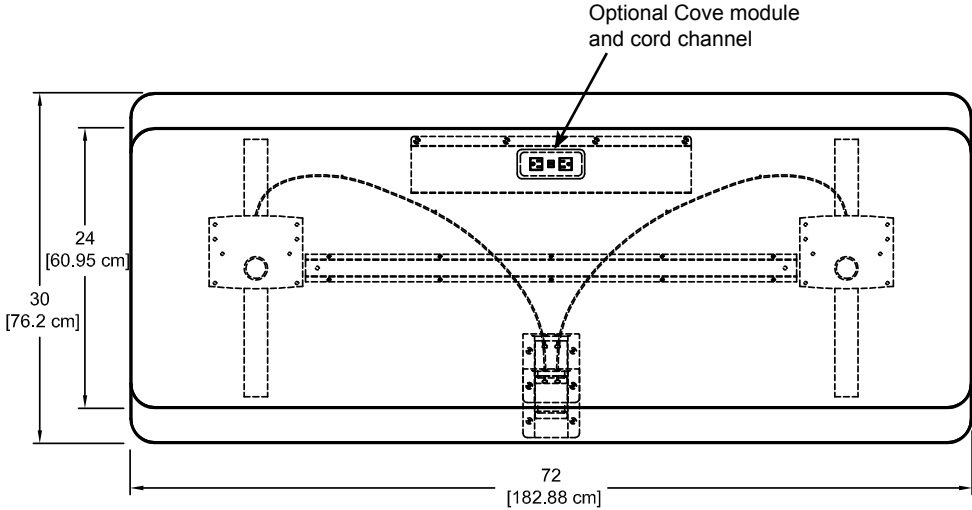
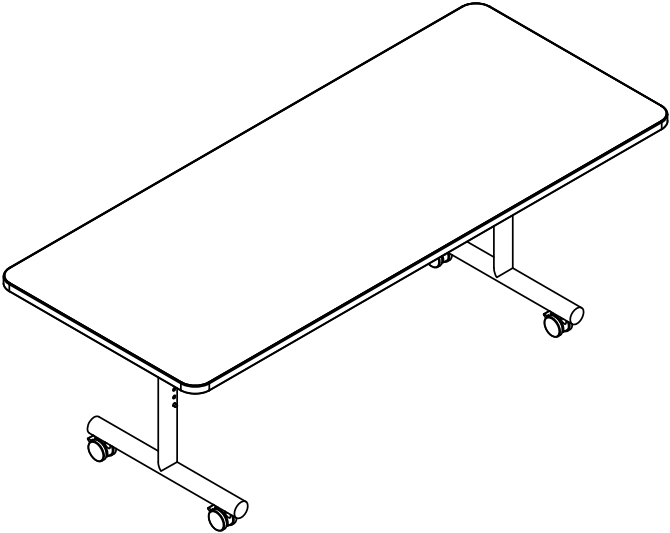

## Accessories *(Customer-installed when purchased separately.)*

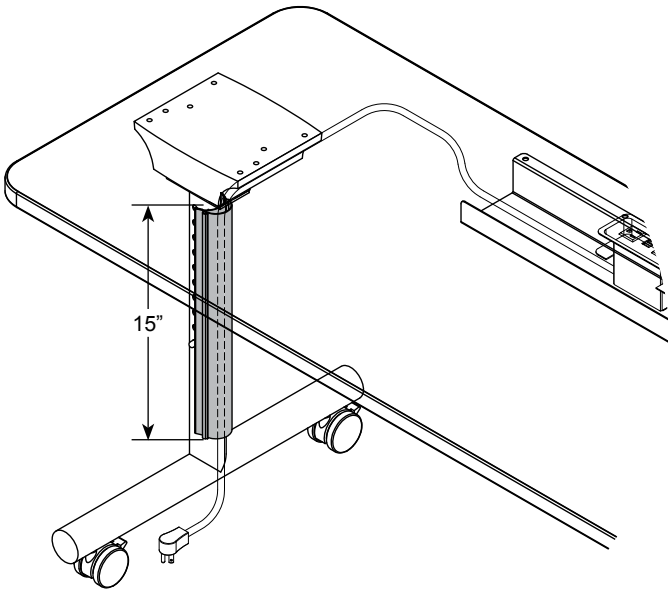

### **Leg Channel - 37318**

- Provides ability to route wires and cables from the floor to the worksurface (Use with Cove or other power modules-not included)
- High-impact polystyrene
- Color-black or silver
- Installs with double-sided tape
- Internal size (nominal):  
1.75"W [4.44 cm] .5"D [1.27 cm] x 15"H [30.5 cm]
- Shipping weight (nominal): 1 lb [.454 kg]



Easy Power Connection Kit with Cove™ Power Module

99047 - 48"W Easy Power Connection Kit  
 99048 - 60"W Easy Power Connection Kit  
 99049 - 72"W Easy Power Connection Kit  
 99050 - Starter Kit (One per row required)

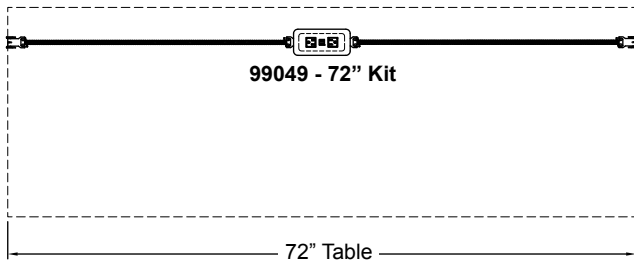
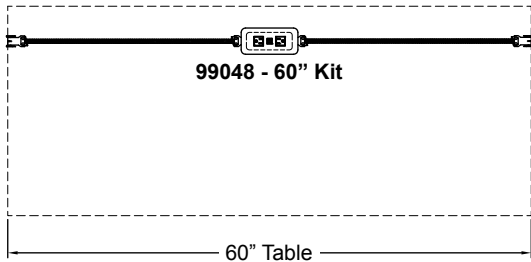
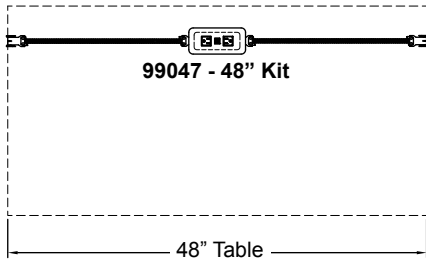
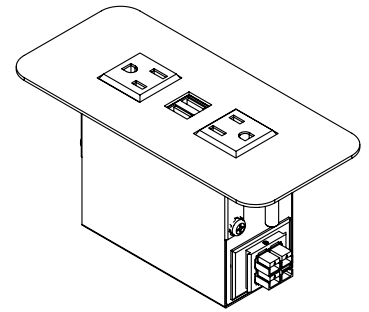

- Each table accommodates one power connection kit
- Two AC power receptacles
- Two USB charge ports (not data-compatible)
- Requires 5.25"W x 2"D worksurface cutout
- Flexible metal conduit is secured to worksurface underside
- Cove is ETL listed
- Thumbscrew clamps
- Cove available in Black or Silver
- Starter connects to standard 3-prong wall outlet

Cutout required:	5.25"W [13.3 cm] x 2"D [5.1 cm]
Power cord:	15A
Power receptacles:	12A, 120 VAC spill-resistant (2 receptacles)
USB charging ports:	2.1A (10.5W) (2 USB charging ports)
Cove dimensions:	6"W [15.2 cm] x 2.5"D [6.35 cm] x 3.18"H [8.1 cm]
Shipping weights:	99047 - 3.5 lb [1.59 kg] 99048 - 4 lb [1.82 kg] 99049 - 4.5 lb [2.04 kg] 99050 - 2.5 lb [1.14 kg]

- Each table accommodates one power connection kit
- Each row also requires one 99050 starter
- Typical installations do not exceed 6 or 7 Easy Power Connection Kits (or tables) per row (or circuit).

Cove Module available in Black or Silver



Worksurface cutout required

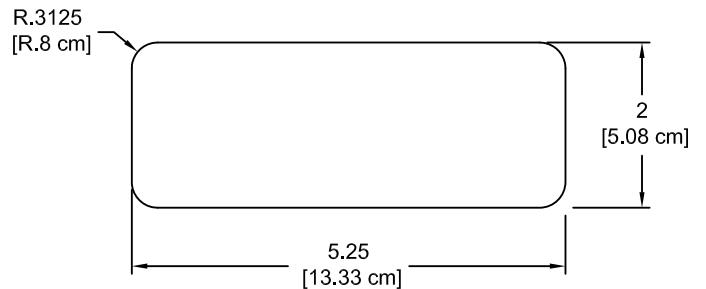

99050 - Starter Kit

(One per row required)  
 includes 20-15A adapter cord

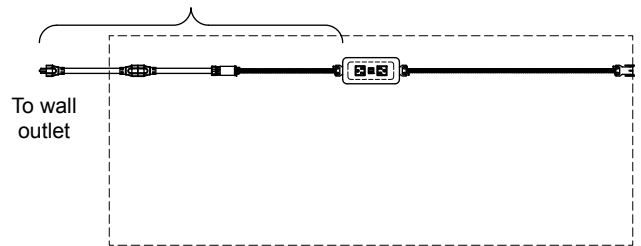

See [spectrumfurniture.com](http://spectrumfurniture.com) for the latest accessories and detailed warranty information.

# Warranty

## **WE WILL MAKE IT RIGHT FOR YOU!**

Spectrum is committed to provide complete customer satisfaction. Each of our products is manufactured from the best materials available and each product is stringently monitored throughout the production process through our P.A.C.E. program (Product Assurance to meet Customer Expectations).

We expressly warrant that Spectrum products will be of good quality and workmanship and free from defect for the period set out in the warranty table below from the date of delivery. This warranty shall not apply to defects or damage resulting from misuse, abuse, neglect, improper care, modification or repair not authorized by Spectrum, or any other cause outside the control of Spectrum. Spectrum will, at its sole option, either repair or replace the defective product.

This warranty is exclusive; no other warranty, written or oral, is expressed or implied. This warranty is given by Spectrum to Buyer and to no other person or legal entity. No Spectrum dealer, distributor, agent or employee is authorized to make any modification or addition to this warranty.

**NOTWITHSTANDING ANYTHING TO THE CONTRARY, SPECTRUM WILL NOT UNDER ANY CIRCUMSTANCES BE LIABLE FOR INDIRECT OR LIQUIDATED DAMAGES, INCLUDING CONSEQUENTIAL, INCIDENTAL AND SPECIAL DAMAGES. IN NO EVENT SHALL SPECTRUM'S LIABILITY, WHETHER UNDER CONTRACT OR WARRANTY, IN TORT OR OTHERWISE, EXCEED THE PURCHASE PRICE RECEIVED BY SPECTRUM FOR THE PRODUCT AT ISSUE AND "RECALL ACTION" EXPENSES. SPECTRUM SHALL NOT BE SUBJECT TO ANY OTHER OBLIGATIONS OR LIABILITIES, WHETHER ARISING OUT OF BREACH OF CONTRACT, WARRANTY, TORT (INCLUDING NEGLIGENCE AND STRICT LIABILITY) OR OTHER THEORIES OF LAW, WITH RESPECT TO PRODUCTS SOLD OR SERVICES RENDERED BY SPECTRUM, OR ANY UNDERTAKINGS, ACTS OR OMISSIONS RELATING THERETO.**

Our Customer Service Department is ready to provide immediate attention to any questions, comments or concerns. They are available to answer your calls Monday through Friday from 7 am to 5 pm CST. In addition your product comments or concerns are welcome via e-mail at: [spectrum@spectrumfurniture.com](mailto:spectrum@spectrumfurniture.com).

**Warranty Table**

<b>Item</b>	<b>Warranty Period</b> effective 1/1/2015
Adjustable Crank / Electric Desk Legs	• 1 Year
Flat Panel Desk Gas Cylinders	
Chairs <ul style="list-style-type: none"> <li>• Adjustable Height Chair Parts – including frames, gas cylinders, wood and plastic parts, control handles, casters</li> <li>• Adjustable Height Chair Upholstery</li> <li>• In-Stock Upholstery</li> <li>• Graded-In Fabrics and Customer Owned Material</li> </ul>	<ul style="list-style-type: none"> <li>• 7 Years</li> <li>• 2 Years</li> <li>• 2 Years</li> <li>• No Warranty</li> </ul>
Height Adjustable Columns and Lifts	• 1 Year
General Use Casters	
Electrical (including timers and LINAK actuators)	• 2 Years
Keyboard / Mouse Trays	• 1 Year
Flat Panel Monitor Arms <ul style="list-style-type: none"> <li>• Flat Panel Monitor Arm – General Parts</li> <li>• Flat Panel Monitor Arm – Gas Cylinders</li> </ul>	<ul style="list-style-type: none"> <li>• 5 Years</li> <li>• 2 Years</li> </ul>
Desks and Lecterns <ul style="list-style-type: none"> <li>• Computer Desk Chassis</li> <li>• Cart Chassis</li> <li>• Lectern Chassis</li> </ul>	• 10 Years

