

Assembly Instructions

⚠ Important ⚠

Before you begin, read and comply with all safety and operating instructions, and ensure all parts and correct quantities are included.

Any parts damaged during shipment must be reported within 5 days of receipt. To report information regarding missing parts or damage, to purchase parts or accessories, or if you have any questions, please contact us.

www.spectrumfurniture.com
 800-235-1262, 715-723-6750

Thank you for purchasing Spectrum products!

(1) Modesty panel

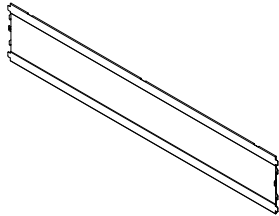

Panel only:	with insert panel:
0190447 - 48"W	0190450 - 48"W
0190448 - 60"W	0190451 - 60"W
0190449 - 72"W	0190452 - 72"W



(1) 0133632
Right Corner



(1) 0133629
Left Corner



(11) 026073
#8 x 3/4" PHSM



(3) 0134099
Mounting bracket

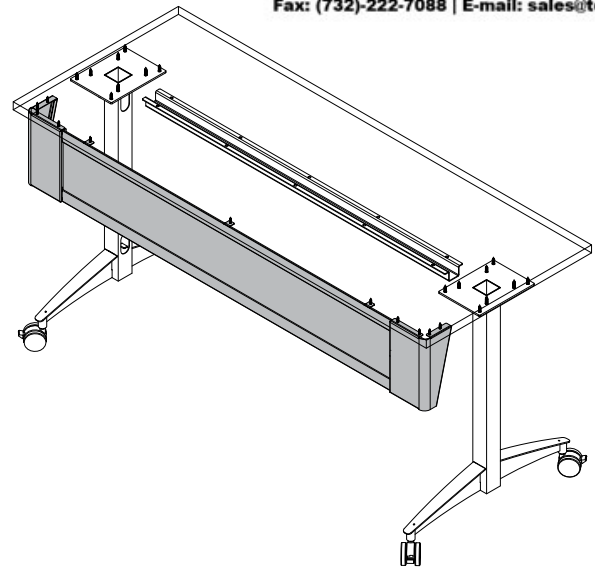

Modesty Panel for Flex Active Table

37234 - 48"W Table
 37235 - 60"W Table
 37236 - 72"W Table

Installation

Note: Before installing, flip the table face down (laminite side-down) onto a flat, non-abrasive surface like another table.

Tools Required



Phillips
screwdriver

1. Orient the modesty panel and corners as shown and lock together.
Figure 1.

2. Place a mounting bracket inside each panel opening.
Figure 2.

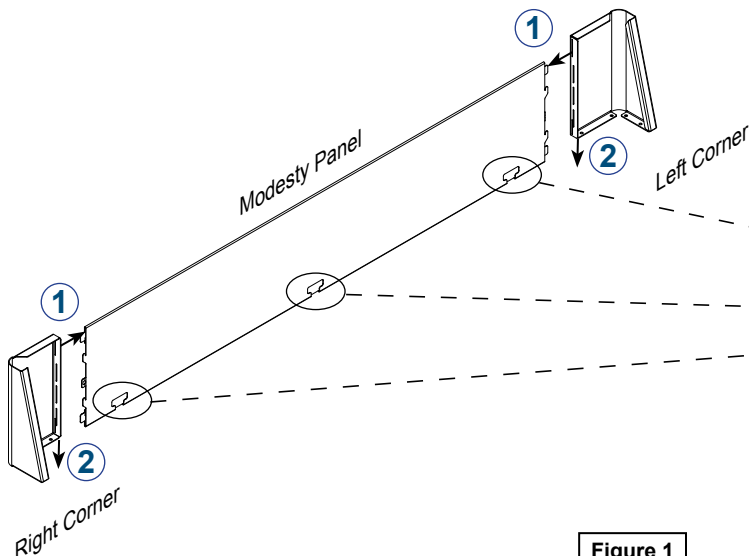

Figure 1

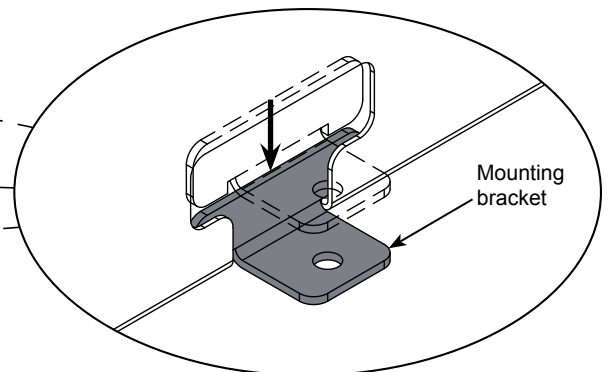

Figure 2

3. Align the modesty panel, bracket, and worksurface mounting holes.
Figure 3.

4. Attach to worksurface with (11) #8 x 3/4" PHSM screws.
Figure 4.

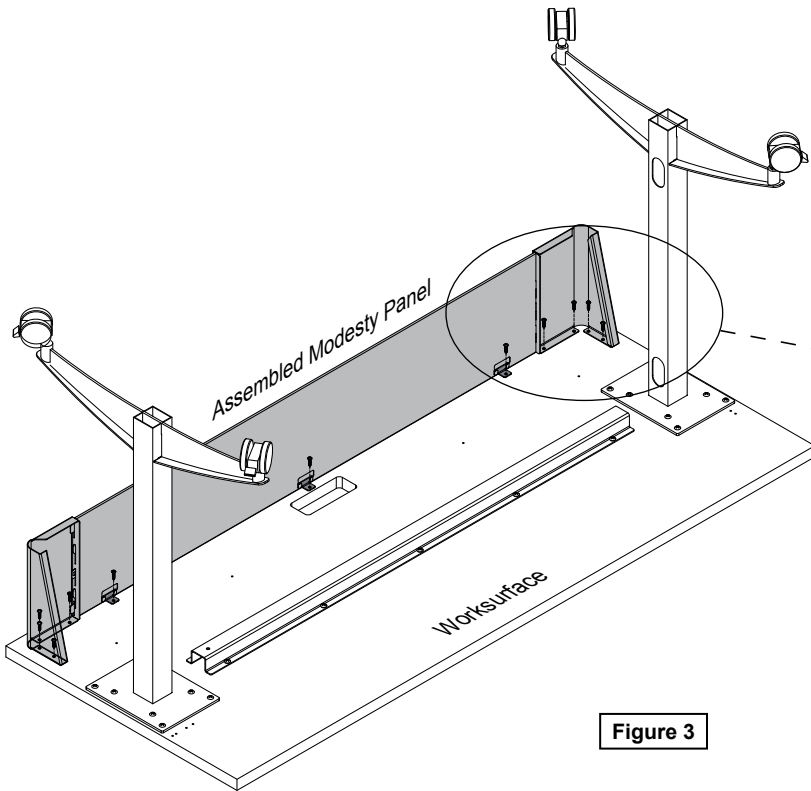

Figure 3

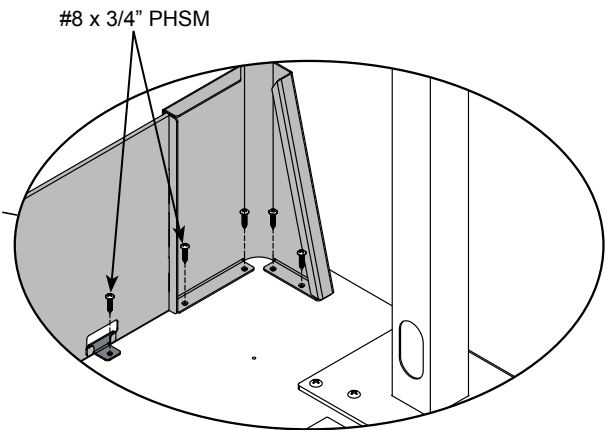

Figure 4