

Technical Specifications

55106

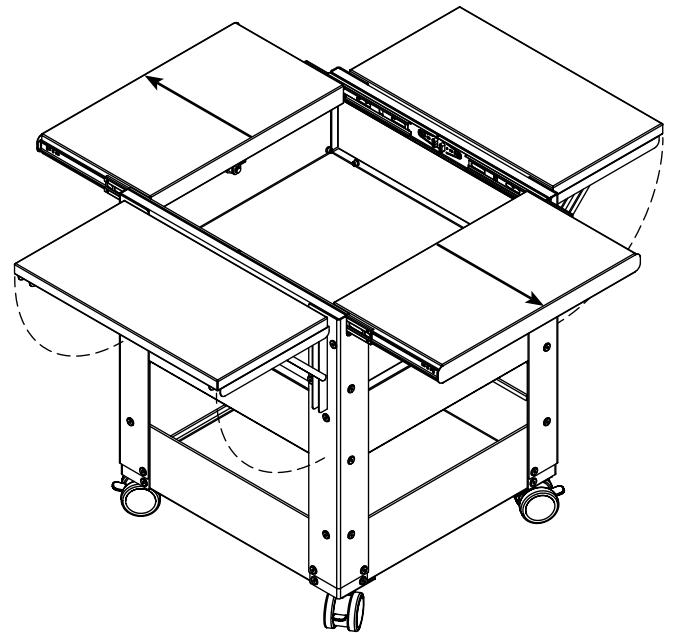
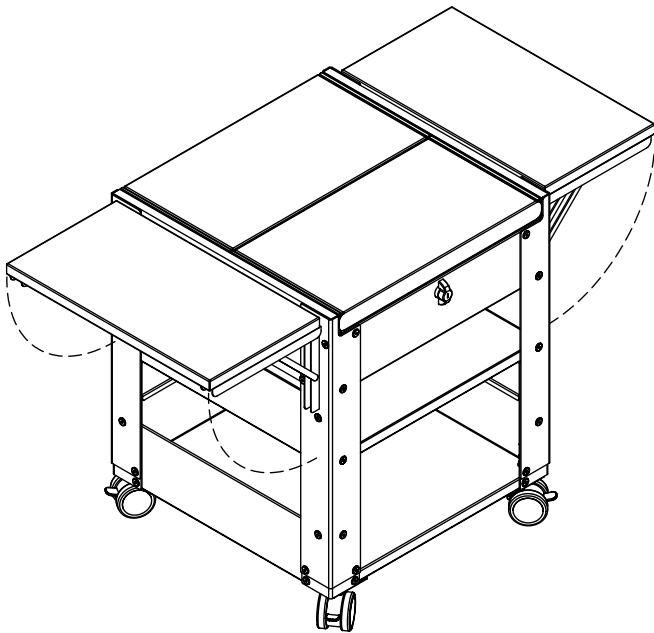

The Builder Cart™ supports makerspace environments with storage and workspace all in one! Designed for the latest manipulatives, including Lego®, magnetic letters, K'Nex®, Magna-Tile® systems, and more.

Features and Benefits

- Durable powder coated steel chassis provides a long-lasting finish
- Steel construction provides durability and magnetic-friendly surfaces
- Small cart footprint (28"W x 24"D) saves valuable classroom space
- 30-36" fixed-height adjustability in 2" increments (*user-adjustable*) (*factory-assembled setting: 30"H*)
- 2 locking slide-out shelves, and 2 flip-up shelves provide workspace for up to 4 students
- 2 lower storage shelves for supplies or additional bins
- Four inboard 3" twin-wheel casters (*4 locking*) provide easy rolling / transport (*rated at 165 lb each*)
- Optional tote bins available in different sizes, provide storage
- Optional lid kit prevents tote bin spills
- SCS Indoor Advantage Gold Certified, Meets or exceeds applicable ANSI-BIFMA test standards
- Ships fully-assembled
- Warranted to be free of all defects in materials and workmanship for 10 years
- Designed and assembled in Chippewa Falls, WI, USA

Color Options

Light Blue



White

Construction

- Metal components consist of 16-gauge steel
- All metal components are finished with a scratch-resistant powder coat epoxy
- Side panels constructed from 3/4" thick NAF (No Added Formaldehyde) composite board with .030" high-pressure laminate on one face, and a balancing phenolic backer on the opposing face
- Each Builder Cart ships factory-assembled

Specifications

Nominal dimensions	28"W x 24"D x 30-36"H	
Fixed worksurface heights available <i>(user-adjustable with 4mm hex wrench)</i>	<ul style="list-style-type: none"> • 36"H [91.44 cm] • 34"H [86.36 cm] • 32"H [81.28 cm] • 30"H [76.2 cm] <i>(factory-assembled height)</i> 	
Upper compartment	Internal dims: 22"W [55.88 cm] 21"D [53.34 cm] x 5.6875"H [14.45 cm] Weight capacity: 25 lb [11.4 kg]	
Mid Shelf	23"W [58.4 cm] x 23"D [58.4 cm] x 6.75"H Weight capacity: 25 lb [11.4 kg]	
Lower Shelf	23"W [58.4 cm] x 23"D [58.4 cm] x	<ul style="list-style-type: none"> • 18"H [45.72 cm] • 16"H [40.64 cm] • 14"H [35.56 cm] • 12"H [30.48 cm]
	Weight capacity: 25 lb [11.4 kg]	
Pull-out tray	21.125"W x 11.875"D x 1"H Weight capacity: 25 lb [11.4 kg]	
Flip-up shelf	22.125"W x 12"D x 1"H Weight capacity: 25 lb [11.4 kg]	
3" Twin Wheel casters	Twin wheel with brake Weight capacity: 165 lb [74.9 kg] each	
Unit weight (nominal)	100 lb [45.4 kg]	
Shipping weight (nominal)	132 lb [59.9 kg]	

Specifications subject to change without notice

Optional Tote bins / lids
(order separately)



3" Twin-Wheel caster

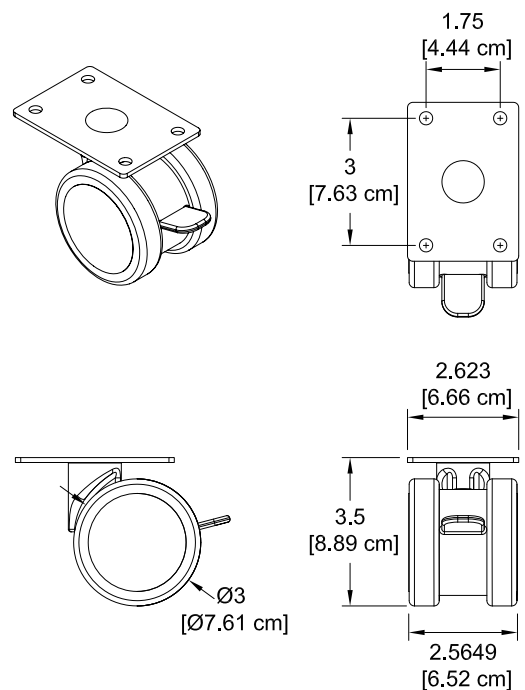

Builder Cart
 (shown with trays and flip-up
 shelves retracted)

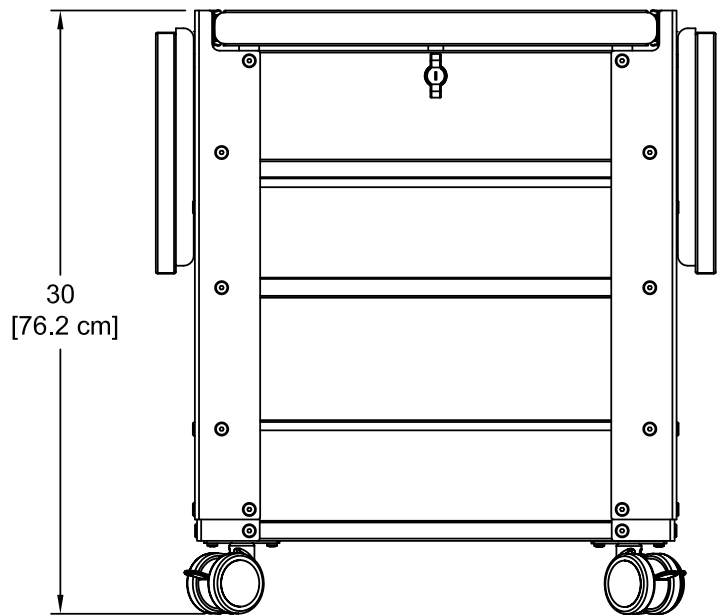
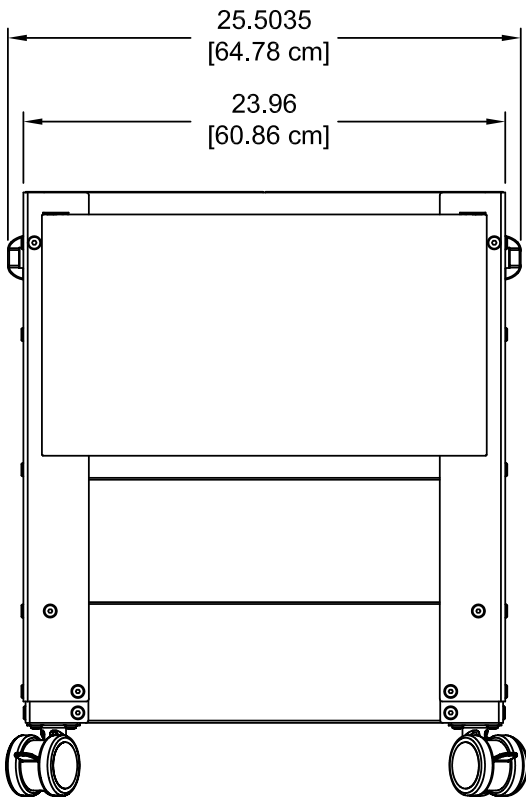
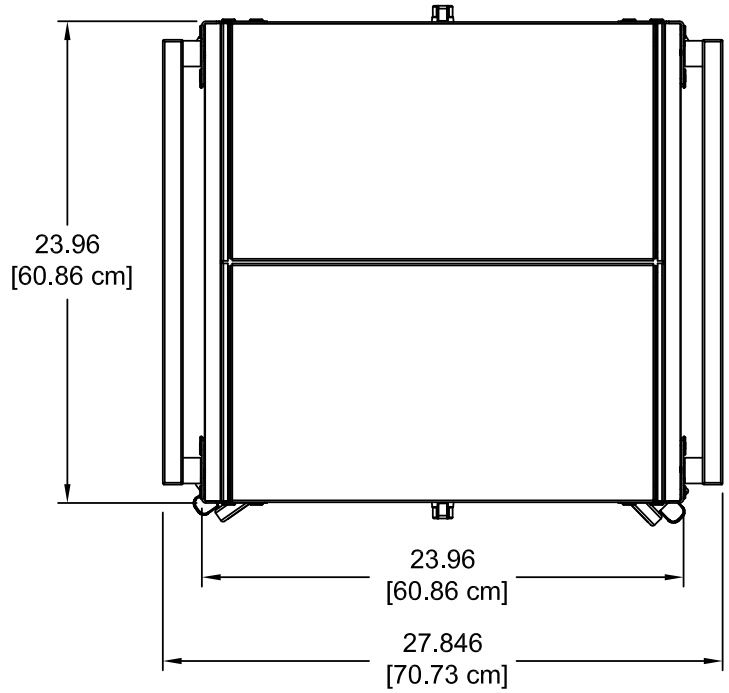
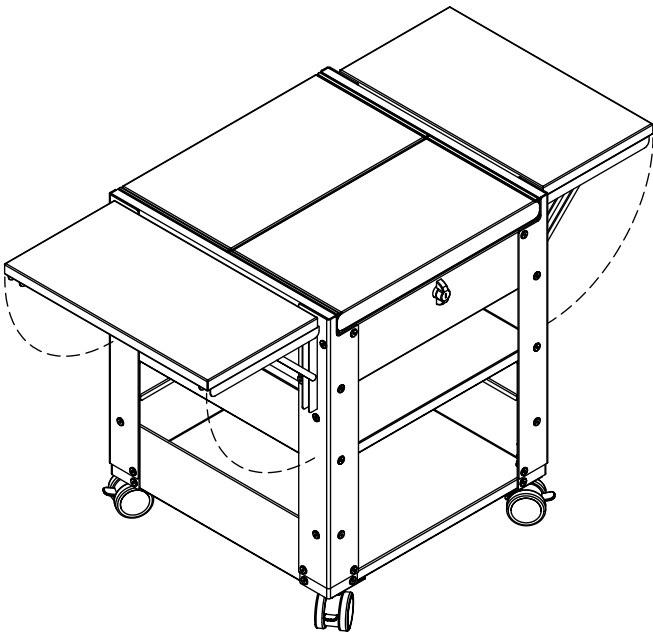

Builder Cart
 (shown with trays and flip-up shelves extended)

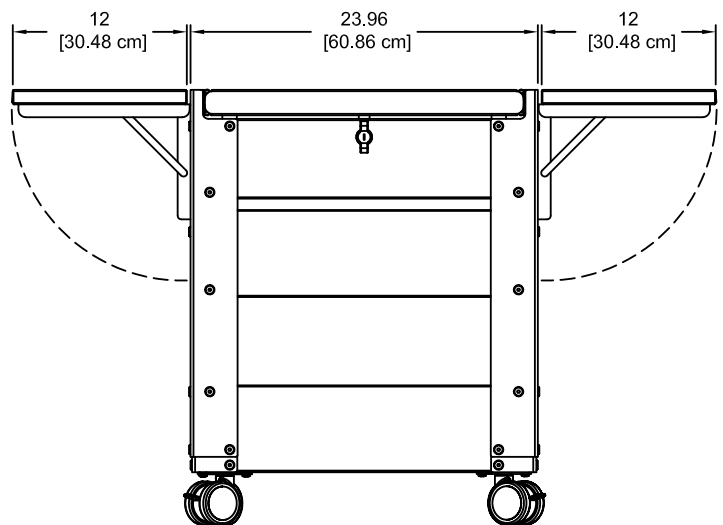
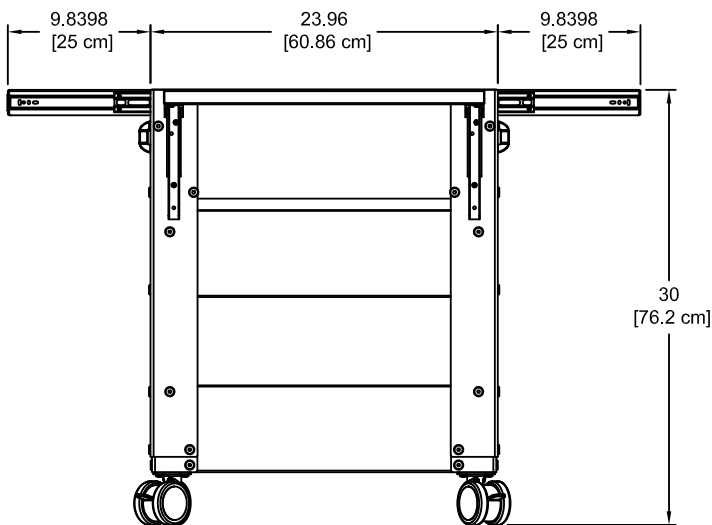
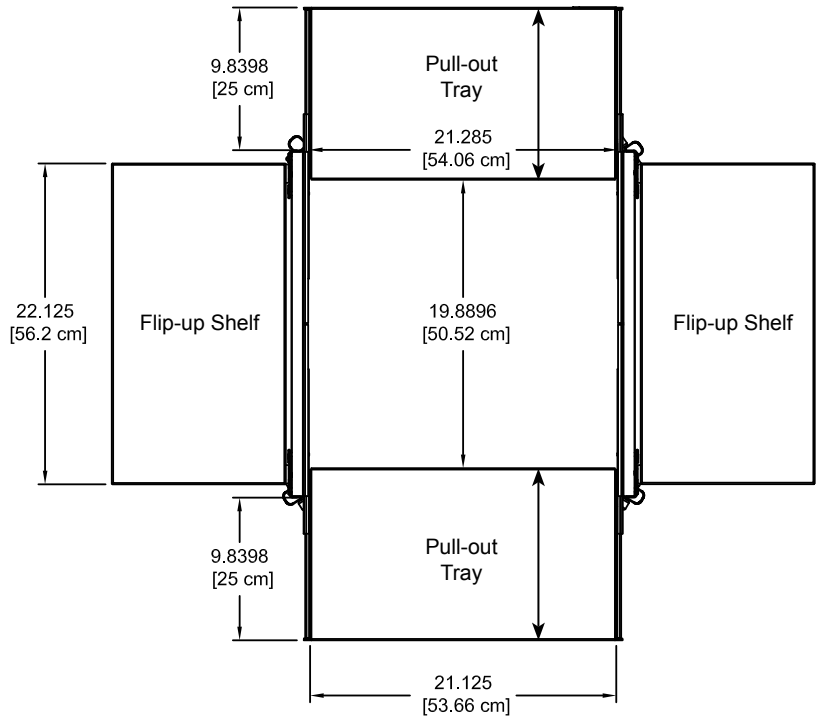
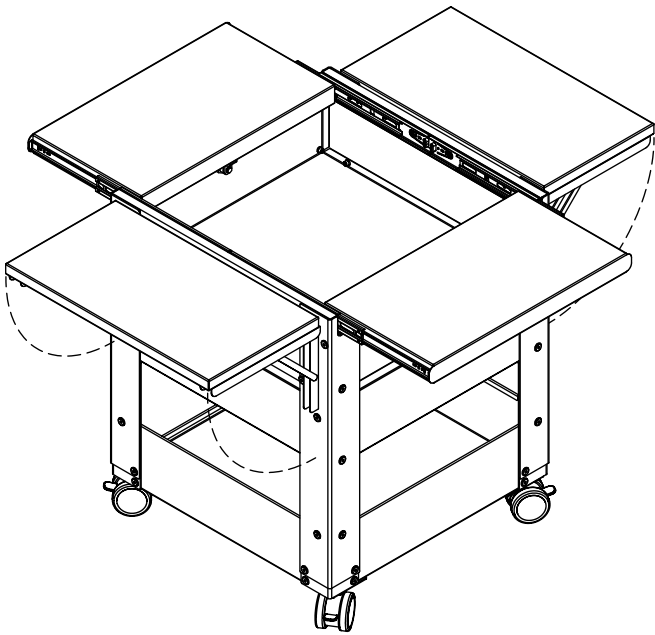

Adjustable height
(user-adjustable with 4mm hex wrench)

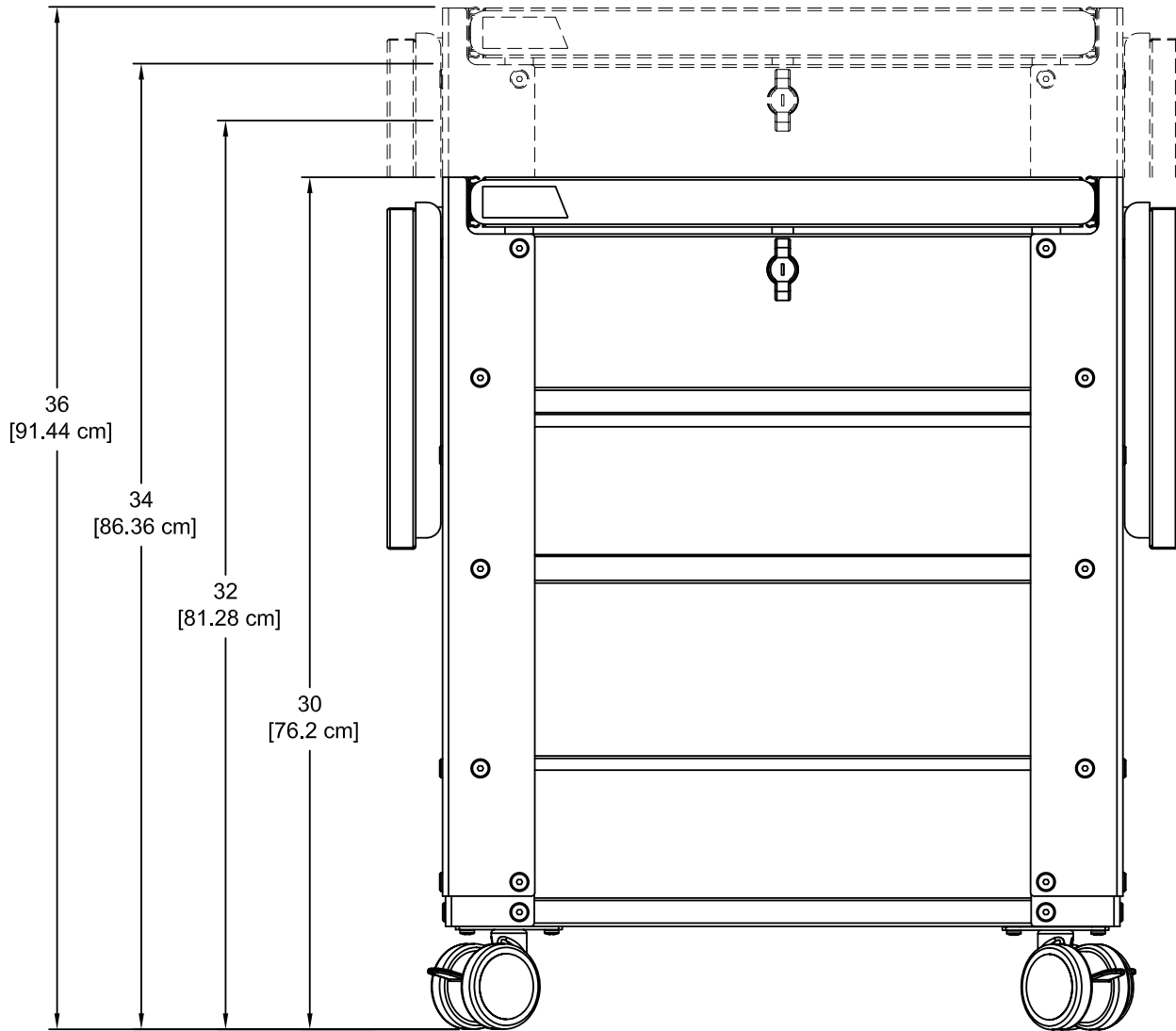

Accessories



Tote Bins - 5-pack - 95005

- 12.2"W x 7.8"D x 5.1"H (6 qt)
- Drop-resistant plastic
- Includes 5 bins in same color (choose from green, blue, yellow, red, or translucent)
- Unit weight (ea): .5 lb [.227 kg]
- Shipping weight: 4 lb [1.8 kg]



Tote Bins - 4-pack (4-color) - 95008

- 12.2"W x 7.8"D x 5.1"H (6 qt)
- Drop-resistant plastic
- Includes (1) green, (1) blue, (1) yellow, (1) red
- Unit weight (ea): .5 lb [.227 kg]
- Shipping weight: 3.5 lb [1.59 kg]



Lid Kit for Tote Bins

5-pack - 95007

4-Pack - 95009

- 12.2"W x 7.8"D
- Translucent
- Drop-resistant plastic
- Unit weight (ea): .25 lb [.11 kg]
- Shipping weight: 2 lb [.908 kg]

Warranty

We will make it right for you!

Spectrum is committed to provide complete customer satisfaction. Each of our products is manufactured from the best materials available and each product is stringently monitored throughout the production process through our P.A.C.E. program (Product Assurance to meet Customer Expectations).

We expressly warrant that Spectrum products will be of good quality and workmanship and free from defect for the period set out in the warranty table below from the date of delivery. This warranty shall not apply to defects or damage resulting from misuse, abuse, neglect, improper care, modification or repair not authorized by Spectrum, or any other cause outside the control of Spectrum. Spectrum will, at its sole option, either repair or replace the defective product.

This warranty is exclusive; no other warranty, written or oral, is expressed or implied. This warranty is given by Spectrum to Buyer and to no other person or legal entity. No Spectrum dealer, distributor, agent or employee is authorized to make any modification or addition to this warranty.

NOTWITHSTANDING ANYTHING TO THE CONTRARY, SPECTRUM WILL NOT UNDER ANY CIRCUMSTANCES BE LIABLE FOR INDIRECT OR LIQUIDATED DAMAGES, INCLUDING CONSEQUENTIAL, INCIDENTAL AND SPECIAL DAMAGES. IN NO EVENT SHALL SPECTRUM'S LIABILITY, WHETHER UNDER CONTRACT OR WARRANTY, IN TORT OR OTHERWISE, EXCEED THE PURCHASE PRICE RECEIVED BY SPECTRUM FOR THE PRODUCT AT ISSUE AND "RECALL ACTION" EXPENSES. SPECTRUM SHALL NOT BE SUBJECT TO ANY OTHER OBLIGATIONS OR LIABILITIES, WHETHER ARISING OUT OF BREACH OF CONTRACT, WARRANTY, TORT (INCLUDING NEGLIGENCE AND STRICT LIABILITY) OR OTHER THEORIES OF LAW, WITH RESPECT TO PRODUCTS SOLD OR SERVICES RENDERED BY SPECTRUM, OR ANY UNDERTAKINGS, ACTS OR OMISSIONS RELATING THERETO.

Our Customer Service Department is ready to provide immediate attention to any questions, comments or concerns. They are available to answer your calls Monday through Friday from 7 am to 5 pm CST. In addition your product comments or concerns are welcome via e-mail at: spectrum@spectrumfurniture.com.

Warranty Table

Item	Warranty Period
Adjustable Crank / Electric Desk Legs	• 1 Year
Flat Panel Desk Gas Cylinders	
Chairs <ul style="list-style-type: none"> • Adjustable Height Chair Parts – including frames, gas cylinders, wood and plastic parts, control handles, casters • Adjustable Height Chair Upholstery • In-Stock Upholstery • Graded-In Fabrics and Customer Owned Material 	<ul style="list-style-type: none"> • 7 Years • 2 Years • 2 Years • No Warranty
Height Adjustable Columns and Lifts	• 1 Year
General Use Casters	
Electrical (including timers and LINAK actuators)	• 2 Years
Keyboard / Mouse Trays	• 1 Year
Flat Panel Monitor Arms <ul style="list-style-type: none"> • Flat Panel Monitor Arm – General Parts • Flat Panel Monitor Arm – Gas Cylinders 	• 10 Years
Desks and Lecterns <ul style="list-style-type: none"> • Computer Desk Chassis • Cart Chassis • Lectern Chassis 	• 10 Years

