

S3 Coding Module™

55527H0 - No power
55527HC - w/ USB power

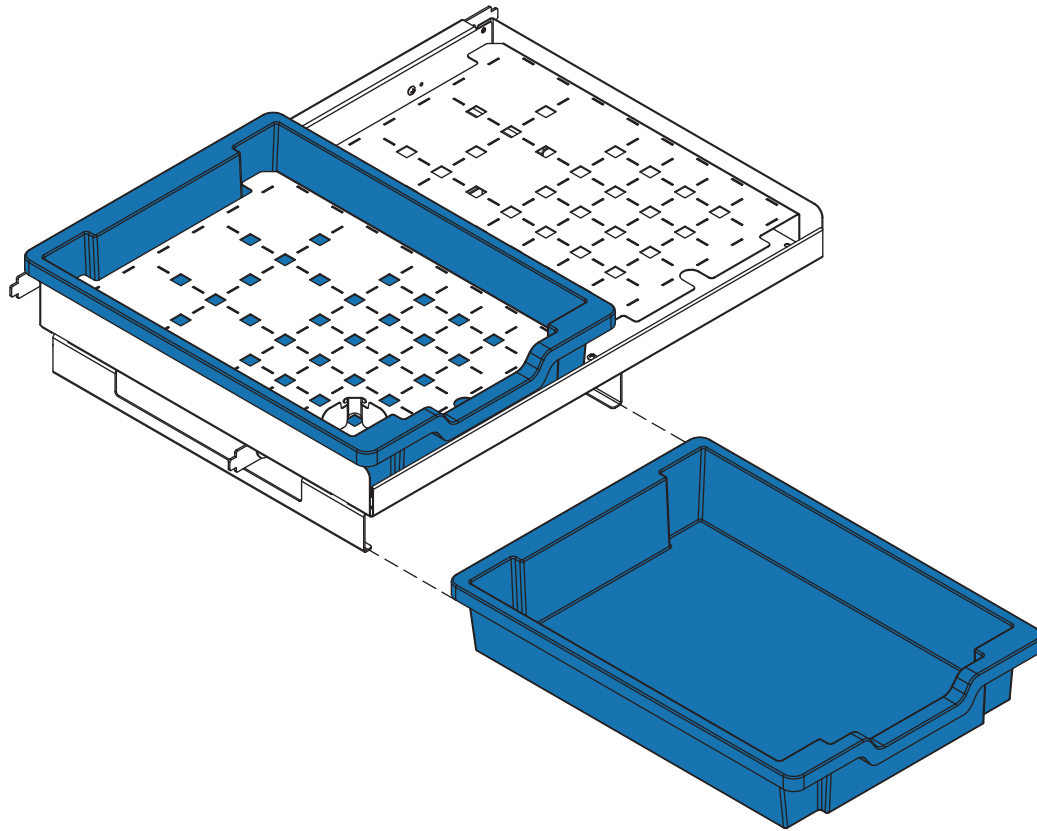

Important	Important	Importante
<p>Before using this product:</p> <ul style="list-style-type: none"> • Read this manual • Comply with all safety and operating instructions • Ensure all parts and correct quantities are included <p>Any parts damaged during shipment must be reported within 5 days of receipt. To report information regarding missing parts or damage, to purchase parts or accessories, or if you have any questions, please contact us.</p> <p>Thank you for purchasing Spectrum products!</p>	<p>Avant d'utiliser ce produit:</p> <ul style="list-style-type: none"> • Veuillez à lire ce guide • Respectez les consignes de sécurité et d'utilisation • Vérifiez que vous disposez de toutes les pièces nécessaires à l'installation <p>Les pièces endommagées pendant le transport doivent faire l'objet d'un rapport dans les 5 jours de leur réception. Veuillez prendre contact avec nous si des pièces manquent ou sont abîmées, si vous avez des questions, ou encore pour acheter des pièces ou des accessoires.</p> <p>Merci pour votre achat d'un produit Spectrum!</p>	<p>Antes de utilizar este producto:</p> <ul style="list-style-type: none"> • Lea este manual • Cumpla con todas las instrucciones de prevención de accidentes y operativas • Revise que todas las partes y las cantidades correctas estén incluidas <p>Si alguna parte se dañó durante el embarque, deberá reportarla en un lapso de 5 días a partir de la recepción. Para reportar cualquier información sobre partes faltantes o dañadas, para adquirirlas o comprar accesorios, o bien, si tiene alguna duda, póngase en contacto con nosotros.</p> <p>¡Gracias por adquirir productos Spectrum!</p>



<http://www.spectrumfurniture.com>

Owner's Manual Le manuel du propriétaire El manual del propietario	Specs Spécifications Especificaciones	Video Vidéo Vídeo
--	---	-------------------------



800-235-1262

Components

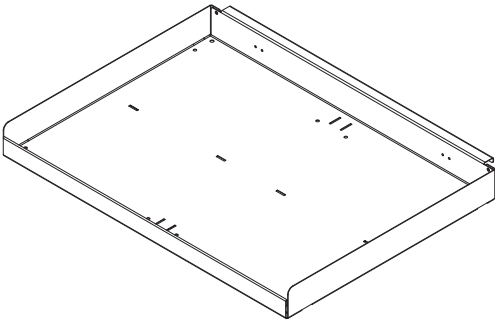

(1) 0147901
Tray

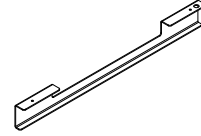

(2) 0147900
Slide bracket

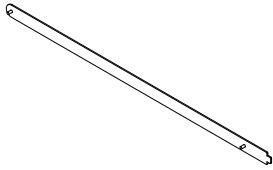

(2) 0142528
Bar support
(with threaded weld studs)

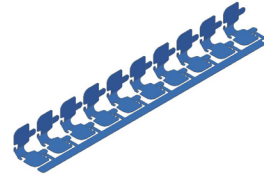

(2) 0147973
Divider tabs

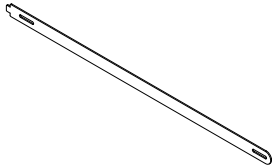

(2) 0145039
Bar support B-side
(with slots)

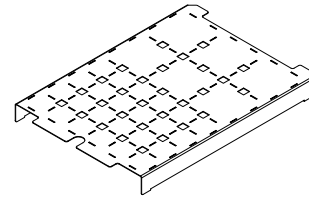

(2) 0147925
Universal panel



(4) 056284
8-32 Wing nut

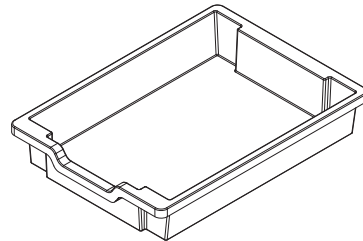

(2) 0191218
Shallow tray

Hardware



(4) 0190174
#8 x 3/8" PHSM

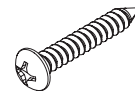

(2) 042749
#8 x 1" PHSM

55527HC w/ USB power includes:

(2) 0191496
6-Port USB chargers



(1) 0191567
Splitter



1 Assemble bar supports

1. The bars should be assembled with the tabs facing away from each other as shown in **Figure 1**.
2. Loosen the (2) wingnuts slightly.
3. Repeat for the 2nd set of bars.

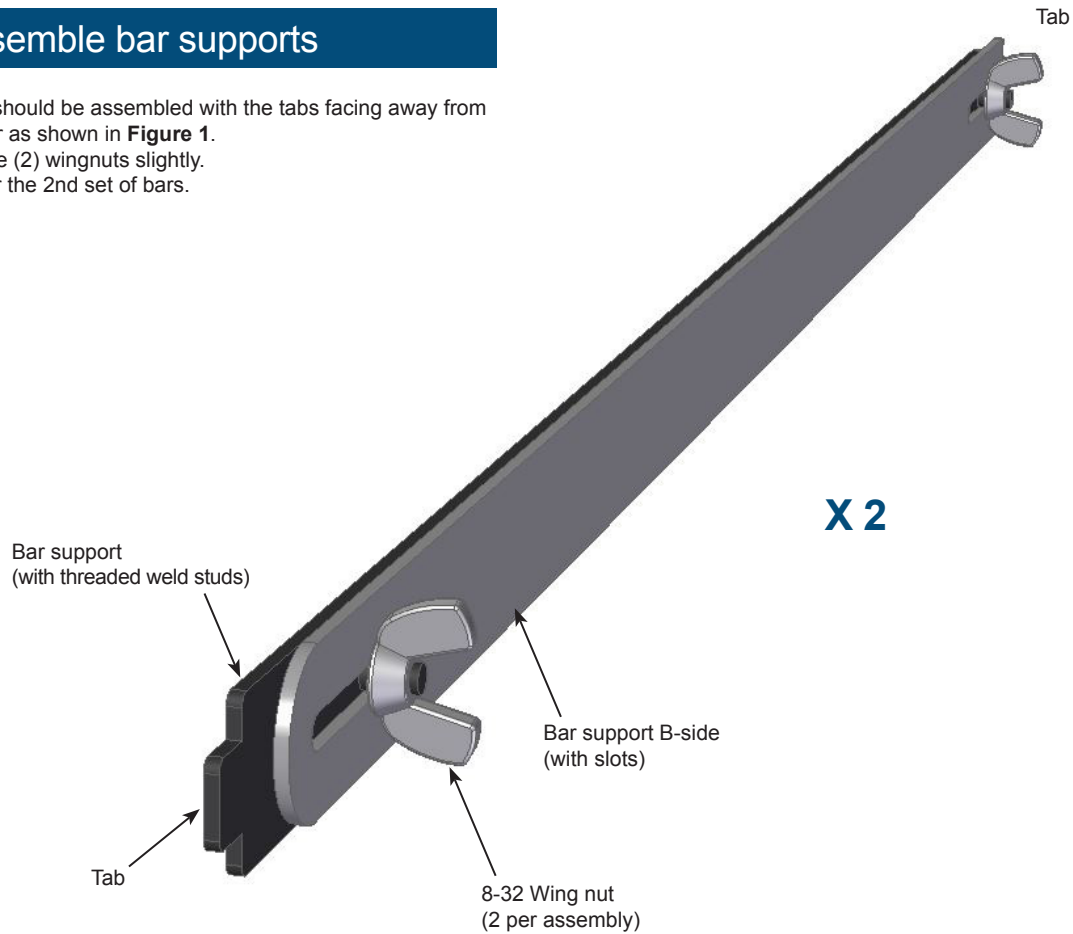

Figure 1

2 Install bars into cart

1. Determine the approximate location (height) you would like the module to be mounted. The rear bar is (1) slot higher than the front.
2. Insert one tab into a slot in the left slotted upright. **Figure 2**.
3. Insert the opposite tab into the corresponding right slotted upright and fully extend the bar assembly into place.
4. Lock the extended position of the bars by securely tightening the (2) wingnuts. Be sure both wingnuts are tight.
5. Repeat for the 2nd set of bars.

Note: When determining the location of the module, be sure the module will clear any obstructions that may be inside the cabinet and enough clearance (height) is provided for all module devices.

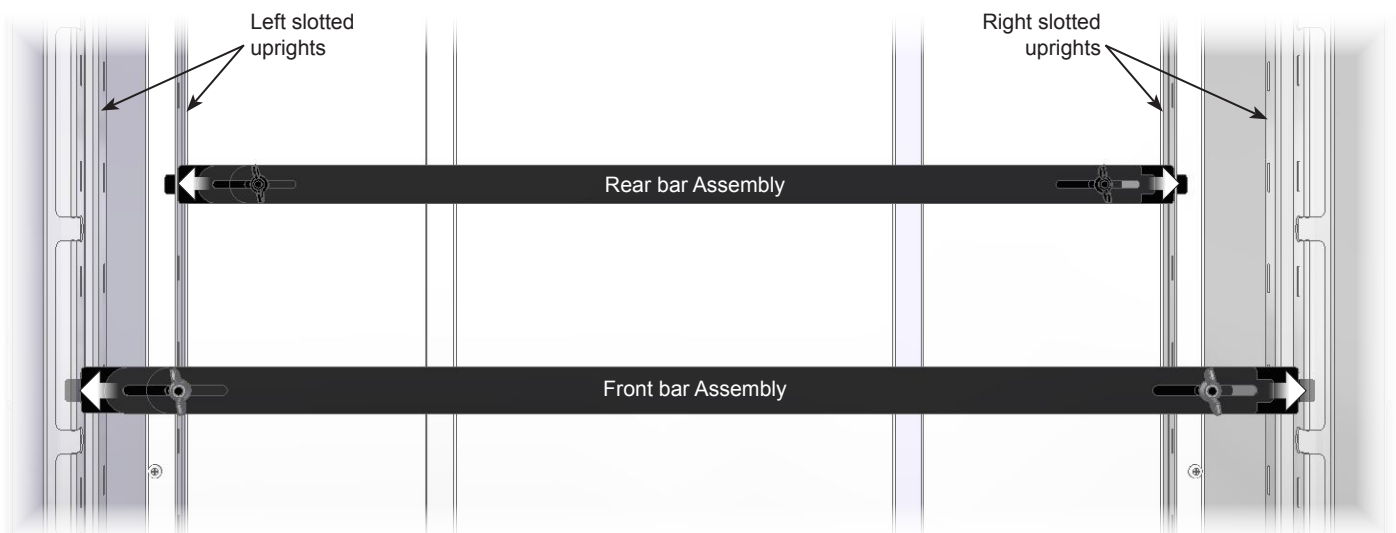

Figure 2

3 Attach slide brackets to tray

1. Attach each slide bracket to the bottom of the tray with (2) #8 x 3/8"PHSM screws. **Figure 3.**
2. Install (2) #8 x 1" PHSM screws into the back of the module-this will prevent the module from being removed.

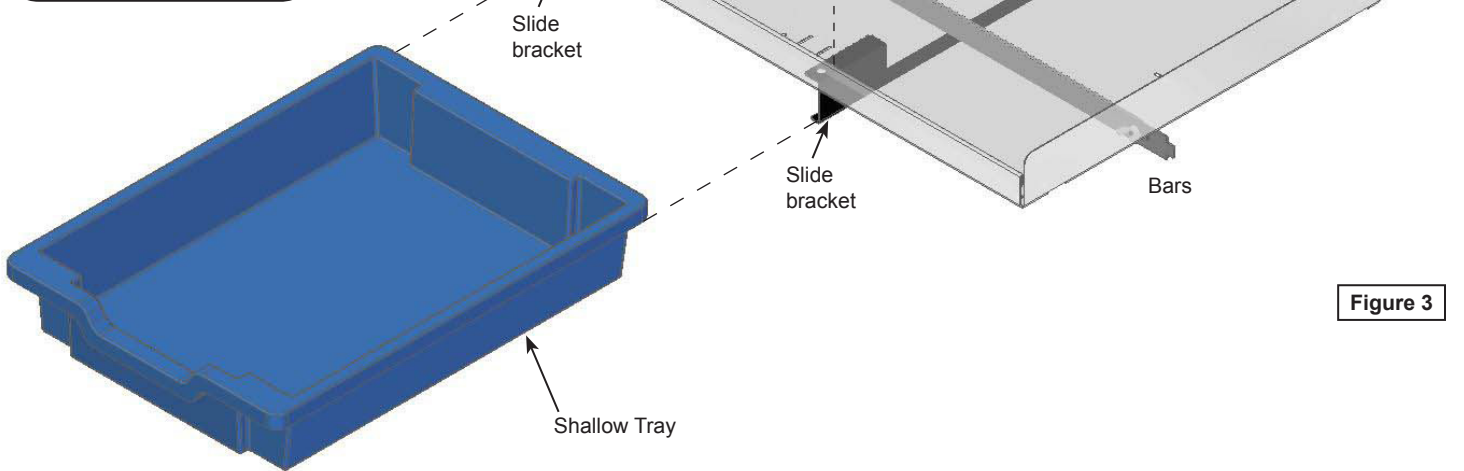
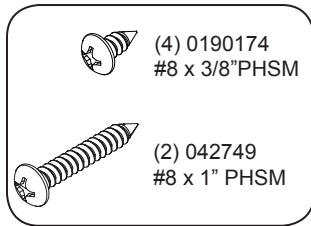

Figure 3

4 Install tray onto bars

1. Carefully set the empty tray onto both sets of bars. Be sure the rear channel "hooks" the rear set of bars fully. **Figure 4.1.**
2. Install (2) #8 x 1" PHSM screws into the back of the module-this will prevent removal. **Figure 4.2.**

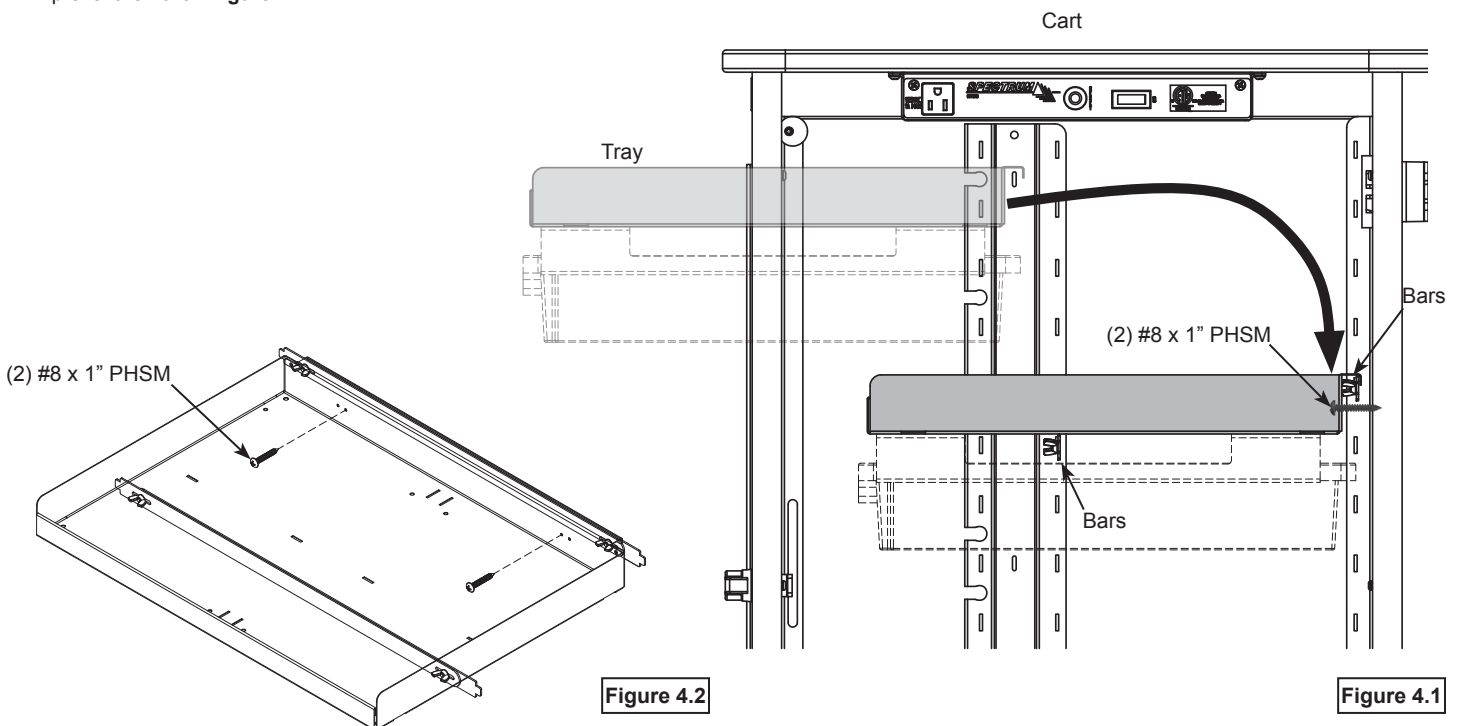
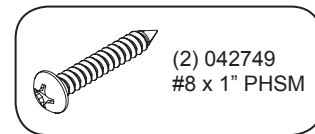

Figure 4.2

Figure 4.1

5 Dividers

1. Pull dividers off bar assembly. **Figure 5.1.**

Note: Dividers are designed for semi-permanent installation and use on the universal tray. Dividers can be repositioned by straightening the tabs, but excessive bending / re-bending cycles can cause the tabs to break.

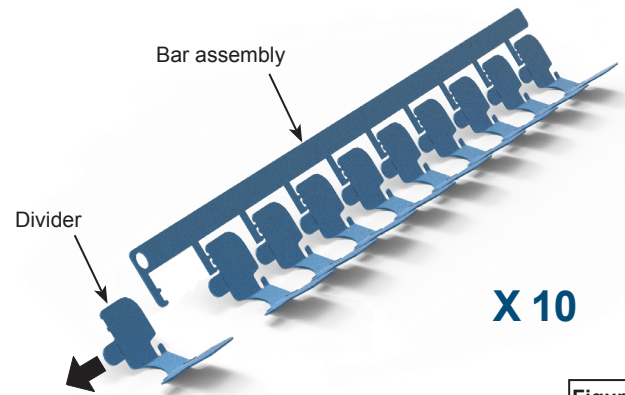

Figure 5.1

2. Place dividers into universal tray slots where needed. **Figure 5.2,**



Figure 5.2

3. See p.6 for spacing / location suggestions. **Figure 5.3.**

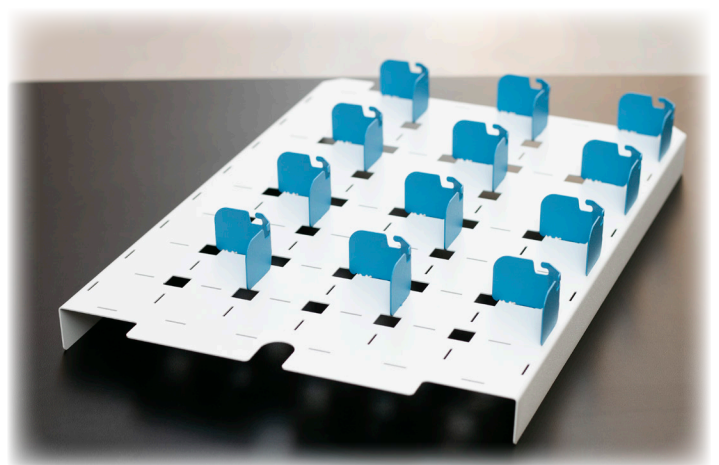

Figure 5.3

4. To lock each divider into place, bend both tabs 90-degrees. **Figure 5.4.**

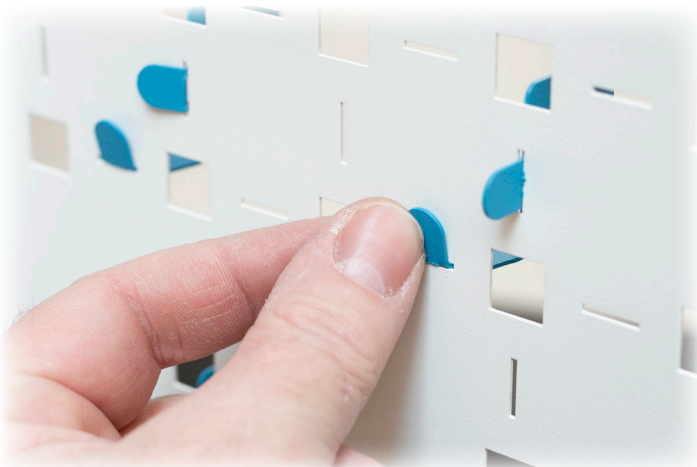

Figure 5.4

5. Route each charge cord through a tray hole and around the divider. Secure cord to divider using the slot. **Figure 5.5.**

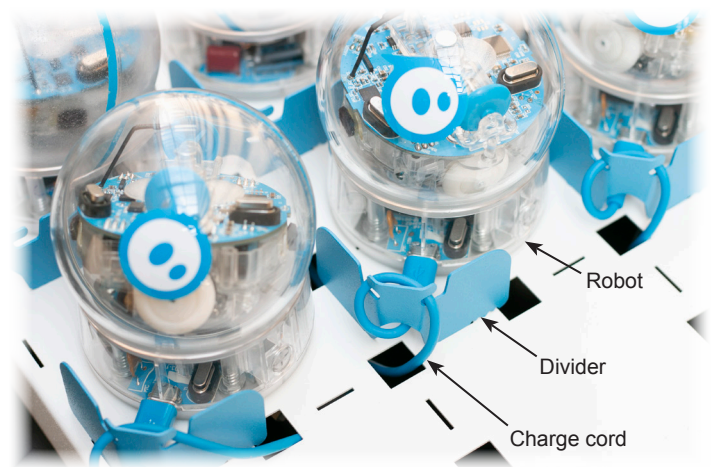
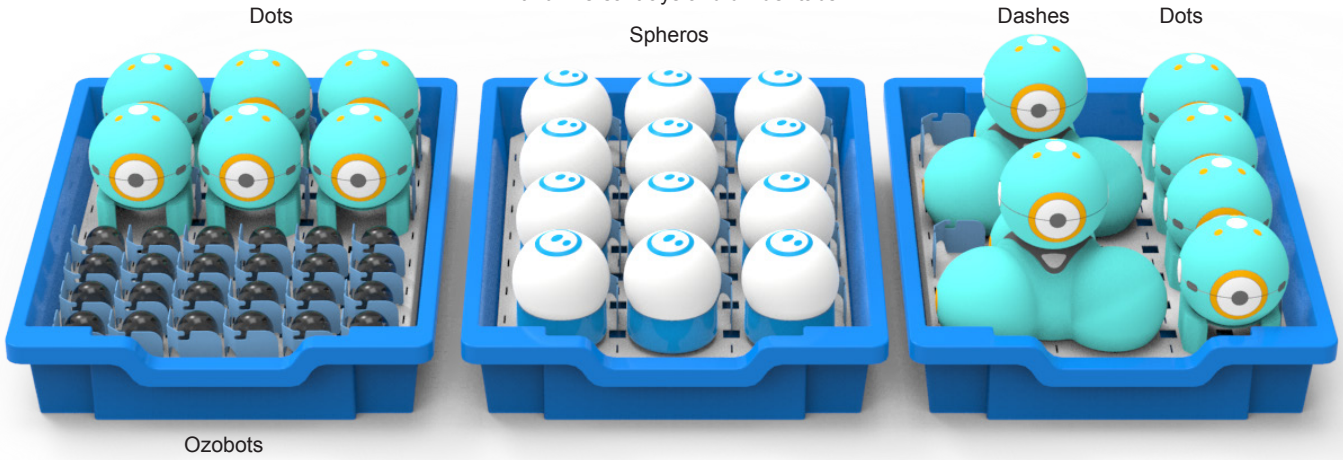
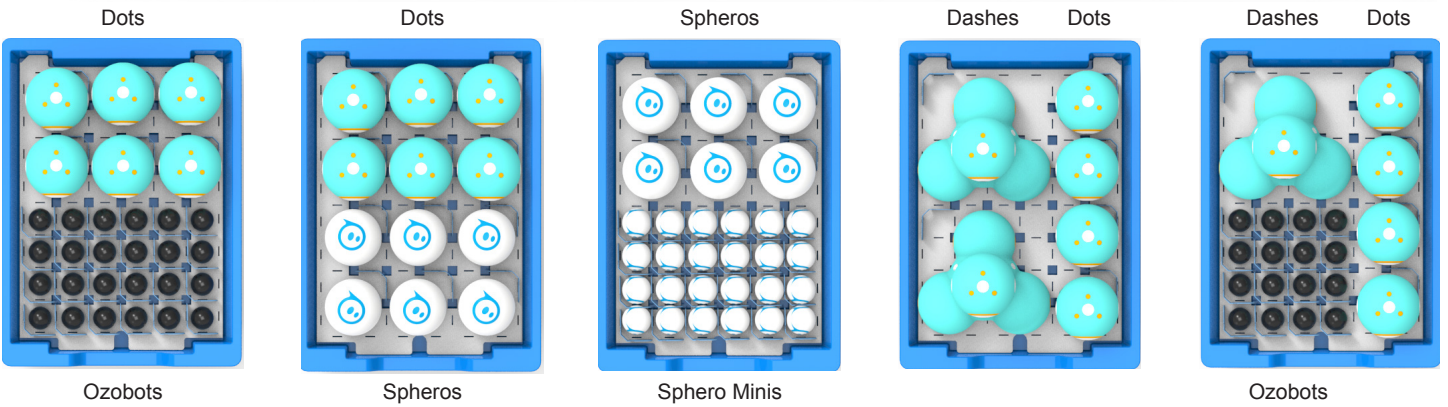

Figure 5.5

Robot combinations
with universal trays and divider tabs



Ozobots



Ozobots

Spheros

Sphero Minis

Ozobots

Cubelets



*Devices not included.

6 USB charging - optional

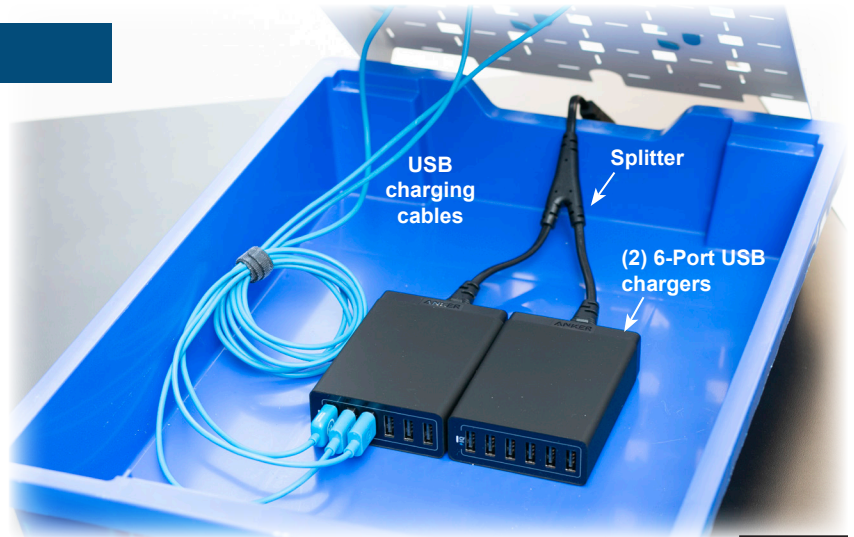
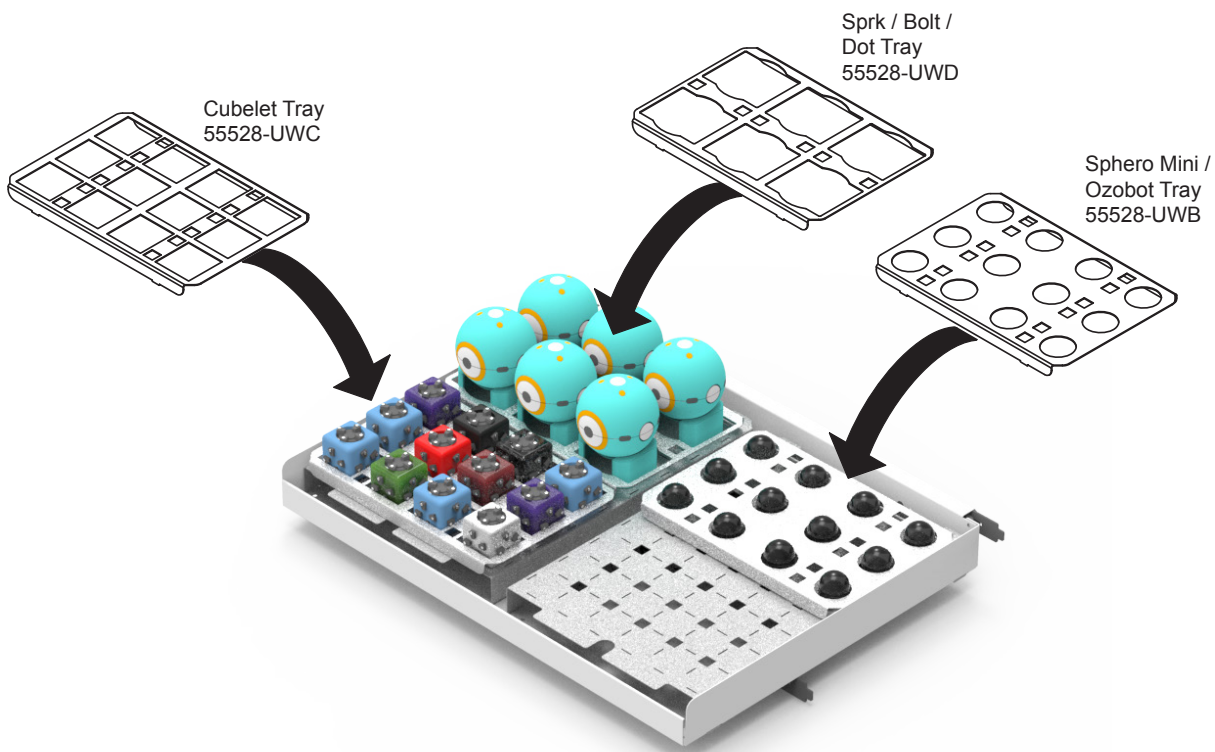
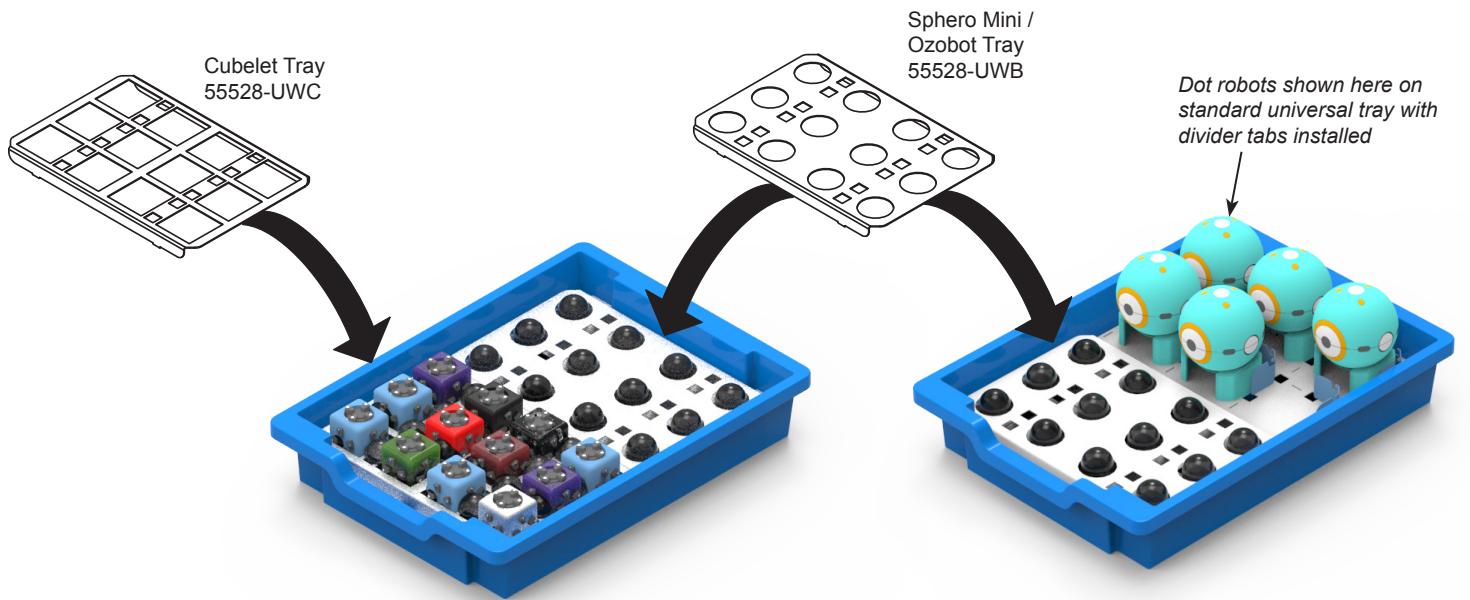
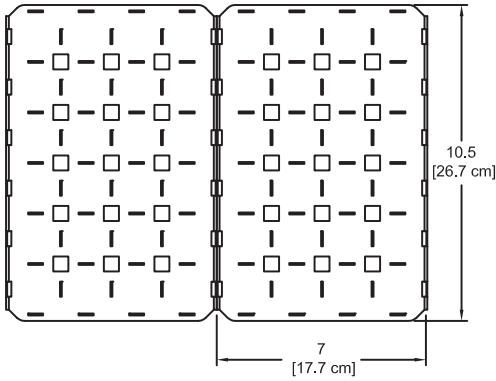

Figure 6

Optional trays
(See p.8)



Accessories



Universal Tray - 55528UWA

- Offers flexibility-accommodates most robots
- Fits in bottom of blue plastic bin or shelf
- (2) trays included
- Divider tabs not included-see 55530 below
- 10.5"W [26.7 cm] x 7"D [17.8 cm] x .65375"H [1.7 cm]
- Unit weight: .5 lb [.227 kg]
- Shipping weight: 1 lb (.454 kg)

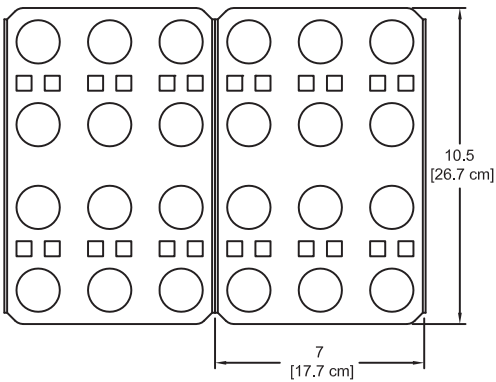
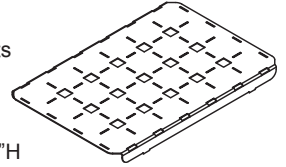

Sphero Mini / Ozobot Tray - 55528UWB

- Holds 24 devices
- (2) trays included
- 10.5"W [26.7 cm] x 7"D [17.8 cm] x .65375"H [1.7 cm]
- Unit weight: .5 lb [.227 kg]
- Shipping weight: 1 lb [.454 kg]

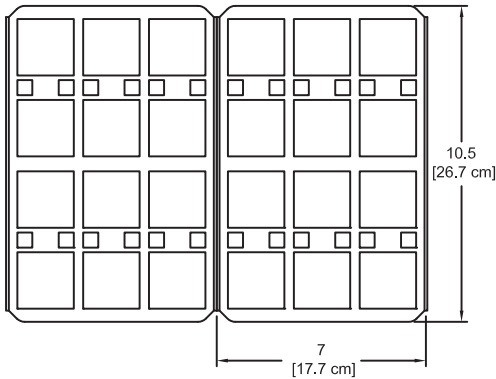
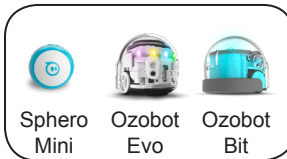
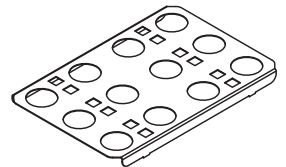

Cubelet Tray - 55528UWC

- Holds 24 devices
- (2) trays included
- 10.5"W [26.7 cm] x 7"D [17.8 cm] x .65375"H [1.7 cm]
- Unit weight: .5 lb [.227 kg]
- Shipping weight: 1 lb (.454 kg)

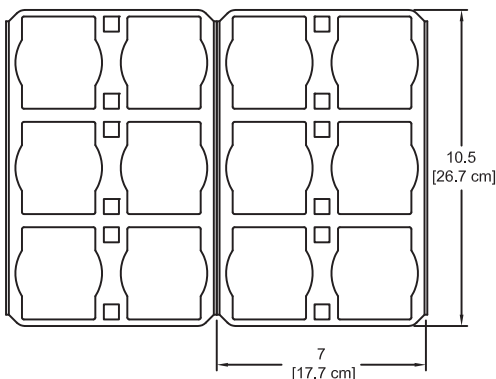
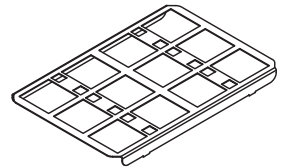

Sprk / Bolt / Dot Tray - 55528UWD

- Holds 12 devices
- (2) trays included
- 10.5"W [26.7 cm] x 7"D [17.8 cm] x .65375"H [1.7 cm]
- Unit weight: .5 lb [.227 kg]
- Shipping weight: 1 lb [.454 kg]

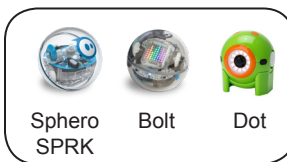
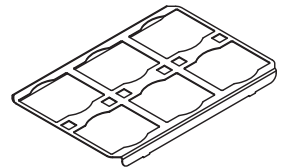

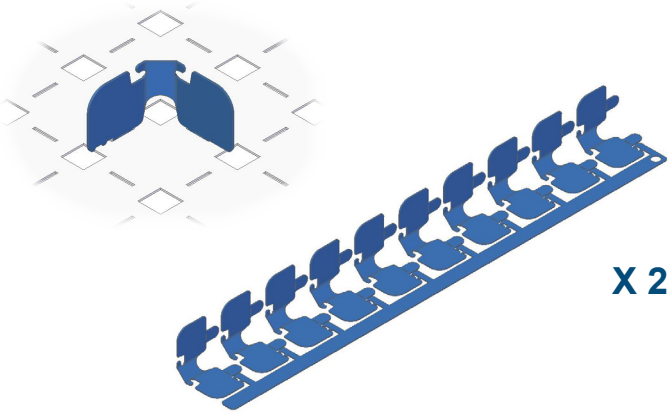

X 2

Divider Tabs - 55530LB

- For use with universal trays only
- Provides semi-permanent areas for robots on the universal tray
- Provides charge cord management
- 20ga steel
- (20) divider tabs included in two bar assemblies
- Light blue powdercoat
- Unit weight: .8 oz [23g]
- Shipping weight: 16 oz [454g]



USB charger 6-port - 55522

- For charging robots
- Mounts under tray or on shelf
- 6 USB ports (up to 2.4A per port)
- 60W, 12A max
- 5' detachable power cord
- UL-certified
- 3.9" [99mm] x 2.8" [70mm] x 1" [26mm]
- Unit weight: 6.7 oz [190g]
- Shipping weight: 16 oz [454g]

For charging only-no data



USB charger 10-port - 55529

- For charging robots
- Mounts under tray or on shelf
- 10 USB ports (up to 2.4A per port)
- 60W, 12A max
- 5' detachable power cord
- 4.4" [112mm] x 2.7" [68mm] x 1.1" [27mm]
- Unit weight: 7.7 oz [218g]
- Shipping weight: 16 oz [454g]

For charging only-no data



Splitter - 55531

- Allows two USB chargers to be powered from a single cord
- (1) C8 male to (2) C7 female
- Length: 12" [30 cm]
- Unit weight: 12.8 oz [362g]
- Shipping weight: 16 oz [454g]

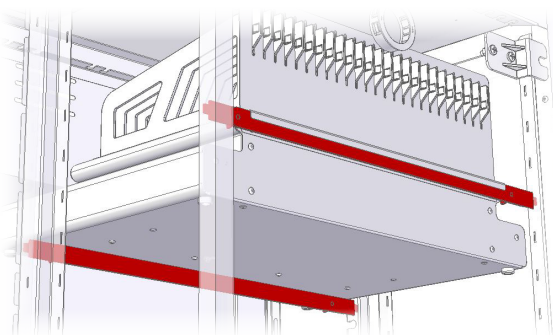

Device Module Bar Kit - 95011

- For mounting modules into select carts
- (2) bar assemblies included
- Shipping weight: 1 lb [.45 kg]

See spectrumfurniture.com for the latest accessories and detailed warranty information.