

Technical Specifications

55355	Freedom One Lectern (Includes lectern, equipment rack, and unit-to-unit connector kit)
-------	----------------------------------------------------------------------------------------------

55366	Equipment rack only
55367	Unit-to-unit connector kit
55368	Freedom One Lectern only

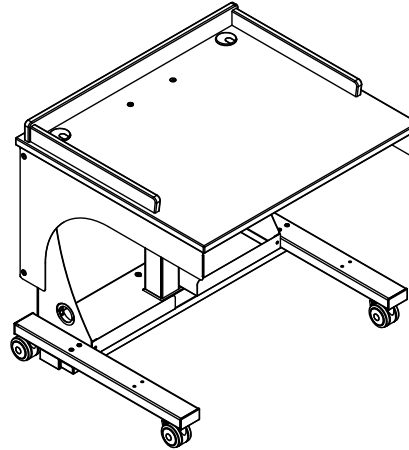
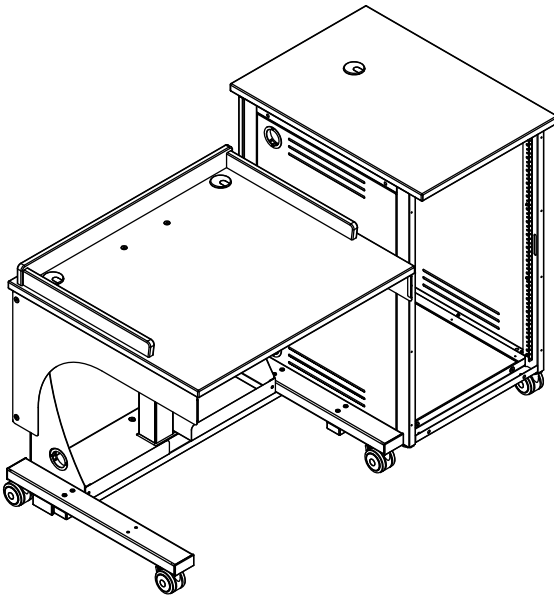

Use the Freedom One Sit-to-Stand Lectern where worksurface height adjustment or ADA compliance is required and rack rail for equipment storage is required. The lectern can have either glides or casters installed for stationary or mobile use. Manually adjust the worksurface height from 30-42" (with casters) with a pneumatic-gas assisted spring. The worksurface has a lift capacity of 38 pounds. The lectern worksurface is 34" wide and 30" deep with two cable holes with grommets and a surround. An optional logo plate can be added to the audience side of the lectern for institution branding. The Equipment Rack can be mounted on the left or the right. The worksurface is 21" wide and 30" deep. The worksurface has a cutout with included cover. An optional power module can be added to this cutout. The Equipment rack has 36 rack units with 18 rack units accessible from the audience side and the presenter sides. The audience side has a locking door, and an optional locking door can be added to the presenter side. Other options can be added including rack-mount accessories (shelves, drawers, cooling fans, and others).

Base Options	
TW - 3" Twin-Wheel casters	(Both options are included)
G - Bell glides	

Color Options

Standard laminate / color combinations

Wild Cherry / Black (CHB)	
Indigo Organix / Black (IB)	
Fusion Maple / Black (FMB)	
Indigo Organix / Silver Sparkle (IS)	
Fusion Maple / Silver Sparkle (FMS)	

Standard color combination refers to the quickest deliverable product color combination. Custom laminates and color combinations are available-additional lead-times and up-charges may apply. Call 1-800-235-1262 for further information.

Features and Benefits

- Adjustable-height workstation easily adjusts between varying seated or standing-use heights
- Smooth, easy lift mechanism with pneumatic spring and mechanical release
- Lightweight with a small overall footprint
- ADA-compliant
- Lectern / equipment rack can be assembled in a left or right-hand configuration
- Lectern available as a stand alone unit
- Surround on movable worksurface provides privacy and styling
- Equipment rack with rack-rail mounting 36RU (18RU front and 18RU rear) simplifies installation for any equipment configuration with enough space for an internal CPU
- Side equipment rack grommet holes and worksurface grommets provide superior cord access (covers included)
- Keyed locking audience-side (and optional front) door provides security and easy-access
- 3" swivel locking Twin-Wheel casters, and stationary bell glides are included (user choice)
- Ventilated equipment rack side panels keep equipment cool
- Scratch and impact-resistant high-pressure laminate tops provide durable, useful worksurfaces for instructors
- Cable grommets throughout unit and cord channel provide easy cord routing
- One 2" grommet in bottom of equipment rack provides cord access below unit
- Two 2" cable grommets (left and right) on the adjustable worksurface provide cable access (covers included)
- Optional solid or acrylic door provides security and access to internal equipment
- Customizable modesty / logo panel (must be specified when ordering)
- Durable powder coated steel chassis provides a long-lasting finish
- SCS Indoor Advantage Certified; meets or exceeds applicable ANSI-BIFMA test standards
- Warranted to be free of all defects in materials and workmanship for 10 years
- Assembled in Chippewa Falls, WI, USA

Construction

- The worksurfaces are constructed from 1" thick NAUF (No Added Urea Formaldehyde) composite board with .030" high-pressure laminate on one face, and a balancing phenolic backer on the opposing face
- Metal components consist of 16-gauge and 20-gauge steel
- Worksurface edges are covered with 3mm vinyl
- All metal components are finished with a scratch-resistant powder coat epoxy
- Each Freedom One Lectern and equipment rack ships assembled. Customer assembles casters or glides and attaches equipment rack to lectern if required.

Specifications

Adjustable worksurface height	30"H [76.2 cm] - 42"H [106.7 cm] (with casters) 29.25"H [74.3 cm] - 41.25"H [104.8 cm] (with glides)	
Lectern	0-18 lb [8.2 kg] - Factory-set (normal operation) 18 lb [8.2 kg] - 38 lb [96.5 kg] (max) - Additional force needed to raise worksurface	
Equipment rack	Rack rail: 36RU (18RU front and 18RU rear) Note: <u>One</u> equipment rack can be attached to the lectern on the left <u>or</u> right side. Any additional racks have to be free-standing.	
ADA-compliance*	knee clearances: 33.5"W [85 cm] x 22.375"D [56.8 cm] x 29"H [73.7 cm] (1 person per lectern) <i>*Minimum ADA guidelines for knee clearances are 30"W x 19"D x 27"H</i>	
3" Twin Wheel casters	Weight capacity 165 lb [75 kg] each (6 included)	
Worksurface grommet	7.25"W [18.4 cm] x 3.875"D [9.8 cm]	
Optional keyboard tray	21.375"W [54.3 cm] x 15.1875"D [38.6 cm] x 2.1875"H [5.6 cm] (available height to worksurface) <i>worksurface needs to be raised 3.375" for ADA-compliant knee clearance</i>	
Unit weight (nominal)	189 lb [85.8 kg] N/A N/A N/A	55355 - Freedom One Lectern (all 3 components) 55366 - Eq rack only 55367 - Unit-to-unit kit only 55368 - Freedom One Lectern only
Shipping weight (nominal)	272.5 lb [123.7 kg] 94 lb [42.7 kg] 5 lb [2.3 kg] 178 lb [80.8 kg]	55355 - Freedom One Lectern (all 3 components) 55366 - Eq rack only 55367 - Unit-to-unit kit only 55368 - Freedom One Lectern only

Specifications subject to change without notice

Adjustable worksurface includes two 2" grommet holes for routing cords from worksurface (covers included)

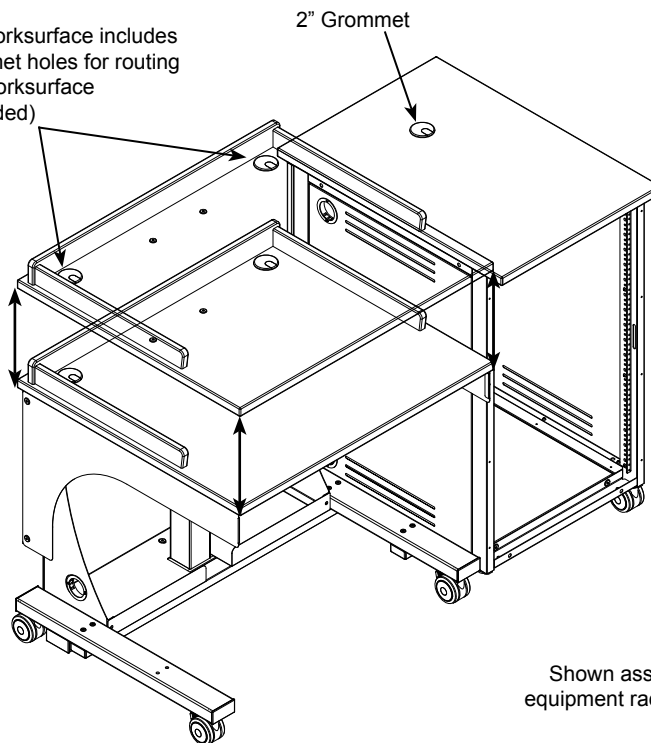

Shown assembled with equipment rack on right side

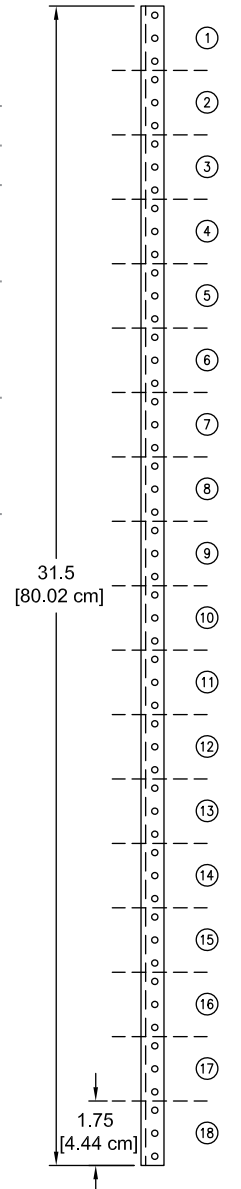

36RU available (18RU front and 18RU rear)

**Freedom One Lectern
with equipment rack
55355**

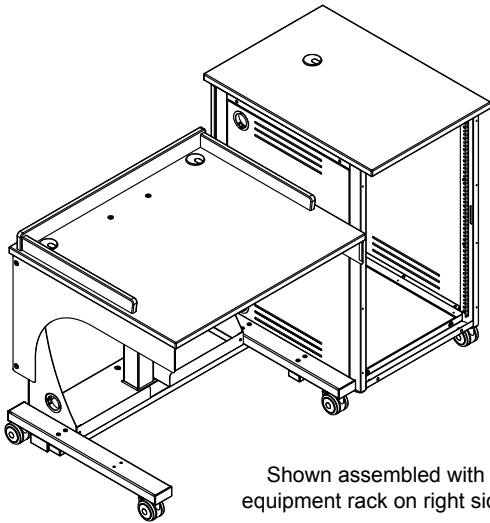

Shown assembled with
equipment rack on right side

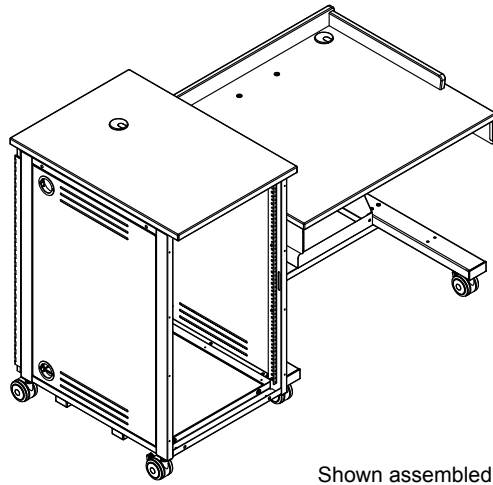

Shown assembled with
equipment rack on left side

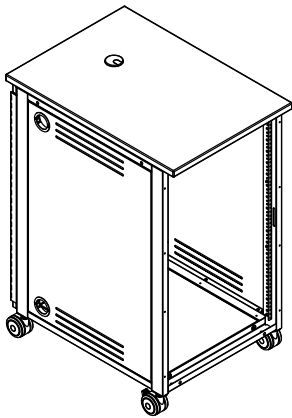

**Equipment rack
55366**

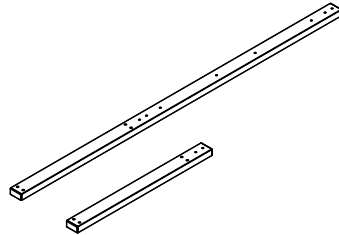

**Unit-to-unit connector kit
55367**

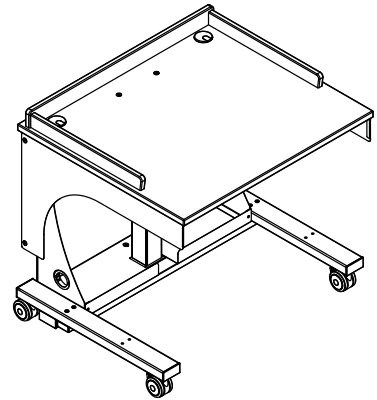

**Freedom One Lectern
55368**

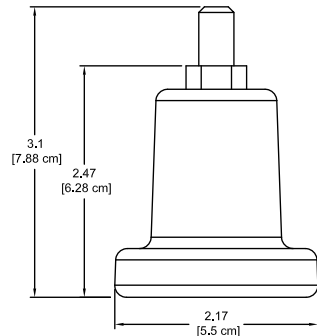
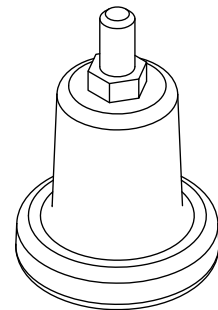
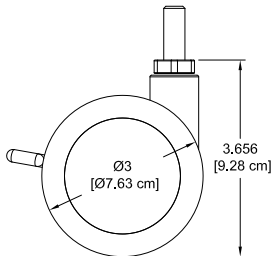
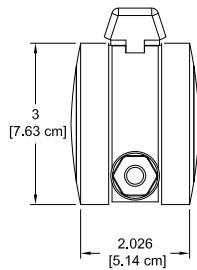
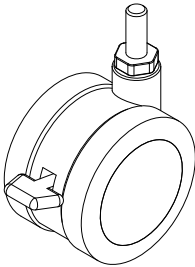

Note: Casters are made of
"soft thermoplastic".

**3" Twin-Wheel caster
(TW)**

3" Bell Glide (G)

Freedom One Lectern
 (Right-assembled with TW casters)

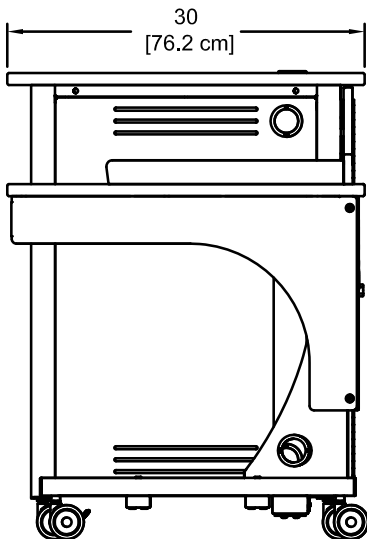
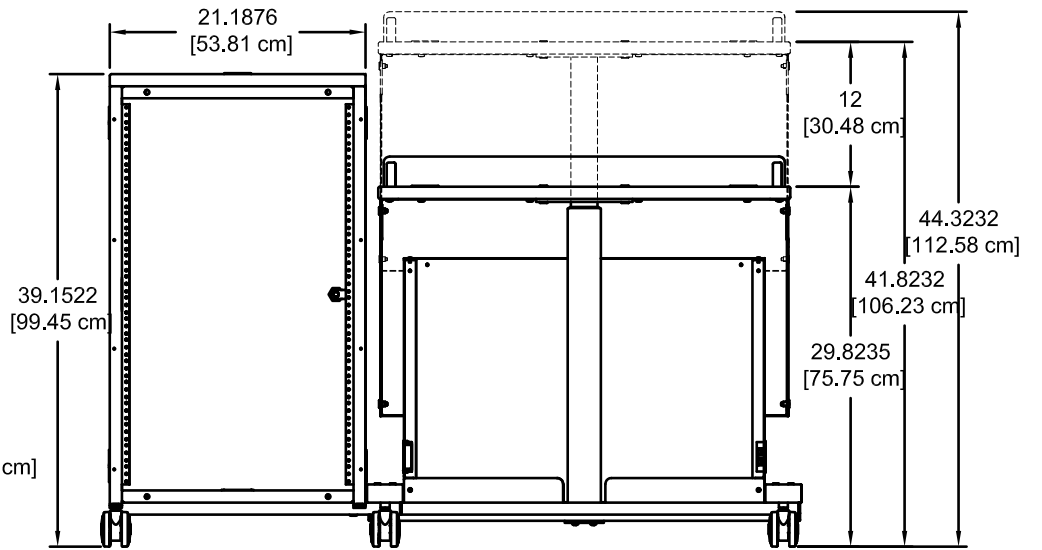
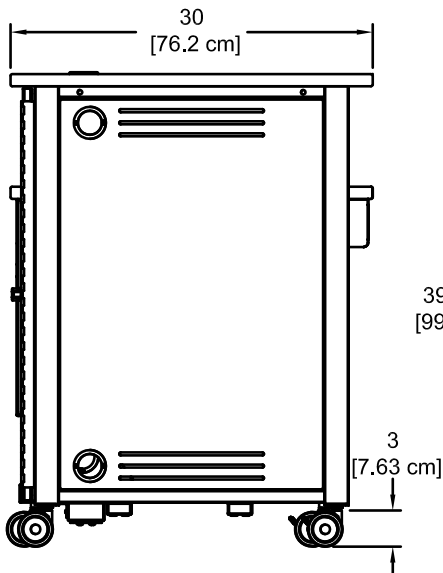
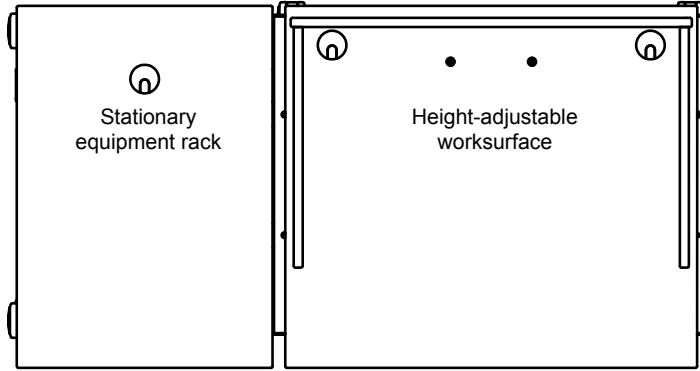

Adjustable worksurface side view

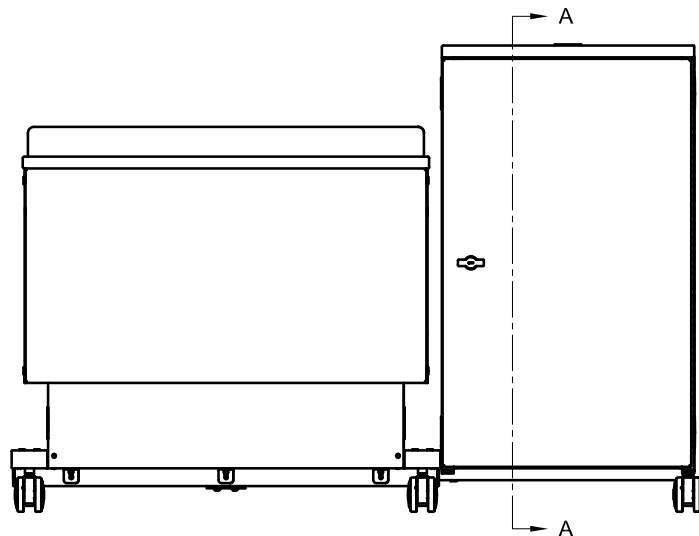

Audience side view

Equipment rack
Section view A-A

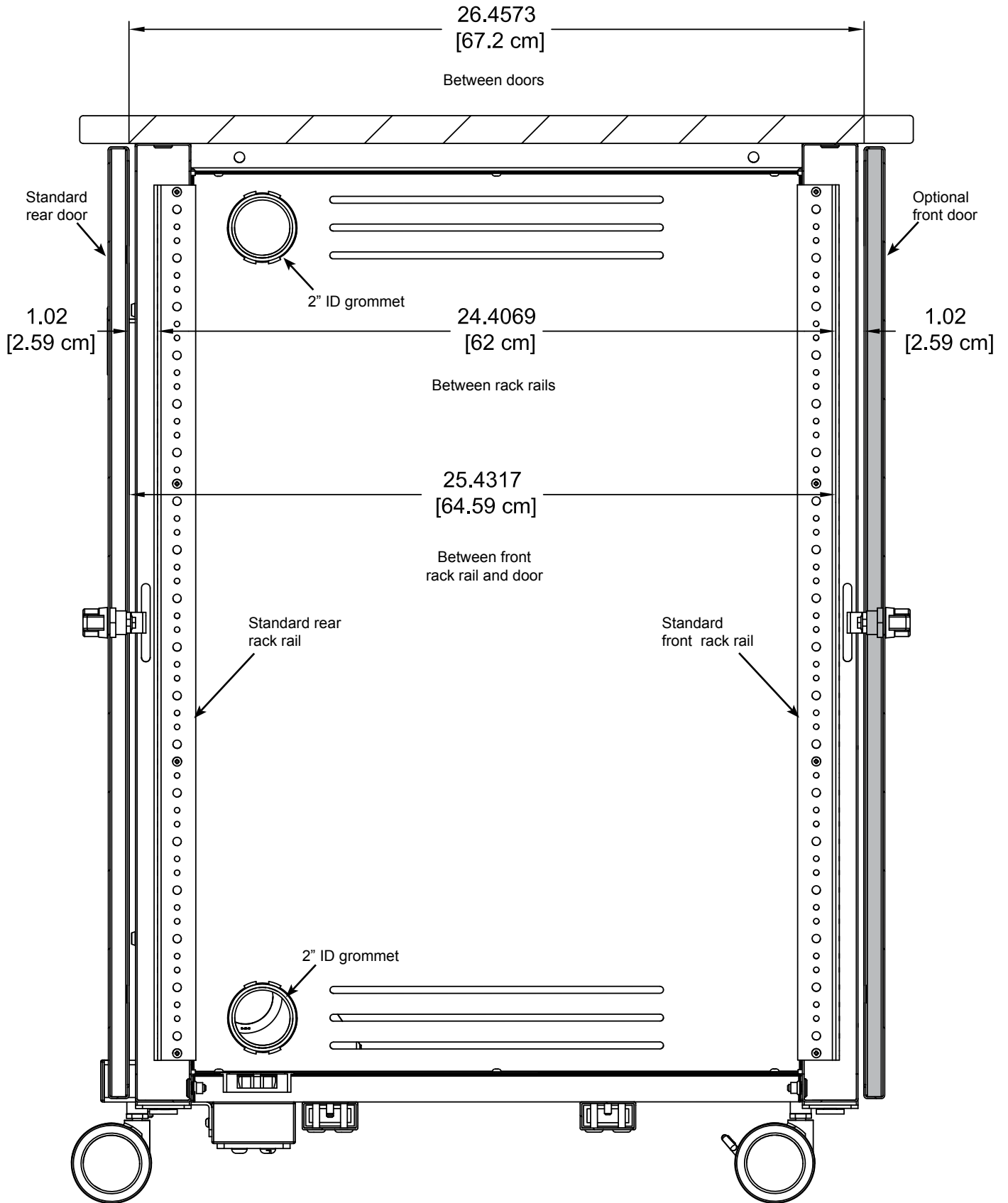

Note: Modified worksurface cutouts should be reviewed by Spectrum to ensure clearance of brackets, keyboard slides, or other objects under the worksurface. The weight of installed components should also be considered.

Available cutout areas
(no keyboard tray)

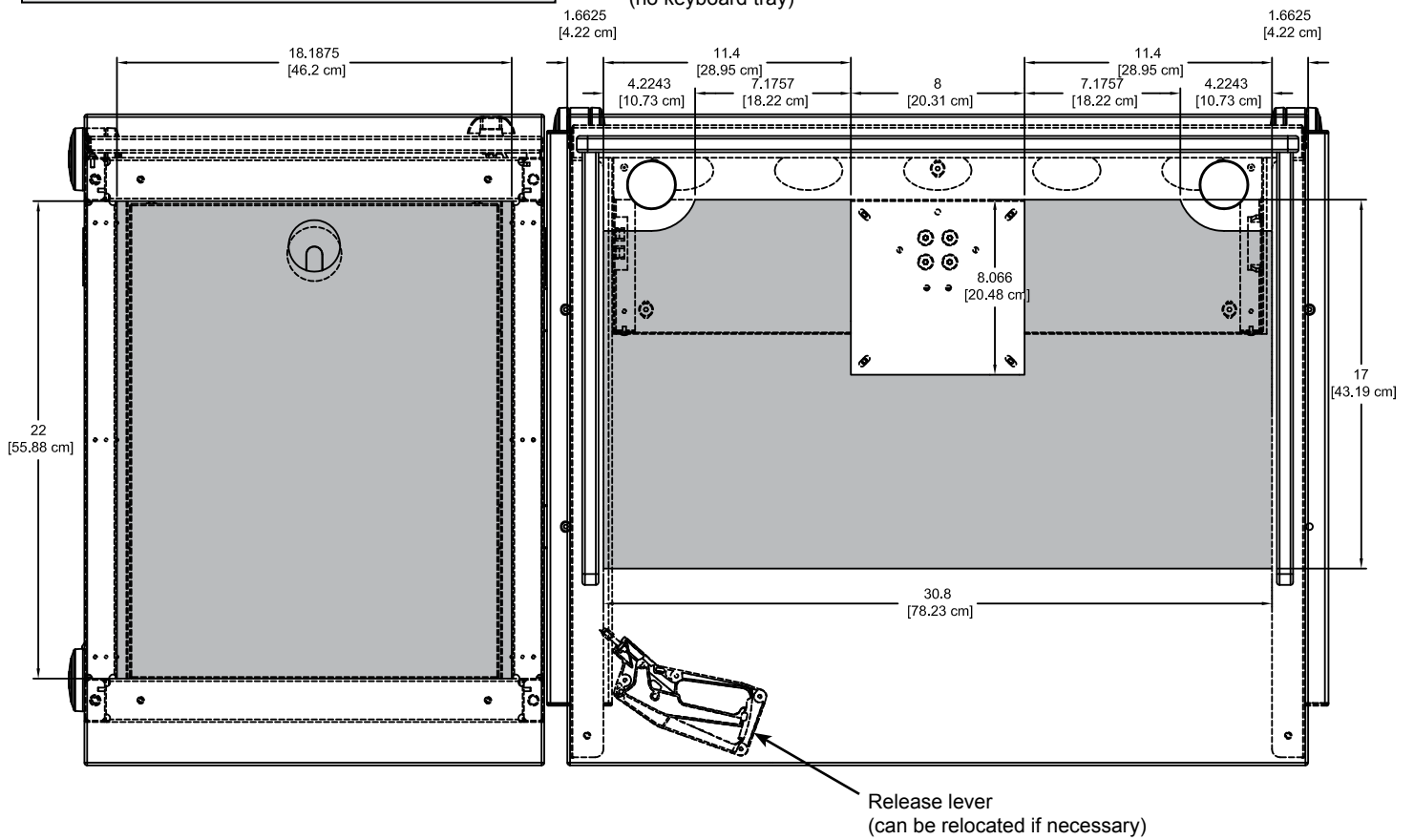

Available cutout areas
(with keyboard tray)

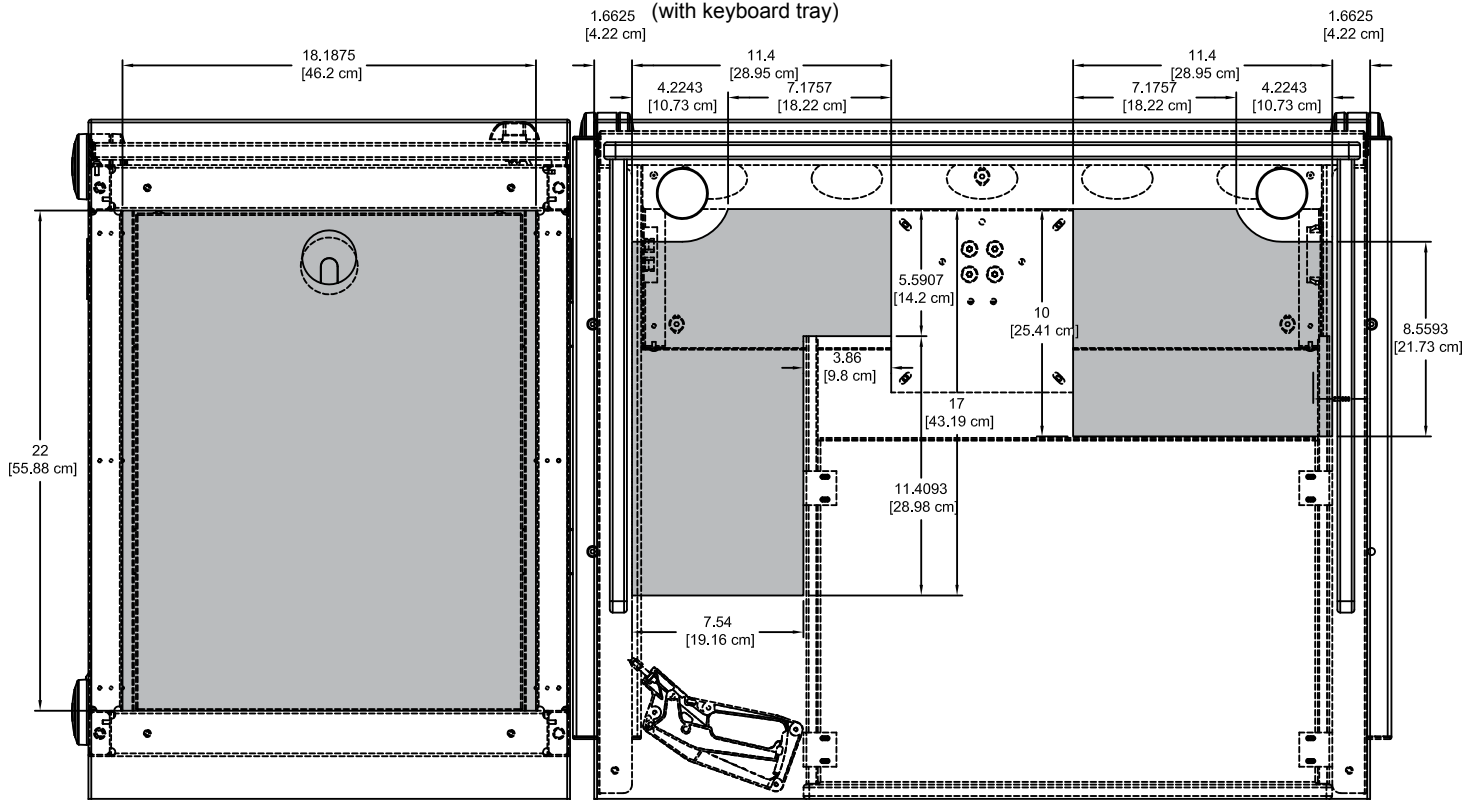

Accessories

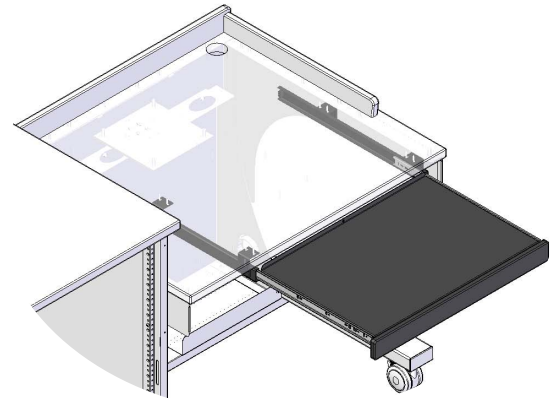
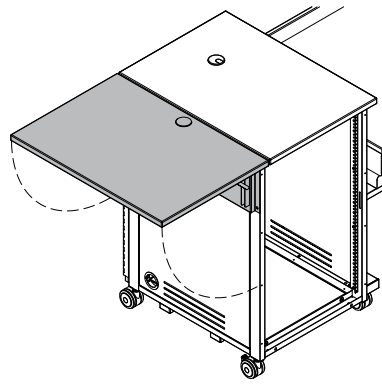
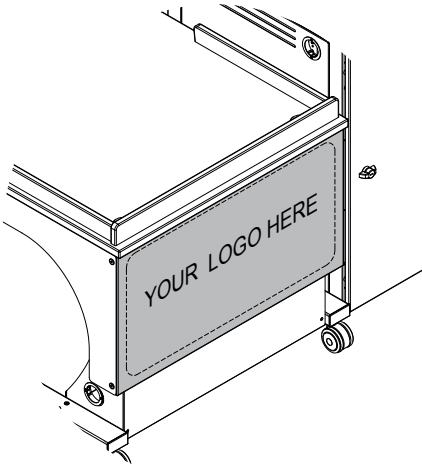

Note: Not recommended for use on stand-alone equipment racks.

Customized modesty panel with logo for Freedom One Lectern

- To get a customized logo panel, contact Spectrum to specify all logo details
- New logos require a first time logo charge

Flip-up Shelf - 68204

- Shelf hinges lock into place in the upright position
- Includes 2" grommet
- Mounts on left or right
- Available in matching, or White Chalk Dry Erase laminate
- Mounting plate available in black or dark gray

Dimensions: 21.1875"W [53.8 cm] x 30"D [76.2 cm] x 1"H [2.54 cm]
 Weight capacity: 50 lb [22.7 kg]
 Shipping weight: 15 lb [6.8 kg]

Keyboard Tray - 55356

22"W [55.9 cm] x 15.1875"D [38.6 cm] x 1.1875"H [3 cm]

Note: Worksurface has predrilled holes to simplify mounting. See capacity section for worksurface weight info. (38 lb max weight on adjustable worksurface)

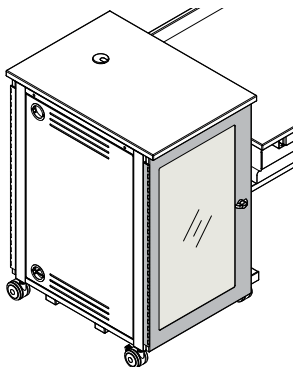

Clear Acrylic Locking Door 68153B 68153S

- Can be mounted to be hinged from the left or right side
- Available in black or silver sparkle

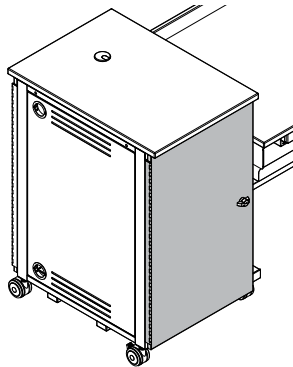

Solid Locking Door 68152B 68152S

- Can be mounted to be hinged from the left or right side
- Available in black or silver sparkle

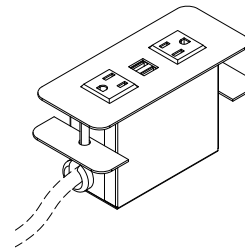

Cove Power Module - 99044



- Two power receptacles per module
- Two USB charge ports (not data-compatible)
- Thumbscrew clamps
- Requires worksurface cutout
- ETL listed
- Available in Black or Silver

Cutout required: 5.25"W [13.3 cm] x 2"D [5.1 cm] (mounts to surface thicknesses up to 1.5")

Power cord: 9' [274 cm] with 90° flat plug with 45° rotation

Power receptacles: 12A, 120 VAC spill-resistant
 USB charging ports: 2.1A (10.5W)

Dimensions: 6"W [15.2 cm] x 2.5"D [6.35 cm] x 3.18"H [8.1 cm]

Unit weight: 2.29 lb [1 kg]

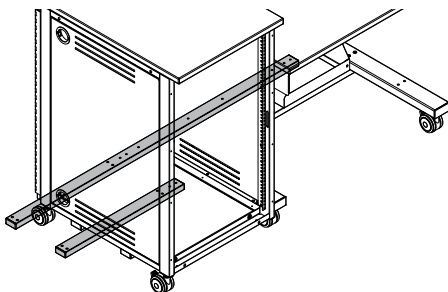

Unit-to-unit connector kit - 55367

for connecting equipment rack to lectern (available in black or silver sparkle)

8/29/17



See spectrumfurniture.com for the latest available flat panel monitor arms, and rack-mount accessories.

Warranty

WE WILL MAKE IT RIGHT FOR YOU!

Spectrum is committed to provide complete customer satisfaction. Each of our products is manufactured from the best materials available and each product is stringently monitored throughout the production process through our P.A.C.E. program (Product Assurance to meet Customer Expectations).

We expressly warrant that Spectrum products will be of good quality and workmanship and free from defect for the period set out in the warranty table below from the date of delivery. This warranty shall not apply to defects or damage resulting from misuse, abuse, neglect, improper care, modification or repair not authorized by Spectrum, or any other cause outside the control of Spectrum. Spectrum will, at its sole option, either repair or replace the defective product.

This warranty is exclusive; no other warranty, written or oral, is expressed or implied. This warranty is given by Spectrum to Buyer and to no other person or legal entity. No Spectrum dealer, distributor, agent or employee is authorized to make any modification or addition to this warranty.

NOTWITHSTANDING ANYTHING TO THE CONTRARY, SPECTRUM WILL NOT UNDER ANY CIRCUMSTANCES BE LIABLE FOR INDIRECT OR LIQUIDATED DAMAGES, INCLUDING CONSEQUENTIAL, INCIDENTAL AND SPECIAL DAMAGES. IN NO EVENT SHALL SPECTRUM'S LIABILITY, WHETHER UNDER CONTRACT OR WARRANTY, IN TORT OR OTHERWISE, EXCEED THE PURCHASE PRICE RECEIVED BY SPECTRUM FOR THE PRODUCT AT ISSUE AND "RECALL ACTION" EXPENSES. SPECTRUM SHALL NOT BE SUBJECT TO ANY OTHER OBLIGATIONS OR LIABILITIES, WHETHER ARISING OUT OF BREACH OF CONTRACT, WARRANTY, TORT (INCLUDING NEGLIGENCE AND STRICT LIABILITY) OR OTHER THEORIES OF LAW, WITH RESPECT TO PRODUCTS SOLD OR SERVICES RENDERED BY SPECTRUM, OR ANY UNDERTAKINGS, ACTS OR OMISSIONS RELATING THERETO.

Our Customer Service Department is ready to provide immediate attention to any questions, comments or concerns. They are available to answer your calls Monday through Friday from 7 am to 5 pm CST. In addition your product comments or concerns are welcome via e-mail at: spectrum@spectrumfurniture.com.

Warranty Table

Item	Warranty Period effective 1/1/2015
Adjustable Crank / Electric Desk Legs	• 1 Year
Flat Panel Desk Gas Cylinders	
Chairs <ul style="list-style-type: none"> • Adjustable Height Chair Parts – including frames, gas cylinders, wood and plastic parts, control handles, casters • Adjustable Height Chair Upholstery • In-Stock Upholstery • Graded-In Fabrics and Customer Owned Material 	<ul style="list-style-type: none"> • 7 Years • 2 Years • 2 Years • No Warranty
Height Adjustable Columns and Lifts	• 1 Year
General Use Casters	
Electrical (including timers and LINAK actuators)	• 2 Years
Keyboard / Mouse Trays	• 1 Year
Flat Panel Monitor Arms <ul style="list-style-type: none"> • Flat Panel Monitor Arm – General Parts • Flat Panel Monitor Arm – Gas Cylinders 	<ul style="list-style-type: none"> • 5 Years • 2 Years
Desks and Lecterns <ul style="list-style-type: none"> • Computer Desk Chassis • Cart Chassis • Lectern Chassis 	• 10 Years

